

Dimensions (Unit: mm)

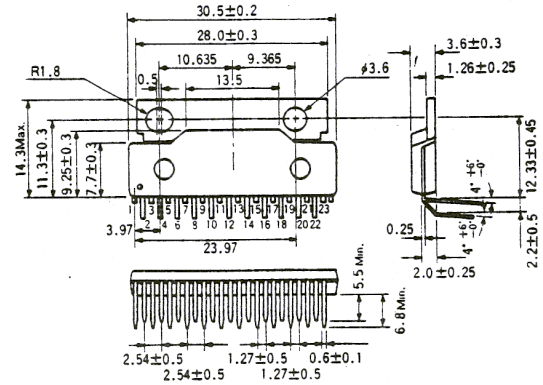

Fig. 1

The BA6200AL is a monolithic, 3-phase DD motor driver designed for use in VCRs (for drum and capstan motor driving), tape decks, record players, floppy disk drives, and so forth. The device chip contains a Hall amplifier, control logic, power driver, neutral voltage feedback amplifier, braking logic, FG amplifier, and thermal shut-down (T.S.D.) circuit.

Features

1. Integrates on a single chip all functions required for 3-phase DD motor driving.
2. Driving current feedback circuit assures smooth, stable motor driving.
3. Complete internal protection which prevents the upper and lower transistors from being simultaneously turned on when the direction of rotation is being reversed.
4. Powerful, coil-shunt type, forced stop feature incorporated on the chip.
5. Internal device protection including thermal shut-down circuit (T.S.D.).
6. Separate power supplies with wide voltage ranges can be used for the control logic (5 to 13 V) and output stage (4 to 26 V).
7. The maximum output current is 1.5 A.
8. Available in a 23-pin LF package for compact system design.
9. Pin configuration facilitates easy foil pattern design.

Applications

VCR drum motor driver
 VCR capstan motor driver
 DD motor driver for tape decks, record players, etc. Floppy disk drives

Block Diagram

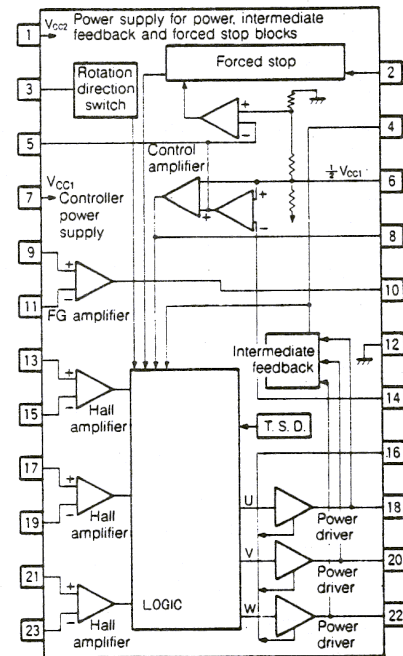

Fig. 2

Absolute Maximum Ratings (Ta=25°C)

Parameter	Symbol	Limits	Unit
Supply voltage	V _{CC1} /V _{CC2}	13/26	V
Power dissipation	P _d	2.75	W
Operating temperature range	T _{opr}	-20 ~ 75	°C
Storage temperature range	T _{stg}	-55 ~ 125	°C
Output current	I _o	1.5	A
Hall amplifier input voltage	V _H	0 ~ V _{CC1}	V
Rotation direction switching voltage	V _{FIR}	0 ~ V _{CC1}	V
FG amplifier output voltage	V _{FGO}	6	V

Electrical Characteristics (Unless otherwise specified, Ta=25°C, V_{CC1}=5V, V_{CC2}=15V)

Parameter	Symbol	Min.	Typ.	Max.	Unit	Conditions	Test circuit
Control circuit quiescent current	I _{o1}	6.00	9.58	14.00	mA	V _{CTL} =1/2V _{CC1} , V _{FIR} =0V	Fig. 3
Power block circuit quiescent current	I _{o2}	3.13	4.70	7.24	mA	V _{CTL} =1/2V _{CC1}	Fig. 3

< Hall Amplifier Block >

Parameter	Symbol	Min.	Typ.	Max.	Unit	Conditions	Test circuit
Input bias current	I _{BH}	—	1.25	10	μA	V _H =1/2V _{CC1}	Fig. 3
Common-mode input voltage range	V _H	1.5	—	3.5	V	—	Fig. 3
Input offset		—	—	±10	mV	—	Fig. 3

< Output Amplifier Block >

Parameter	Symbol	Min.	Typ.	Max.	Unit	Conditions	Test circuit
Saturation voltage 1	V _{sat1}	—	0.8	1.5	V	I _{OUT} =1A(lower side of power transistor)	Fig. 3
Saturation voltage 2	V _{sat2}	—	1.15	1.85	V	I _{OUT} =1.5A(lower side of power transistor)	Fig. 3
Saturation voltage 3	V _{sat3}	—	1.65	2.35	V	I _{OUT} =1A(upper side of power transistor)	Fig. 3
Saturation voltage 4	V _{sat4}	—	2.25	2.95	V	I _{OUT} =1.5A(upper side of power transistor)	Fig. 3

< Control Amplifier Block >

Parameter	Symbol	Min.	Typ.	Max.	Unit	Conditions	Test circuit
1/2V _{CC1} reference voltage	V _{CC1} /2	2.25	2.50	2.75	V	—	Fig. 3
Threshold voltage	V _{TH}	0.06	0.12	0.18	V	I _{OUT} =20mA	Fig. 3

< Rotation Direction Switching Block >

Parameter	Symbol	Min.	Typ.	Max.	Unit	Conditions	Test circuit
Forward mode voltage range	V _F	0	—	2.3	V	—	Fig. 3
Reverse mode voltage range	V _R	4.2	—	12	V	—	Fig. 3
Output off mode voltage	ΔV _{off}	40	320	—	mV	—	Fig. 3

< Intermediate Feedback Block >

Parameter	Symbol	Min.	Typ.	Max.	Unit	Conditions	Test circuit
Intermediate potential	V _O	6.5	7.15	7.8	V	—	Fig. 3

< FG Amplifier Block >

Parameter	Symbol	Min.	Typ.	Max.	Unit	Conditions	Test circuit
Open loop gain	G _{FG}	—	66	—	dB	V _{OUT} =0.5V	Fig. 3
Rolloff frequency	f _{FG}	10	20	40	kHz	ΔG _V =3dB	Fig. 3
Total harmonic distortion	THD	—	—	5	%	V _{OUT} =0.5V, f=1kHz	Fig. 3

Test Circuit

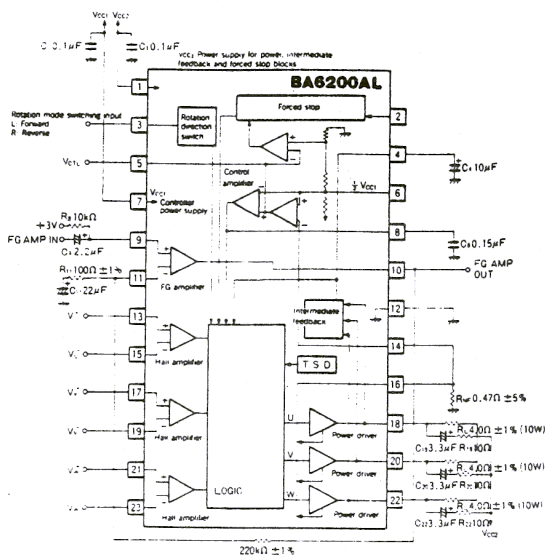

Fig. 3

Application Example

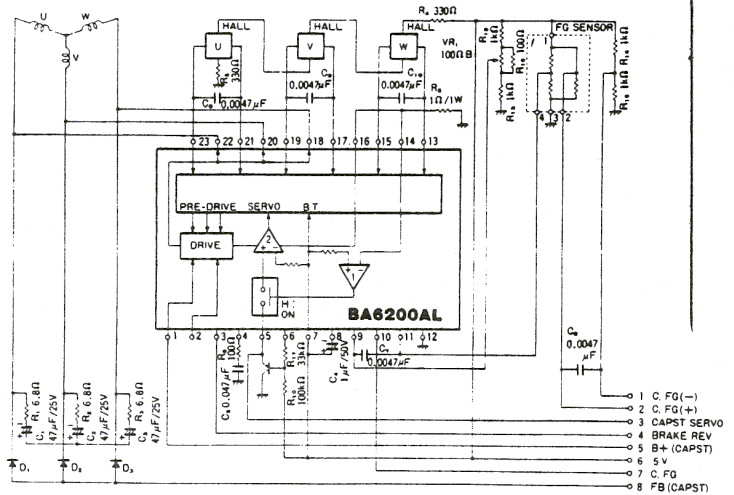

Fig. 4

Circuit Description

1. Reversing logic

The reversing logic uses a 3-level logic switch. The voltage ranges corresponding to the three switch levels are shown in Fig. 7.

2. Hall amplifiers, logic block, and power drivers

Pins 13, 15, 17, 19, 21, and 23 are Hall amplifier inputs that accept Hall device turn-on signals. The Hall amplifiers amplify the small Hall device output levels (30 to 200 mV p-p) to a level sufficient to obtain rotor position information by a zero-cross circuit within the logic block. The logic block converts Hall device turn-on position signals into logic signals and transfers them to the power drivers.

The power drivers supply driving currents (which correspond to the logic signals) to the motor windings to drive the motor.

3. Intermediate feedback block

The intermediate feedback block sets the output reference so that the winding driving signals (at pins 18, 20, 22) oscillate with equal peak levels on either side of the level 1/2

V_{CC2} . The output waveform becomes (B) or (C) in Fig. 5 if pin 4 is pulled up to V_{CC2} or down to GND.

4. Thermal shut-down (T.S.D.) circuit

If the chip temperature is raised to an abnormally high level due to an output short-circuit accident or a disturbed Hall signal input, the T.S.D. circuit is activated to shut down the device's driving outputs.

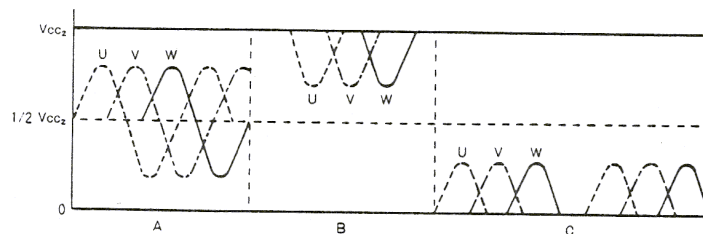

Fig. 5

Pin Description

1. Input pins (pins 13, 15, 17, 19, 21, and 23)

These pins receive Hall device output signals. The recommended signal level is 100 to 300 mV p-p oscillating about 1/2 V_{CC1} .

For the Hall device output U, apply H_u to pin 13 and $H_{\bar{u}}$ to pin 15; for output V, apply H_v to pin 17 and $H_{\bar{v}}$ to pin 19; for output W, apply H_w to pin 21 and $H_{\bar{w}}$ to pin 23.

2. Output pins (pins 18, 20, and 22)

These pins connect to motor windings. Pin 18 supplies the U-phase output; pin 20 supplies the V-phase output; and pin 22 supplies the W-phase output. They are connected to V_{CC2} (pin 1) via a series RC network each to reduce output switching

noise. The recommended circuit constants for this network are $R=10$ to 20Ω and $C=3.3$ to $4.7 \mu F$. The optimum RC time constant depends on the inductance of the load coil windings, and should be selected by the user.

3. Speed control pin (pin 5)

1) When pin 2 is at V_{CC2} :
When the voltage applied to pin 5 is less than 1/2 V_{CC1} , the motor is in a free-run state (stationary). The motor starts rotation at a voltage slightly exceeding 1/2 V_{CC1} , and produces the maximum torque at V_{CC1} .

2) When pin 2 is open:
The motor starts rotation at voltage exceeding 1/2 V_{CC1} , but is braked

at around 1/4 V_{CC1} .

4. Forward/reverse control pin (pin 3)

The voltage applied to pin 3 should be between 0 and V_{CC1} . We recommend that you choose a forward-driving voltage range of 0 to 1.5 V, and a reverse-driving voltage range of 3.5 to V_{CC1} . There is a muted voltage range (in which the motor is in free-run state) between the forward and reverse voltage ranges (see Fig. 6).

5. Braking pin (pin 2)

The motor is braked when pin 2 is at $(V_{CC2} - 3 V)$ or less, and the brake is released when it is at V_{CC2} .

Electrical Characteristic Curves

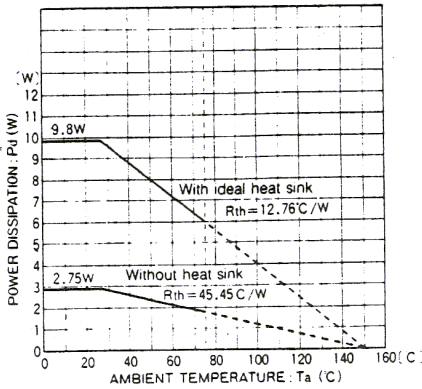

Fig. 6 Derating curves

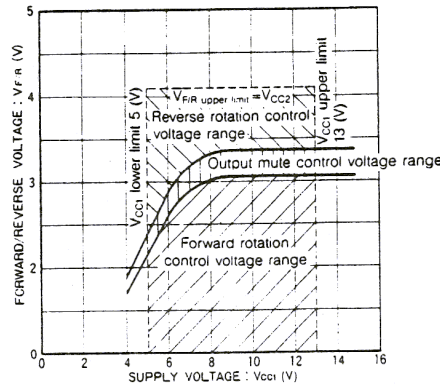

Fig. 7 Rotation switching voltage vs. control block supply voltage

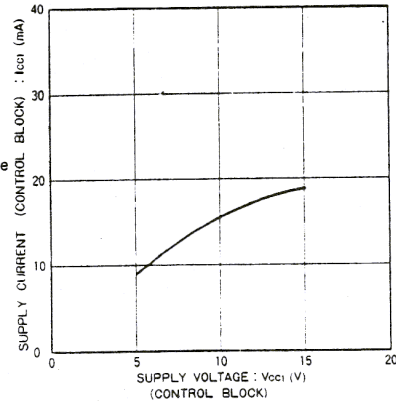

Fig. 8 Control block input current vs. supply voltage

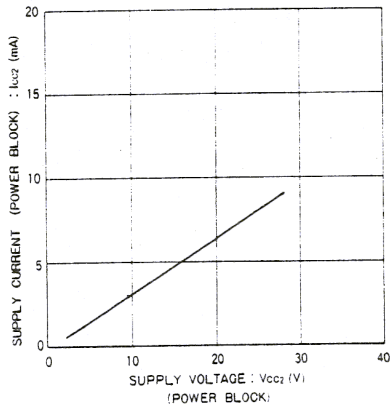

Fig. 9 Power block input current vs. supply voltage

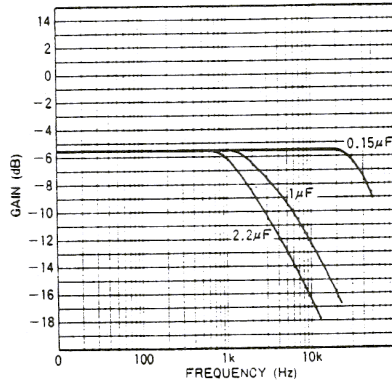

Fig. 10 Frequency response between pins 5 and 16 when varying the value of C₈ (C of pin 8)

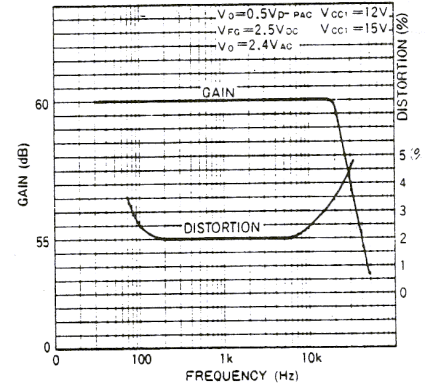

Fig. 11 FG AMP FG/FD characteristics

Precautions

- Although the device contains internal protection such as the T.S.D., it may be damaged in the following cases:
 - If the device is energized without adequate Hall voltages applied to the Hall inputs of the device.
 - If the device is energized with its outputs left shorted.
 - If the device is used while exceeding its absolute maximum ratings, including the cases 1) and 2) above.
- If the Hall device's phase angle or coil position is not adequate, a dead point may occur.