

SDA SERIES SOLID STATE RELAY

**SDA-400D025I-1R
SDA-400D040I-1R
SDA-400D050I-1R
SDA-400D075I-1R
SDA-400D090I-1R
SDA-400D100I-1R**

DC Control AC Loading S.S.R

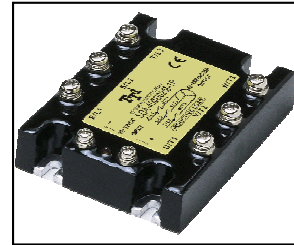

Specifications

MODEL SERIES NO.	CONTROL VOLTAGE	MUST TURN OFF VOLTAGE	INPUT IMPEDANCE	LOADING CURRENT	LOADING VOLTAGE	MIN BLOCKING VOLTAGE	MAX OFF-STATE LEAKAGE	FREQUENCY RANGE	MAX 1-CYCLE PEAK SURGE
SDA-400D025I-1R	12 - 32 VDC	MAX 9.5 VDC	1.5 KΩ	25A	48 ~ 480VAC	1200VAC	LESS 10 mA	47-63HZ	315A
SDA-400D040I-1R	12 - 32 VDC	MAX 9.5 VDC	1.5 KΩ	40A	48 ~ 480VAC	1200VAC	LESS 10 mA	47-63HZ	450A
SDA-400D050I-1R	12 - 32 VDC	MAX 9.5 VDC	1.5 KΩ	50A	48 ~ 480VAC	1200VAC	LESS 10 mA	47-63HZ	560A
SDA-400D075I-1R	12 - 32 VDC	MAX 9.5 VDC	1.5 KΩ	75A	48 ~ 480VAC	1200VAC	LESS 10 mA	47-63HZ	750A
SDA-400D090I-1R	12 - 32 VDC	MAX 9.5 VDC	1.5 KΩ	90A	48 ~ 480VAC	1200VAC	LESS 10 mA	47-63HZ	900A
SDA-400D100I-1R	12 - 32 VDC	MAX 9.5 VDC	1.5 KΩ	100A	48 ~ 480VAC	1200VAC	LESS 10 mA	47-63HZ	1030A

MODEL SERIES NO.	MAX OFF STATE dv/dt	MAX ON-STATE VOLTAGE DROP	ISOLATE IMPEDENCE	DIELECTRIC STRENGTH INPUT-OUTPUT	DIELECTRIC STRENGTH INPUT-OUTPUT-CASE	TURN ON TIME	TURN OFF TIME	CAPACITANCE IN-OUT	WEIGHT (g)
SDA-400D025I-1R	500V/μsec	1.6Vrms	10 ⁹ Ω	2500 VACrms	2500 VACrms	LESS ½ msec	LESS ½ AC CYCLE	LESS 473 PF	600 g
SDA-400D040I-1R	500V/μsec	1.6Vrms	10 ⁹ Ω	2500 VACrms	2500 VACrms	LESS ½ msec	LESS ½ AC CYCLE	LESS 473 PF	600 g
SDA-400D050I-1R	500V/μsec	1.6Vrms	10 ⁹ Ω	2500 VACrms	2500 VACrms	LESS ½ msec	LESS ½ AC CYCLE	LESS 473 PF	600 g
SDA-400D075I-1R	500V/μsec	1.6Vrms	10 ⁹ Ω	2500 VACrms	2500 VACrms	LESS ½ msec	LESS ½ AC CYCLE	LESS 473 PF	600 g
SDA-400D090I-1R	500V/μsec	1.6Vrms	10 ⁹ Ω	2500 VACrms	2500 VACrms	LESS ½ msec	LESS ½ AC CYCLE	LESS 473 PF	600 g
SDA-400D100I-1R	500V/μsec	1.6Vrms	10 ⁹ Ω	2500 VACrms	2500 VACrms	LESS ½ msec	LESS ½ AC CYCLE	LESS 473 PF	600 g

PARTS NO.

SDA-400D025I-1R

- Switching Type : R = Random Switching
- Packing : 1 = Screw Type
- Phase : I = Inductive Load
- Loading Current : 025 = 25A, 040 = 40A, 050 = 50A, 075 = 75A, 090 = 90A, 100 = 100A
- Control Voltage : D = 12-32VDC
- Loading Voltage : 400 = 48~480VAC
- Control Type : DA = DC Control AC
- S = S.S.R

Outline Dimensions (Unit : mm)

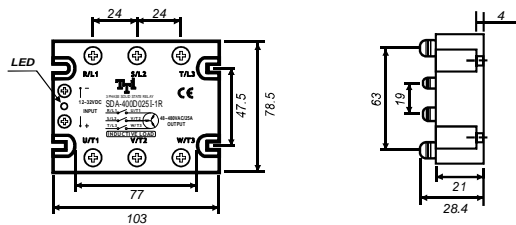

Equivalent Circuit

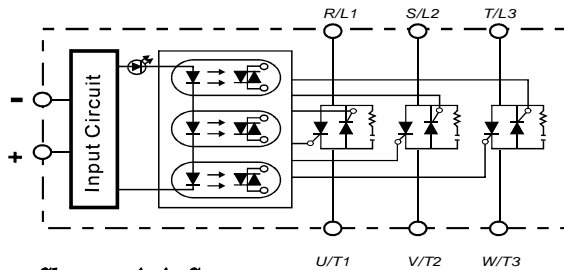

Example : 3φ S.S.R Application

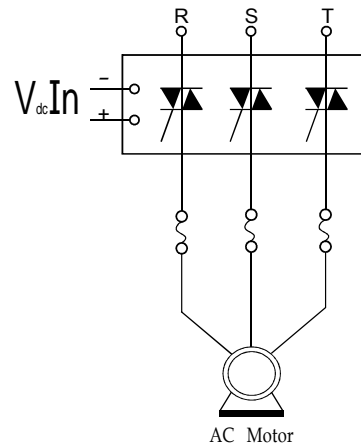

Characteristic Curves

