

φ 8.0mm Round Diffused Lamp



Characters

- Viewing angle 60°
- For LED light, indication, illumination
- UV resistant epoxy

Directive Characteristics

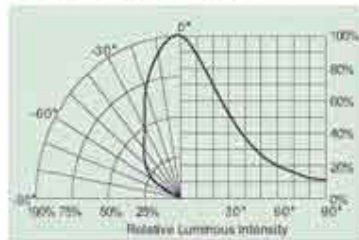

Package Outlines (Unit: mm)

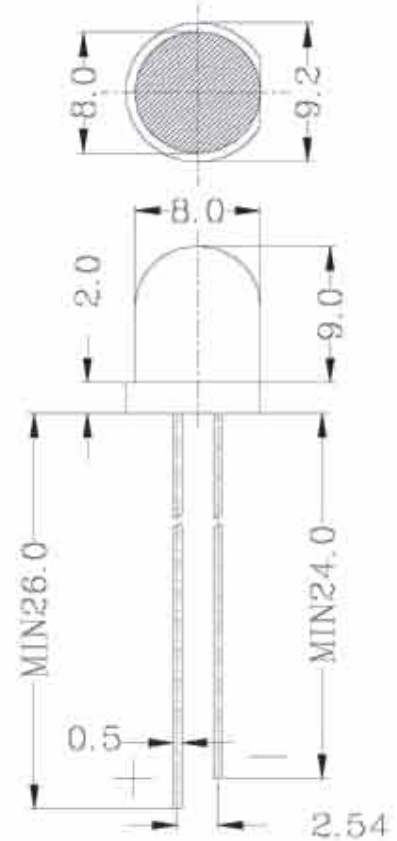

General Tolerance: ±0.2
Unless note otherwise

Absolute Maximum Ratings (Ta=25°C)

Parameter	Symbol	Value		Unit
		Green/Blue/White	Red/Orange/Yellow	
Power Dissipation	P_D	100	125	mW
DC forward Current	I_F	30	50	mA
Pulsed Forward Current	I_{FP}	100	150	mA
Reverse Voltage	V_R	5	5	V
Operating Temperature	T_{opr}	-30~+80		°C
Storage Temperature	T_{stg}	-40~+100		°C

* Duty 1/10 Pulse Width 0.1ms

Electrical Optical Characteristics (Ta=25°C)

Part Number	Material	Chip		Emitted Color	Lens Type	IF(mA)	VF(V)		IV(mcd)	
		Δp (nm)					Min	Max	Min	Max
		Min	Max							
RL80-UR533	AlGaInP/GaAs	625	635	Ultra Red	White Diffused	20	1.7	2.8	1200	3000
RL80-UO533	AlGaInP/GaAs	615	625	Ultra Orange	White Diffused	20	1.7	2.8	1200	2500
RL80-UY533	InGaAlP/GaAs	585	595	Ultra Yellow	White Diffused	20	1.7	2.8	1000	1800
RL80-GH734D	InGaN/GaN	515	525	Pure Green	White Diffused	20	3.0	3.8	4000	6000
RL80-CB734D	InGaN/GaN	465	475	Blue	White Diffused	20	3.0	3.8	3000	5000
RL80-WH734D	InGaN/GaN	Typical.x=0.3 Typical.y=0.3		White	White Diffused	20	3.0	3.8	6000	8500

* Luminous intensity rank please see 《Standard Bin Grade》

Precautions in handling

1. When soldering, leave 2.0mm of minimum clearance between the resin and the soldering point.
2. Blue, Green and White products are so sensitive to ESD, that users required to handle with care.

Package

Bulk-----200Pcs/bag

Reliability Test

No	Item	Test Condition	Test Hours/Cycles	Samples Tested	Acc./Rej
1	Room Temperature DC Operating Life	Ta=25°C,IF=20mA	1000 Hrs	76	0/1
2	Thermal Shock	-10°C(5min)→(10sec)→+100°C(5min)	100 Cycles	76	0/1
3	Temperature ycle	-40°C(30min)→(5min)→+85°C(30min)	100 Cycles	76	0/1
4	High Temp./ High Humi. Test	85°C/85%RH	1000 Hrs	76	0/1
5	High Temperature Storage	Ta=100°C	1000 Hrs	76	0/1
6	Low Temperature Storage	Ta= - 40°C	1000 Hrs	76	0/1
7	Soldering Heat	260°C ± 5°C	5 Seconds	76	0/1

Typical Electrical / Optical Characteristics Curves
 25°C Ambient Temperature Unless Otherwise Noted)
