

## φ 10.0mm Round Water Clear Lamp



### Characters

- Viewing angle 20°
- For LED light, indication, illumination
- UV resistant epoxy

### Directive Characteristics

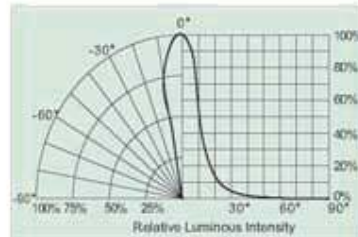

### Package Outlines (Unit: mm)

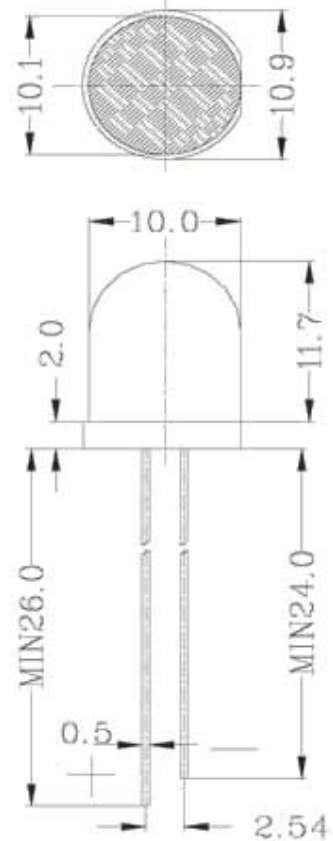

General Tolerance: ±0.2  
Unless note otherwise

### Absolute Maximum Ratings (Ta=25°C)

Parameter	Symbol	Value		Unit
		Green/Blue/White	Red/Orange/Yellow	
Power Dissipation	$P_D$	100	125	mW
DC forward Current	$I_F$	30	50	mA
Pulsed Forward Current	$I_{FP}$	100	150	mA
Reverse Voltage	$V_R$	5	5	V
Operating Temperature	$T_{opr}$	-30~+80		°C
Storage Temperature	$T_{stg}$	-40~+100		°C

\* Duty 1/10 Pulse Width 0.1ms

### Electrical Optical Characteristics (Ta=25°C)

Part Number	Material	Chip		Emitted Color	Lens Type	IF(mA)	VF(V)		IV(mcd)	
		$\Delta p$ (nm)					Min	Max	Min	Max
		Min	Max							
RL81-UR543	AlGaInP/GaAs	625	635	Ultra Red	Water Clear	20	1.7	2.8	3000	5000
RL81-UO523	AlGaInP/GaAs	615	625	Ultra Orange	Transparent	20	1.7	2.8	2500	4000
RL81-UY543	InGaAlP/GaAs	585	595	Ultra Yellow	Water Clear	20	1.7	2.8	3000	5000
RL81-GH744D	InGaN/GaN	515	525	Pure Green	Water Clear	20	3.0	3.8	7000	11000
RL81-CB744D	InGaN/GaN	465	475	Blue	Water Clear	20	3.0	3.8	5000	8000
RL81-WH744D	InGaN/GaN	Typical.x=0.3 Typical.y=0.3		White	Water Clear	20	3.0	3.8	9000	16000

\* Luminous intensity rank please see (Standard Bin Grade)

### Precautions in handling

1. When soldering, leave 2.0mm of minimum clearance between the resin and the soldering point.
2. Blue, Green and White products are so sensitive to ESD, that users required to handle with care.

### Package

Bulk-----200Pcs/bag

## Reliability Test

No	Item	Test Condition	Test Hours/Cycles	Samples Tested	Acc./Rej
1	Room Temperature DC Operating Life	Ta=25°C, IF=20mA	1000 Hrs	76	0/1
2	Thermal Shock	-10°C(5min)→(10sec)→+100°C(5min)	100 Cycles	76	0/1
3	Temperature cycle	-40°C(30min)→(5min)→+85°C(30min)	100 Cycles	76	0/1
4	High Temp./ High Humi. Test	85°C/85%RH	1000 Hrs	76	0/1
5	High Temperature Storage	Ta=100°C	1000 Hrs	76	0/1
6	Low Temperature Storage	Ta= - 40°C	1000 Hrs	76	0/1
7	Soldering Heat	260°C±5°C	5 Seconds	76	0/1

Typical Electrical / Optical Characteristics Curves  
25°C Ambient Temperature Unless Otherwise Noted)

