

Switching Charger for 1-Cell and 2-Cell Li-ion Batteries

ISL9220, ISL9220A

The ISL9220, ISL9220A is a cost-effective and versatile battery charger for 1-cell and 2-cell Li-ion and Li-Polymer based portable applications.

The device features synchronous PWM technology, maximizing power efficiency, thus minimizing charge time and heat. The 1.2MHz switching frequency allows use of small external inductors and capacitors.

A simple charge current programming method is provided. External resistors program the fast charge and end-of-charge currents.

The two status outputs can be used to drive LEDs, or can be connected to host processor.

A programmable charge timer provides the ability to detect defective batteries, and provides a secondary method of detecting charge termination.

A thermistor interface is provided for battery presence detection, and for temperature qualified charging conditions.

Additional features include preconditioning of an over-discharged battery, automatic recharge, and thermally enhanced QFN package.

Applications

- PDAs and Smart Phones
- MP3 and Portable Media Players
- Handheld GPS Devices
- Digital Still Cameras
- Industrial Handheld Scanners

Features

- Highly Integrated Battery Charger IC
- Charges 1- and 2-Cell Li-ion or Li-Polymer Batteries
- Up to 2A Charge Current
- Synchronous Buck Topology with Integrated Power FETs
- 1.2MHz Switching Frequency
- 0.5% Charge Voltage Accuracy
- Programmable Input Current Limit with One External Resistor
- Thermistor Interface for Battery Detection and Temperature Qualified Charging
- Two Status Outputs
- Programmable Charge Safety Timer
- Short-Circuit and Thermal Protection
- Small 4mmx4mm TQFN Package
- -40°C to +85°C Operating Temperature Range

Related Literature

- Technical Brief [TB363](#) "Guidelines for Handling and Processing Moisture Sensitive Surface Mount Devices (SMDs)"
- Technical Brief [TB379](#) "Thermal Characterization of Packaged Semiconductor Devices"
- Technical Brief [TB389](#) "PCB Land Pattern Design and Surface Mount Guidelines for QFN Packages"

Pin Configuration

ISL9220, ISL9220A
(20 LD TQFN)
TOP VIEW

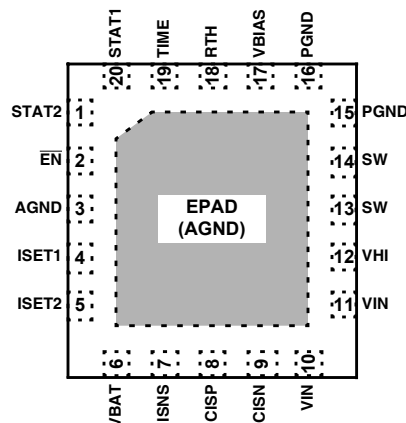

Pin Descriptions

PIN	SYMBOL	DESCRIPTION
1	STAT2	Open-drain indication pin. In conjunction with STAT1 this pin provides a unique indication for each charging state of the cycle. This pin is capable to sink 10mA minimum current to drive an LED.
2	$\overline{\text{EN}}$	IC enable input. Drive this pin to logic LO to enable the charger. Drive this pin to logic HI to disable the charger. Do not leave this pin floating.
3	AGND	Analog ground.
4	ISET1	Charge current programming pin. Connect a resistor between this pin and the GND pin to set the charge current.
5	ISET2	End-of-charge current programming pin. Connect a resistor between this pin and the GND pin to set the end-of-charge current.
6	VBAT	Battery connection pin. Connect this pin to the battery. A 10 μ F or larger X5R ceramic capacitor is recommended for decoupling and stability purposes.
7	ISNS	Output current sense pin. Connect a current sense resistor from this pin to V _{BAT} . No decoupling capacitor is needed at this pin.
8	CISP	Input current sense positive connection pin. Connector a sense resistor from this pin the CISP.
9	CISN	Input current sense negative connection pin. Connector a sense resistor from this pin the CISP.
10, 11	VIN	Input supply voltage. Connect a 4.7 μ F ceramic capacitor from VIN to PGND.
12	VHI	High side NMOS FET gate drive supply pin. Connect a Schottky diode from VBIAS to this pin, and a 0.1mF capacitor to AGND, as shown in the Typical Application Circuits.
13, 14	SW	Switch node and inductor connection pin.
15, 16	PGND	Power ground.
17	VBIAS	Internal 5V regulator output. Connect a 1 μ F ceramic capacitor from this pin to AGND.
18	RTH	Input for an external NTC thermistor for battery temperature monitoring.
19	TIME	The TIME pin sets the oscillation period by connecting a timing capacitor between this pin and GND. The oscillator also provides a time reference for the charger. The timer function can be disabled by connecting the TIME pin to GND. If the timer is disabled, there will be no timeout function for any operation mode including trickle charge and fast charge modes.
20	STAT1	Open-drain indication pin. In conjunction with STAT2 this pin provides a unique indication for each charging state of the cycle. This pin is capable to sink 10mA minimum current to drive an LED.
	EPAD	Exposed pad. Connect to GND electrically. Thermally, connect as much as possible copper to this pad either on the component layer or other layers through thermal vias to enhance the thermal performance.

Ordering Information

PART NUMBER (Notes 1, 2, 3)	PART MARKING	TEMP. RANGE (°C)	PACKAGE Tape & Reel (Pb-free)	PKG. DWG. #
ISL9220IRTZ-T	92 20IRTZ	-40 to +85	20 Ld 4x4 TQFN	L20.4x4E
ISL9220AIRTZ-T	922 0AIRTZ	-40 to +85	20 Ld 4x4 TQFN	L20.4x4E
ISL9220EVAL1Z	Evaluation Board			
ISL9220AEVAL1Z	Evaluation Board			

NOTES:

1. Please refer to [TB347](#) for details on reel specifications.
2. These Intersil Pb-free plastic packaged products employ special Pb-free material sets, molding compounds/die attach materials, and 100% matte tin plate plus anneal (e3 termination finish, which is RoHS compliant and compatible with both SnPb and Pb-free soldering operations). Intersil Pb-free products are MSL classified at Pb-free peak reflow temperatures that meet or exceed the Pb-free requirements of IPC/JEDEC J STD-020.
3. For Moisture Sensitivity Level (MSL), please see device information page for [ISL9220, ISL9220A](#). For more information on MSL please see techbrief [TB363](#).

ISL9220, ISL9220A

Absolute Maximum Ratings

VIN, CISP, CISN	-0.3V to 18V
SW	-0.7V to 18V
VHI	-0.3V to 24V
VBAT, ISNS	-0.3V to 10V
ISET1, ISET2, RTH, VBIAS, STAT1, STAT2, EN	-0.3V to 5.5V
TIME	-0.3V to 2.75V
Input Current (VIN)	2.0A
Output Current (SW)	2.2A
ESD Rating	
Human Body Model (Tested per JESD22-A114F)	2500V
Machine Model (Tested per EIA/JESD22-A115-A)	175V
Charged Device Model (Tested per JES22-C101D)	1500V
Latch-Up	
(Tested per JESD-78B; Class 2 (+85°C), Level A)	100mA

Thermal Information

Thermal Resistance (Typical)	θ_{JA} (°C/W)	θ_{JC} (°C/W)
4x4 QFN Package (Notes 4, 5)	40	4.3
Maximum Junction Temperature (Plastic Package)	+150°C	
Maximum Storage Temperature Range	-65°C to +150°C	
Pb-Free Reflow Profile	see link below	
	http://www.intersil.com/pbfree/Pb-FreeReflow.asp	

Recommended Operating Conditions

Ambient Temperature Range	-40°C to +85°C
Supply Voltage, VIN	
ISL9220	4.5V to 14V
ISL9220A	9V to 14V
Programmable Charge Current	200mA to 2A
Programmable Trickle Current	20mA to 200mA

CAUTION: Do not operate at or near the maximum ratings listed for extended periods of time. Exposure to such conditions may adversely impact product reliability and result in failures not covered by warranty.

NOTES:

- θ_{JA} is measured in free air with the component mounted on a high effective thermal conductivity test board with "direct attach" features. See Tech Brief TB379.
- θ_{JC} , "case temperature" location is at the center of the exposed metal pad on the package underside.

Electrical Specifications Typical specifications are measured at the following conditions: $T_A = +25^\circ\text{C}$; For ISL9220, $V_{IN} = 5\text{V}$; For ISL9220A, $V_{IN} = 12\text{V}$.

PARAMETER	SYMBOL	TEST CONDITIONS	MIN	TYP	MAX	UNITS
POWER-ON RESET						
Rising V_{IN} Threshold	V_{POR_R}		3.4	3.6	3.8	V
Falling V_{IN} Threshold	V_{POR_F}		2.2	2.4	2.6	V
VIN - VBAT OFFSET VOLTAGE						
Rising Offset Threshold	V_{OS_R}	ISL9220	-	95	150	mV
		ISL9220A	-	170	300	mV
Falling Offset Threshold	V_{OS_F}	ISL9220	10	65	-	mV
		ISL9220A	20	130	-	mV
SUPPLY CURRENT						
VIN Pin Supply Current	$I_{CC(VIN)}$	PGOOD = TRUE, $\overline{EN} = L$ (Note 6)		10	15	mA
		PGOOD = TRUE, $\overline{EN} = H$ (Note 6) $V_{IN} = 5\text{V to }12\text{V}$	-	-	0.5	mA
Battery Discharge Current (Total of currents flowing into VBAT, ISNS, SW pins)	I_{DIS}	$V_{IN} < V_{POR}$ OR $\overline{EN} = H$ $2\text{V} < V_{BAT} < 11\text{V}$	-	2	5	μA
OVERVOLTAGE PROTECTION						
Input OVP Rising Threshold	V_{IN_OVPR}		14.5	15.0	15.5	V
Input OVP Falling Threshold	V_{IN_OVPF}		14.0	14.5	15.0	V
OUTPUT CURRENT						
Fast Charge Current Accuracy	I_{CHG}	RSNS = 0.039 Ω RISET1 = 49.9k Ω (Nominal) $I_{OUT} = 1000\text{mA}$	-10	-	10	%
Charge Termination Current Accuracy	I_{MIN}	RSNS = 0.039 Ω RISET2 = 300k Ω (Nominal) $I_{MIN} = 100\text{mA}$	-35	-	35	%

ISL9220, ISL9220A

Electrical Specifications Typical specifications are measured at the following conditions: $T_A = +25^\circ\text{C}$; For ISL9220, $V_{IN} = 5\text{V}$; For ISL9220A, $V_{IN} = 12\text{V}$. **(Continued)**

PARAMETER	SYMBOL	TEST CONDITIONS	MIN	TYP	MAX	UNITS
Charge Termination Detection Deglitch Time			-	12	-	ms
Level 1 Pre-Charge Current Range (Linear mode)	I_{PCHG1}	$V_{BAT} < V_{PCHG1}$	25	50	90	mA
Level 2 Pre-Charge Current Accuracy	I_{PCHG2}	$RSNS = 0.039\Omega$ $R_{ISET2} = 300k\Omega$ (Nominal) $I_{PCHG} = 140\text{mA}$	-	± 20	-	%
Level 1 Pre-Charge Threshold Voltage	V_{PCHG1}	ISL9220	2.42	2.5	2.56	V
		ISL9220A	4.8	5.0	5.3	V
Level 2 Pre-Charge Threshold Voltage	V_{PCHG2}	ISL9220	2.9	3.0	3.1	V
		ISL9220A	5.75	6.0	6.25	V
RECHARGE THRESHOLD						
Recharge Voltage Threshold	V_{RECHG}	ISL9220	3.85	4.0	4.1	V
		ISL9220A	7.75	8.0	8.25	V
TEMPERATURE MONITORING						
High Battery Temperature Threshold	V_{TMIN}	Specified as % of V_{BIAS}	30	35	40	%
Low Battery Temperature Threshold	V_{TMAX}	Specified as % of V_{BIAS}	70	75	80	%
Battery Removal Threshold	V_{RMV}	Specified as % of V_{BIAS}	90	95	-	%
Thermistor Disable Threshold	V_{T_DIS}		-	250	-	mV
Temperature Threshold Hysteresis	$V_{T,HYS}$		-	180	-	mV
Temperature Detection Deglitch Time			-	12	-	ms
THERMAL PROTECTION						
Thermal Shutdown Threshold	T_{FD}		-	140	-	$^\circ\text{C}$
Thermal Hysteresis	T_{HYS}		-	30	-	$^\circ\text{C}$
VBIAS OUTPUT						
Output Voltage	V_{BIAS}	$5.3 < V_{IN} < 15\text{V}$, $I_{VBIAS} = 5\text{mA}$	4.70	5.0	5.25	V
Output Current	I_{BIAS}	$5.3 < V_{IN} < 15\text{V}$	-	-	5	mA
OSCILLATOR						
Oscillation Period	t_{OSC}	$C_{TIME} = 15\text{nF}$	-	3.0	-	ms
SWITCHING CHARGER AC CHARACTERISTICS						
Switching Frequency	F_{OSC}		1.02	1.2	1.38	MHz
Maximum Duty Cycle	D_{MAX}		-	96	-	%
Minimum Duty Cycle	D_{MIN}		-	0	-	%
Cycle-By-Cycle Current Limit	I_{LIM}		-	3.0	-	A
SWITCHING CHARGER DC CHARACTERISTICS						
High-Side MOSFET ON-Resistance	$r_{DS(ON), HS1}$		-	112	-	$m\Omega$
Combined High Side ON-Resistance (Note 7)	$r_{DS(ON), HS2}$	Measured between V_{IN} and SW pins	-	224	450	$m\Omega$
Low-Side MOSFET ON-Resistance	$r_{DS(ON), L}$		-	72	180	$m\Omega$
High-Side Path Reverse Leakage Current	I_{REV}	$V_{IN} = 0\text{V}$, $V_{SW} = 15\text{V}$	-	1.0	5.0	μA

ISL9220, ISL9220A

Electrical Specifications Typical specifications are measured at the following conditions: $T_A = +25^\circ\text{C}$; For ISL9220, $V_{IN} = 5\text{V}$; For ISL9220A, $V_{IN} = 12\text{V}$. **(Continued)**

PARAMETER	SYMBOL	TEST CONDITIONS	MIN	TYP	MAX	UNITS
Charger Output Voltage	V_{CHG}	ISL9220, $I_{OUT} = 100\text{mA}$, $T_A = +25^\circ\text{C}$	4.179	4.2	4.221	V
		ISL9220A, $I_{OUT} = 100\text{mA}$, $T_A = +25^\circ\text{C}$	8.358	8.4	8.442	V
		ISL9220, $I_{OUT} = 100\text{mA}$	4.158	4.2	4.242	V
		ISL9220A, $I_{OUT} = 100\text{mA}$	8.316	8.4	8.484	V
INPUT CURRENT SENSE AMPLIFIER						
Input Bias Current at CSIP and CSIN, Pin (Charger Enabled)	I_{ISIP_ON}	$\overline{EN} = L$	-	100	200	μA
Input Current Limit Threshold	I_{IN_LIM}	CSIP-CSIN	88	100	112	mV
OUTPUT CURRENT SENSE AMPLIFIER						
Input Bias Current at ISNS Pin, (Charger Enabled)	I_{ISNS_ON}	$\overline{EN} = L$	-	100	200	μA
Input Bias Current at ISNS Pin, (Charger Disabled)	I_{ISNS_OFF}	$\overline{EN} = H$	-	-	1	μA
Input Bias Current at VBAT Pin, (Charger Enabled)	I_{VBAT_ON}	$\overline{EN} = L$	-	75	100	μA
Input Bias Current at VBAT Pin, (Charger Disabled)	I_{VBAT_OFF}	$\overline{EN} = H$	-	-	1	μA
LOGIC INPUT AND OUTPUTS						
\overline{EN} Pin Logic High			1.3	-	-	V
\overline{EN} Pin Logic Low			-	-	0.4	V
STAT1, STAT2 Sink Current When ON		Pin Voltage = 0.4V	10	-	-	mA
STAT1, STAT2 Leakage Current When OFF		Pin Voltage = 4.2V	-	-	1	μA

NOTES:

- PGOOD is defined as when V_{IN} and V_{BAT} meet all these conditions: $V_{IN} > VPOR$, $V_{IN} - V_{BAT} > VOS$, $V_{IN} < V_{IN(OVP)}$.
- Limits should be considered typical and are not production tested.

Typical Applications Diagrams

1-Cell Application

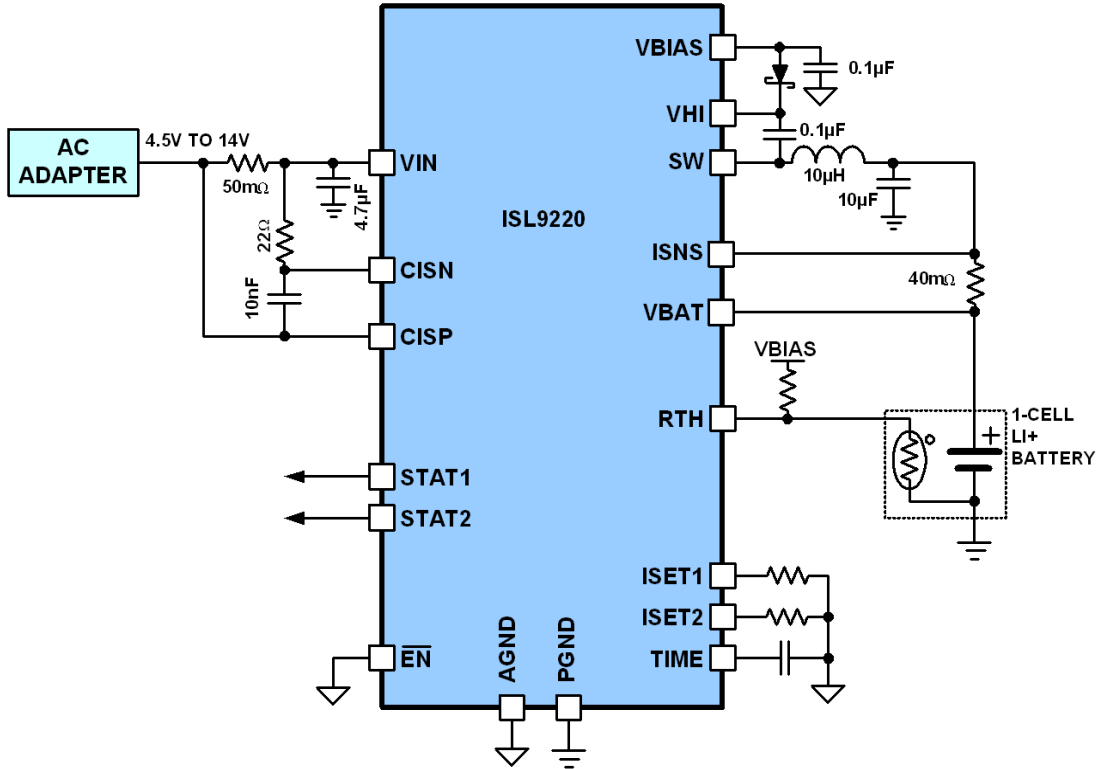

2-Cell Application

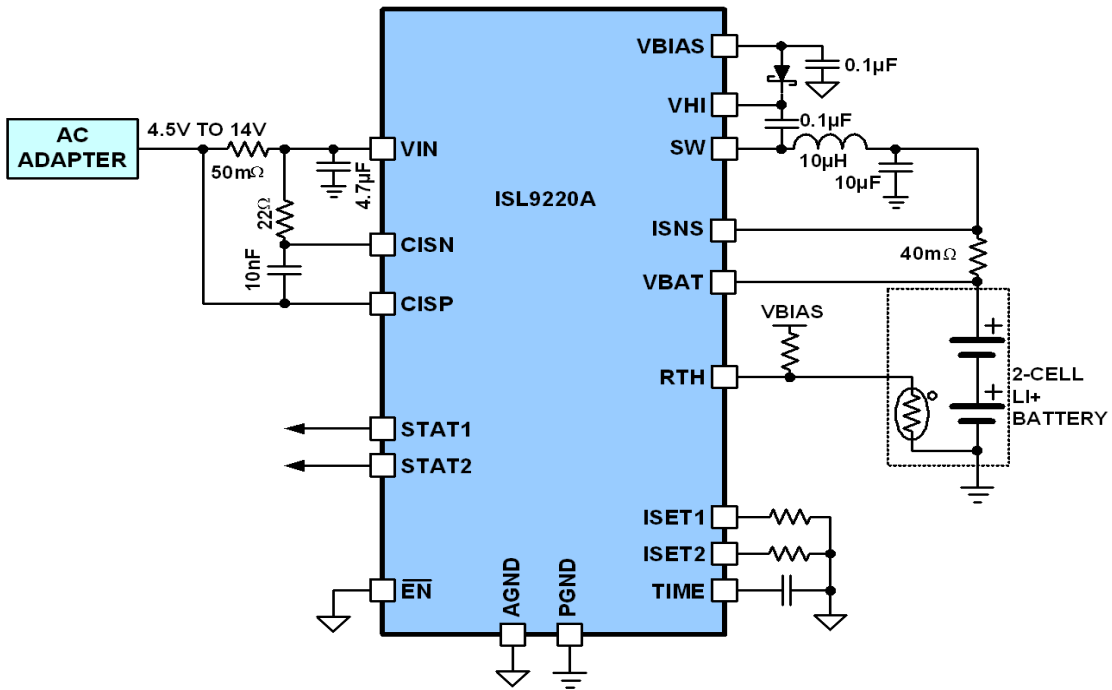

Block Diagram

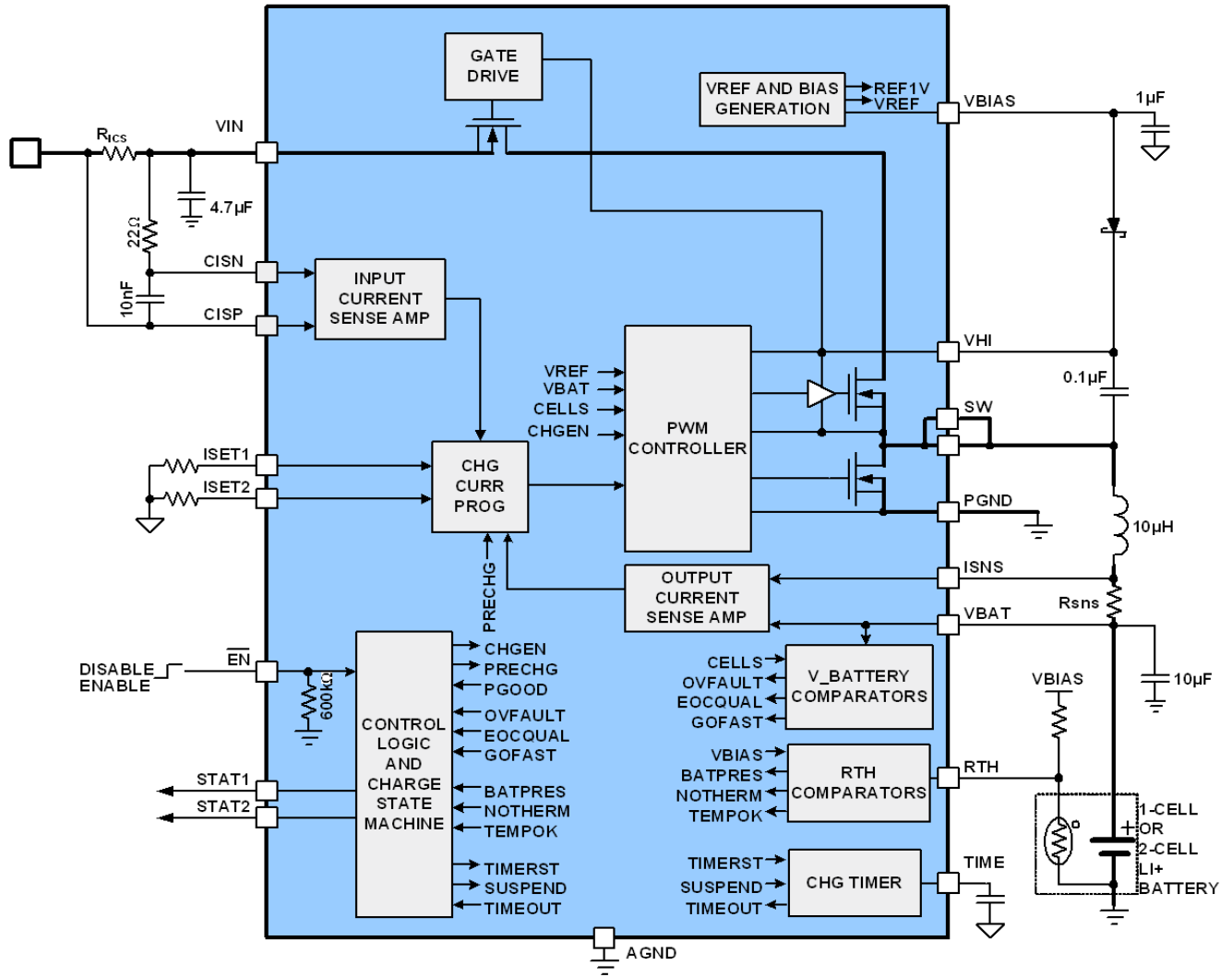

Typical Operating Conditions

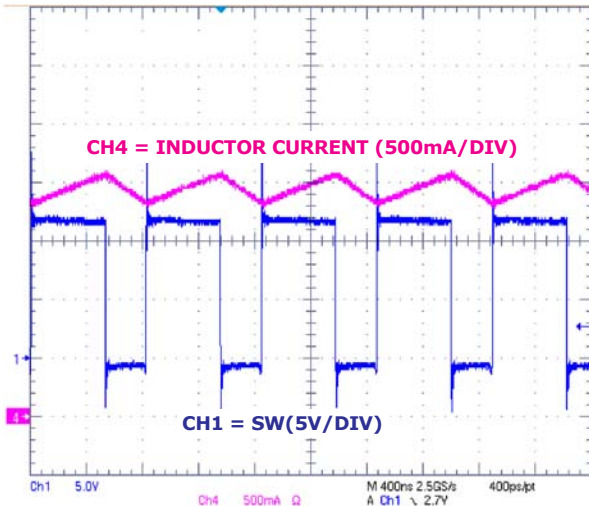

FIGURE 1. PWM WAVEFORM IN CC MODE

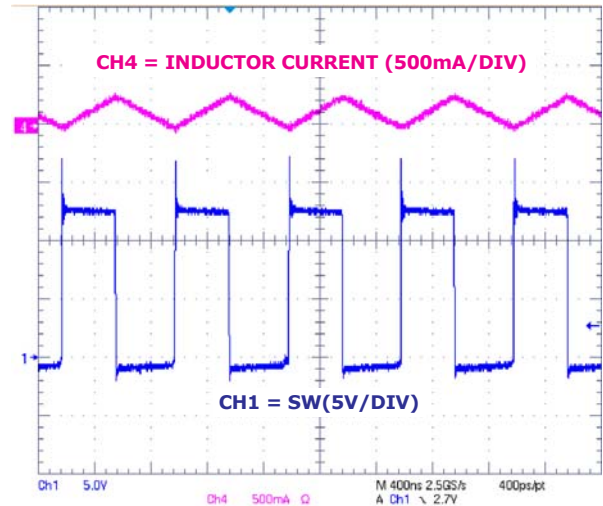

FIGURE 2. PWM WAVEFORM IN TRICKLE MODE

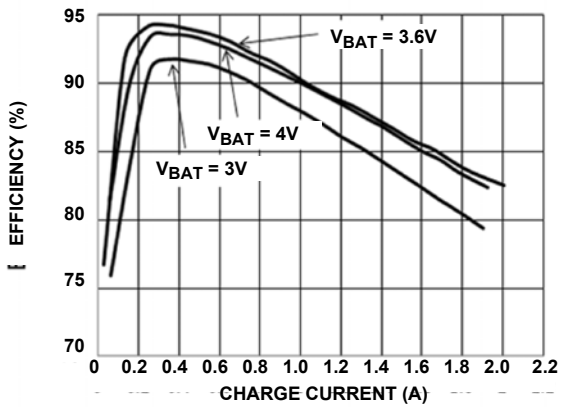

FIGURE 3. EFFICIENCY vs LOAD 1-CELL ($V_{IN} = 5V$, $L = 10\mu H$)

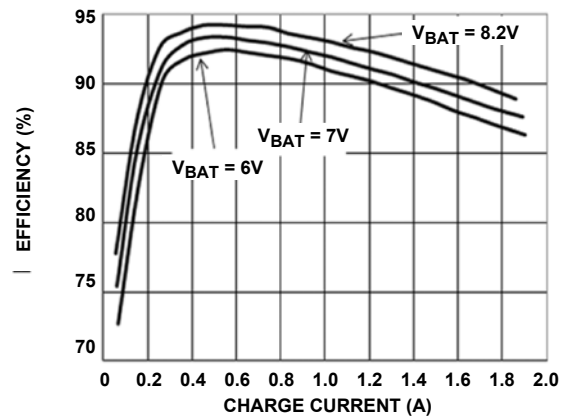

FIGURE 4. EFFICIENCY vs LOAD 2-CELL ($V_{IN} = 12V$, $L = 10\mu H$)

Theory of Operation

The ISL9220, ISL9220A is an integrated charger optimized for charging 1-cell and 2-cell Li-ion or Li-polymer batteries. It charges a battery with constant current (CC) and constant voltage (CV) profile. The typical charge profile is illustrated in Figure 5.

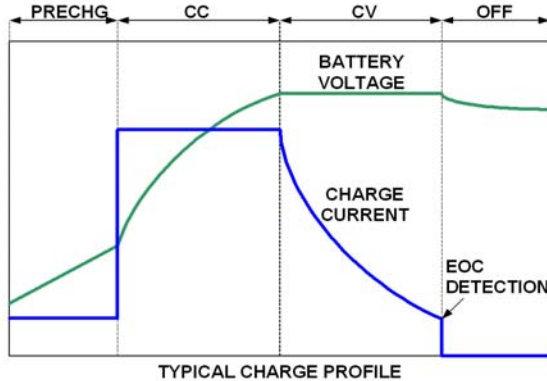

FIGURE 5. TYPICAL CHARGE PROFILE

POR and Power-Good

The ISL9220, ISL9220A resets itself when V_{IN} undergoes transition from below V_{POR} to above V_{POR} threshold.

The ISL9220, ISL9220A has an internal PGOOD signal. Charging is prohibited if PGOOD statement is not true. See Note 6 in the "Electrical Specifications" table for definition of PGOOD.

Valid Charge Temperatures

An external NTC thermistor can be used to provide temperature-qualified charging. The V_{BIAS} supply is used as reference for the internal comparators. Thus, it is important that the V_{BIAS} supply also be used to bias the external voltage divider comprised of one or more fixed resistors and the thermistor. This scheme allows the use of a wide variety of thermistors. The RTH comparator block monitors the RTH pin voltage to determine if the battery temperature is within safe charging limits.

The ISL9220, ISL9220A uses two comparators (CP2 and CP3) to form a window comparator, as shown in Figure 6. When the NTC pin voltage is "out of the window," determined by the V_{TMIN} and V_{TMAX} , the ISL9220, ISL9220A stops charging and indicate a suspend condition. When the temperature returns to the set range, the charger resumes charging. The two MOSFETs, Q1 and Q2, produce hysteresis for both upper and lower thresholds. The temperature window is shown in Figure 7 for a 0°C to +50°C typical application using an industry standard type 103AT thermistor.

The temperature qualification function can be disabled by connecting the RTH pin to ground.

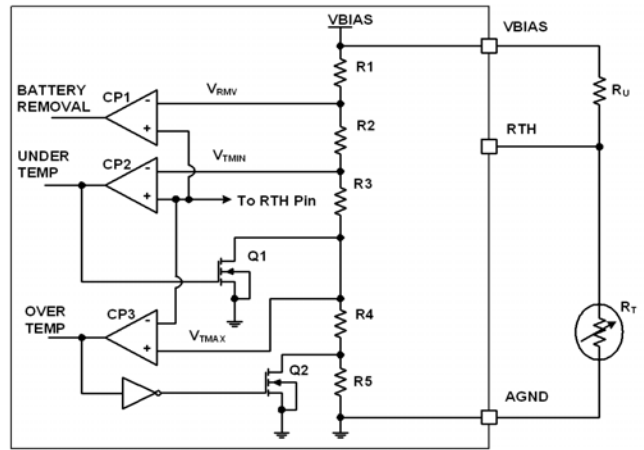

FIGURE 6. THERMISTOR INTERNAL CIRCUIT

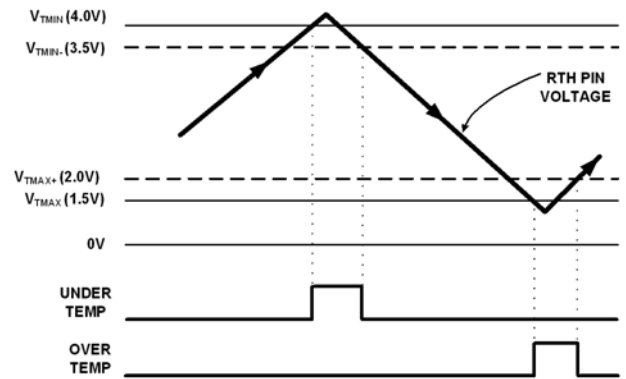

FIGURE 7. THRESHOLD VOLTAGES FOR 0°C to +50°C WINDOW ($V_{BIAS} = 5.0V$)

Battery Detection

The presence or absence of the external thermistor is used to detect a battery.

When V_{RTH} is greater than $V_{RTH,PRES}$, i.e. when RTH pin is not connected to ground, battery detection is provided by the RTH comparator block, as shown in Figure 6. With no battery connected, the RTH pin is pulled to V_{BIAS} by R_U , and thus V_{RTH} will exceed the $V_{RTH,NOBAT}$ threshold. The internal battery presence signal is deglitched with a 12ms deglitcher, to avoid false indication of battery insertion or removal due to contact bounce or other noises.

Battery Precharge

When the charger is first enabled and no fault conditions are detected, If the battery connecting to the charger is deeply discharged, the charger will charge the battery in a reduced current for the battery to recover.

If battery voltage is less than the level 1 pre-charge voltage (V_{PCHG1}), the charger operates in LDO mode, with an output current fixed at 50mA typical. In this mode the output voltage can go to 0V. This provides the ability to recover a battery that has entered a safety-circuit undervoltage fault mode.

$$I_{PCHG1} = 50\text{mA} \quad (\text{EQ. 1})$$

If battery voltage is between the level 1 pre-charge voltage (V_{PCHG1}) and level 2 pre-charge voltage (V_{PCHG2}), the charger operates in trickle mode, and uses the precharge current limit. This precharge current is programmed by the resistor between the ISET2 pin and ground. Note that this resistor also programs the end-of-charge taper current threshold.

$$I_{PCHG2} = \frac{1638}{R_{ISET2} \times R_{SNS}} \quad (\text{mA}) \quad (\text{EQ. 2})$$

Where R_{ISET2} is in $k\Omega$ and R_{SNS} is in Ω .

When the battery voltage exceeds the level 2 pre-charge voltage threshold (V_{PCHG2}), fast charging will commence. If this threshold is not reached within the precharge timer period, a TIME-OUT-FAULT condition is asserted, and the charger is disabled.

Charge Safety Timer

An internal oscillator establishes a timing reference. The oscillation period is programmable with an external capacitor at the TIME pin, C_{Time} , as shown in "Typical Applications Diagrams" on page 6. The oscillator charges the timing capacitor to 1.5V and then discharges it to 0.5V in one period, both with $10\mu\text{A}$ current. The period t_{OSC} is calculated in Equation 3:

$$t_{OSC} = 0.2 \times 10^6 \times C_{Time} \quad (\text{Sec}) \quad (\text{EQ. 3})$$

Where C_{Time} is in F.

A 1nF capacitor provides 0.2ms oscillation period. The allowable range of C_{Time} value is 100pF to $1\mu\text{F}$, providing a programmable charge safety-timeout range of about 1.4 minutes to almost 10 days.

Total charge time, excluding any time required for precharge, is limited to a length of TIMEOUT. This can be calculated as Equation 4:

$$\text{TIMEOUT} = 2^{22} \times t_{OSC} \quad (\text{Sec}) \quad (\text{EQ. 4})$$

Total charge time for battery precharge is limited to a length of 1/8 TIMEOUT. This can be calculated as Equation 5:

$$\text{TIMEOUT(PCHG)} = 2^{19} \times t_{OSC} \quad (\text{Sec}) \quad (\text{EQ. 5})$$

The TIME pin can be grounded to disable the safety timer functions if not needed.

Fast Charge

The fast charge current is programmed by the resistor between the ISET1 pin and ground, and by the value of the R_{SNS} resistor (see Equation 6).

$$I_{CHG} = \frac{1946}{R_{ISET1} \times R_{SNS}} \quad (\text{mA}) \quad (\text{EQ. 6})$$

Where R_{ISET1} is in $k\Omega$ and R_{SNS} is in Ω .

For best accuracy, select R_{SNS} value that provides between 40mV to 80mV differential voltage across R_{SNS} at the desired maximum peak current (DC plus ripple).

Charge Termination

Charge current is continuously monitored. When the current falls below the taper current threshold, charging will stop, and BATFUL is asserted to indicate a successful charge completion. This taper current threshold is programmed by a single external resistor between ISET2 and ground as calculated in Equation 7.

$$I_{EOC} = \frac{1170}{R_{ISET2} \times R_{SNS}} \quad (\text{mA}) \quad (\text{EQ. 7})$$

Where R_{ISET2} is in $k\Omega$ and R_{SNS} is in Ω .

A secondary charge termination method is provided via the safety timer. The timeout period of this timer is programmable via a single external capacitor between the TIME pin and ground.

To disable the charge safety timer, short the TIME pin to ground.

Charge Current Sensing

Charge current is sensed with an external current sense resistor. A low-inductance, precision resistor should be used for accurate charge current.

Input Current Sensing

Input current is sensed with an external sense resistor. A low-inductance, precision resistor should be used for accurate input current limit.

The ISL9220, ISL9220A limits the battery charge current when the input current limit threshold is exceeded. This allows the most efficient use of AC-adaptor power without overloading the adaptor output.

An internal amplifier compares the voltage between CSIP and CSIN, and reduces the output current when this differential voltage exceeds the threshold voltage. The effective input current limit threshold is thus set by the value of the R_{ICS} resistor as calculated by Equation 8.

$$I_{IN(LIM)} = \frac{0.1}{R_{ICS}} \quad (\text{A}) \quad (\text{EQ. 8})$$

Where R_{ICS} is in Ω .

A low pass filter is suggested to eliminate the switching noise, as shown in "Typical Applications Diagrams" on page 6.

Status Outputs

TABLE 1. STAT1 AND STAT2 TRUE TABLE

STAT1	STAT2	CHARGING CONDITION
L	L	Precharge, or fast charge in progress
L	H	Charge Complete
H	L	Fault
H	H	Suspend

STAT1 and STAT2 are configured to indicate various charging conditions as given in Table 1.

A fault status is triggered under one of these conditions:

1. $V_{BAT} > V_{OUT_OVP}$ threshold
2. Timeout occurs before the EOC current has been reached

To exit the fault mode, the input power has to be recycled, or the \overline{EN} pin is toggled to HI and back to LO.

Applications Information

Power-On Reset (POR)

The ISL9220, ISL9220A resets itself as the input voltage rises above the POR rising threshold. The internal oscillator starts to oscillate, the internal timer is reset, and the charger begins to charge the battery. The STAT1/2 pins will indicate the operating condition according to Table 1.

Trickle Charge

If the battery voltage is below the trickle charge threshold, the ISL9220, ISL9220A delivers a small current to charge the battery until the battery voltage reaches the fast charge threshold value. There are two trickle charge thresholds. The first threshold, V_{PCHG1} , is to pre-charge a deeply discharged battery or short circuit. The second threshold, V_{PCHG2} is for batteries discharged to a voltage range from 2.5V to 3V. When V_{BAT} is below V_{PCHG1} , the ISL9220, ISL9220A operates as a linear regulator, providing a 50mA constant current to output. When V_{BAT} reaches V_{PCHG2} , the ISL9220, ISL9220A starts to operate as a switching charger. The trickle charge current is programmable by Riset2.

Charge Cycle

A charge cycle consists of three charge modes: trickle mode, constant current (CC) mode, and constant voltage (CV) mode. The charge cycle always starts with the trickle mode until the battery voltage stays above V_{MIN} (3.0V typical). If the battery voltage stays below V_{MIN} , the charger stays in the trickle mode. The charger operates in CC mode after the battery voltage is above V_{MIN} . As the battery-pack terminal voltage rises to the final charge voltage, the CV mode operation begins. Since the battery terminal voltage is regulated at the constant output voltage in the CV mode, the charge current begins to drop. After the charge current drops below the end-of-charge level, which is programmed by Riset2. The ISL9220, ISL9220A indicates the end-of-charge (EOC) with STAT1 and STAT2 and terminates the charge. The following events initiate a new charge cycle:

- POR
- A new battery being inserted (detected by RTH pin)
- Recovery from an battery over-temperature fault
- The \overline{EN} pin is toggled from HI-to-LO

Recharge

After a charge cycle completes at a timeout event, charging is prohibited until the recharge condition ($V_{BAT} < V_{RECHG}$) is met, then the charging restarts with the timer reset to zero.

Inductor and Output Capacitor Selection

To achieve better steady state and transient response, ISL9220, ISL9220A typically uses a 10μH inductor. The peak-to-peak inductor current ripple can be expressed in Equation 9:

$$\Delta I = \frac{V_{BAT} \cdot \left(1 - \frac{V_{BAT}}{V_{IN}}\right)}{L \cdot f_S} \quad (\text{EQ. 9})$$

In Equation 9, usually the typical values can be used but to have a more conservative estimation, the inductance should consider the value with worst case tolerance; and for switching frequency f_S , the minimum f_S from the "Electrical Specifications" table on page 3 can be used. A worst case for charge current ripple is when battery voltage is half of the input voltage.

To select the inductor, its saturation current rating should be at least higher than the sum of the maximum output current and half of the delta calculated from Equation 9. Another more conservative approach is to select the inductor with the current rating higher than the peak current limit.

Another consideration is the inductor DC resistance since it directly affects the efficiency of the converter. Ideally, the inductor with the lower DC resistance should be considered to achieve higher efficiency.

Inductor specifications could be different from different manufacturers so please check with each manufacturer if additional information is needed.

For the output capacitor, a ceramic capacitor can be used because of the low ESR values, which helps to minimize the output voltage ripple. A typical value of 10μF/10V ceramic capacitor should be enough for most of the applications and the capacitor should be X5R or X7R.

Board Layout Recommendations

The ISL9220, ISL9220A is a high frequency switching charger and hence the PCB layout is a very important design practice to ensure a satisfactory performance.

The power loop is composed of the output inductor L, the output capacitor C_{OUT} , the SW pin and the PGND pin. It is important to make the power loop as small as possible and the connecting traces among them should be direct, short and wide; the same practice should be applied to the connection of the VIN pin, the input capacitor C_{IN} and PGND.

The switching node of the converter, the SW pin, and the traces connected to this node are very noisy, so keep the voltage feedback trace and other noise sensitive traces away from these noisy traces.

The input capacitor should be placed as close as possible to the VIN pin. The ground of the input and output capacitors should be connected as close as possible as well. In addition, a solid ground plane is helpful for a good EMI performance.

The ISL9220, ISL9220A employs a thermal enhanced QFN package with an exposed pad. In order to maximize the current capability, it is very important that the exposed pad under the package is properly soldered to the board and is connected to other layers through thermal vias. More thermal vias and more copper attached to the exposed pad usually results in better thermal performance. The exposed pad is big enough for 5 vias as shown in Figure 8.

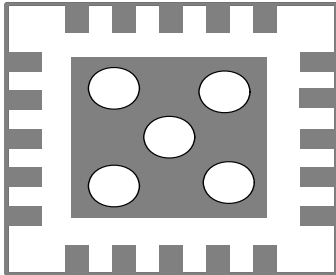

FIGURE 8. EXPOSED PAD

Charging Flow Chart

The charging flow chart is shown in Figure 9. The charging starts with the trickle mode, the ISL9220, ISL9220A charges the battery in a trickle current. If V_{BAT} reaches V_{PCHG2} before the trickle charge timeout interval, the operation will change to CC mode. When the output voltage reaches the 4.2V final voltage, the operation will change to CV mode, where the battery is charged at a constant voltage. If the end-of-charge current is reached before the timeout interval is elapsed, the operation will come to charge complete state. The charging is terminated. After the termination, if the output voltage drops below the recharge threshold, a recharge starts and the timer is reset to zero.

In the event that the timeout condition is reached before EOC, the fault mode is entered. The fault mode can also be triggered by a V_{BAT} OVP event. To exit the fault mode, the input power has to be removed and re-applied, or the \overline{EN} pin is toggled to HI and back to LO, then a new cycle starts.

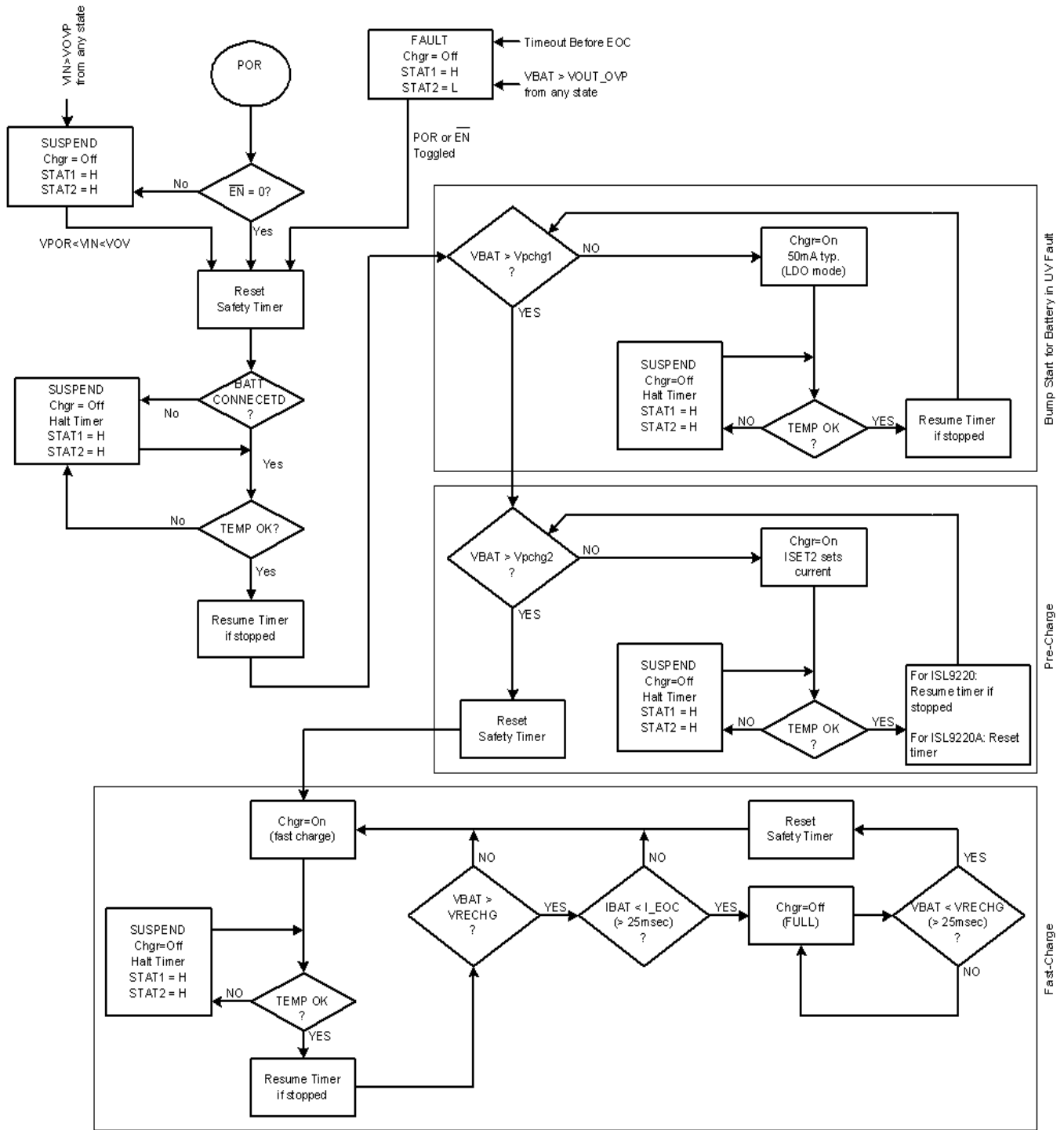

FIGURE 9. CHARGING FLOW CHART

Revision History

The revision history provided is for informational purposes only and is believed to be accurate, but not warranted. Please go to web to make sure you have the latest Rev.

DATE	REVISION	CHANGE
7/1/10	FN6936.1	Changed minimum limit for "IPCHG1" on page 4 from 30 to 25mA. On page 4, changed "Minimum On-Time" with typical 20ns to "Minimum Duty Cycle" with typical of 0%. Changed minimum limit for "VPCHG1" on page 4 from 4.85 to 4.80V for only the "A option" Changed maximum limit for "VPCHG1" on page 4 from 5.25 to 5.3V for only the "A option" Changed minimum limit for "VPCHG2" on page 4 from 5.80V to 5.75V for only the "A option" Changed maximum limit for "VPCHG2" on page 4 from 6.2V to 6.25V for only the "A option" Changed minimum limit for "VRECHG" on page 4 from 7.80V to 7.75V for only the "A option" Changed maximum limit for "VRECHG" on page 4 from 8.20 to 8.25V for only the "A option"
6/30/10	FN6936.0	Initial Release.

Products

Intersil Corporation is a leader in the design and manufacture of high-performance analog semiconductors. The Company's products address some of the industry's fastest growing markets, such as, flat panel displays, cell phones, handheld products, and notebooks. Intersil's product families address power management and analog signal processing functions. Go to www.intersil.com/products for a complete list of Intersil product families.

*For a complete listing of Applications, Related Documentation and Related Parts, please see the respective device information page on intersil.com: [ISL9220, ISL9220A](http://www.intersil.com/products)

To report errors or suggestions for this datasheet, please go to www.intersil.com/askourstaff

FITs are available from our website at <http://rel.intersil.com/reports/search.php>

For additional products, see www.intersil.com/product_tree

Intersil products are manufactured, assembled and tested utilizing ISO9000 quality systems as noted in the quality certifications found at www.intersil.com/design/quality

Intersil products are sold by description only. Intersil Corporation reserves the right to make changes in circuit design, software and/or specifications at any time without notice. Accordingly, the reader is cautioned to verify that data sheets are current before placing orders. Information furnished by Intersil is believed to be accurate and reliable. However, no responsibility is assumed by Intersil or its subsidiaries for its use; nor for any infringements of patents or other rights of third parties which may result from its use. No license is granted by implication or otherwise under any patent or patent rights of Intersil or its subsidiaries.

For information regarding Intersil Corporation and its products, see www.intersil.com

Package Outline Drawing

L20.4x4E

20 LEAD THIN QUAD FLAT NO-LEAD PLASTIC PACKAGE

Rev 0, 4/10

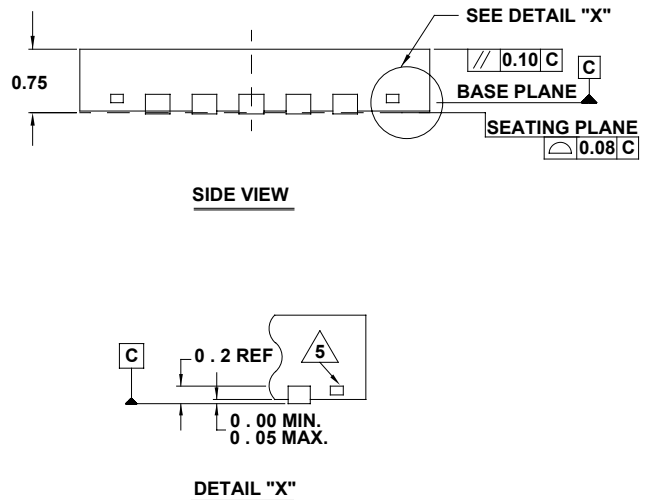
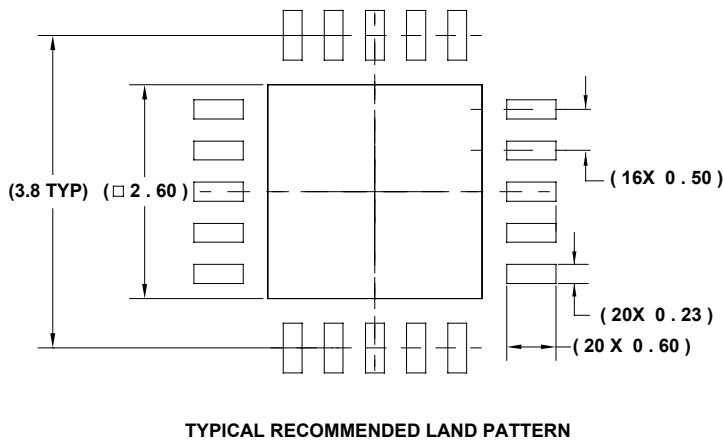
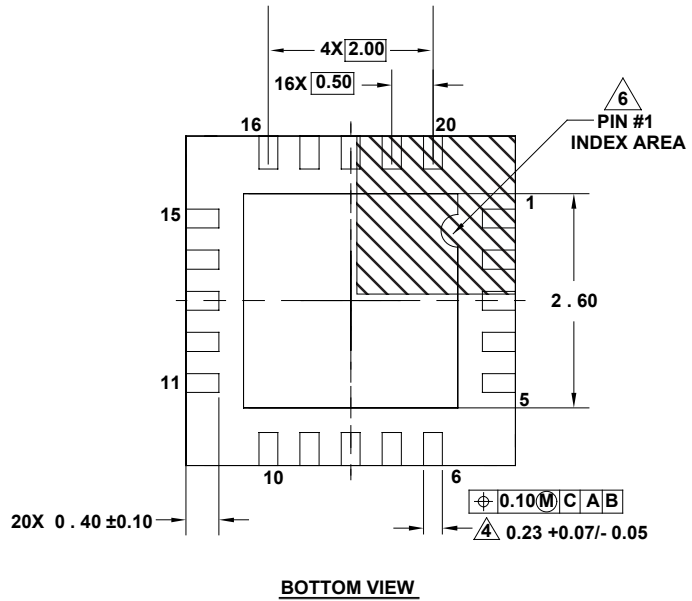
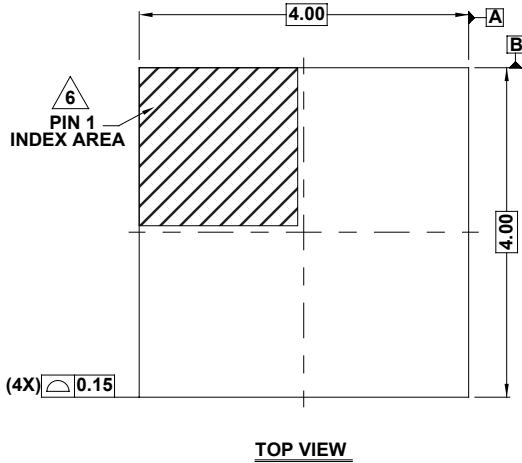

NOTES:

1. Dimensions are in millimeters.
Dimensions in () for Reference Only.
2. Dimensioning and tolerancing conform to ASME Y14.5m-1994.
3. Unless otherwise specified, tolerance : Decimal ± 0.05
4. Dimension applies to the metallized terminal and is measured between 0.15mm and 0.30mm from the terminal tip.
5. Tiebar shown (if present) is a non-functional feature.
6. The configuration of the pin #1 identifier is optional, but must be located within the zone indicated. The pin #1 identifier may be either a mold or mark feature.
7. JEDEC reference drawing: MO-229.