

# SML5050RGB2K-TR

Red/Green/Blue

Surface Mount LED

5.4 × 5.0 × 1.5 mm Chip LED

120° viewing angle

DWG BY:  
PO / GP  
09-14-06

CHK BY:  
PL  
09-15-06

QA:  
\_\_  
09-\_\_-06

MFG:  
\_\_  
\_\_-\_\_-\_\_

REVISION LTR: -  
09-14-06

# 1. SPECIFICATIONS

## (1) Absolute Maximum Ratings

(Ta=25°C)

Parameter	Symbol	MAX.	Unit	
Continuous Forward Current	If	R	20	mA
		G		
		B		
Pulse Forward Current*	Ifp	R	100	mA
		G		
		B		
Power Consumption	Pc	R	55	mW
		G	75	
		B	75	
Electrostatic Discharge	ESD	R	2000	V
		G	150	
		B	150	
Operating Temperature Range	Topr	-40 ~ +85	°C	
Storage Temperature Range	Tstg	-40 ~ +100	°C	
Reverse Voltage	Vr	5	V	
Soldering Temperature	Tslid	Reflow Soldering:240°C /10sec		
		Hand Soldering:350°C /3sec		

\*Duty 1/10 @ 1KHZ

## (2) Electrical / Optical Characteristics

(Ta = 25 °C)

Parameter	Symbol	Min.	Typ.	Max.	Unit	Test Condition	
Forward Voltage*	Vf	R	/	/	2.8	V	If=20mA
		G	/	/	3.8		
		B	/	/	3.8		
Luminous intensity*	Iv	R	280	400	/	mcd	If=20mA
		G	590	900	/		If=20mA
		B	150	250	/		If=20mA
Dominant Wavelength	λ d	R	615	/	635	nm	If=20mA
		G	518	/	532		
		B	460	/	475		
Spectrum Radiation Bandwidth	Δ λ	R	/	20	/	nm	If=20mA
		G	/	35	/		
		B	/	30	/		
Reverse Current	Ir	R	/	/	10	uA	Vr=5V
		G	/	/	10		
		B	/	/	10		
Viewing Angle*	2θ <sub>1/2</sub>	/	120	/	Deg	If=20mA	

- \*Forward voltage measurement allowance is  $\pm 0.1V$ .
- \*Luminous intensity is measured with a light sensor and filter combination that approximates the CIE eye-response curve.
- \*Luminous Intensity Measurement Allowance is  $\pm 10\%$ .
- \*Dominant Wavelength measurement allowance is  $\pm 1nm$ .
- \* $2\theta_{1/2}$  is the off-axis angle at which the luminous intensity is half the axial luminous intensity.
- \*Please see attachments for BIN classifications.

### (3) Typical Electrical / Optical Characteristics Curves

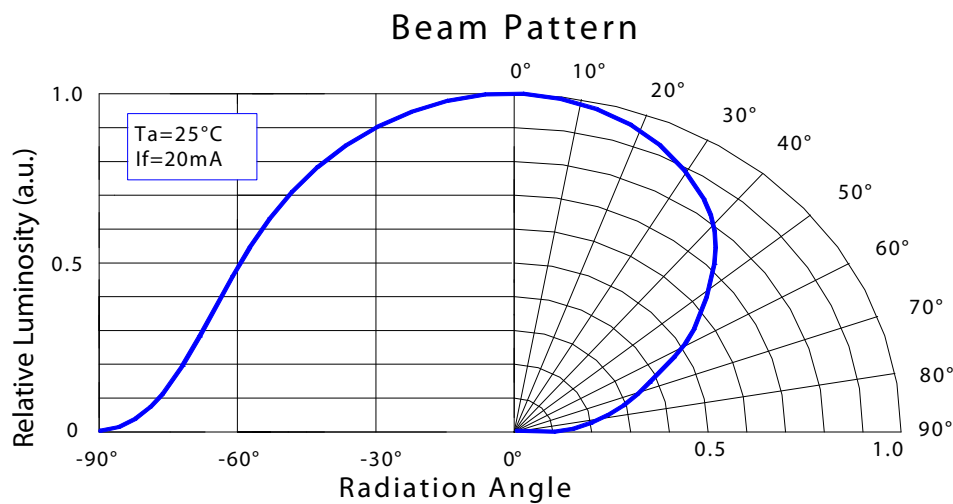
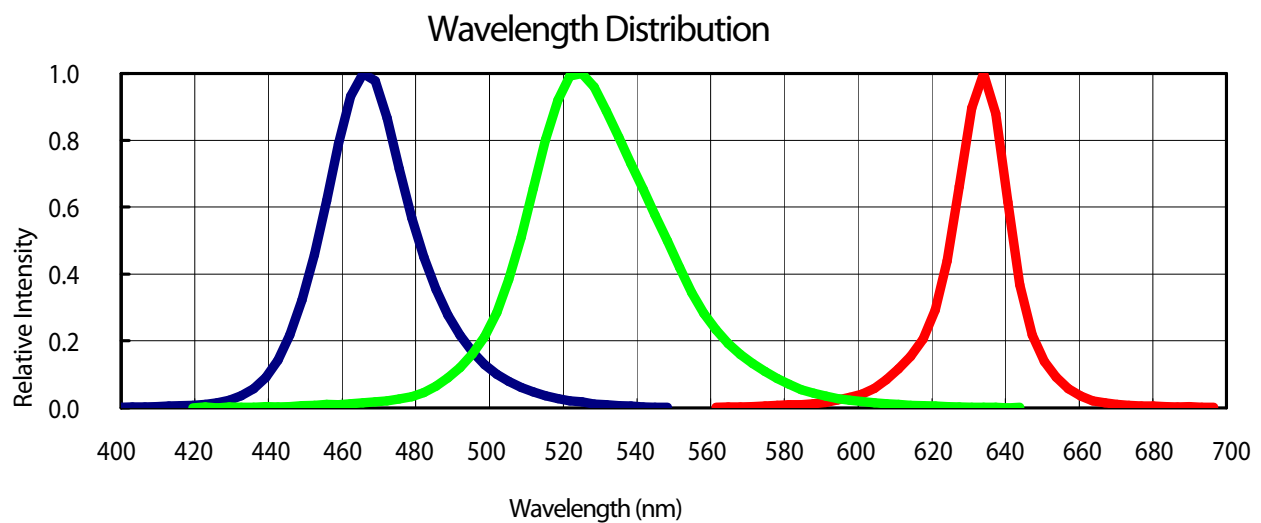

## 2. Package

(1) Outline Dimension (unit= mm)

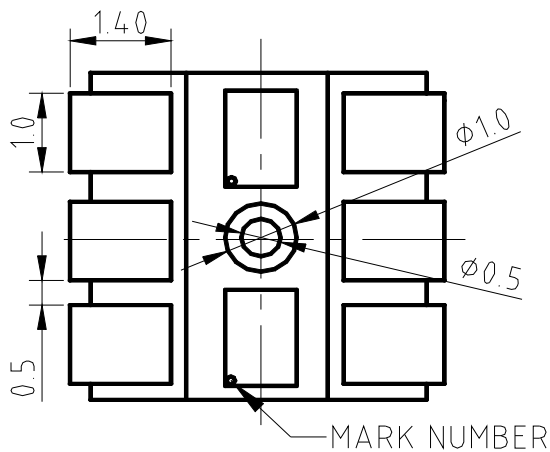
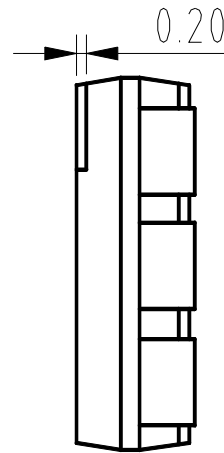
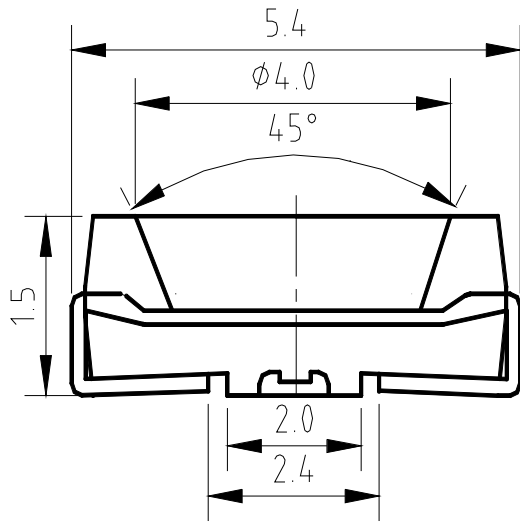
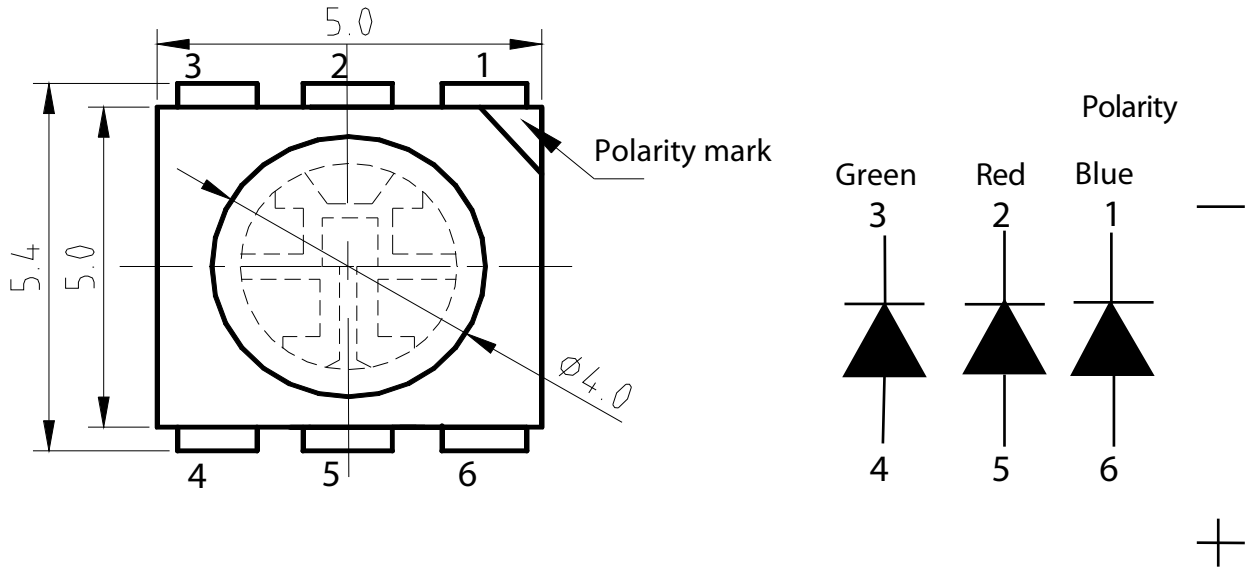

1. All dimensions are in millimeters.
2. Tolerances are  $\pm 0.1$  mm, unless otherwise noted.

Part No.	SML5050RGB2K-TR	DWG NO.	DSTR0163	Page	4 of 6
----------	-----------------	---------	----------	------	--------

**(2) Taping Dimension (unit= mm)**

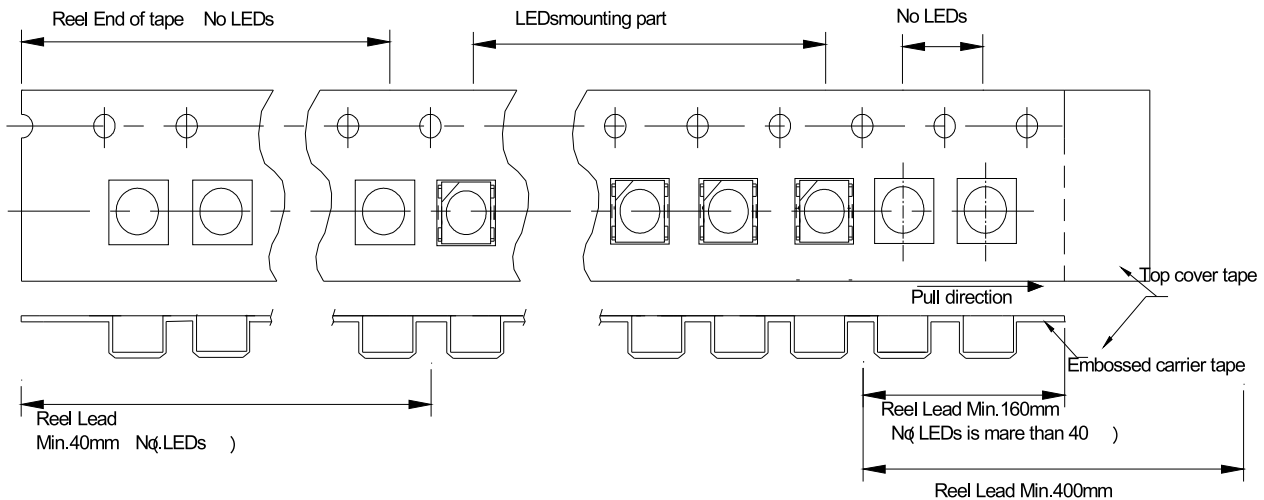
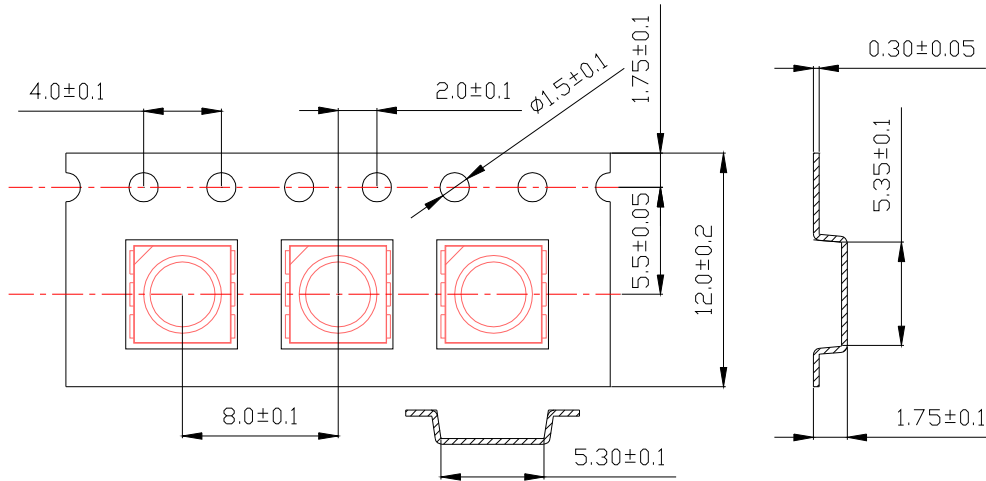
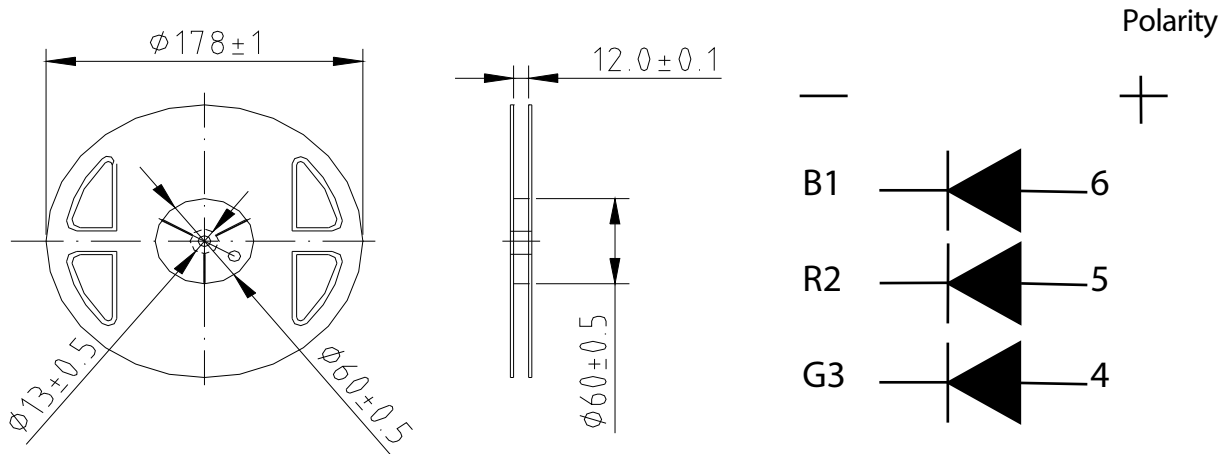

### 3. Handling Precaution

#### (1) Recommended soldering conditions

##### 1.1 Reflow solder temperature profile

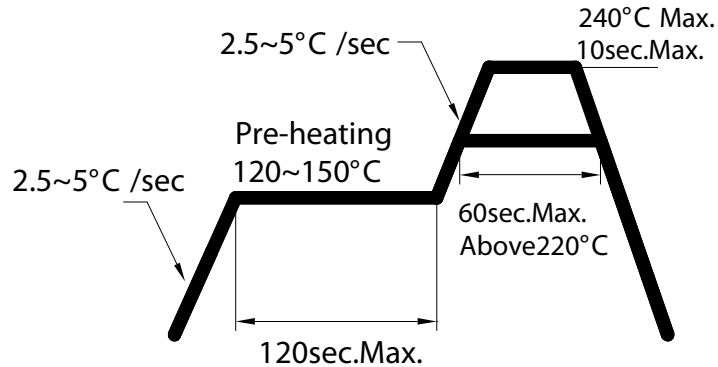

##### 1.2 Recommended Soldering pad design (unit= mm)

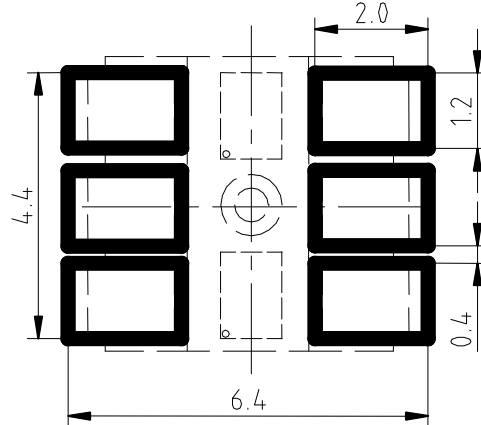

##### 1.3 Soldering conditions

- \* Reflow soldering should not be done more than twice.
- \* When soldering, do not stress on LEDs during heating.
- \* After soldering, do not warp the circuit board.

#### (2) Repairing

- \* Repair should not be done after the LEDs have been soldered. When repair is unavoidable, double-head soldering iron should be used. It should be confirmed beforehand whether the characteristics of the LEDs will be damaged by repair or not.

#### (3) Cleaning

- \* It is recommended to use isopropyl alcohol as a solvent to clean the LEDs. When using other solvents, it should be confirmed beforehand whether the solvents will dissolve the package and the resin or not.

#### (4) Advice on Device Usage

- \* It is recommended that user should complete the use of the whole package within 8 hours upon unsealing. In the event of incomplete usage, it is advised that user preheat the remaining devices at 60°C for 8 hours prior to.