

Ultra-Low Lux, Low Power, Integrated Digital Ambient Light Sensor with Interrupt Function

ISL29033

The ISL29033 is an integrated ambient and infrared light to digital converter with I²C (SMBus Compatible) interface. Its advanced, self-calibrated photodiode array emulates human eye response with excellent IR rejection. The on-chip 16-bit ADC is capable of rejecting 50Hz and 60Hz flicker caused by artificial light sources. The lux range select feature allows users to program the lux range for optimized counts/lux. Power consumption can be reduced to less than 0.3µA when powered down.

The ISL29033 supports a software and hardware interrupt that remains asserted until the host clears it through the I²C interface. The function of ADC conversion continues without stopping after interrupt is asserted.

Designed to operate on supplies from 2.25V to 3.63V with an I²C supply from 1.7V to 3.63V, the ISL29033 is specified for operation over the -40°C to +85°C ambient temperature range.

Related Literature

- See [AN1422](#) "Light Sensor Applications"

Features

- Ambient Light Sensing
- Simple Output Code Directly Proportional to Lux
- Variable Conversion Resolution Up to 16 Bits
- Adjustable Sensitivity Up to 520 Counts Per Lux
- Measurement Range: 0.0019 to 8,000Lux with Four Selectable Ranges
- Program Interrupt Feature
- Light Sensor Close to Human Eye Response
 - Excellent Light Sensor IR and UV Rejection
- 75µA Max Operating Current
 - 0.3µA Max Shutdown Current
- 6 Ld 2.0mmx2.1mmx0.7mm ODFN Package

Applications

- Display and Keypad Dimming Adjustment for:
 - Mobile Devices: Smart Phone, PDA, GPS
 - Computing Devices: Notebook PC, Webpad
 - Consumer Devices: LCD-TV, Digital Picture Frame, Digital Camera
- Industrial and Medical Light Sensing

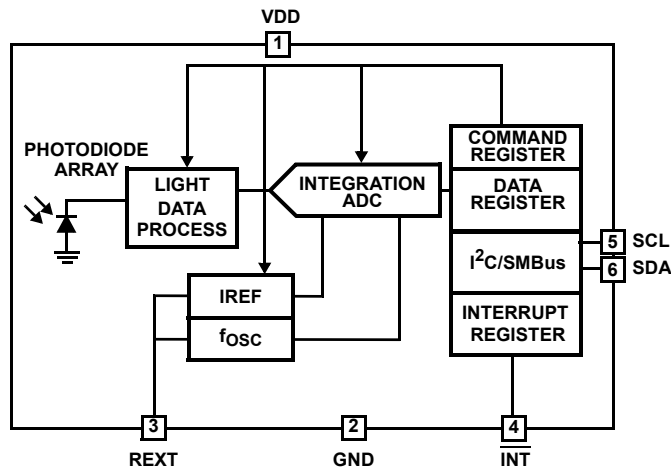
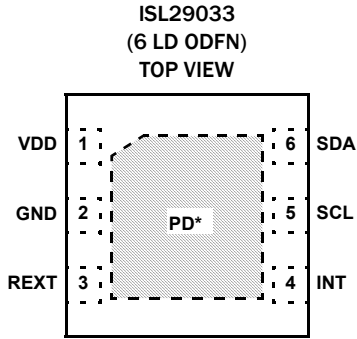

FIGURE 1. BLOCK DIAGRAM

ISL29033

Pin Configuration



*EXPOSED PAD CAN BE CONNECTED TO GND OR ELECTRICALLY ISOLATED

Pin Descriptions

PIN NUMBER	PIN NAME	DESCRIPTION
PD	PD	Thermal Pad (connect to GND, or float)
1	VDD	Positive supply: 2.25V to 3.63V
2	GND	Ground
3	REXT	External resistor pin for ADC reference; connect this pin to ground through a (nominal) 499kΩ resistor.
4	INT	Interrupt pin; low for interrupt alarming. INT pin is open drain. INT remains asserted until the interrupt flag status bit is reset.
5	SCL	I ² C serial clock
6	SDA	I ² C serial data

Ordering Information

PART NUMBER (Notes 1, 2, 3, 4)	TEMP. RANGE (°C)	PACKAGE TAPE AND REEL (Pb-free)	PKG. DWG. #
ISL29033IROZ-T7	-40 to +85	6 Ld ODFN	L6.2x2.1
ISL29033IROZ-EVALZ	Evaluation Board		

NOTES:

1. Please refer to [TB347](#) for details on reel specifications.
2. These Intersil Pb-free plastic packaged products employ special Pb-free material sets; molding compounds/die attach materials and NiPdAu plate - e4 termination finish, which is RoHS compliant and compatible with both SnPb and Pb-free soldering operations. Intersil Pb-free products are MSL classified at Pb-free peak reflow temperatures that meet or exceed the Pb-free requirements of IPC/JEDEC J STD-020.
3. For Moisture Sensitivity Level (MSL), please see device information page for [ISL29033](#). For more information on MSL please see Tech Brief [TB477](#).
4. The part marking is located on the bottom of the part.

ISL29033

Absolute Maximum Ratings (T_A = +25 °C)

V _{DD} Supply Voltage between V _{DD} and GND	4.0V
I ² C Bus Pin Voltage (SCL, SDA)	-0.2V to 4.0V
I ² C Bus Pin Current (SCL, SDA)	<10mA
R _{EXT} Pin Voltage	-0.2V to V _{DD} + 0.5V
INT Pin Voltage	-0.5V to V _{DD} + 0.5V
INT Pin Current	<10mA
ESD Rating	
Human Body Model	2kV

Thermal Information

Thermal Resistance (Typical)	θ _{JA} (°C/W)
6 Ld ODFN (Note 5)	88
Maximum Die Temperature	+90 °C
Storage Temperature	-40 °C to +100 °C
Operating Temperature	-40 °C to +85 °C
Pb-Free Reflow Profile	see link below http://www.intersil.com/pbfree/Pb-FreeReflow.asp

Recommended Operating Conditions

Temperature	-40 °C to +85 °C
Supply Voltage	2.25V to 3.63V

CAUTION: Do not operate at or near the maximum ratings listed for extended periods of time. Exposure to such conditions may adversely impact product reliability and result in failures not covered by warranty.

NOTE:

5. θ_{JA} is measured in free air with the component mounted on a high effective thermal conductivity test board with “direct attach” features. See Tech Brief [TB477](#).

IMPORTANT NOTE: All parameters having Min/Max specifications are guaranteed. Typical values are for information purposes only. Unless otherwise noted, all tests are at the specified temperature and are pulsed tests, therefore: T_J = T_C = T_A

Electrical Specifications V_{DD} = 3.0V, T_A = +25 °C, R_{EXT} = 499kΩ 1% tolerance, 16-bit ADC operation, unless otherwise specified.

PARAMETER	DESCRIPTION	CONDITION	MIN (Note 6)	TYP	MAX (Note 6)	UNIT
V _{DD}	Power Supply Range		2.25		3.63	V
I _{DD}	Supply Current			65	75	μA
I _{DD1}	Supply Current when Powered Down	Software disabled or auto power-down		0.01	0.3	μA
V _{I2C}	Supply Voltage Range for I ² C Interface		1.7		3.63	V
f _{OSC}	Internal Oscillator Frequency		600	670	740	kHz
t _{INT}	ADC Integration/Conversion Time	16-bit ADC data		100		ms
F _{I2C}	I ² C Clock Rate Range			1 to 400		kHz
DATA_0	Count Output when Dark	E = 0 lux, Range 1 (125 lux)		1	5	Counts
DATA_F	Full Scale ADC Code				65535	Counts
ΔDATA DATA	Count Output Variation Over Three Light Sources: Fluorescent, Incandescent and Sunlight	Ambient Light Sensing		±10		%
DATA_1	Light Count Output with LSB of 0.0019 lux/count	E = 37.5 lux, Fluorescent light (Note 7), Ambient light sensing, Range 1 (125 lux)	16000	20000	24000	Counts
DATA_2	Light Count Output with LSB of 0.0075 lux/count	E = 37.5 lux, Fluorescent light (Note 7), Ambient light sensing, Range 2 (500 lux)		5000		Counts
DATA_3	Light Count Output with LSB of 0.03 lux/count	E = 37.5 lux, Fluorescent light (Note 7), Ambient light sensing, Range 3 (2k lux)		1250		Counts
DATA_4	Light Count Output with LSB of 0.12 lux/count	E = 37.5 lux, Fluorescent light (Note 7), Ambient light sensing, Range 4 (8k lux)		312		Counts
DATA_IR1	Infrared Count Output	E = 20 lux Solar light (Note 8), Ambient light sensing, Range 1 (125 lux)	16000	20000	24000	Counts
DATA_IR2	Infrared Count Output	E = 20 lux Solar light (Note 8), Ambient light sensing, Range 2 (500 lux)		5000		Counts

ISL29033

Electrical Specifications $V_{DD} = 3.0V$, $T_A = +25^\circ C$, $R_{EXT} = 499k\Omega$ 1% tolerance, 16-bit ADC operation, unless otherwise specified. (Continued)

PARAMETER	DESCRIPTION	CONDITION	MIN (Note 6)	TYP	MAX (Note 6)	UNIT
DATA_IR3	Infrared Count Output	E = 20 lux Solar light (Note 8), Ambient light sensing, Range 3 (2000 lux)		1250		Counts
DATA_IR4	Infrared Count Output	E = 20 lux Solar light (Note 8), Ambient light sensing, Range 4 (8000 lux)		312		Counts
V _{REF}	Voltage of R _{EXT} Pin			0.52		V
V _{IL}	SCL and SDA Input Low Voltage				0.55	V
V _{IH}	SCL and SDA Input High Voltage		1.25			V
I _{SDA}	SDA Current Sinking Capability	V _{OL} = 0.4V	4	5		mA
I _{INT}	INT Current Sinking Capability	V _{OL} = 0.4V	4	5		mA

Electrical Specifications $V_{DD} = 3.0V$, $T_A = +25^\circ C$, $R_{EXT} = 1M\Omega$ 1% tolerance, 16-bit ADC operation, unless otherwise specified.

PARAMETER	DESCRIPTION	CONDITION	MIN (Note 6)	TYP	MAX (Note 6)	UNIT
V _{DD}	Power Supply Range		2.25		3.63	V
I _{DD}	Supply Current			42	50	μA
I _{DD1}	Supply Current when Powered Down	Software disabled or auto power-down		0.01	0.3	μA
V _{I2C}	Supply Voltage Range for I ² C Interface		1.7		3.63	V
f _{OSC}	Internal Oscillator Frequency		305	340	385	kHz
t _{INT}	ADC Integration/Conversion Time	16-bit ADC data		200		ms
F _{I2C}	I ² C Clock Rate Range			1 to 400		kHz
DATA_0	Count Output when Dark	E = 0 lux, Range 1 (125 lux)		1	10	Counts
DATA_F	Full Scale ADC Code				65535	Counts
Δ DATA DATA	Count Output Variation Over Three Light Sources: Fluorescent, Incandescent and Sunlight	Ambient Light Sensing		± 10		%
DATA_1	Light Count Output with LSB of 0.00095 lux/count	E = 18.75 lux, Fluorescent light (Note 7), Ambient light sensing, Range 1 (62.5 lux)	15000	20000	25000	Counts
DATA_2	Light Count Output with LSB of 0.000375 lux/count	E = 18.75 lux, Fluorescent light (Note 7), Ambient light sensing, Range 2 (250 lux)		5000		Counts
DATA_3	Light Count Output with LSB of 0.015 lux/count	E = 18.75 lux, Fluorescent light (Note 7), Ambient light sensing, Range 3 (1k lux)		1250		Counts
DATA_4	Light Count Output with LSB of 0.6 lux/count	E = 18.75 lux, Fluorescent light (Note 7), Ambient light sensing, Range 4 (4k lux)		312		Counts
DATA_IR1	Infrared Count Output	E = 10 lux Solar light (Note 8), Ambient light sensing, Range 1 (62.5 lux)	15000	20000	25000	Counts
DATA_IR2	Infrared Count Output	E = 10 lux Solar light (Note 8), Ambient light sensing, Range 2 (250 lux)		5000		Counts
DATA_IR3	Infrared Count Output	E = 10 lux Solar light (Note 8), Ambient light sensing, Range 3 (1000 lux)		1250		Counts
DATA_IR4	Infrared Count Output	E = 10 lux Solar light (Note 8), Ambient light sensing, Range 4 (4000 lux)		312		Counts
V _{REF}	Voltage of R _{EXT} Pin			0.52		V

ISL29033

Electrical Specifications $V_{DD} = 3.0V$, $T_A = +25^\circ C$, $R_{EXT} = 1M\Omega$ 1% tolerance, 16-bit ADC operation, unless otherwise specified. (Continued)

PARAMETER	DESCRIPTION	CONDITION	MIN (Note 6)	TYP	MAX (Note 6)	UNIT
V_{IL}	SCL and SDA Input Low Voltage				0.55	V
V_{IH}	SCL and SDA Input High Voltage		1.25			V
I_{SDA}	SDA Current Sinking Capability	$V_{OL} = 0.4V$	4	5		mA
I_{INT}	\overline{INT} Current Sinking Capability	$V_{OL} = 0.4V$	4	5		mA

NOTES:

- Compliance to datasheet limits is assured by one or more methods: production test, characterization and/or design.
- A 550nm green LED is used in production test. The 550nm LED irradiance is calibrated to produce the same DATA count as a fluorescent light with illuminance at the stated lux.
- An 850nm IR LED is used in production test. The 850nm LED irradiance is calibrated to produce the same DATA_IR count as solar light with illuminance at the stated lux.

I²C Electrical Specifications For SCL and SDA (Figure 2), unless otherwise noted, $V_{DD} = 3V$, $T_A = +25^\circ C$, $R_{EXT} = 499k\Omega$ 1% and $1M\Omega$ 1% tolerance.

PARAMETER	DESCRIPTION	CONDITION	MIN (Note 6)	TYP	MAX (Note 6)	UNIT
V_{I2C}	Supply Voltage Range for I ² C Interface		1.7		3.63	V
f_{SCL}	SCL Clock Frequency				400	kHz
V_{IL}	SCL and SDA Input Low Voltage				0.55	V
V_{IH}	SCL and SDA Input High Voltage		1.25			V
V_{hys}	Hysteresis of Schmitt Trigger Input		$0.05V_{DD}$			V
V_{OL}	Low-level Output Voltage (Open-drain) at 4mA Sink Current				0.4	V
I_i	Input Leakage for each SDA, SCL Pin		-10		10	μA
t_{SP}	Pulse Width of Spikes that must be Suppressed by the Input Filter				50	ns
t_{AA}	SCL Falling Edge to SDA Output Data Valid				900	ns
C_i	Capacitance for each SDA and SCL Pin				10	pF
$t_{HD:STA}$	Hold Time (Repeated) START Condition	After this period, the first clock pulse is generated.	600			ns
t_{LOW}	LOW Period of the SCL Clock	Measured at the 30% of V_{DD} crossing	1300			ns
t_{HIGH}	HIGH Period of the SCL Clock		600			ns
$t_{SU:STA}$	Set-up Time for a Repeated START Condition		600			ns
$t_{HD:DAT}$	Data Hold Time		30			ns
$t_{SU:DAT}$	Data Set-up Time		100			ns
t_R	Rise Time of both SDA and SCL Signals	(Note 9)	$20 + 0.1 \times C_b$			ns
t_F	Fall Time of both SDA and SCL Signals	(Note 9)	$20 + 0.1 \times C_b$			ns
$t_{SU:STO}$	Set-up Time for STOP Condition		600			ns
t_{BUF}	Bus Free Time Between a STOP and START Condition		1300			ns
C_b	Capacitive Load for Each Bus Line				400	pF
$R_{pull-up}$	SDA and SCL System Bus Pull-up Resistor	Maximum is determined by t_R and t_F	1			k Ω

I²C Electrical Specifications

For SCL and SDA (Figure 2), unless otherwise noted, V_{DD} = 3V, T_A = +25 °C, R_{EXT} = 499kΩ 1% and 1MΩ 1% tolerance. (Continued)

PARAMETER	DESCRIPTION	CONDITION	MIN (Note 6)	TYP	MAX (Note 6)	UNIT
t _{VD;DAT}	Data Valid Time				0.9	μs
t _{VD;ACK}	Data Valid Acknowledge Time				0.9	μs
V _{nL}	Noise Margin at the LOW Level		0.1V _{DD}			V
V _{nH}	Noise Margin at the HIGH Level		0.2V _{DD}			V

NOTE:

9. C_b is the capacitance of the bus in pF.

Principles of Operation

Photodiodes and ADC

The ISL29033 contains two photodiode arrays that convert light into current. The spectral response for ambient light sensing and infrared (IR) sensing is shown in Figure 8 in the “Typical Performance Curves” section on page 12. After light is converted to current during the light signal process, the current output is converted to digital by a built-in 16-bit Analog-to-Digital Converter (ADC). An I²C command reads the ambient light or IR intensity in counts.

The converter is a charge-balancing integrating type 16-bit ADC. The chosen method for conversion is best for converting small current signals in the presence of an AC periodic noise. A 100ms integration time, for instance, highly rejects 50Hz and 60Hz power line noise simultaneously. See “Integration and Conversion Time” on page 9.

The built-in ADC offers user flexibility in integration time or conversion time. There are two timing modes: Internal Timing Mode and External Timing Mode. In Internal Timing Mode, integration time is determined by an internal oscillator (f_{OSC}) and the n-bit (n = 4, 8, 12, 16) counter inside the ADC. In External Timing Mode, integration time is determined by the time between two consecutive I²C External Timing Mode commands. A good balance of integration time and resolution (depending on application) is required for optimal results.

The ADC has I²C programmable range select to dynamically accommodate various lighting conditions. For very dim conditions, the ADC can be configured at its lowest range (Range 1) in the ambient light sensing.

Low-Power Operation

The ISL29033 initial operation is at the power-down mode after a supply voltage is provided. The data registers contain the default value of 0. When the ISL29033 receives an I²C command to do a one-time measurement from an I²C master, it starts ADC conversion with light sensing. It goes to power-down mode automatically after one conversion is finished and keeps the conversion data available for the master to fetch anytime afterwards. The ISL29033 continuously does ADC conversion with light sensing if it receives an I²C command of continuous measurement. It continuously updates the data registers with the latest conversion data. It goes to power-down mode after it receives the I²C command of power-down.

Ambient Light

There are four operational modes in ISL29033: Programmable ALS once with auto power-down, programmable IR sensing once with auto power-down, programmable continuous ALS sensing, and programmable continuous IR sensing. These four modes can be programmed in series to fulfill the application needs. The detailed program configuration is shown in “BLOCK DIAGRAM” on page 1.

When the part is programmed for ambient light sensing, the ambient light with wavelength within the “Ambient Light Sensing” spectral response curve in Figure 8 is converted into current. With ADC, the current is converted to an unsigned n-bit (up to 16 bits) digital output.

When the part is programmed for infrared (IR) sensing, the IR light with wavelength within the “IR Sensing” spectral response curve in Figure 8 is converted into current. With ADC, the current is converted to an unsigned n-bit (up to 16 bits) digital output.

Interrupt Function

The active low interrupt pin is an open drain pull-down configuration. The interrupt pin serves as an alarm or monitoring function to determine whether the ambient light level exceeds the upper threshold or goes below the lower threshold. Note that the function of ADC conversion continues without stopping after interrupt is asserted. If the user needs to read the ADC count that triggers the interrupt, reading should be done before the data registers are refreshed by subsequent conversions. The user can also configure the persistency of the interrupt pin. This reduces the possibility of false triggers, such as noise or sudden spikes in ambient light conditions. An unexpected camera flash, for example, can be ignored by setting the persistency to eight integration cycles.

ALS Ranges Considerations

When measuring ALS counts higher than 30000 counts on Range 1 of the 16-bit ADC, switch to Range 2 (change [1 to 0] bits of Register 1 from 00 to 01), and re-measure the ALS counts and other data to change to Range 3 and Range 4. This recommendation pertains only to applications in which light incident on the sensor is IR-heavy and is distorted by tinted glass that increases the ratio of infrared to visible light.

V_{DD} Power-up and Power Supply Considerations

Upon power-up, ensure a V_{DD} slew rate of 0.5V/ms or greater. After power-up, or if the power supply temporarily deviates from

ISL29033

specification (2.25V to 3.63V), the following step is recommended: write 0x00 to register 0x00. Wait a few seconds, and then rewrite all registers to the desired values. A hardware reset method can be used, if preferred, instead of writing to the test registers. For this method, set $V_{DD} = 0V$ for 1 second or more, power backup at the required slew rate, and write the registers to the desired values.

Power-Down

To put the ISL29033 into a power-down state, the user can set [7 to 5] bits to 0 in Register 0. Or more simply, set all of Register 0 to 0x00.

I²C Interface

There are eight 8-bit registers available inside the ISL29033. The two command registers define the operation of the device. The command registers do not change until the registers are overwritten. The two 8-bit data read-only registers are for the ADC output. The data registers contain the ADC's latest digital output,

or the number of clock cycles in the previous integration period (Figure 2).

The ISL29033 I²C interface slave address is internally hard-wired as 1000100. When 1000100x, with x as R or \bar{W} , is sent after the Start condition, the device compares the first 7 bits of this byte to its address, and matches. Figure 3 shows a sample one-byte read, and Figure 4 shows a sample one-byte write. The I²C bus master always drives the SCL (clock) line, while either the master or the slave can drive the SDA (data) line. Every I²C transaction begins with the master asserting a start condition (SDA falling while SCL remains high). The following byte is driven by the master and includes the slave address and the read/write bit. The receiving device is responsible for pulling SDA low during the acknowledgement period. Every I²C transaction ends with the master asserting a stop condition (SDA rising while SCL remains high).

For more information about the I²C standard, please consult the Philips™ I²C specification documents.

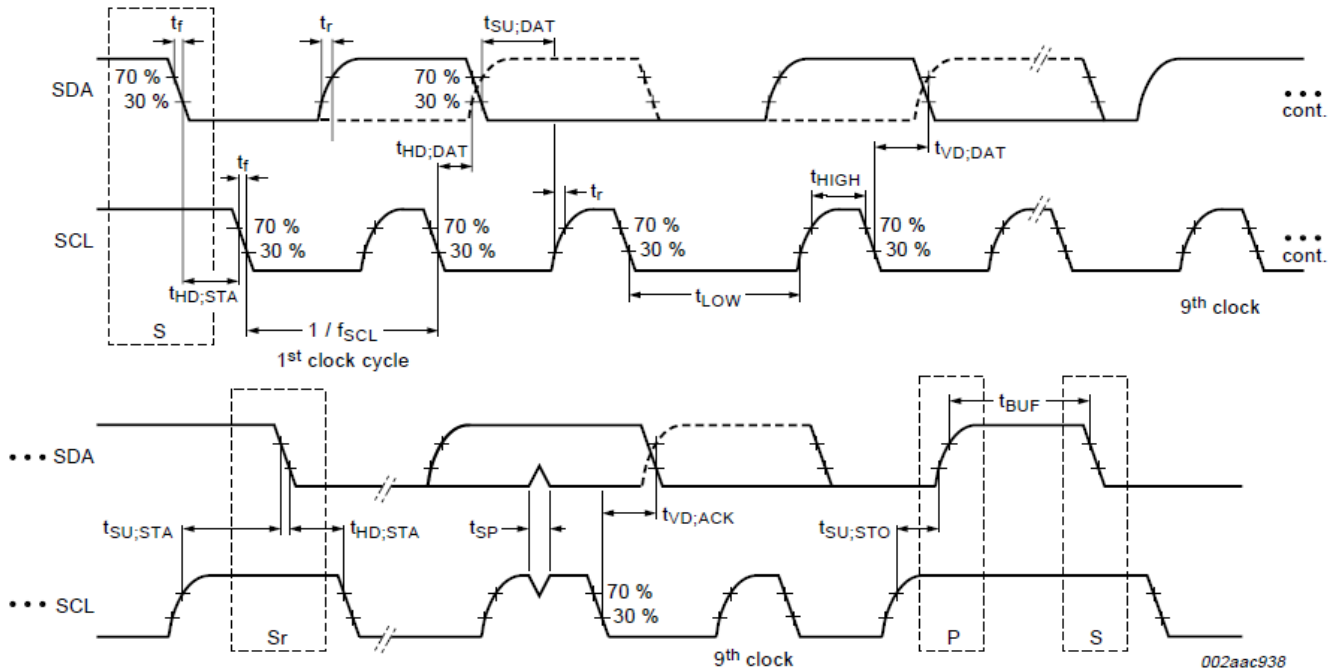

FIGURE 2. I²C TIMING DIAGRAM

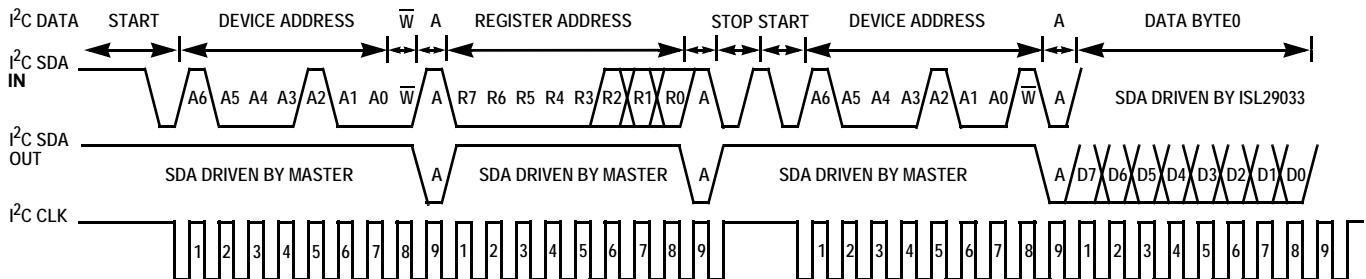

FIGURE 3. I²C READ TIMING DIAGRAM SAMPLE

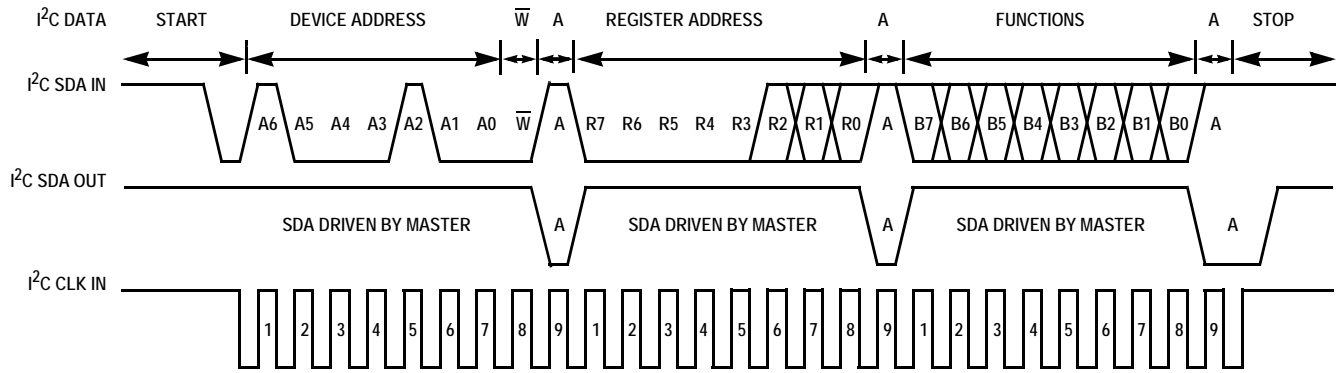

FIGURE 4. I²C WRITE TIMING DIAGRAM SAMPLE

TABLE 1. REGISTER SET

ADDR	REG NAME	BIT								DEFAULT
		7	6	5	4	3	2	1	0	
00h	COMMANDI	OP2	OP1	OP0	0	0	FLAG	PRST1	PRST0	00h
01h	COMMANDII	0	0	0	0	RES1	RES0	RANGE1	RANGE0	00h
02h	DATA _{LSB}	D7	D6	D5	D4	D3	D2	D1	D0	00h
03h	DATA _{MSB}	D15	D14	D13	D12	D11	D10	D9	D8	00h
04h	INT_LT_LSB	TL7	TL6	TL5	TL4	TL3	TL2	TL1	TL0	00h
05h	INT_LT_MSB	TL15	TL14	TL13	TL12	TL11	TL10	TL9	TL8	00h
06h	INT_HT_LSB	TH7	TH6	TH5	TH4	TH3	TH2	TH1	TH0	FFh
07h	INT_HT_MSB	TH15	TH14	TH13	TH12	TH11	TH10	TH9	TH8	FFh

Register Set

There are eight registers available in the ISL29033. Table 1 summarizes their functions.

Command Register I 00 (Hex)

The first command register has the following functions:

1. Operation Mode: Bits 7, 6, and 5. These three bits determine the operation mode of the device (Table 2). Interrupt flag: Bit 2. This is the status bit of the interrupt (Table 3). The bit is set to logic high when the interrupt thresholds have been triggered (out of threshold window), and to logic low when not yet triggered. When activated and the interrupt is triggered, the $\overline{\text{INT}}$ pin goes low, and the interrupt status bit goes high until the status bit is polled through the I²C read command. Both the $\overline{\text{INT}}$ output and the interrupt status bit are automatically cleared at the end of the 8-bit (00h) command register transfer.

TABLE 2. OPERATION MODE

BITS 7 TO 5	OPERATION
000	Power-down the device
001	Reserved (Do not use)
010	Reserved (Do not use)
100	Reserved (Do not use)
101	ALS continuous
110	IR continuous
111	Reserved (Do not use)

TABLE 3. INTERRUPT FLAG

BIT 2	OPERATION
0	Interrupt is cleared or not triggered yet
1	Interrupt is triggered

2. **Interrupt Persist:** Bits 1 and 0. The interrupt pin and the interrupt flag are triggered or set when the data sensor reading is out of the interrupt threshold window after *m* consecutive number of integration cycles (Table 4). The interrupt persist bits determine *m*.

TABLE 4. INTERRUPT PERSIST

BIT 1:0	NUMBER OF INTEGRATION CYCLES
00	1
01	4
10	8
11	16

Command Register II 01 (Hex)

The second command register has the following functions:

- Resolution:** Bits 3 and 2. Bits 3 and 2 determine the ADC resolution and the number of clock cycles per conversion (Table 5). Changing the number of clock cycles does more than just change the resolution of the device; it also changes the integration time, which is the period during which the analog-to-digital (A/D) converter samples the photodiode current signal for a measurement.

TABLE 5. ADC RESOLUTION DATA WIDTH

BITS 3:2	NUMBER OF CLOCK CYCLES	n-BIT ADC
00	$2^{16} = 65,536$	16
01	$2^{12} = 4,096$	12
10	$2^8 = 256$	8
11	$2^4 = 16$	4

- Range:** Bits 1 and 0. The Full Scale Range (FSR) can be adjusted through the I²C by using Bits 1 and 0. Table 6 lists the possible values of FSR for the 499kΩ R_{EXT} resistor.

TABLE 6. RANGE/FSR LUX

BITS 1:0	k	RANGE(k)	FSR (LUX) @ ALS SENSING
00	1	Range1	125
01	2	Range2	500
10	3	Range3	2,000
11	4	Range4	8,000

Data Registers (02 Hex and 03 Hex)

The device has two 8-bit read-only registers to hold the data from LSB to MSB for the ADC (Table 7). The most significant bit (MSB) is accessed at 03 hex, and the least significant bit (LSB) is accessed at 02 hex. For 16-bit resolution, the data is from D0 to D15; for 12-bit resolution, the data is from D0 to D11; for 8-bit resolution, the data is from D0 to D7. The registers are refreshed after every conversion cycle.

TABLE 7. DATA REGISTERS

ADDRESS (HEX)	CONTENTS
02	D0 is LSB for 4-, 8-, 12- or 16-bit resolution; D3 is MSB for 4-bit resolution; D7 is MSB for 8-bit resolution
03	D15 is MSB for 16-bit resolution; D11 is MSB for 12-bit resolution

Interrupt Registers (04, 05, 06 and 07 Hex)

Registers 04 and 05 hex set the low (LO) threshold for the interrupt pin and the interrupt flag. Register 04 hex is the LSB, and Register 05 hex is the MSB. By default, the interrupt threshold LO is 00 hex for both LSB and MSB.

Registers 06 and 07 hex set the high (HI) threshold for the interrupt pin and the interrupt flag. Register 06 hex is the LSB, and Register 07 hex is the MSB. By default, the interrupt threshold HI is FF hex for both LSB and MSB.

Calculating Lux

The ISL29033 ADC output codes, DATA, are directly proportional to lux in ambient light sensing, as shown in Equation 1.

$$E_{cal} = \alpha \times \text{DATA} \quad (\text{EQ. 1})$$

In this equation, E_{cal} is the calculated lux reading. The constant, α , is determined by the full scale range and the ADC maximum output counts. The constant is independent of the light sources (fluorescent, incandescent and sunlight) because the light source IR component is removed during the light signal process. The constant can also be viewed as the sensitivity (the smallest lux measurement the device can measure), as shown in Equation 2.

$$\alpha = \frac{\text{Range}(k)}{\text{Count}_{max}} \quad (\text{EQ. 2})$$

In this equation, Range(k) is as defined in Table 6. Count_{max} is the maximum output counts from the ADC.

The transfer function used for n-bits ADC is as shown in Equation 3:

$$E_{cal} = \frac{\text{Range}(k)}{2^n} \times \text{DATA} \quad (\text{EQ. 3})$$

In this equation, $n = 4, 8, 12$ or 16 and is the number of ADC bits programmed in the command register. The number 2^n represents the maximum number of counts possible from the ADC output. Data is the ADC output stored in data Registers 02 hex and 03 hex.

Integration and Conversion Time

ADC resolution and f_{OSC} determine the integration time, t_{int} , as shown in Equation 4.

$$t_{int} = 2^n \times \frac{1}{f_{OSC}} = 2^n \times \frac{R_{EXT}}{655\text{kHz} \times 499\text{k}\Omega} \quad (\text{EQ. 4})$$

In this equation, n is the number of bits of resolution, and $n = 4, 8, 12$ or 16 . Therefore, 2^n is the number of clock cycles. The value of n can be programmed at the command register, Register 01 (hex), Bits 3 and 2 (Table 8).

TABLE 8. INTEGRATION TIME OF n-BIT ADC

R _{EXT} (kΩ)	n = 16-BIT (ms)	n = 12-BIT (ms)	n = 8-BIT (μs)	n = 4-BIT (μs)
499	100	6.25	391	24
1000	200	12.5	782	48

External Scaling Resistor R_{EXT} for f_{OSC} and Range

The ISL29033 uses an external resistor, R_{EXT}, to fix its internal oscillator frequency, f_{OSC}, and the light sensing range, Range. The f_{OSC} and Range are inversely proportional to R_{EXT}. For ease of use, the proportionality constant is referenced to 499kΩ. Calculation for Range is shown in Equation 5 and for f_{OSC} in Equation 6.

$$\text{Range} = \frac{499\text{k}\Omega}{R_{\text{EXT}}} \times \text{Range}(k) \quad (\text{EQ. 5})$$

$$f_{\text{OSC}} = \frac{499\text{k}\Omega}{R_{\text{EXT}}} \times 655\text{kHz} \quad (\text{EQ. 6})$$

Noise Rejection

In general, integrating-type ADCs have excellent noise rejection characteristics for periodic noise sources for which frequency is an integer multiple of the conversion rate. For example, a 60Hz AC unwanted signal's sum from 0ms to k*16.66ms (k = 1,2...k_i) is zero. Similarly, setting the device's integration time to be an integer multiple of the periodic noise signal greatly improves the light sensor output signal in the presence of noise.

ADC Output in IR Sensing

The ISL29033 ADC output codes, DATA, are directly proportional to the IR intensity received in IR sensing, as shown in Equation 7.

$$\text{DATA}_{\text{IR}} = \beta \times E_{\text{IR}} \quad (\text{EQ. 7})$$

In this equation, E_{IR} is the received IR intensity. The constant, β, changes with the spectrum of background IR noise, such as

sunlight and incandescent light. The constant, β, also changes with ADC range and resolution selections.

Suggested PCB Footprint

It is important that users check [Tech Brief 477, "Surface Mount Assembly Guidelines for Optical Dual FlatPack No Lead \(ODFN\) Package"](#) before starting ODFN product board mounting:

<http://www.intersil.com/data/tb/TB477.pdf>

Layout Considerations

The ISL29033 is relatively insensitive to layout. Like other I²C devices, it is intended to provide excellent performance even in significantly noisy environments. Attention to a few considerations will ensure best performance.

Route the supply and I²C traces as far as possible from all sources of noise. Use two power-supply decoupling capacitors, 1μF and 0.1μF, placed close to the device.

Typical Circuit

A typical application for the ISL29033 is shown in Figure 5. The ISL29033 I²C address is internally hardwired as 1000100. The device can be tied onto a system's I²C bus together with other I²C compliant devices.

Soldering Considerations

Convection heating is recommended for reflow soldering; direct-infrared heating is not recommended. The plastic ODFN package does not require a custom reflow soldering profile; it is qualified to +260 °C. A standard reflow soldering profile with a +260 °C maximum is recommended.

ALS Sensor Window Layout

Special care should be taken to ensure that the sensor, as shown in the sensor location outline (Figure 6), is uniformly illuminated. Shadows from off-angle window openings can affect uniform illumination, which in turn can affect measurement results.

ISL29033

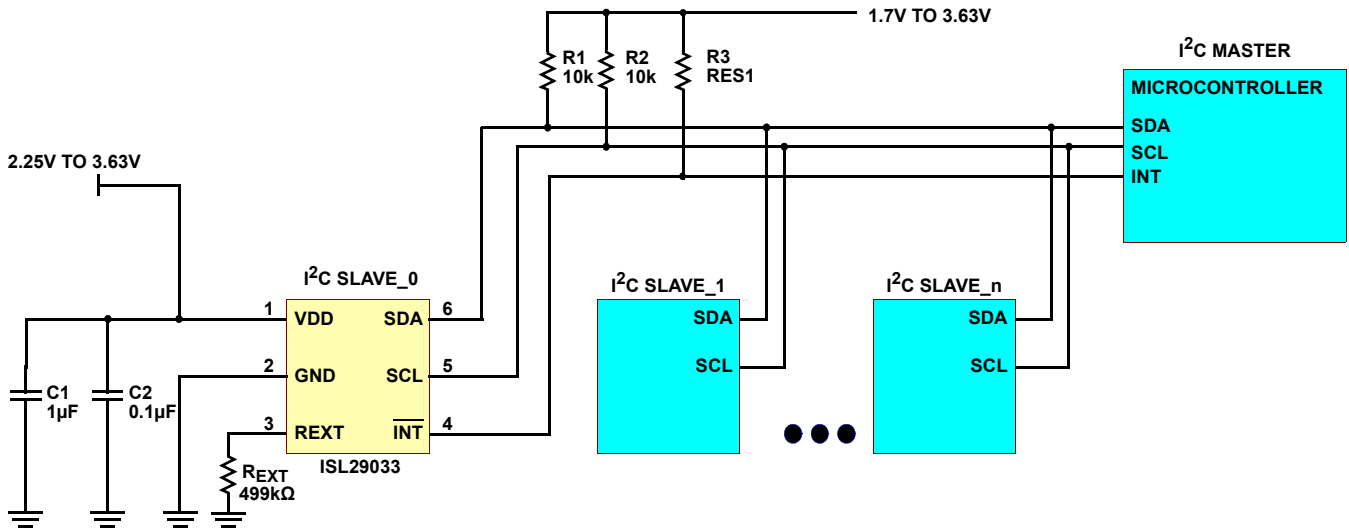

FIGURE 5. ISL29033 TYPICAL CIRCUIT

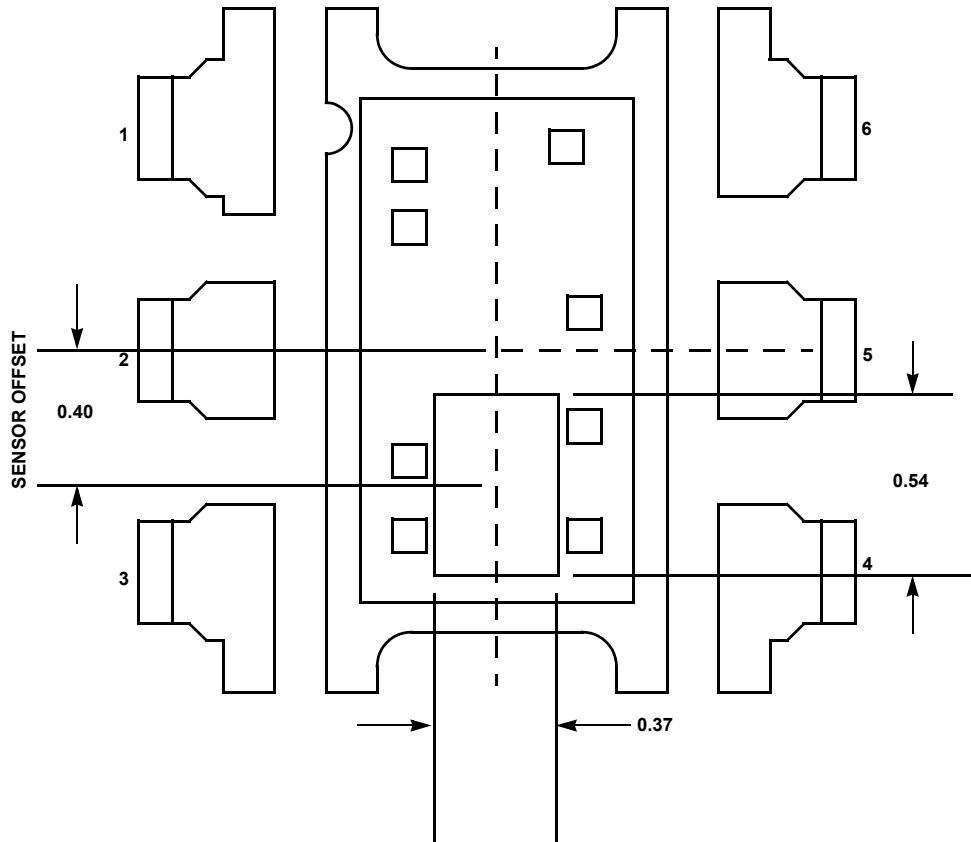

FIGURE 6. 6 LD ODFN SENSOR LOCATION OUTLINE

Typical Performance Curves $V_{DD} = 3.0V, R_{EXT} = 499k\Omega$

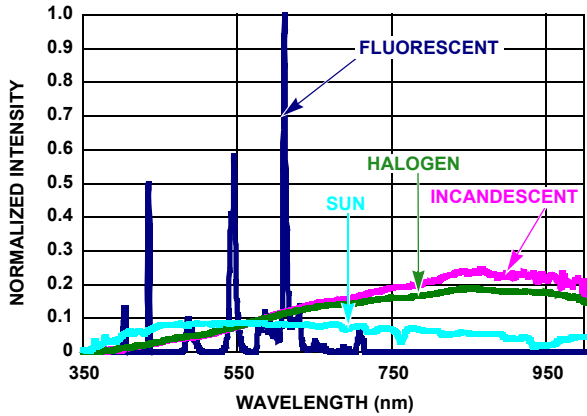

FIGURE 7. SPECTRUM OF FOUR LIGHT SOURCES NORMALIZED BY LUMINOUS INTENSITY (LUX)

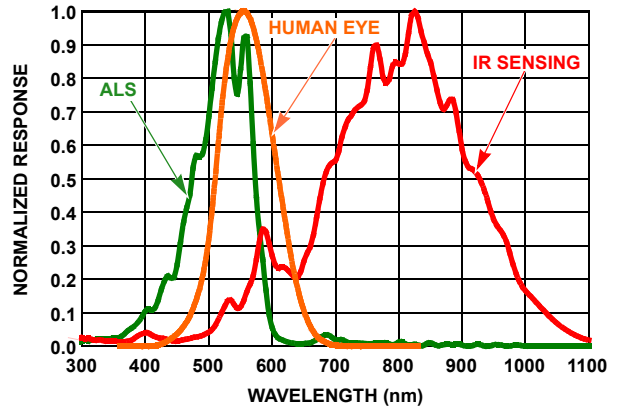

FIGURE 8. NORMALIZED SPECTRAL RESPONSE FOR AMBIENT LIGHT SENSING

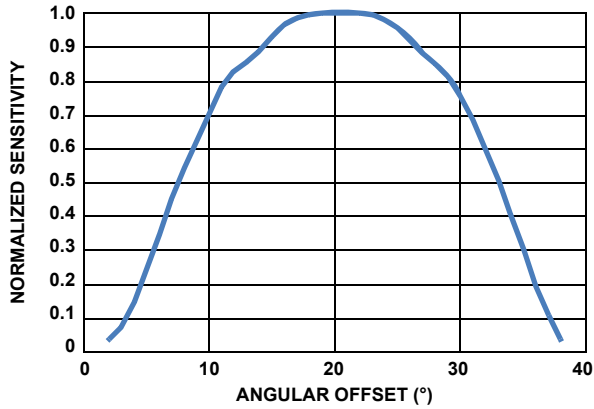

FIGURE 9. ANGULAR SENSITIVITY

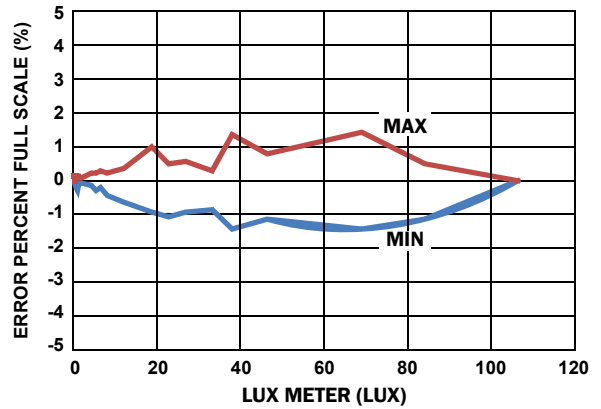

FIGURE 10. LINEARITY OVER RANGE 1

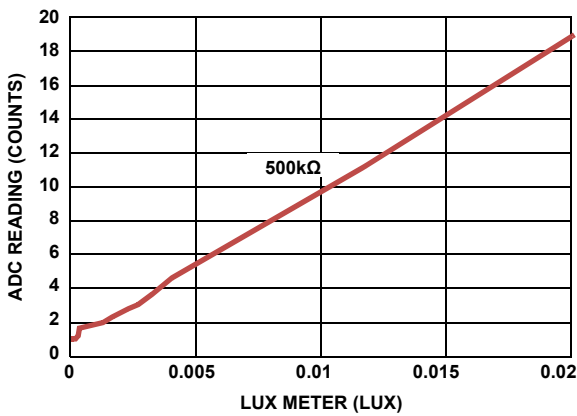

FIGURE 11. LOW LUX AT GREEN LED (500kΩ)

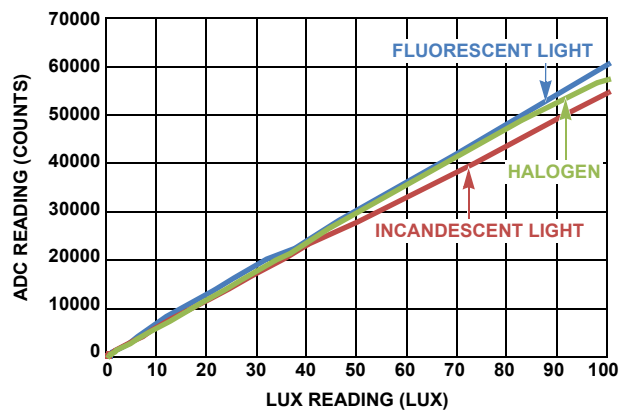

FIGURE 12. LIGHT SOURCES AT RANGE 1, 500kΩ R_{EXT}

Typical Performance Curves $V_{DD} = 3.0V, R_{EXT} = 499k\Omega$ (Continued)

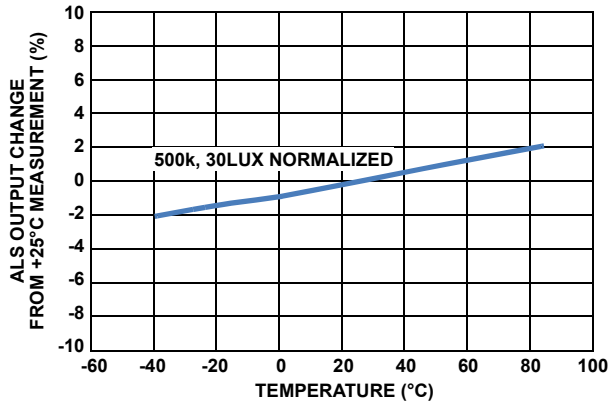

FIGURE 13. 500kΩ ALS COUNT, 30 LUX NORMALIZED

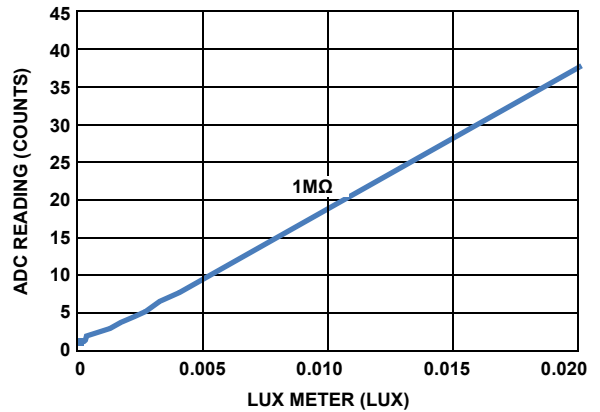

FIGURE 14. LOW LUX AT GREEN LED (1MΩ)

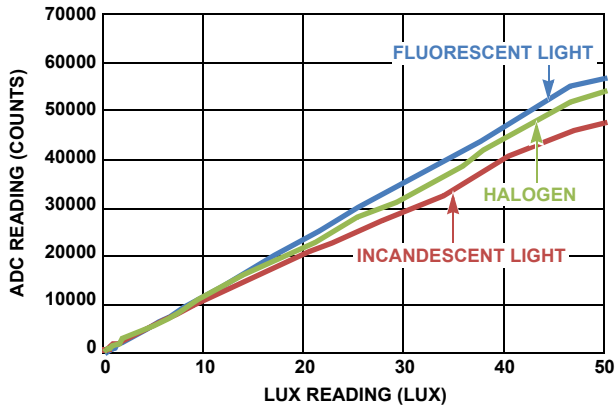

FIGURE 15. LIGHT SOURCES AT RANGE 1, 1MΩ R_{EXT}

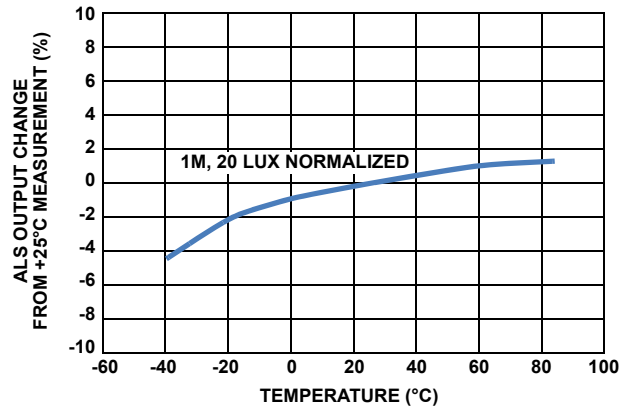

FIGURE 16. 1MΩ ALS COUNTS, 30 LUX NORMALIZED

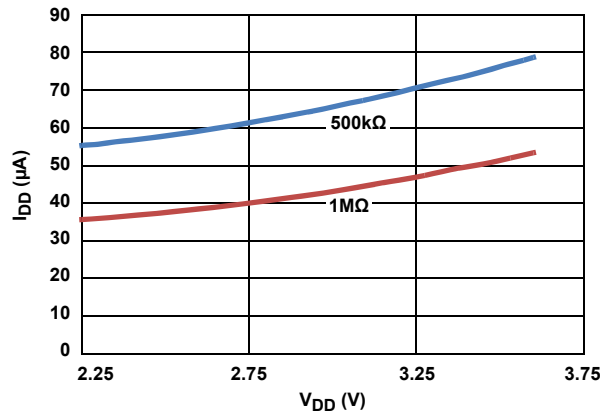

FIGURE 17. SUPPLY CURRENT vs V_{DD} ALS SENSING

ISL29033

Revision History

The revision history provided is for informational purposes only and is believed to be accurate, but not warranted. Please go to web to make sure you have the latest Rev.

DATE	REVISION	CHANGE
9/21/2011	FN7656.1	Changed Title on page 1 from "Integrated Digital Ambient Light Sensor with Interrupt Function" to "Ultra-Low Lux, Low Power, Integrated Digital Ambient Light Sensor with Interrupt Function"
8/25/2011	FN7656.0	Initial Release

Products

Intersil Corporation is a leader in the design and manufacture of high-performance analog semiconductors. The Company's products address some of the industry's fastest growing markets, such as, flat panel displays, cell phones, handheld products, and notebooks. Intersil's product families address power management and analog signal processing functions. Go to www.intersil.com/products for a complete list of Intersil product families.

For a complete listing of Applications, Related Documentation and Related Parts, please see the respective device information page on intersil.com: [ISL29033](http://intersil.com)

To report errors or suggestions for this datasheet, please go to www.intersil.com/askourstaff

FITs are available from our website at <http://rel.intersil.com/reports/search.php>

For additional products, see www.intersil.com/product_tree

Intersil products are manufactured, assembled and tested utilizing ISO9000 quality systems as noted in the quality certifications found at www.intersil.com/design/quality

Intersil products are sold by description only. Intersil Corporation reserves the right to make changes in circuit design, software and/or specifications at any time without notice. Accordingly, the reader is cautioned to verify that data sheets are current before placing orders. Information furnished by Intersil is believed to be accurate and reliable. However, no responsibility is assumed by Intersil or its subsidiaries for its use; nor for any infringements of patents or other rights of third parties which may result from its use. No license is granted by implication or otherwise under any patent or patent rights of Intersil or its subsidiaries.

For information regarding Intersil Corporation and its products, see www.intersil.com

Package Outline Drawing

L6.2x2.1

6 LEAD OPTICAL DUAL FLAT NO-LEAD PLASTIC PACKAGE (ODFN)

Rev 3, 5/11

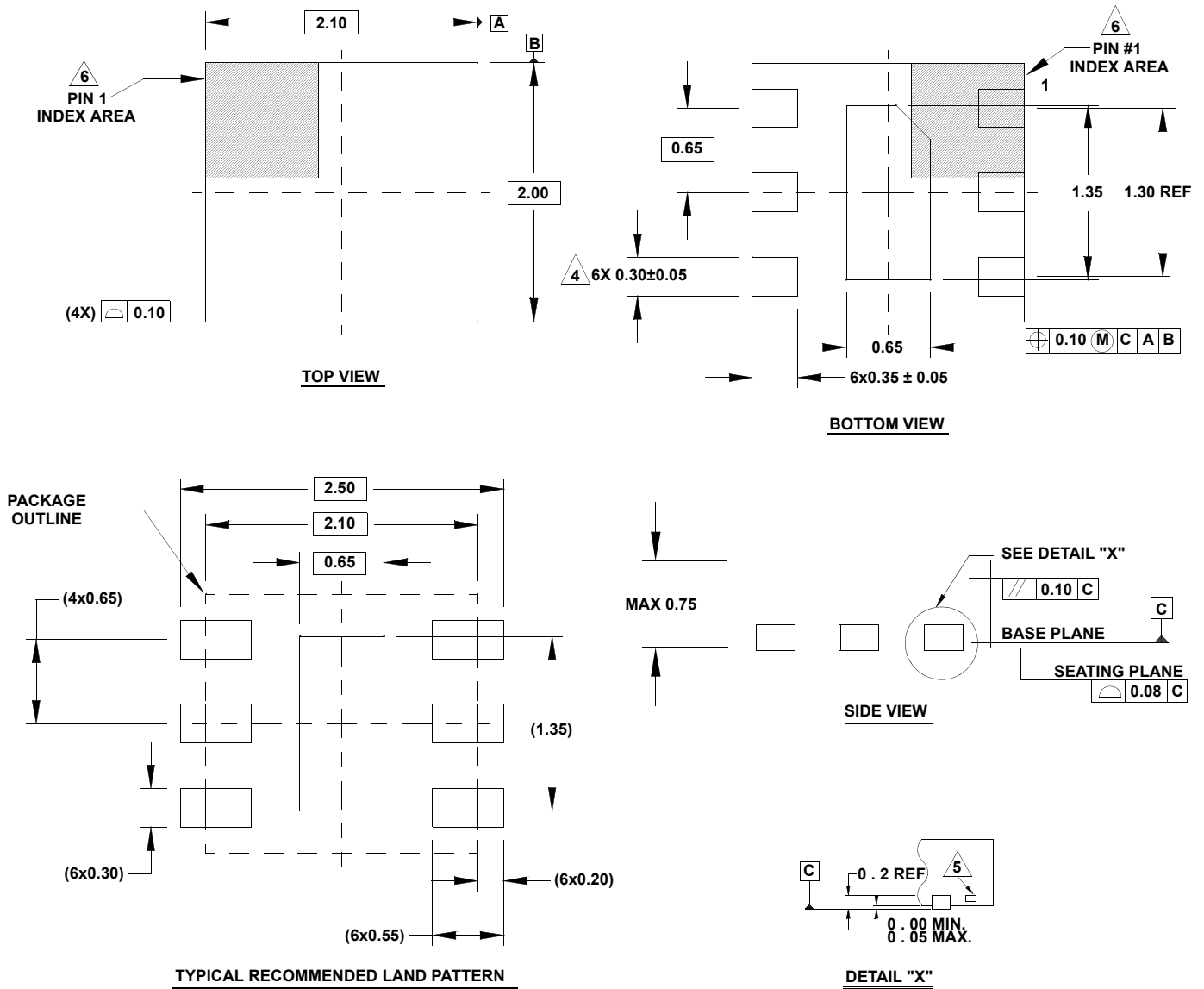

NOTES:

- Dimensions are in millimeters.
Dimensions in () for Reference Only.
- Dimensioning and tolerancing conform to ASME Y14.5m-1994.
- Unless otherwise specified, tolerance : Decimal ± 0.05
- Dimension applies to the metallized terminal and is measured between 0.15mm and 0.30mm from the terminal tip.
- Tiebar shown (if present) is a non-functional feature.
- The configuration of the pin #1 identifier is optional, but must be located within the zone indicated. The pin #1 identifier may be either a mold or mark feature.