

Wireless LAN Integrated Medium Access Controller with Baseband Processor



The Intersil ISL3873 Wireless LAN Integrated Medium Access Controller with Integrated Baseband Processor is part of the PRISM® 2.4GHz radio

chip set. The ISL3873 directly interfaces with the Intersil's IF QMODEM (HFA3783). Adding Intersil's RF/IF Converter (ISL3685) and Intersil's Power Amp (HFA3983) offers the designer a complete end-to-end WLAN Chip Set solution. Protocol and PHY support are implemented in firmware thus, supporting customization of the WLAN solution.

Firmware implements the full IEEE 802.11 Wireless LAN MAC protocol. It supports BSS and IBSS operation under DCF, and operation under the optional Point Coordination Function (PCF). Low level protocol functions such as RTS/CTS generation and acknowledgment, fragmentation and de-fragmentation, and automatic beacon monitoring are handled without host intervention. Active scanning is performed autonomously once initiated by host command. Host interface command and status handshakes allow concurrent operations from multi-threaded I/O drivers. Additional firmware functions specific to access point applications are also available.

The ISL3873 has on-board A/Ds and D/A for analog I and Q inputs and outputs, for which the HFA3783 IF QMODEM is recommended. Differential phase shift keying modulation schemes DBPSK and DQPSK, with data scrambling capability, are available along with Complementary Code Keying to provide a variety of data rates. Both Receive and Transmit AGC functions with 7-bit AGC control obtain maximum performance in the analog portions of the transceiver.

Built-in flexibility allows the ISL3873 to be configured through a general purpose control bus, for a range of applications. The ISL3873 is housed in a thin plastic BGA package suitable for PCMCIA board applications.

The ISL3873 is designed to provide maximum performance with minimum power consumption. External pin layout is organized to provide optimal PC board layout to all user interfaces including PCMCIA and USB.

Ordering Information

PART NUMBER	TEMP. RANGE (°C)	PACKAGE	PART NUMBER
ISL3873IK	-40 to 85	192 BGA	V192.14x14
ISL3873IK96	-40 to 85	Tape and Reel	1000 Units /Reel

New Features of the ISL3873

- USB Host Interface Supports USB V1.1 at 12Mbps.
- New Start Up Modes Allow the PCMCIA Card Information Structure to be Initialized From a Serial EEPROM. This Allows Firmware to be Downloaded from the Host, Eliminating the Parallel Flash Memory Device
- Firmware Can be Loaded from Serial Flash Memory
- Zero Glue Connection to 16-Bit Wide SRAM Devices
- Low Frequency Crystal Oscillator to Maintain Time and Allow Baseband Clock Source to Power off During Sleep Mode
- Improved Performance of Internal WEP Engine
- Improvements to Debug Mode Support Tracing Execution From on Chip Memory
- Programmable MBUS Cycle Extension Allows Accessing of Slow Memory Devices Without Slowing the Clock
- Complete DSSS Baseband Processor
- RAKE Receiver with Decision Feedback Equalizer
- Processing Gain FCC Compliant
- Programmable Data Rate. 1, 2, 5.5, and 11Mbps
- Ultra Small Package. 14 x 14mm
- Single Supply Operation. 2.7V to 3.6V
- Modulation Methods. DBPSK, DQPSK, and CCK
- Supports Full or Half Duplex Operations
- On-Chip A/D and D/A Converters for I/Q Data (6-Bit, 22MSPS), AGC, and Adaptive Power Control (7-Bit)
- Targeted for Multipath Delay Spreads 125ns at 11Mbps, 250ns at 5.5Mbps
- Supports Short Preamble and Antenna Diversity

Applications

- PC Card Wireless LAN Adapters
- USB PCMCIA Wireless LAN Adapters
- PCN / Wireless PBX / Wireless Local Loop
- High Data Rate Wireless LAN Systems Targeting IEEE 802.11b Standard
- Wireless LAN Access Points and Bridge Products
- Spread Spectrum WLAN RF Modems
- TDMA or CSMA Packet Protocol Radios
- PCI Wireless LAN Cards (Using Ext. Bridge Chip)
- ISA, ISA PNP WLAN Cards

Microsoft® and Windows® are registered trademarks of Microsoft Corporation.
 PRISM® is a registered trademark of Intersil Americas Inc.
 PRISM and design is a trademark of Intersil Americas Inc.

Simplified Block Diagram

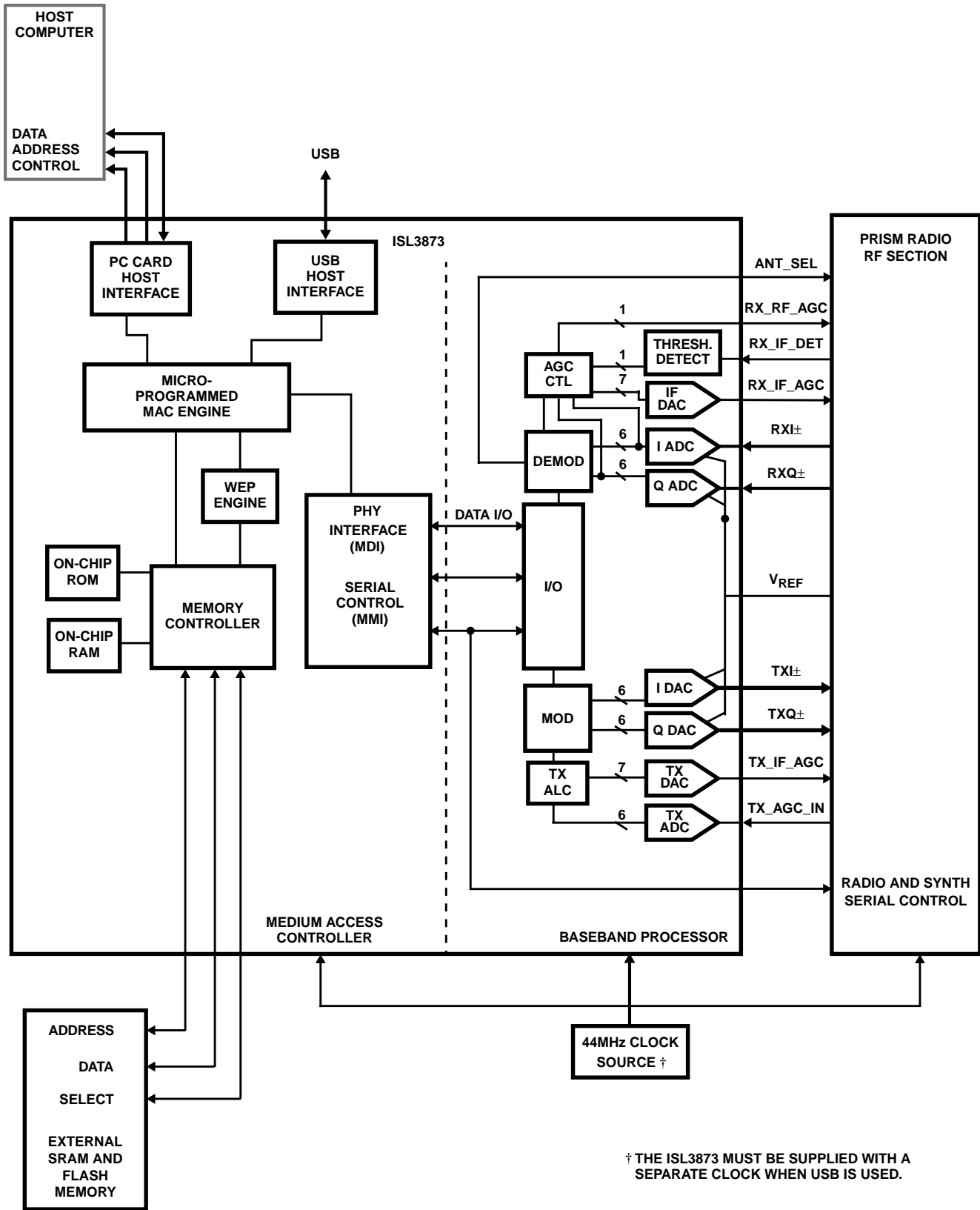

ISL3873 Signal Descriptions**HOST INTERFACE PINS**

PIN NAME	PIN I/O TYPE	DESCRIPTION
HA0-9	5V tol, CMOS, Input, 50K Pull Down	Host PC Card Address Input, Bits 0 to 9
HCE1-	5V tol, CMOS, Input, 50K Pull Up	Host PC Card Select, Low Byte
HCE2-	5V tol, CMOS, Input, 50K Pull Up	Host PC Card Select, High Byte
HD0-15	5V tol, BiDir, 2mA, 50K Pull Down	Host PC Card Data Bus, Bit 0 to 15
HINPACK-	CMOS Output, 2mA	Host PC Card I/O Decode Confirmation
HIORD-	5V tol, CMOS, Input, 50K Pull Up	Host PC Card I/O Space Read Strobe
HIOWR-	5V tol, CMOS, Input, 50K Pull Up	Host PC Card I/O Space Write Strobe
HRDY/HIREQ-	CMOS Output, 4mA	Host PC Card interrupt Request (I/O Mode), also used as PC Card Ready (Memory Mode) output which is asserted to indicate card initialization is complete
HOE-	5V tol, CMOS, Input, 50K Pull Up	Host PC Card Memory Attribute Space Output Enable
HREG-	5V tol, CMOS, Input, 50K Pull Up	Host PC Card Attribute Space Select
RESET	5V tol, CMOS, ST Input, 50K Pull Up	Hardware Reset. Self-asserted by internal pull-up at power-on. Clock signal CLKIN or XTALIN must be available before negation of Reset. Value of MD[15..0] copied to MDIR[15..0] and various control register bits on the first MCLK following release of Reset
HSTSCHG-	CMOS Output, 4mA	Host PC Card Status Change
HWAIT-	CMOS Output, 4mA	Host Wait, asserted to indicate data transfer not complete and to force force host bus wait states
HWE-	5V tol, CMOS Input, 50K Pull Up	Host PC Card Memory Attribute Space Write Enable

USB INTERFACE PINS

PIN NAME	PIN I/O TYPE	DESCRIPTION
USB+	CMOS BiDir, 2mA, (Also USB Transceiver)	USB, MBUS Address Bit 20, or I/O as PL5
USB-	CMOS BiDir, 2mA, (Also USB Transceiver)	USB, MBUS Address Bit 21, or I/O as PL6
USB_DETECT	Input, 5V tolerant, pull-down	Sense USB VBUS to indicate cable attachment

MEMORY INTERFACE PINS

PIN NAME	PIN I/O TYPE	DESCRIPTION
MUBE- / MA0 / MWEH-	CMOS TS Output, 2mA	MBUS Upper Byte Enable for x16 Memory; MBUS Address Bit 0 (byte) for x8 Memory; High Byte Write Enable for 2 x8 Memories
MA1-18	CMOS TS Output, 2mA	MBUS Address Bits 1 to 18
PL4-MA19	CMOS BiDir, 2mA	MBUS Address Bit 19
MLBE-	CMOS TS Output, 2mA, 50K Pull Up	MBUS Lower Byte Enable, or I/O as PM2
MOE-	CMOS TS Output, 2mA	Memory Output Enable
MWE- / MWEL-	CMOS TS Output, 2mA	Low (or only) Byte Memory Write Enable
RAMCS-	CMOS TS Output, 2mA	RAM Select
NVCS-	CMOS TS Output, 2mA	NV Memory Select
MD0-7	5V tol, CMOS, BiDir, 2mA, 100K Pull Up	MBUS Low Data Byte, Bits 0 to 7
MD8-15	5V tol, CMOS, BiDir, 2mA 50K Pull-Downs on MD15, MD14, MD13, MD11, MD10, MD09 50K Pull-Ups MD12, MD08	MBUS High Data Byte, Bits 8 to 15 Default power up states are defined by pull-up and pull-down internal resistors as shown. Device defaults to external EEPROM for boot up mode. Using external 10K resistors, configure these pins according to Table 4 to change power-up configuration

MAC RADIO INTERFACE AND GENERAL PURPOSE PORT PINS

PIN NAME	PIN I/O TYPE	DESCRIPTION OF FUNCTION (IF OTHER THAN I/O PORT)
PJ4	CMOS BiDir, 2mA	PE1
PJ5	CMOS BiDir, 2mA, 50K Pull Up	LE_IF
PJ6	CMOS BiDir, 2mA	LED1
PJ7	CMOS BiDir, 2mA, 50K Pull Up	RADIO_PE
PK0	CMOS BiDir, 2mA, ST, 50K Pull Down	LE_RF
PK1	CMOS BiDir, 2mA, 50K Pull Down	SYNTHCLK
PK2	CMOS BiDir, 2mA, 50K Pull Down	SYNTHDATA
PK3	CMOS BiDir, 2mA	PA_PE
PK4	CMOS BiDir, 2mA	PE2
PK7	CMOS BiDir, 2mA	CAL_EN
PL3	CMOS BiDir, 2mA	TR_SW_BAR
PL7	CMOS BiDir, 2mA, Pull Down	TR_SW

SERIAL EEPROM PORT PINS

PIN NAME	PIN I/O TYPE	DESCRIPTION
PJ0	CMOS BiDir	SCLK, Serial Clock
PJ1	CMOS BiDir, 50K Pull Down	SD, Serial Data Out
PJ2	CMOS BiDir, 50K Pull Down	MISO, Serial Data IN
TCLKIN (CS_)	CMOS BiDir	CS_, Chip Select

CLOCKS PORT PINS

PIN NAME	PIN I/O TYPE	DESCRIPTION
CLKIN	CMOS Input, 50K Pull Down	External Clock Input to MCLK prescaler (at >= 2X Desired MCLK Frequency, Typically 44-48MHz)
XTALIN	Analog Input	32.768kHz Crystal Input
XTALOUT	CMOS Output, 2mA	32.768kHz Crystal Output
CLKOUT	CMOS, TS Output, 2mA	Internal Clock Output (Selectable as MCLK, TCLK, or TOUT0)
BBP_CLK	Input	Baseband Processor Clock. The nominal frequency for this clock is 44MHz. This is used internally to generate divide by 2 and 4 for the transceiver clock

BASEBAND PROCESSOR RECEIVER PORT PINS

PIN NAME	PIN I/O TYPE	DESCRIPTION
RX_IF_AGC	O	Analog drive to the IF AGC control
RX_RF_AGC	O	Drive to the RF AGC stage attenuator. CMOS digital
RX_IF_DET	I	Analog input to the receive power A/D converter for AGC control
RXI, ±	I	Analog input to the internal 6-bit A/D of the In-phase received data. Balanced differential 10+/11-
RXQ, ±	I	Analog input to the internal 6-bit A/D of the Quadrature received data. Balanced differential 13+/14-

BASEBAND PROCESSOR TRANSMITTER PORT PINS

PIN NAME	PIN I/O TYPE	DESCRIPTION
TX_AGC_IN	I	Input to the transmit power A/D converter for transmit AGC control
TX_IF_AGC	O	Analog drive to the transmit IF power control
TXI ±	O	TX Spread baseband I digital output data. Data is output at the chip rate. Balanced differential 23+/24-
TXQ ±	O	TX Spread baseband Q digital output data. Data is output at the chip rate. Balanced differential 29+/30-

ISL3873

MISC CONTROL PORT PINS

PIN NAME	PIN I/O TYPE	DESCRIPTION
ANTSEL	O	The antenna select signal changes state as the receiver switches from antenna to antenna during the acquisition process in the antenna diversity mode. This is a complement for ANTSEL (pin 40) for differential drive of antenna switches
ANTSEL	O	The antenna select signal changes state as the receiver switches from antenna to antenna during the acquisition process in the antenna diversity mode. This is a complement for ANTSEL (pin 39) for differential drive of antenna switches
TestMode	I/O	Factory level test pin. This pin must be pulled low with a 10K resistor.
CompCap1	I	Compensation Capacitor
CompCap2	I	Compensation Capacitor
CompRes1	I	Compensation Resistor
CompRes2	I	Compensation Resistor
DBG(0-4)	I/O	Debug factory test signals. Do not connect

POWER PORT PINS

PIN NAME	PIN I/O TYPE	DESCRIPTION
V _{DDA}	Power	DC Power Supply 2.7 - 3.6V (Not Hardwired Together on Chip)
V _{DD}	Power	DC Power Supply 2.7 - 3.6V
SUPPLY5V	Power	5V Tolerant DC Power Supply
V _{SSA}	Ground	Analog Ground
V _{sub}	Ground	Analog Ground
GND	Ground	Digital Ground
VREF	Input	Voltage Reference for A/D's and D/A's
IREF	Input	Current Reference for internal ADC and DAC devices. Requires 12K resistor to ground.

ST = Schmitt Trigger (Hysteresis), TS = Three-State. Signals ending with "-" are active low.

ISL3873 PIN NUMBER ASSIGNMENTS

PIN NUMBER	SIGNAL NAME	PIN NUMBER	SIGNAL NAME	PIN NUMBER	SIGNAL NAME	PIN NUMBER	SIGNAL NAME
A1	NC	C7	HD4	F4	MA5	K16	V _{DD}
A2	MA10	C8	HD6	F13	HD9		
A3	MA13	C9	HD14	F14	HD10	L1	MD8
A4	MA16	C10	HD11	F15	HA2	L2	MD7
A5	GND	C11	HD7	F16	HA1	L3	MD10
A6	PL4_MA19	C12	HA7			L4	MD9
A7	DBG2	C13	GND	G1	MD12	L13	GND
A8	V _{DD}	C14	DBG3	G2	MD14	L14	RX_RF_AGC
A9	HD3	C15	NC	G3	V _{DD}	L15	ANT_SEL
A10	HCE2	C16	RESET	G4	MA2	L16	ANT_SEL
A11	GND			G13	GND		
A12	HD15	D1	MA3	G14	HSTSCHG	M1	MD5
A13	HA9	D2	MA8	G15	HD0	M2	V _{DD}
A14	V _{DD}	D3	MA7	G16	BBP_CLK	M3	GND
A15	HA6	D4	MA14			M4	MD6
A16	NC	D5	MA17	H1	V _{DD}	M13	V _{DDA}
		D6	DBG0	H2	MLBE	M14	COMP_CAP1
B1	V _{DD}	D7	GND	H3	MD11	M15	GND

ISL3873

ISL3873 PIN NUMBER ASSIGNMENTS (CONTINUED)

PIN NUMBER	SIGNAL NAME	PIN NUMBER	SIGNAL NAME	PIN NUMBER	SIGNAL NAME	PIN NUMBER	SIGNAL NAME
B2	NC	D8	HD5	H4	MD13	M16	V _{DD}
B3	MA9	D9	HIREQ	H13	HD2		
B4	MA12	D10	HIOWR	H14	HD1	N1	MD4
B5	V _{DD}	D11	HOE	H15	HA0	N2	MD0
B6	MA18	D12	NC	H16	HD8	N3	MD3
B7	DBG1	D13	HA5			N4	MD2
B8	HD12	D14	HWAIT	J1	XTALIN	N5	NC
B9	HCE1	D15	SUPPLY5V	J2	XTALOUT	N6	PJ7 (RADIO_PE)
B10	V _{DD}	D16	HREG	J3	RAMCS	N7	PK2 (SYNTHDATA)
B11	HIORD			J4	NVCS	N8	V _{DDA}
B12	HA8	E1	GND	J13	USB_DET	N9	V _{SSA}
B13	HWE	E2	MA4	J14	V _{DD}	N10	V _{SUB}
B14	HA4	E3	GND	J15	USB-	N11	V _{DD}
B15	NC	E4	NC	J16	USB+	N12	IREF
B16	DBG4	E13	HA3			N13	V _{SSA}
		E14	V _{DD}	K1	CLKIN	N14	NC
C1	MA6	E15	HINPACK	K2	MOE	N15	RX_IF_AGC
C2	NC	E16	GND	K3	MWEL	N16	TX_IF_AGC
C3	MA11			K4	GND		
C4	MA15	F1	MD15	K13	TESTMODE		
C5	CLKOUT	F2	MA1	K14	GND		
C6	HD13	F3	MWEH_MA0	K15	GND		
P1	MD1	R1	PJ1 (SDATA)	T1	PJ0 (SCLK)		
P2	PJ2 (MISO)	R2	NC	T2	V _{DD}		
P3	TCLKIN	R3	NC	T3	PJ6 (LED1)		
P4	PJ5 (LE_IF)	R4	PJ4 (PE1)	T4	PK1 (SYNTHCLK)		
P5	GND	R5	PK0 (LE_RF)	T5	PK4 (PE2)		
P6	PL7 (TR_SW)	R6	PK3 (PA_PE)	T6	PL3 (TR_SW_BAR)		
P7	PK7 (CAL_EN)	R7	RXI+	T7	RXI-		
P8	V _{DDA}	R8	V _{DDA}	T8	V _{DDA}		
P9	GND	R9	RXQ+	T9	RXQ-		
P10	V _{SUB}	R10	RX_IF_DET	T10	TX_AGC_IN		
P11	VREF	R11	V _{DDA}	T11	V _{SSA}		
P12	V _{DDA}	R12	TXI+	T12	TXI-		
P13	COMPRES2	R13	COMCAP2	T13	V _{SSA}		
P14	NC	R14	TXQ+	T14	TXQ-		
P15	NC	R15	NC	T15	COMPRES1		
P16	NC	R16	NC	T16	NC		

Absolute Maximum Ratings

Supply Voltage, V_{CC} 3.6V
 Input, Output or I/O Voltage GND -0.5V to V_{CC} +0.5V
 ESD Classification Class 2

Operating Conditions

Voltage +3.3V
 Ambient Temperature Range -40°C to 85°C

Thermal Information

Thermal Resistance (Typical, Note 1) θ_{JA} (°C/W)
 BGA Package 55
 Maximum Storage Temperature Range -65°C to 150°C
 Maximum Junction Temperature 100°C
 Maximum Lead Temperature (Soldering 10s) 300°C
 (Lead Tips Only)

CAUTION: Stresses above those listed in "Absolute Maximum Ratings" may cause permanent damage to the device. This is a stress only rating and operation of the device at these or any other conditions above those indicated in the operational sections of this specification is not implied.

NOTE:

1. θ_{JA} is measured with the component mounted on an evaluation PC board in free air.

DC Electrical Specifications

PARAMETER	SYMBOL	TEST CONDITIONS	MIN	TYP	MAX	UNITS
Power Supply Current	I_{CCOP}	$V_{CC} = 3.6V$, CLK Frequency 44MHz	-	-	175	mA
Input Leakage Current	I_I	$V_{CC} = \text{Max}$, Input = 0V or V_{CC}	-10	1	10	mA
Output Leakage Current	I_O	$V_{CC} = \text{Max}$, Input = 0V or V_{CC}	-10	1	10	mA
Logical One Input Voltage	V_{IH}	$V_{CC} = \text{Max}$, Min	$0.7V_{CC}$	-	-	V
Logical Zero Input Voltage	V_{IL}	$V_{CC} = \text{Min}$, Max	-	-	$0.3V$	V
Logical One Output Voltage	V_{OH}	$I_{OH} = -1mA$, $V_{CC} = \text{Min}$	$0.9V_{CC}$	-	-	V
Logical Zero Output Voltage	V_{OL}	$I_{OL} = 2mA$, $V_{CC} = \text{Min}$	-	0.1	$0.1V_{CC}$	V
Input Capacitance	C_{IN}	CLK Frequency 1MHz. All measurements referenced to GND. $T_A = 25^\circ C$	-	5	10	pF
Output Capacitance	C_{OUT}	CLK Frequency 1MHz. All measurements referenced to GND. $T_A = 25^\circ C$	-	5	10	pF

NOTE: All values in this table have not been measured and are only estimates of the performance at this time.

AC Electrical Specifications

PARAMETER	SYMBOL	MIN	TYP	MAX	UNITS
CLOCK SIGNAL TIMING					
OSC Clock Period (Typ. 44MHz)	t_{CYC}	20	20.8	200	ns
High Period	t_{H1}	10	10.4	-	-
Low Period	t_{L1}	10	10.4	-	-
EXTERNAL MEMORY READ INTERFACE					
MOE-Setup Time from RAMCS_	t_{S1}	0	-	-	ns
MOE_Setup Time from MA (17..0)	t_{S2}	0	-	-	ns
MA (17..1) Hold Time from MOE_ Rising Edge	t_{H1}	20	-	-	ns
RAMCS_ Hold from MOE_ Rising Edge	t_{H2}	20	-	-	ns
MD (15..0) Enable from MOE_ Falling	t_{E1}	5	-	-	ns
MO (15..0) Disable from MOE_ Rising Edge	t_{D1}	-	-	100	ns
EXTERNAL MEMORY WRITE INTERFACE					
MA (17..0) Setup to MWE_ Falling Edge	t_{S3}	0	0	0	ns
RAMCS_ Setup to MWE	t_{S4}	0	-	-	ns
MA (17..0) Hold from MWE_ Rising Edge	t_{H3}	15	-	-	ns
RAMCS_ Hold from MWE_ Rising Edge	t_{H4}	15	-	-	ns
MD (15..0) Setup to MWE_ Rising Edge	t_{S5}	40	-	-	ns
MD (15..0) Hold from MWE_ Rising Edge	t_{H5}	15	-	-	ns
SYNTHESIZER					
SYNTHCLK(PK1) Period	t_{CYC}	83	-	4,000	ns

AC Electrical Specifications (Continued)

PARAMETER	SYMBOL	MIN	TYP	MAX	UNITS
SYNTHCLK(PK1) Width Hi	t _{H1}	t _{CYC} /2 - 10	-	t _{CYC} /2 + 10	ns
SYNTHCLK(PK1) Width Lo	t _{L1}	t _{CYC} /2 - 10	-	t _{CYC} /2 + 10	ns
SERIAL PORT					
SYNTHCLK(PK1) Clock Period	t _{CYC}	83ns	-	4000	ns
Low Width	t _{H1} , t _{L1}	t _{CYC} /2 - 10	-	t _{CYC} /2 + 10	ns
Delay from Clock Falling Edge to SPCSx, SPAS, SPREAD, SYNTHDATA(PK2) Outputs	t _{CD}	-	10	-	ns
Setup Time of SYTHNDATA(PK2) Read to SYTHNCLK(PK1) Falling Edge	t _{DRS}	15	-	-	ns
Hold Time of SYTHNDATA(PK2) Read from SYTHNCLK(PK1) Falling Edge	t _{DRH}	0	-	-	
Hold Time of SYTHNDATA(PK2) Write from SYTHNCLK(PK1) Falling Edge	t _{DWH}	0	-	-	
SYSTEM INTERFACE - PC CARD IO READ 16					
Data Delay After HIORD-	t _{DIORD}	-	-	100	ns
Data Hold Following HIORD-	t _{HIORD}	0	-	-	ns
HIORD- Width Time	t _{WIORD}	165	-	-	ns
Address Setup Before HIORD-	t _{SUA}	70	-	-	ns
Address Hold Following HIORD-	t _{HA}	20	-	-	ns
HCE(1,2)- Setup Before HIORD-	t _{SUCE}	5	-	-	ns
HCE(1,2)- Hold After HIORD-	t _{HCE}	20	-	-	ns
HREG- Setup Before HIORD-	t _{SUREG}	5	-	-	ns
HREG- Hold Following HIORD-	t _{HREG}	0	-	-	ns
HINPACK- Delay Falling from HIORD-	t _{DFINPACK}	0	-	45	ns
HINPACK- Delay Rising from HIORDN	t _{DRINPACK}	30	-	45	ns
HWAIT-	t _{DFWT}	-	-	35	ns
Data Delay from HWAIT- Rising	t _{DRWT}	-	-	0	ns
HWAIT- Width Time	t _{WWT}	-	-	12,000	ns
SYSTEM INTERFACE - PC CARD IO WRITE 16					
Data Setup Before HIOWR-	t _{SUIOWR}	30	-	92	ns
Data Hold Following HIOWR-	t _{HIOWR}	20	-	-	ns
HIOWRN- Width Time	t _{WIOWR}	165	-	-	ns
Address Setup Before HIOWR-	t _{SUA}	70	-	-	ns
Address Hold Following HIOWR-	t _{HA}	20	-	-	ns
HCE(1,2)- Setup Before HIOWR-	t _{SUCE}	5	-	-	ns
HCE(1,2)- Hold Following HIOWR-	t _{HCE}	20	-	-	ns
HREG- Setup Before HIOWR-	t _{SUREG}	5	-	-	ns
HREG- Hold Following HIOWR-	t _{HREG}	0	-	-	ns
HWAIT- Delay Falling from HIOWR-	t _{DFWT}	-	-	35	ns
HWAIT- Width Time	t _{WWT}	-	-	12,000	ns
HIOWRN High from HWAIT- High	t _{DRIOWR}	0	-	-	ns
BASEBAND SIGNALS					
Full Scale Input Voltage (V _{p-p})		0.25	0.50	1.0	V
Input Bandwidth (-0.5dB)		-	20	-	MHz
Input Capacitance		-	5	-	pF
Input Impedance (DC)		5	-	-	kΩ
FS (Sampling Frequency)		-	-	22	MHz

Waveforms

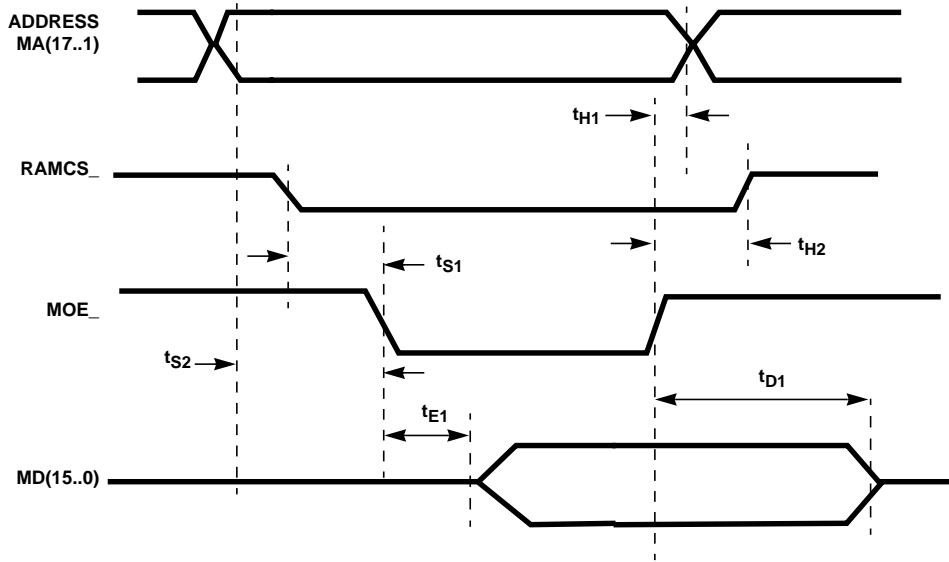

FIGURE 1. EXTERNAL MEMORY READ TIMING

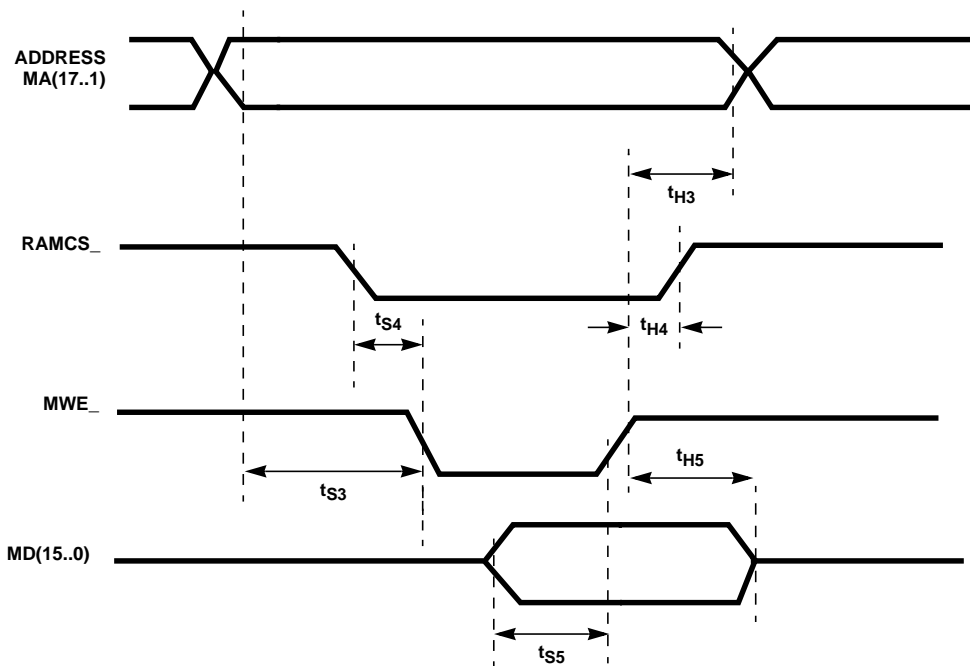

FIGURE 2. EXTERNAL MEMORY WRITE TIMING

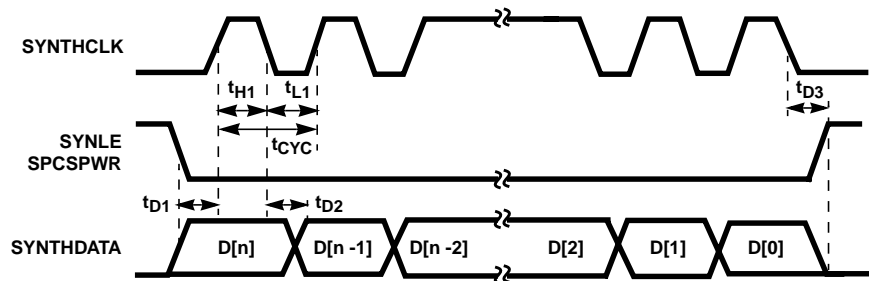

FIGURE 3. SYNTHESIZER

Waveforms (Continued)

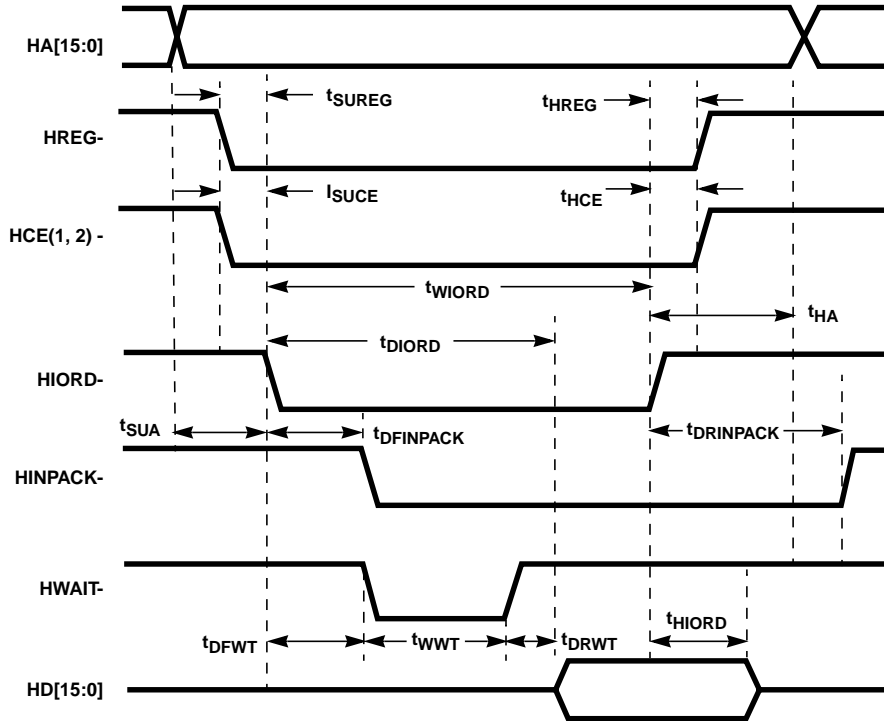

FIGURE 4. PC CARD IO READ 16

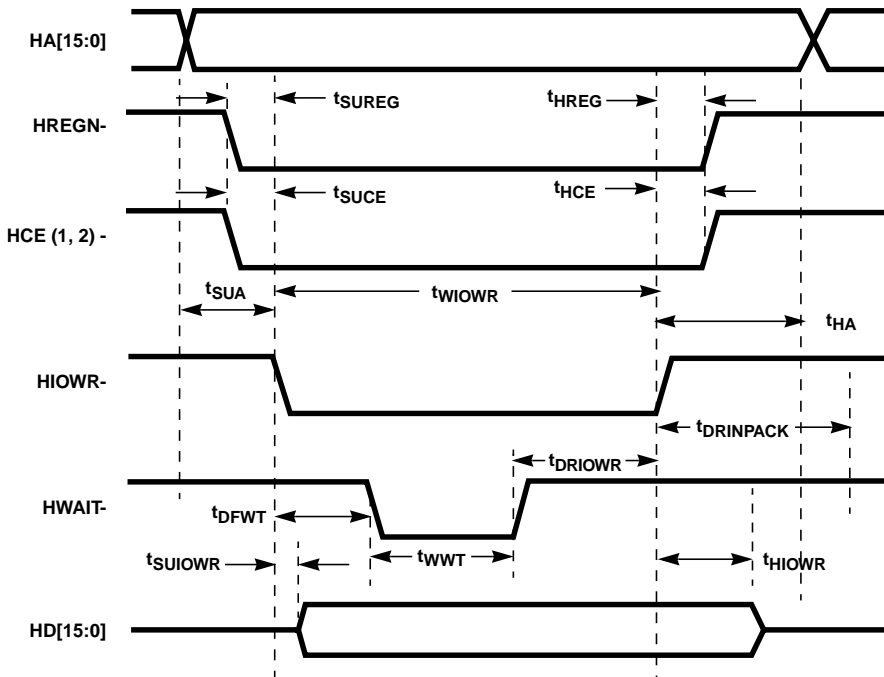

FIGURE 5. PC CARD IO WRITE 16

ISL3873 MAC System Overview

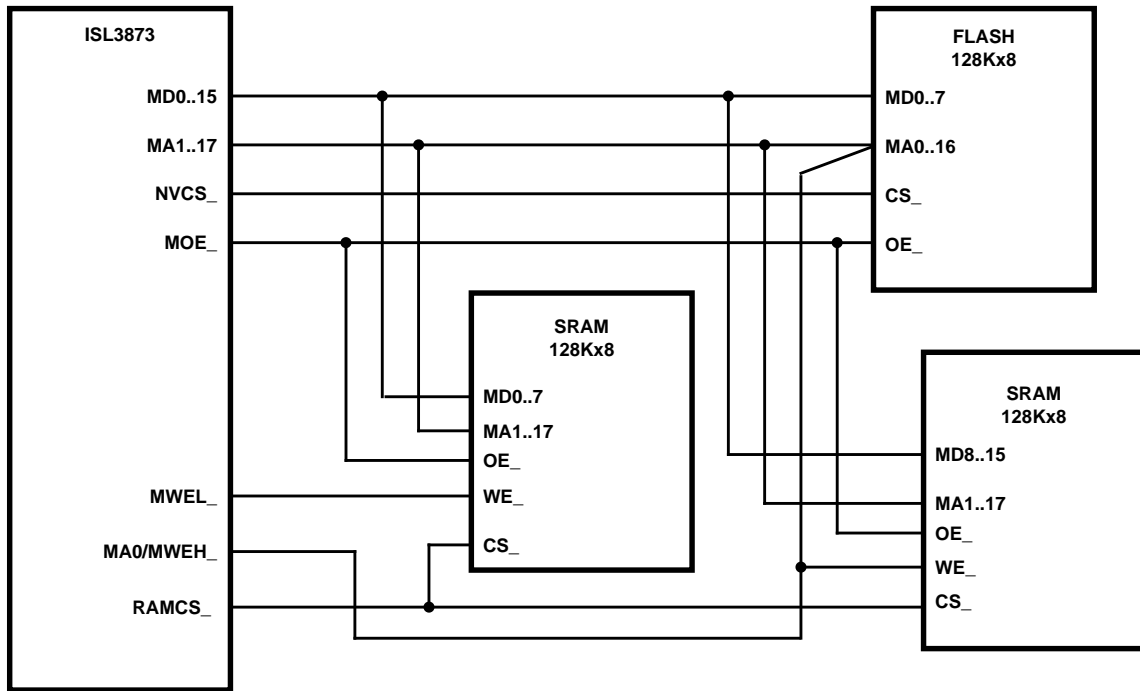

FIGURE 6. 8-BIT MEMORY INTERFACE REQUIREMENTS FOR ISL3873

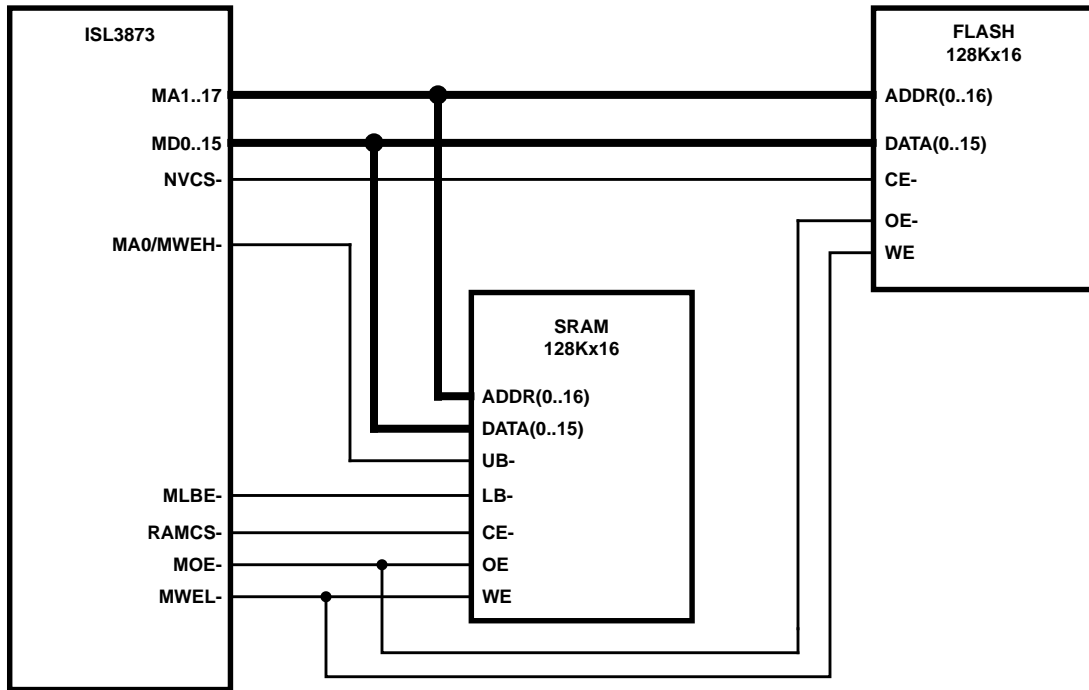

FIGURE 7. 16-BIT MEMORY INTERFACE REQUIREMENTS FOR ISL3873

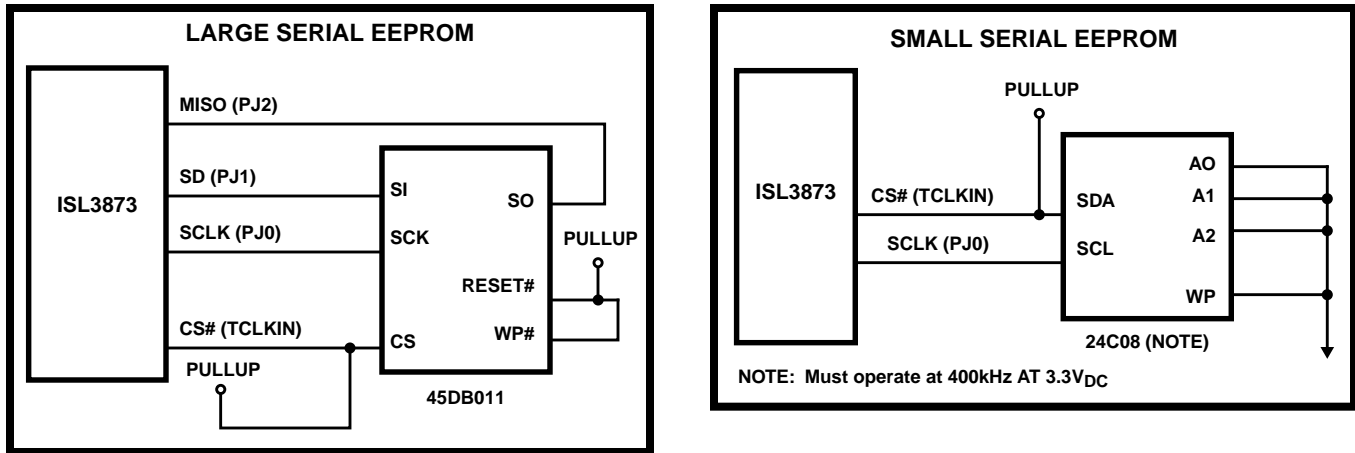

FIGURE 8. SERIAL EEPROM INTERFACE

External Memory Interface

The ISL3873 provides separate external chip selects for code space and data storage space. Code space is accessible as data space through an overlay mechanism, except for an internal ROM. Refer to Figures 6, 7 and 8 for ISL3873 memory configuration detail examples.

The maximum possible memory space size is 4Mbytes. If USB is the host interface, this is reduced to 1Mbyte.

Most of the data store space is reserved for storage of received and transmitted data, with some areas reserved for use by firmware. However, a portion of the data store may be allocated as code store. This permits higher speed instruction execution, by using fast RAMs, than is possible from Flash memories. The maximum size of this overlay is the full code space address range, 128Kbytes, and is allocated in independent sections of 16Kbytes each, on 16Kbyte boundaries, ranging from the highest address of the actual physical memory space and extending down.

Mapping code execution to RAM requires the RAM to have code written into it. Typically, this is done by placing code in a non-volatile memory such as a Flash in the code space. At initialization, the code in the non-volatile memory transfers itself to RAM, maps the appropriate blocks of the code space to the RAM, and then branches to begin execution from RAM. This allows low cost, slow Flash devices to hold an entire code image, which can be executed much faster from RAM. If code is not placed in an external non-volatile memory as described here, it must be transferred to the RAM via the Host Interface.

Slow memories are not dynamically sensed. Following reset, the instruction clock operates with a slower cycle while the Flash is copied to RAM. Once code has been copied from Flash to RAM, execution transfers to RAM and the clock is raised to the normal operating frequency.

As mentioned above, it is feasible to operate without a code image in a non-volatile memory. In such a system, the

firmware must be downloaded to RAM through the host interface before operation can commence.

The external SRAM memory must be organized in a 16-bit width to provide adequate performance to implement the 802.11 protocol at 11Mb/s rates. Systems designed for lower performance applications may be able to use 8-bit wide memory.

The minimum external memory is 128Kbytes of SRAM, organized 8 or 16 bits wide. Typical applications, including 802.11 station designs, use 256Kbytes organized 128K x 16. An access point application could make use of the full address space of the device with 4Mbytes organized a 2M x 16.

The ISL3873 supports 8 or 16-bit code space, and 8 or 16-bit data space. Code space is typically populated with the least expensive Flash memory available, usually an 8-bit device. Data space is usually populated with high-speed RAMs configured as a 16-bit space. This mixing of 8/16 bit spaces is fully supported, and may be done in any combination desired for code and data space.

The ISL3873 supports direct control of single chip 16-bit wide SRAMs with high/low byte enables, as well as direct control of a 16-bit space constructed from 8-bit wide SRAMs. The type of memory configuration is specified via the appropriate MD pin, sensed when the ISL3873 is reset.

ISL3873 pin MUBE-/MA0/MWEH- functions as Address 0 for 8-bit access, (such as Flash) as MWEH (High Byte Write Enable) when two x8 memories are configured as a single x16 space, and as the upper Byte Enable when a single x16 memory is used. No external logic is required to generate the required signals for both types of memory configurations, even when both exist together; all that is required is for the ISL3873 code to configure the ISL3873 memory controller to generate the proper signals for the particular address space being accessed.

For 8-bit spaces, the ISL3873 dynamically configures pin MUBE-/MA0/MWEH- cycle-by-cycle as the address LSB. MWEL-/MWE- is the only write control, and MOE- is the read output enable.

For 16-bit spaces constructed from 8-bit memories, the ISL3873 dynamically configures pin MUBE-/MA0/MWEH- cycle-by-cycle as the high byte write enable, MWEL- as the low write enable signal, and MOE- as the read output enable.

For 16-bit spaces constructed from single-chip x16 memories (such as SRAMs), the ISL3873 dynamically configures pin MUBE-/MA0/MWEH- cycle-by-cycle as the upper byte enable. Pin MLBE- is connected as the low byte enable, MWEL-/MWE- is the write control, and MOE- is the read output enable.

These memory implementations require no external logic. The memory spaces may each be constructed from any type of memory desired. The only restriction is that a single memory space must be constructed from the same type of memory; for example, data space may not use both x8 and x16 memories, it must be all x8, or all x16. This restriction does not apply across memory spaces; e.g., code space may use a x8 memory and data space a single x16 memory, or code space two x8 memories and data space a single x8 memory.

Serial EEPROM Interface

The ISL3873 contains a small on-chip ROM firmware which was added to allow the CIS or CIS plus firmware image to be transferred from an off-chip serial non-volatile memory device to RAM after a system reset. This allows a system configuration without a parallel Flash device. The operating frequency of the serial port is 400kHz with a voltage of 3.3V. Refer to Figure 8 for additional details on configuring the serial memory to the ISL3873. The Power On Reset Configuration section in this document provides additional details on memory selection and control after a Reset condition.

PC Card Interface

PC Card Physical Interface

The Host interface is compatible to the PC Card 95 Standard (PCMCIA v2.1). The ISL3873 Host Interface pins connect directly to the correspondingly named pins on the PC Card connector with no external components (other than resistors) required. The ISL3873 operates as an I/O card using less than 64 octet locations. Reads and writes to internal registers and buffer memory are performed by I/O accesses. Attribute memory (256 octets) is provided for the CIS table which is located in external memory. Common memory is not used.

The following describes specific features of various pins:

HA[9:0]

Decoding of the system address space is performed by the HCEx-. During I/O accesses HA[5:0] decode the register.

HA[9:6] are ignored when the internal HAMASK register is set to the defaults used by the standard firmware. During attribute memory accesses HA[9:1] are used.

HD[15:0]

The host interface is primarily designed for word accesses, although all byte access modes are fully supported. See HCE1-, HCE2- for a further description. Note that attribute memory is specified for and operates with even bytes accesses only.

HCE1-, HCE2-

The PC Card cycle type and width are controlled with the CE signals. Word and Byte wide accesses are supported, using the combinations of HCE1-, HCE2-, and HA0 as specified in the PC Card standard.

HWE-, HOE-

HOE- and HWE- are only used to access attribute memory. Common Memory, as specified in the PC Card standard, is not used in the ISL3873. HOE- is the strobe that enables an attribute memory read cycle. HWE- is the corresponding strobe for the attribute memory write cycle. The attribute space contains the Card Information Structure (CIS) as well as the Function Configuration Registers (FCR).

HIORD-, HIOWR-

HIORD- and HIOWR- are the enabling strobes for register access cycles to the ISL3873. These cycles can only be performed once the initialization procedure is complete and the ISL3873 has been put into IO mode.

HREG-

This signal must be asserted for I/O or attribute cycles. A cycle where HREG- is not asserted will be ignored as the ISL3873 does not support common memory.

HINPACK-

This signal is asserted by the ISL3873 whenever a valid I/O read cycle takes place. A valid cycle is when HCE1-, HCE2-, HREG-, and HIORD- are asserted, once the initialization procedure is complete.

HWAIT-

Wait states are inserted in accesses using HWAIT-. The host interface synchronizes all PC Card cycles to the internal ISL3873 clock. The following wait states should be expected:

Direct Read or Write to Hardware Register

- 1/2 to 1 MCLK assertion of HWAIT- for internal synchronization.

Write to Memory Mapped Register, Buffer Access Path, or Attribute Space (Post-Write)

- The data required for the write cycle will be latched and therefore only the synchronizing wait state will occur.
- Until the queued cycle has actually written to the memory, any subsequent access by the Host will result in a WAIT.

Read to Attribute Space and Memory Mapped Registers

- WAIT will assert until the memory arbitration and access have completed.

Buffer Access Paths, BAP0 and BAP1

- An internal Pre-Read cycle to memory is initiated by a host Buffer Read cycle, after the internal address pointer has auto-incremented. If the next host cycle is a read to the same buffer, the data will be available without a memory arbitration delay.
- A single register holds the pre-read data. Thus, any read access to any other memory-mapped register (or the other buffer access path) will result in the pre-read data becoming invalidated.
- If another read cycle has invalidated the pre-read, then a memory arbitration delay will occur on the next buffer access path read cycle.

HIREQ-

Immediately after reset, the HIREQ- signal serves as the RDY/BSY (per the PC Card standard). Once the ISL3873 firmware initialization procedure is complete, HIREQ- is configured to operate as the interrupt to the PC Card socket controller. Both Level Mode and Pulse Mode interrupts are supported. By default, Level mode interrupts are used, so the interrupt source must be specifically acknowledged or disabled before the interrupt will be removed.

RESET

When reset is de-asserted, the CIS table is initialized and, once complete, HIREQ- is set high (HIREQ- acts as RDY/BSY from reset and is set high to indicate the card is ready for use). The CIS table resides in Flash memory and is copied to RAM during firmware initialization. The host system can then initialize the card by reading the CIS information and writing to the configuration register.

ISA PNP

The ISL3873 can be connected to the ISA bus and operate in a Plug and Play environment with an additional chip such as the Fujitsu MB86703, Texas Instruments TL16PNP200A, or Fairchild Semiconductor NM95MS15. See the Application Note AN9874, "ISA Plug and Play with the HFA3841" for more details.

Register Interface

The logical view of the ISL3873 from the host is a block of 32 word wide registers. These appear in IO space starting at the base address determined by the socket controller. There are three types of registers.

Hardware Registers (HW)

- 1 to 1 correspondence between addresses and registers.
- No memory arbitration delay, data transfer directly to/from registers.
- AUX base and offset are write-only, to set up access through AUX data port.

Note: All register cycles, including hardware registers, incur a short wait state on the PC Card bus to insure the host cycle is synchronized with the ISL3873's internal MCLK.

Memory Mapped Registers in Data RAM (MM)

- 1 to 1 correspondence.
- Requires memory arbitration, since registers are actually locations in ISL3873 memory.
- Attribute memory access is mapped into RAM as Base-address + 0x400.
- AUX port provides host access to any location in ISL3873 RAM (reserved).

Buffer Access Path (BAP)

- No 1 to 1 correspondence between register address and memory address (due to indirect access through buffer address pointer registers).
- Auto increment of pointer registers after each access.
- Require memory arbitration since buffers are located in ISL3873 memory.
- Buffer access may incur additional delay for Hardware Buffer Chaining.

Buffer Access Paths

The ISL3873 has two independent buffer access paths, which permits concurrent read and write transfers. The firmware provides dynamic memory allocation between Transmit and Receive, allowing efficient memory utilization. On-the-fly allocation of (128-byte) memory blocks as needed for reception wastes minimal space when receiving fragments. The ISL3873 hides management of free memory from the driver, and allows fast response and minimum data copying for low latency. The firmware provides direct access to TX and RX buffers based on Frame ID (FID). This facilitates Power Management queuing, and allows dynamic fragmentation and de-fragmentation by the controller. Simple Allocate/De-allocate commands ensure low host CPU overhead for memory management.

Hardware buffer chaining provides high performance while reading and writing buffers. Data is transferred between the host driver and the ISL3873 by writing or reading a single register location (the Buffer Access Path, or BAP). Each access increments the address in the buffer memory. Internally, the firmware allocates blocks of memory as needed to provide the requested buffer size. These blocks may not be contiguous, but the firmware builds a linked list of pointers between them. When the host driver is transferring data through a buffer access path and reaches the end of a physical memory block, hardware in the host interface follows the linked list so that the buffer access path points to the beginning of the next memory block. This process is completely transparent to the host driver, which simply writes or reads all buffer data to the same register. If the host driver attempts to access beyond the end of the allocated buffer, subsequent writes are ignored, and reads will be undefined.

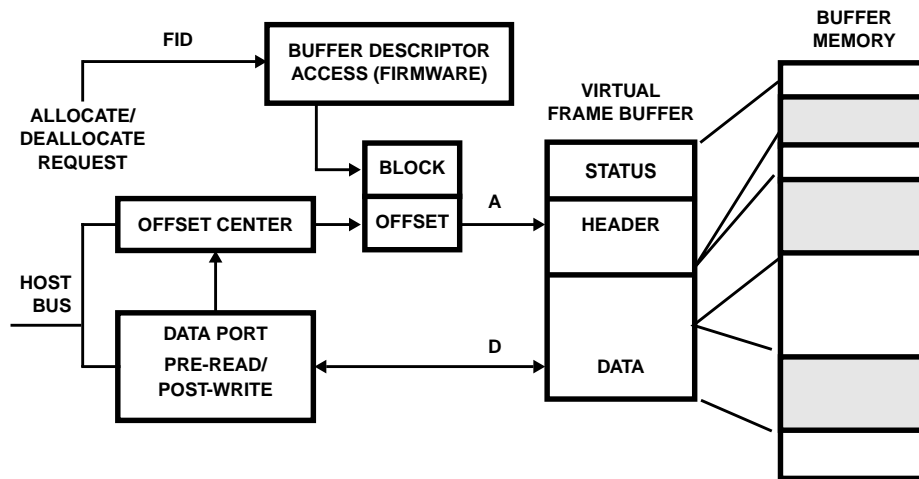

FIGURE 9. BLOCK DIAGRAM OF A BUFFER ACCESS PATH

USB Port

The USB interface implemented in the ISL3873 complies with the Universal Serial Bus Specification Revision 1.1, dated September 23, 1998, which is available from the USB Implementers' Forum at <http://www.usb.org/>.

The USB supports 4 endpoints.

- One Communications Class control endpoint for interface management;
- One Communications Class interrupt endpoint for signalling interrupts to the host; and,
- Two Bulk endpoints for transfer of encapsulated NDIS functions to and from the host.

The USB along with USB support firmware provides an alternate host interface for attaching an 802.11(b) WLAN adapter to a host computer. This interface does not provide "wireless USB" where USB packets are sent on the wireless medium due to timing constraints in the USB protocol.

USB+ and USB- are the differential pair signals provided for the user. These signals are capable of directly driving a USB cable.

USB_DETECT is a 5V tolerant input to the ISL3873 device. It is used to signal the MAC processor that a USB cable is attached to the unit.

Complete details on the USB firmware for controlling this port can be obtained by contacting the factory directly.

Power Sequencing

The ISL3873 provides a number of firmware controlled port pins that are used for controlling the power sequencing and other functions in the front end components of the radio.

Packet transmission requires precise control of the radio. Ideally, energy at the antenna ceases after the last symbol of information has been transmitted. Additionally, the

transmit/receive switch must be controlled properly to protect the receiver. It's also important to apply appropriate modulation to the PA while it's active.

Signaling sequences for the beginning and end of normal transmissions are illustrated in Figure 10. Table 1 lists applicable delays associated with these control signals.

A transmission begins with PE2 as shown in Figure 10. Next, the transmit/receive switch is configured for transmission via the differential pair TR_SW and TR_SW_BAR. This is followed by a transmit enable (TX_ENABLE) to the Baseband processor inside the ISL3873. This enable activates the transmit state machine in the BBP. Lastly, PA_PE activates the PA. Delays for these signals related to the initiation of transmission are referenced to PE2.

Immediately after the final data bit has been clocked out of the MAC the Baseband processor is disabled. The MAC then waits for a control signal (TX_READY) from the Baseband processor to go inactive, signaling that the BBP has modulated the final information-rich symbol. It then immediately de-asserts PA_PE followed by placing the transmit/receive switch in the receive position and ending with PE2 going high. Delays for these signals related to the termination of transmission are referenced to the rising edge of PE2.

TABLE 1. TRANSMIT CONTROL TIMING SPECIFICATIONS

PARAMETER	SYMBOL	DELAY	TOLERANCE	UNITS
PE2 to TR Switch	t_{D1}	2	± 0.1	μs
PE2 to PA_PE	t_{D3}	3	± 0.1	μs
PA_PE to PE2	t_{D4}	3	± 0.1	μs
TR Switch to PE2	t_{D5}	2	± 0.1	μs

PE1 and PE2 encoding details are found in Table 2.

Note that during normal receive and transmit operation that PE1 is static and PE2 toggles for receive and transmit states.

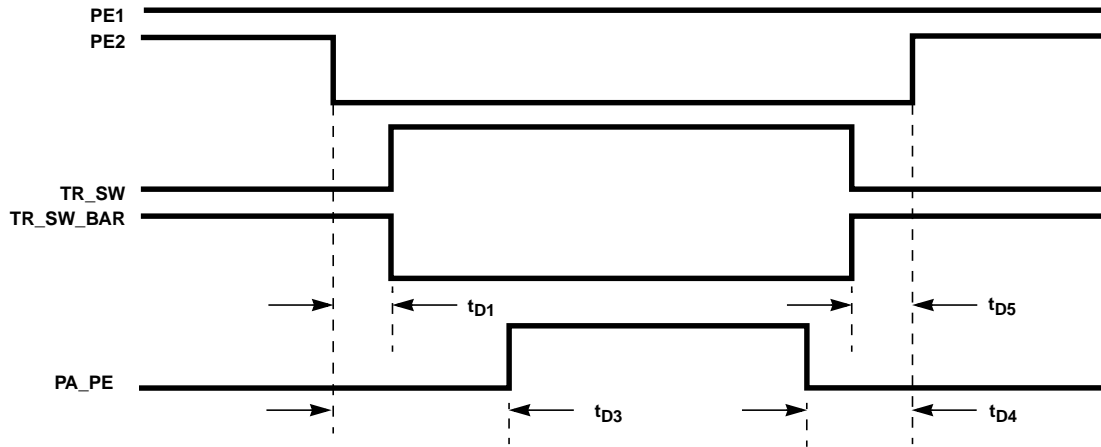

FIGURE 10. TRANSMIT CONTROL SIGNAL SEQUENCING

TABLE 2. POWER ENABLE STATES

	PE1	PE2	PLL_PE
Power Down State	0	0	1
Receive State	1	1	1
Transmit State	1	0	1
PLL Active State	0	1	1
PLL Disable State	X	X	0

PLL_PE is controlled via the serial interface, and can be used to disable the internal synthesizer, the actual synthesizer control is an AND function of PLL_PE, and a result of the OR function of PE1 and PE2. PE1 and PE2 will directly control the power enable functionality of the LO buffer(s)/phase shifter.

Master Clock

Prescaler

The ISL3873 contains a clock prescaler to provide flexibility in the choice of clock input frequencies. For 11Mb/s operation, the internal master clock, MCLK, must be between 11MHz and 16MHz. The clock generator itself requires an input from the prescaler that is twice the desired MCLK frequency. Thus the lowest oscillator frequency that can be used for an 11MHz MCLK is 22MHz. The prescaler can divide by integers and 1/2 steps (IE 1, 1.5, 2, 2.5). Another way to look at it is that the divisor ratio between the external clock source and the internal MCLK may be integers between 2 and 14.

Typically, the 44MHz baseband clock is used as the input, and the prescaler is set to divide by 2. Another useful configuration is to set the prescaler to divide by 1.5 (resulting in 44MHz \pm 3) for an MCLK of 14.67MHz. Contact the factory for further details on setting the clock prescaler register in the ISL3873.

Low-Frequency Crystal

The ISL3873 MAC controller can accept the same clock signal as the PHY baseband processor (typically 44MHz), thereby avoiding the need for a separate, MAC-specific oscillator. The ISL3873 input has a low-frequency oscillator. This low-frequency oscillator is intended for use with a 32.768KHz,

tuning-fork type watch crystal to permit accurate timekeeping with very low power consumption during sleep state.

If a 32.768KHz crystal is connected, the resulting LF clock is supplied to an interval timer to permit measuring sleep intervals as well as providing a programmable wake-up time. In addition, the clock generator can operate either from CLKIN or (very slowly) from the LF clock. Glitch-free switching between these two clock sources, under firmware control, is provided by two, non-architectural Strobe functions ("FAST" and "SLOW"). In addition, during hardware reset, the clock generator source is set to the LF clock if no edges are detected on CLKIN for two cycles of the LF clock (roughly 61 microseconds). This allows proper initialization with omission of either clock source, since without the LF crystal attached there will not be cycles of the LF clock to activate the detection circuit. The ability to initialize the ISL3873 using the LF oscillator to generate MCLK allows the high-frequency (PHY) oscillator to be powered down during sleep state. If this is done, firmware can turn on power to the PHY oscillator upon wake-up, and use the interval timer to measure the start-up and stabilization period before switching to use CLKIN.

Clock Generator

The ISL3873 can operate with MCLK frequencies up to at least 25MHz and CLKIN frequencies of at least 50MHz. The MCLK prescaler generates MCLK (and QCLK) from the external clock provided at the CLKIN input, or from the output of the LF oscillator. The MCLK prescaler divides the selected input clock by any integer value between 2 and 16, inclusive.

- When using a 44MHz CLKIN, as is typical for 802.11 or 802.11b controllers with a PC Card Host Interface, common divisors are 3 (14.67MHz), 4 (11MHz), or 5 (8.8MHz)
- When using a 48MHz CLKIN, as is typical for 802.11 or 802.11b controllers with a USB host interface, common divisors are 3 (16MHz), 4 (12MHz), or 6 (8MHz)

The MCLK prescaler is set to divide by 16 at hardware reset to allow initialization firmware to be executed from slow

memory devices at any CLKIN frequency. The MCLK prescaler generates glitch free output when the divisor is changed. This allows firmware to change the MCLK frequency during operation, which is especially useful to selectively reduce operating speed, thereby conserving power, when full speed processing is not required.

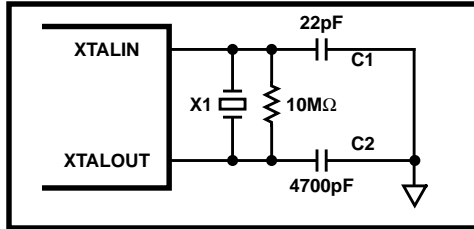

FIGURE 11. 32.768kHz CRYSTAL

Power On Reset Configuration

Power On Reset is issued to the ISL3873 with the RESET pin or via the soft reset bit, SRESET, in the Configuration

Option Register (COR, bit 7). RESET originates from the HOST system which applies RESET for at least 0.01ms after V_{CC} has reached 90% of its end value (see PC-Card standard, Vol. 2, Ch. 4.12.1).

The MD[15:8] pin values are sampled during RESET or Software Reset (SRESET). These pins have internal 50K resistors. External pull-up or pull-down resistors (typically 10kΩ) are used for bits which need to be configured differently than the default.

Table 3 summarizes the effect per pin. Table 4 provides the MD15 and MD14 bit values required to allow the ISL3873 to use Serial EEPROM option.

MD[11], StrIdle, has no equivalent functionality in any control register. When asserted at reset, it will inhibit firmware execution. This is used to allow the initial download of firmware in "Genesis Mode". See the Hardware Reference Manual for more details. The latch is cleared when the Software Reset, SRESET, COR(7) is active.

TABLE 3. INITIALIZATION STRAPPING OPTIONS ON MBUS DATA PINS

BITS	NAME	DEFAULT	FUNCTION
15:14	NVtype[1:0]	30	Indicates type of serial NV memory to be read by initialization firmware in on-chip ROM. Up to 8 NV device types can be encoded with (StrIdle or NVtype). If StrIdle = 0, NV memory holds a firmware image, and NVtype identifies 1 of 4 "large" (= 128Kb) types. If StrIdle = 1, the NV memory just holds the CIS, and NVtype identifies 1 of 4 "small" (<= 8Kb) types.
13	SHIenable	0	Use the Serial Host Interface (USB), and disable all PC Card functions except attribute space, for access to the COR and HCR for firmware debugging support. When = 0, use the Parallel Host Interface (PC Card or ISA).
12	4Wire	1	Use 4-wire interface to SRAM (CS-, OE-, WEH-, WEL-) the ISL3873 x8 SRAMs. When = 0 selects 5-wire interface for use with x16 SRAM (CS-, OE-, WE-, UBE-, LBE-).
11	StrIdle	0	Start idle (wait for download from PC Card host interface).
10	Mem16	0	RAM and NV space at startup is x 16. When = 0 RAM and NV space at startup is x 8. If starting from off-chip NV memory this setting must indicate the width of the startup Flash Memory. During initialization, firmware can set separate widths or RAM and NV space in the Memory Control Register.
9	NVds	0	Disable mapping of off-chip control store to NV space (hence map off-chip control store to RAM space). When = 0 off-chip control store is mapped to NV memory
8	ROMds	1	Disable on-chip control store ROM. When = 0 enable on-chip control store ROM.
7	ISAmode	0	Set host interface control signals and address decoding for PC card. When = 1 set host interface signals and address decoding is for ISA bus, with all registers in I/O space and attribute space disabled. To use ISA mode, PHIenable must be = 1 to enable a parallel host interface.
6	FCRinIO	0	Enable I/O space decoding for the physical FCRs. When = 1, the COR, CSR, and PRR registers are accessible at I/O space offsets 0x40, 0x42, and 0x44 respectively. When = 0 these registers are only accessible in attribute space. This bit is ignored when PHIenable = 0, and is overridden (forced = 1) when ISAmode = 1. FCRinIO = 1 is useful for PC Card operation (PHIenable = 1, ISAmode = 0) to allow non-OS software to access the COR/HCR in OS environments where the system software does not permit application software to access attribute space. ^b
5:0	Spare	0 x 00	Not assigned.

a. FCRinIO = 1 forces HAMASK [0] = 1 to expand I/O space decoding from 0 x 40 to 0 x 80 bytes.

TABLE 4. SERIAL EEPROM SELECTION

MD15	MD14	DEVICE TYPE	FUNCTION
0	0	AT45DB011	Large Serial Device used to transfer firmware to SRAM
0	1	24C08 (Note)	Small Serial Device which contains only CIS. MAC goes idle after loading CIS and waits for host.
1	X	None	Modes not supported in firmware at this time. Consult factory for additional device types added.

NOTE: The operating frequency of the serial port is 400kHz with a voltage of 3.3V.

Baseband Processor

The Baseband Processor operation is controlled by the ISL3873 firmware. Detailed information on programming the Baseband Processor can be obtained by contacting the factory.

BBP Packet Reception

The receive demodulator scrutinizes I and Q for packet activity. When a packet arrives at a valid signal level the demodulator acquires and tracks the incoming signal. It then sifts through the demodulator data for the Start Frame Delimiter (SFD). After SFD is detected, The BBP picks off the needed header fields from the real-time demodulated bitstream.

Assuming all is well with the header, the BBP decodes the signal field in the header and switches to the appropriate data rate. If the signal field is not recognized, or the CRC16 is in error, the demodulator will return to acquisition mode looking for another packet. If all is well with the header, and after the demodulator has switched to the appropriate data rate, then the demodulator will continue to provide data to the MAC in the ISL3873 indefinitely.

RX I/Q A/D Interface

The PRISM baseband processor chip (ISL3873) includes two 6-bit Analog to Digital converters (A/Ds) that sample the balanced differential analog input from the IF down converter device (HFA3783). The I/Q A/D clock, samples at twice the chip rate with a nominal sampling rate of 22MHz.

The interface specifications for the I and Q A/Ds are listed in Table 5. The ISL3873 is designed to be DC coupled to the HFA3783.

TABLE 5. I, Q, A/D SPECIFICATIONS

PARAMETER	MIN	TYP	MAX
Full Scale Input Voltage (V_{P-P})	0.90	1.00	1.10
Input Bandwidth (-0.5dB)	-	11MHz	-
Input Capacitance (pF)	-	2	-
Input Impedance (DC)	5k Ω	-	-
f_S (Sampling Frequency)	-	22MHz	-

The voltages applied to pin 16, V_{REF} and pin 21, I_{REF} set the references for the internal I and Q A/D converters. In addition, For a nominal I/Q input of 400mV_{P-P}, the suggested V_{REF} voltage is 1.2V.

AGC Circuit

The AGC circuit as shown in Figure 12 is designed to adjust for signal level variations and optimize A/D performance for the I and Q inputs by maintaining the proper headroom on the 6-bit converters. There are two gain stages being controlled. At RF, the gain control is a 30dB step change. This RF gain control optimizes the receiver dynamic range when the signal level is high and maintains the noise figure

of the receiver when it is needed most at low signal level. At IF, the gain control is linear and covers the bulk of the gain control range of the receiver.

The AGC loop is partially digital which allows for holding the gain fixed during a packet. The AGC sensing mechanism uses a combination of the I and Q A/D converters and the detected signal level in the IF to determine the gain settings. The A/D outputs are monitored in the ISL3873 for the desired nominal level. When it is reached, by adjusting the receiver gain, the gain control is locked for the remainder of the packet.

RX_AGC_IN Interface

The signal level in the IF stage is monitored to determine when to impose the 30dB gain reduction in the RF stage. This maximizes the dynamic range of the receiver by keeping the RF stages out of saturation at high signal levels. When the IF circuits' sensor output reaches 0.5V_{DD}, the ISL3873 comparator switches in the 30dB pad and also adds 30dB of gain to the IF AGC amplifier. This compensates the IF AGC and RSSI measures.

TX I/Q DAC Interface

The transmit section outputs balanced differential analog signals from the transmit DACs to the HFA3783. These are DC coupled and digitally filtered.

Transmitter Description

The ISL3873 transmitter is designed as a Direct Sequence Spread Spectrum Phase Shift Keying (DSSS PSK) modulator which is capable of handling data rates of up to 11Mbps (refer to AC and DC specifications). The various modes of the modulator are Differential Binary Phase Shift Keying (DBPSK) for 1Mbps, Differential Quaternary Phase Shift Keying (DQPSK) for 2Mbps, and Complementary Code Keying (CCK) for 5.5Mbps and 11Mbps.

CCK is essentially a quadra-phase form of M-ARY Orthogonal Keying. A description of that modulation can be found in Chapter 5 of: "Telecommunications System Engineering", by Lindsey and Simon, Prentiss Hall publishing.

The implemented data rates using a clock rate of 44MHz are shown in Table 6 and the modulation schemes are indicated in Figure 13. The major functional blocks of the transmitter include a Processor Interface, Modulator, Data Scrambler, Preamble/Header Generator, TX Filter, AGC Control, and ADC and DAC circuits. Figure 17 provides a basic block diagram of the DSSS Baseband Processor with an emphasis on the transmitter section. Figure 19 provides a basic block diagram of the DSSS Baseband Processor with an emphasis on the receive section.

The preamble is always transmitted as the DBPSK waveform while the header can be configured to be either DBPSK, or DQPSK, and data packets can be configured for DBPSK, DQPSK, or CCK. The preamble is used by the receiver to

achieve initial Pseudo Noise (PN) synchronization while the header includes the necessary data fields of the communications protocol to establish the physical layer link. The transmitter generates the synchronization preamble and header and knows when to make the DBPSK to DQPSK or CCK switchover, as required.

For the 1 and 2Mbps modes, the transmitter accepts data from the external source, scrambles it, differentially encodes it as either DBPSK or DQPSK, and spreads it with the BPSK PN sequence. The baseband digital signals are then output to the external IF modulator.

For the CCK modes, the transmitter inputs the data and partitions it into nibbles (4 bits) or bytes (8 bits). At 5.5Mbps, it uses two of those bits to select one of 4 complex spread sequences from a table of CCK sequences and then QPSK modulates that symbol with the remaining 2 bits. Thus, there are 4 possible spread sequences to send at four possible carrier phases, but only one is sent. This sequence is then modulated on the I and Q outputs. The initial phase reference for the data portion of the packet is the phase of the last bit of the header. At 11Mbps, one byte is used as above where 6 bits are used to select one of 64 spread sequences for a symbol and the other 2 are used to QPSK modulate that symbol. Thus, the total possible number of combinations of sequence and carrier phases is 256. Of these only one is sent.

Bit rates for the ISL3873 are defined in Table 6. This table provides information on bit rates, data rates and symbol rates for an MCLK of 44MHz clock. Figure 13 shows the modulation schemes for the different bits rates. The modulator is completely independent from the demodulator, allowing the PRISM baseband processor to be used in full duplex operation.

Header/Packet Description

The ISL3873 is designed to handle packetized Direct Sequence Spread Spectrum (DSSS) data transmissions. The ISL3873 generates its own preamble and header information. It uses two packet preamble and header configurations. The first is backwards compatible with the existing IEEE 802.11-1997 1 and 2Mbps modes and the second is the optional shortened mode which maximizes throughput at the expense of compatibility with legacy equipment.

In the long preamble mode, the device uses a synchronization preamble of 128 symbols along with a header that includes four fields. The preamble is all 1's (before entering the scrambler) plus a Start Frame Delimiter (SFD). The actual transmitted pattern of the preamble is randomized by the scrambler. The preamble is always transmitted as a DBPSK waveform (1Mbps). The duration of the long preamble and header is 192µs.

In the short preamble mode, the modem uses a synchronization field of 56 zero symbols along with an SFD transmitted at 1Mbps. The short header is transmitted at 2Mbps. The synchronization preamble is all 0's to distinguish it from the long header mode and the short preamble SFD is the time reverse of the long preamble SFD. The duration of the short preamble and header is 96µs.

Start Frame Delimiter (SFD) Field (16 Bits)

This field is used to establish the link frame timing. The ISL3873 will not declare a valid data packet, even if it PN acquires, unless it detects the SFD. The ISL3873 receiver auto-detects if the packet is long or short preamble and sets SFD time-out. The timer starts counting after initialization of the de-scrambler is complete.

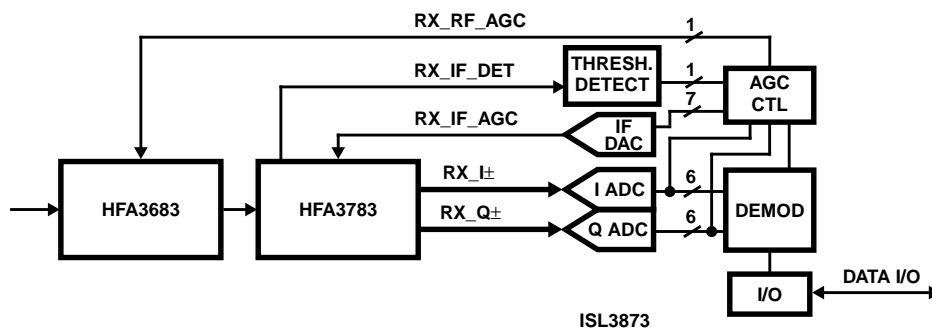

FIGURE 12. AGC CIRCUIT

TABLE 6. BIT RATE TABLE EXAMPLES FOR MCLK = 44MHz

DATA MODULATION	A/D SAMPLE CLOCK (MHz)	TX SETUP CR 5 BITS 1, 0	RX SIGNAL CR 63 BITS 7, 6	DATA RATE (Mbps)	SYMBOL RATE (MSPS)
DBPSK	22	00	00	1	1
DQPSK	22	01	01	2	1
CCK	22	10	10	5.5	1.375
CCK	22	11	11	11	1.375

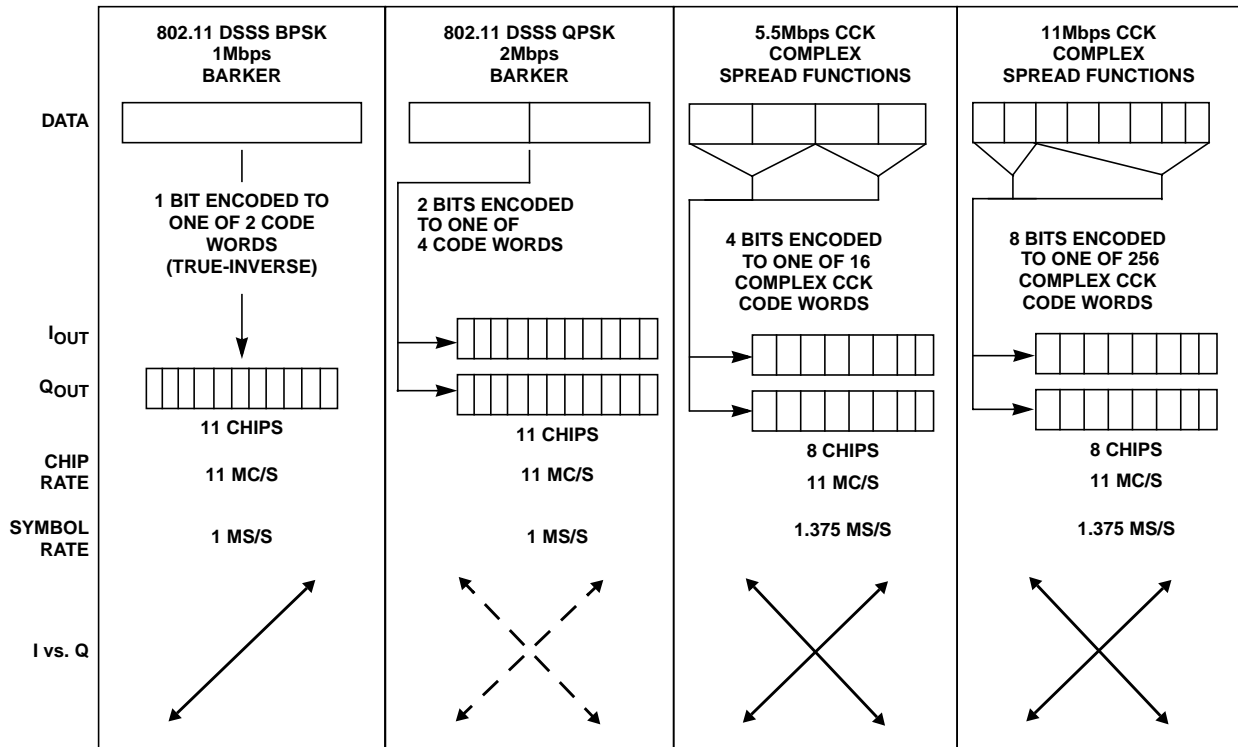

FIGURE 13. MODULATION MODES

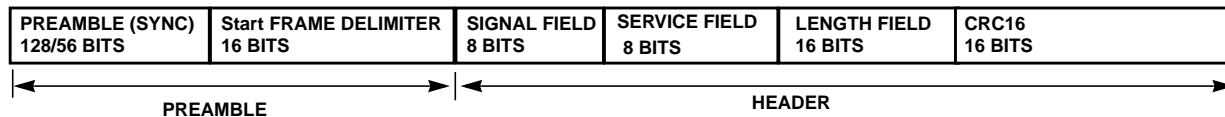

FIGURE 14. 802.11 PREAMBLE/HEADER

Header Field

The header field is defined by four fields which are shown in Figure 14. These fields are Signal Field, Service Field, Length Field and CITT-CRC16 Field. They are further defined by the following:

Signal Field (8 Bits) - This field indicates what data rate the data packet that follows the header will be. The ISL3873 receiver looks at the signal field to determine whether it needs to switch from DBPSK demodulation into DQPSK, or CCK demodulation at the end of the preamble and header fields.

Service Field (8 Bits) - The MSB of this field is used to indicate the correct length when the length field value is ambiguous at 11Mbps. See IEEE STD 802.11 for definition of the other bits. Bit 2 is used by the ISL3873 to indicate that the carrier reference and the bit timing references are derived from the same oscillator (locked oscillators).

Length Field (16 Bits) - This field indicates the number of microseconds it will take to transmit the payload data (PSDU). The external controller (MAC) will check the length field in determining when it needs to de-assert RX_PE.

CCITT - CRC 16 Field (16 Bits) - This field includes the 16-bit CCITT - CRC 16 calculation of the three header fields. This value is compared with the CCITT - CRC 16 code calculated at the receiver. The ISL3873 receiver will indicate a CCITT - CRC 16 error via CR24 bit 2 and will lower MD_RDY and reset the receiver to the acquisition mode if there is an error.

The CRC or cyclic Redundancy Check is a CCITT CRC-16 FCS (Frame Check Sequence). It is the ones complement of the remainder generated by the modulo 2 division of the protected bits by the polynomial:

$$x^{16} + x^{12} + x^5 + 1$$

The protected bits are processed in transmit order. All CRC calculations are made ahead of data scrambling. A shift register with two taps is used for the calculation. It is preset to all ones and then the protected fields are shifted through the register. The output is then complemented and the residual shifted out MSB first.

The following Configuration Registers (CR) are used to program the preamble/header functions, more programming details about these registers can be found in the Control Registers section of this document:

CR 3 - Defines the short preamble length minus the SFD in symbols. The 802.11 protocol requires a setting of 56d = 38h for the optional short preamble.

CR 4 - Defines the long preamble length minus the SFD in symbols. The 802.11 protocol requires a setting of 128d = 80h for the mandatory long preamble.

CR 5 Bits 0, 1 - These bits of the register set the Signal field to indicate what modulation is to be used for the data portion of the packet.

CR 6 - The value to be used in the Service field.

CR 7 and 8 - Defines the value of the transmit data length field. This value includes all symbols following the last header field symbol and is in microseconds required to transmit the data at the chosen data rate.

The packet consists of the preamble, header and MAC Protocol Data Unit (MPDU). The data is transmitted exactly as received from the control processor. Some dummy bits will be appended to the end of the packet to ensure an orderly shutdown of the transmitter. This prevents spectrum splatter. At the end of a packet, the external controller is expected to de-assert the TX_PE line to shut the transmitter down.

Scrambler and Data Encoder Description

The modulator has a data scrambler that implements the scrambling algorithm specified in the IEEE 802.11 standard. This scrambler is used for the preamble, header, and data in all modes. The data scrambler is a self synchronizing circuit. It consists of a 7-bit shift register with feedback from specified taps of the register. Both transmitter and receiver use the same scrambling algorithm. The scrambler can be disabled by setting CR32 bit 2 to 1.

NOTE: Be advised that the IEEE 802.11 compliant scrambler in the ISL3873 has the property that it can lock up (stop scrambling) on random data followed by repetitive bit patterns. The probability of this happening is 1/128. The patterns that have been identified are all zeros, all ones, repeated 10s, repeated 1100s, and repeated 111000s. Any break in the repetitive pattern will restart the scrambler. To ensure that this does not cause any problem, the CCK waveform uses a ping pong differential coding scheme that breaks up repetitive 0's patterns.

Scrambling is done by division with a prescribed polynomial as shown in Figure 15. A shift register holds the last quotient and the output is the exclusive or of the data and the sum of taps in the shift register. The transmit scrambler seed for the long preamble or for the short preamble can be set with CR48 or CR49.

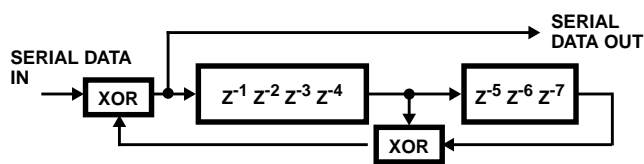

FIGURE 15. SCRAMBLING PROCESS

For the 1Mbps DBPSK data rates and for the header in all rates using the long preamble, the data coder implements the desired DBPSK coding by differential encoding the serial data from the scrambler and driving both the I and Q output channels together. For the 2Mbps DQPSK data rate and for the header in the short preamble mode, the data coder implements the desired coding as shown in the DQPSK Data Encoder Table 7. This coding scheme results from differential coding of dibits (2 bits). Vector rotation is counterclockwise although bits 6 and 7 of configuration register CR 1 can be used to reverse the rotation sense of the TX or RX signal if desired.

Spread Spectrum Modulator Description

The modulator is designed to generate DBPSK, DQPSK, and CCK spread spectrum signals. The modulator is capable of automatically switching its rate where the preamble is DBPSK modulated, and the data and/or header are modulated differently. The modulator can support data rates of 1, 2, 5.5 and 11Mbps. Quadrature (I/Q) modulation is used at the baseband for all modulation modes. Further information on the programming details required to set up the modulator can be obtained by contacting the factory.

TABLE 7. DQPSK DATA ENCODER

PHASE SHIFT	DIBIT PATTERN (d0, d1) d0 IS FIRST IN TIME
0	00
+90	01
+180	11
-90	10

In the 1Mbps DBPSK mode, the I and Q Channels are connected together and driven with the output of the scrambler and differential encoder. The I and Q Channels are then both multiplied with the 11-bit Barker word at the spread rate. The I and Q signals go to the Quadrature upconverter (HFA3724) to be modulated onto a carrier. Thus, the spreading and data modulation are BPSK modulated onto the carrier.

For the 2Mbps DQPSK mode, the serial data is formed into dibits or bit pairs in the differential encoder as detailed above. One of the bits from the differential encoder goes to the I Channel and the other to the Q Channel. The I and Q Channels are then both multiplied with the 11-bit Barker word at the spread rate. This forms QPSK modulation at the symbol rate with BPSK modulation at the spread rate.

CCK Modulation

For the CCK modes, the spreading code length is 8 complex chips and based on complementary codes. The chipping rate is 11Mchip/s. The following formula is used to derive the CCK code words that are used for spreading both 5.5 and 11Mbps:

$$c = \left\{ \begin{array}{l} e^{j(\phi_1 + \phi_2 + \phi_3 + \phi_4)}, e^{j(\phi_1 + \phi_3 + \phi_4)}, e^{j(\phi_1 + \phi_2 + \phi_4)}, \\ -e^{j(\phi_1 + \phi_4)}, e^{j(\phi_1 + \phi_2 + \phi_3)}, e^{j(\phi_1 + \phi_3)}, -e^{j(\phi_1 + \phi_2)}, e^{j\phi_1} \end{array} \right\}$$

(LSB to MSB), where c is the code word.

The terms: φ_1 , φ_2 , φ_3 , and φ_4 are defined below for 5.5Mbps and 11Mbps.

This formula creates 8 complex chips (LSB to MSB) that are transmitted LSB first. The coding is a form of the generalized Hadamard transform encoding where the phase φ_1 is added to all code chips, φ_2 is added to all odd code chips, φ_3 is added to all odd pairs of code chips and φ_4 is added to all odd quads of code chips.

The phase φ_1 modifies the phase of all code chips of the sequence and is DQPSK encoded for 5.5 and 11Mbps. This will take the form of rotating the whole symbol by the appropriate amount relative to the phase of the preceding symbol. Note that the last chip of the symbol defined above is the chip that indicates the symbol's reference phase.

For the 5.5Mbps CCK mode, the output of the scrambler is partitioned into nibbles. The first two bits are encoded as differential symbol phase modulation in accordance with Table 8. All odd numbered symbols of the MPDU are given an extra 180 degree (π) rotation in addition to the standard DQPSK modulation as shown in the table. The symbols of the MPDU shall be numbered starting with "0" for the first symbol for the purposes of determining odd and even symbols. That is, the MPDU starts on an even numbered symbol. The last data dibits d_2 , and d_3 CCK encode the basic symbol as specified in Table 9. This table is derived from the CCK formula above by setting $\varphi_2 = (d_2 \cdot \pi) + \pi/2$, $\varphi_3 = 0$, and $\varphi_4 = d_3 \cdot \pi$. In Table 9 d_2 and d_3 are in the order shown and the complex chips are shown LSB to MSB (left to right) with LSB transmitted first.

TABLE 8. DQPSK ENCODING TABLE

DIBIT PATTERN (d(0), d(1)) d(0) IS FIRST IN TIME	EVEN SYMBOLS PHASE CHANGE (+j ω)	ODD SYMBOLS PHASE CHANGE (+j ω)
00	0	π
01	$\pi/2$	$3\pi/2$ (- $\pi/2$)
11	π	0
10	$3\pi/2$ (- $\pi/2$)	$\pi/2$

TABLE 9. 5.5Mbps CCK ENCODING TABLE

d2, d3	CHIPS							
00	1j	1	1j	-1	1j	1	-1j	1
01	-1j	-1	-1j	1	1j	1	-1j	1
10	-1j	1	-1j	-1	-1j	1	1j	1
11	1j	-1	1j	1	-1j	1	1j	1

At 11Mbps, 8 bits (d_0 to d_7 ; d_0 first in time) are transmitted per symbol.

The first dibit (d_0 , d_1) encodes the phase φ_1 based on DQPSK. The DQPSK encoder is specified in Table 8 above. The phase change for φ_1 is relative to the phase φ_1 of the preceding symbol. In the case of rate change, the phase change for φ_1 is relative to the phase φ_1 of the preceding

CCK symbol. All odd numbered symbols of the MPDU are given an extra 180 degree (π) rotation in accordance with the DQPSK modulation as shown in Table 8. Symbol numbering starts with "0" for the first symbol of the MPDU.

The data dibits: (d_2 , d_3), (d_4 , d_5), (d_6 , d_7) encode φ_2 , φ_3 , and φ_4 respectively based on QPSK as specified in Table 10. Note that this table is binary, not Grey, coded.

Transmit Filter Description

To minimize the requirements on the analog transmit filtering, the transmit section shown in Figure 17 has an output digital filter. This filter is a Finite Impulse Response (FIR) style filter whose passband shape is set by tap coefficients. This filter shapes the spectrum to meet the radio spectral mask requirements while minimizing the peak to average amplitude on the output. To meet the particular spread spectrum processing gain regulatory requirements in Japan on channel 14, an extra FIR filter shape has been included that has a wider main lobe. This increases the 90% power bandwidth from about 11MHz to 14MHz. It has the unavoidable side effect of increasing the amplitude modulation, so the available transmit power is compromised by 2dB when using this filter (CR 11 bit 5).

TABLE 10. QPSK ENCODING TABLE

DIBIT PATTERN (d(i), d(i+1)) d(i) IS FIRST IN TIME	PHASE
00	0
01	$\pi/2$
10	π
11	$3\pi/2$ (- $\pi/2$)

TX Power Control

The transmitter power can be controlled via two registers. The first register, CR58, contains the results of power measurements digitized by the ISL3873. By comparing this measurement to what is needed for transmit power, a determination is made whether to raise or lower the transmit power. It does this by writing the power level desired to register CR31.

Clear Channel Assessment (CCA) and Energy Detect (ED) Description

The Clear Channel Assessment (CCA) circuit implements the carrier sense portion of a Carrier Sense Multiple Access (CSMA) networking scheme. The Clear Channel Assessment (CCA) monitors the environment to determine when it is clear to transmit. The CCA circuit in the ISL3873 can be programmed to be a function of RSSI (energy detected on the channel), CS1, SQ1, or various combinations. The CCA is used by the Media Access Controller (MAC) in the ISL3873. The MAC decides on transmission based on traffic to send and the CCA indication. The CCA indication can be ignored, allowing transmissions independent of any channel conditions. The CCA in combination with the visibility of the

various internal parameters (i.e., Energy Detection measurement results), can assist the MAC in executing algorithms that can adapt to the environment. These algorithms can increase network throughput by minimizing collisions and reducing transmissions liable to errors.

There are three measures that can be used in the CCA assessment. The Receive Signal Strength Indication (RSSI) which indicates the energy at the antenna, CS1 and carrier sense (SQ1). CS1 becomes active anytime the AGC portion of the circuit becomes unlocked, which is likely at the onset of a signal that is strong enough to support 11Mbps, but may not occur with the onset of a signal that is only strong enough to support 1 or 2Mbps. CS1 stays active until the AGC locks and a SQ1 assessment is done, if SQ1 is false, then CS1 is cleared, which deasserts CCA. If SQ1 is true, then tracking is begun, and CCA continues to show the channel busy. CS1 may occur at any time during acquisition as the AGC state machine runs asynchronously with respect to slot times.

SQ1 becomes active only when a spread signal with the proper PN code has been detected, and the peak correlation amplitude to sidelobe ratio exceeds a set threshold, so it may not be adequate in itself.

A SQ1 evaluation occurs whenever the AGC has remained locked for the entire data ingest period. When this happens, SQ1 is updated between 8 and 9 μ s into the 10 μ s dwell. If CS1 is not active, two consecutive SQ1's are required to advance the part to tracking.

The state of CCA is not guaranteed from the time RX_PE goes high until the first CCA assessment is made. At the end of a packet, after RXPE has been deasserted, the state of CCA is also not guaranteed.

The Receive Signal Strength Indication (RSSI) measurement is derived from the state of the AGC circuit. ED is the comparison result of RSSI against a threshold. The threshold may be set to an absolute power value, or it may be set to be N dB above the measured noise floor. See CR 35. The ISL3873 measures and stores the RSSI level when it detects no presence of BPSK or QPSK signals. The average value of a 256 value buffer is taken to be the noise floor. Thus, the value of the noise floor will adapt to the environment. A separate noise floor value is maintained for each antenna. An initial value of the noise floor is established within 50 μ s of the chip being active and is refined as time goes on. Deasserting RX_PE does not corrupt the learned values. If the absolute power metric is chosen, this threshold is normally set to between -70 and -80dBm.

If desired, ED may be used in the acquisition process as well as CCA. ED may be used to mask (squell) weak signals and prevent radio reception of signals too weak to support the high data rates, signals from adjacent cells, networks, or buildings.

The Configuration registers effecting the CCA algorithm operation are summarized below (more programming details

on these registers can be found under the Control Registers section of this document).

The CCA output from pin 60 of the device can be defined as active high or active low through CR 1 (bit 2).

CR9(6:5) allows CCA to be programmed to be a function of ED only, the logical operation of (CS1 OR SQ1), the logical function of (ED AND (CS1 OR SQ1)), or (ED OR (CS1 OR SQ1)).

CR9(7) lets the user select from sampled CCA mode, which means CCA will not glitch, is updated once per symbol and is valid for reading at 15.8 μ s or 18.7 μ s. In non-sampled mode, CCA may change at any time, potentially several times per slot, as ED and CS1 operate asynchronously to slot times.

In a typical system CCA will be monitored to determine when the channel is clear. Once the channel is detected busy, CCA should be checked periodically to determine if the channel becomes clear. Once MD_RDY goes active, CCA should be ignored for the remainder of the message. Failure to monitor CCA until MD_RDY goes active (or use of a time-out circuit) could result in a stalled system as it is possible for the channel to be busy and then become clear without an MD_RDY occurring.

AGC Description

The AGC system consists of the 3 chips handling the receive signal, the RF to IF downconverter HFA3683, the IF to baseband converter HFA3783, and the baseband processor (BBP) section of the ISL3873. The AGC loop (Figure 11) is digitally controlled by the BBP. Basically it operates as follows:

Initially, the receiver is set for high gain. The percent of time that the A/D converters in the baseband processor are saturated is monitored along with signal amplitude and the gain is adjusted down until the amplitude is what will optimize the demodulator's performance. If the amount of saturation is great, the initial gain adjust steps are large. If the signal overload is small, they are less. When the gain is about right and the A/Ds' outputs are within the lock window (CR19), the BBP declares AGC lock and stops adjusting for the duration of the packet. If the signal level then varies more than a preset amount (CR20, CR29), the AGC is declared unlocked and the gain again allowed to readjust.

The BBP looks for the locked state following an unlocked state (CS1) as one indication that a received signal is on the antenna. This starts the receive process of looking for PN correlation (SQ1). Once PN correlation and AGC lock are found, the processor begins acquisition.

For large signals, the power level in the RF stage output is also monitored and if it is large, the LNA stage is shut down. This removes 30dB of gain from the receive chain which is compensated for by replacing 30dB of gain in the IF AGC stage. There is some hysteresis in this operation and once the AGC locks, it is locked as well. This improves the receiver dynamic range.

RX_RF_AGC Pad Operation

30dB Pad Engaging (RF Chip Low Gain):

If the AGC is not locked onto a packet, a '1' on the ifCompDet input will engage in the 30dB attenuation pad. This causes the AGC to go out of lock and also forces the attenuation accumulator to be set to the programmed value of CR27. The AGC then attempts to lock on the signal.

If the AGC is locked on a packet, ifCompDet is ignored.

30DB PAD RELEASING (RF CHIP HIGH GAIN):

If the AGC is not locked onto a packet and the attenuation accumulator sum falls below the programmable threshold (CR27), the pad will release. This is for the case where a noise spike kicked in the 30dB pad and the pad should release when the noise spike ends. Since the noise floor is different for different environments, it is possible that in many cases CR27's programmed value will be below the noise floor and the pad will not be removed except by RXPE going low. There is a recommended value to program CR27 (24dB), but that depends on what environment the radio is in.

During a packet (after AGC lock), the 30dB pad is held constant and the CR27 threshold is ignored.

RXPE low forces the pad to release whether in the middle of a packet or not. At the end of a packet, RXPE always goes low, forcing the pad to release.

Notes: The attenuation accumulator is basically about equal to the current RSSI value.

The accumulator output, after going through the interpolator lookup table, feeds the AGC D/A.

The pad value is programmable (CR17), but is recommended to be set to 30dB.

ifCompDet is a signal from the HFA3783 chip. A '1' indicates its inputs are near saturation and it needs the RF chip to switch from high gain to low gain.

RX_IF_Det is the input to the ISL3873 chip which is connected to **ifCompDet** on the HFA3783.

RX_RF_AGC is the output of the ISL3873 chip and '1' is high gain, '0' is low gain.

Demodulator Description

The receiver portion of the baseband processor, performs A/D conversion and demodulation of the spread spectrum signal. It correlates the PN spread symbols, then demodulates the DBPSK, DQPSK, or CCK symbols. The demodulator includes a frequency tracking loop that tracks and removes the carrier frequency offset. In addition, it tracks the symbol timing, and differentially decodes and descrambles the data. The data is output through the RX Port to the external processor.

The PRISM baseband processor in the ISL3873 uses differentially coherent demodulation. The ISL3873 is designed to achieve rapid settling of the carrier tracking loop during acquisition. Rapid phase fluctuations are handled

with a relatively wide loop bandwidth which is then stepped down as the packet progresses. Coherent processing improves the BER performance margin as opposed to differentially coherent processing for the CCK data rates.

The baseband processor uses time invariant correlation to strip the Barker code spreading and phase processing to demodulate the resulting signals in the header and DBPSK/DQPSK demodulation modes. These operations are illustrated in Figure 18 which is an overall block diagram of the receiver processor.

In processing the DBPSK header, input samples from the I and Q A/D converters are correlated to remove the spreading sequence. The peak position of the correlation pulse is used to determine the symbol timing. The sample stream is decimated to the symbol rate and corrected for frequency offset prior to PSK demodulation. Phase errors from the demodulator are fed to the NCO through a lead/lag filter to maintain phase lock. The carrier is de-rotated by the carrier tracking loop. The demodulated data is differentially decoded and descrambled before being sent to the header detection section.

In the 1Mbps DBPSK mode, data demodulation is performed the same as in header processing. In the 2Mbps DQPSK mode, the demodulator demodulates two bits per symbol and differentially decodes these bit pairs. The bits are then serialized and descrambled prior to being sent to the output.

In the CCK modes, the receiver removes carrier frequency offsets and uses a bank of correlators to detect the modulation. A biggest picker finds the largest correlation in the I and Q Channels and determines the sign of those correlations. For this to happen, the demodulator must know the starting phase which is determined by referencing the data to the last bit of the header. Each symbol demodulated determines 1 or 2 nibbles of data. This is then serialized and descrambled before being passed to the output.

Carrier tracking is via a lead/lag filter using a digital Costas phase detector. Chip tracking in the CCK modes is chip decision directed or slaved to the carrier tracking depending on whether or not the locked oscillator design is utilized in the radio.

Acquisition Description

A projected worst case time line for the acquisition of a signal with a short preamble and header is shown. The synchronization part of the preamble is 56 symbols long followed by a 16-bit SFD. The receiver must monitor the antenna to determine if a signal is present. The timeline is broken into 10µs blocks (dwells) for the scanning process. This length of time is necessary to allow enough integration of the signal to make a good acquisition decision. This worst case time line example assumes that the signal arrives part way into the first dwell such as to just barely catch detection. The signal and the scanning process are asynchronous and the signal could start anywhere. In this timeline, it is assumed that the signal is present in the first 10µs dwell, but was missed due to power amplifier ramp up.

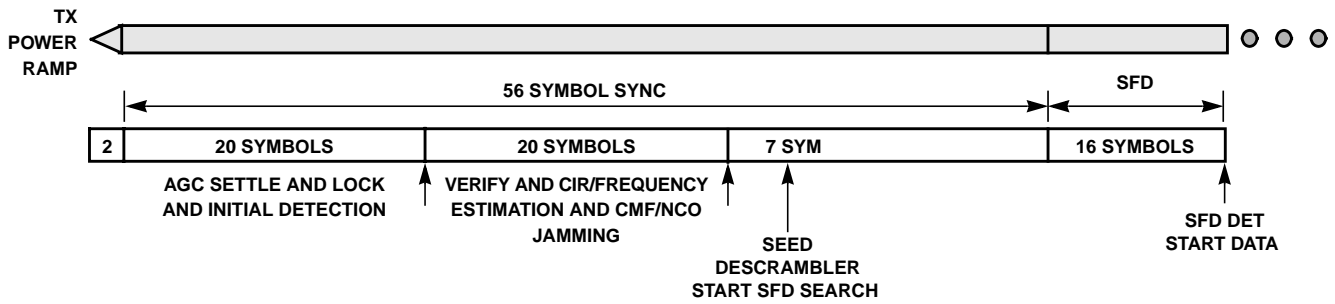

FIGURE 16. ACQUISITION TIMELINE, NON DIVERSITY

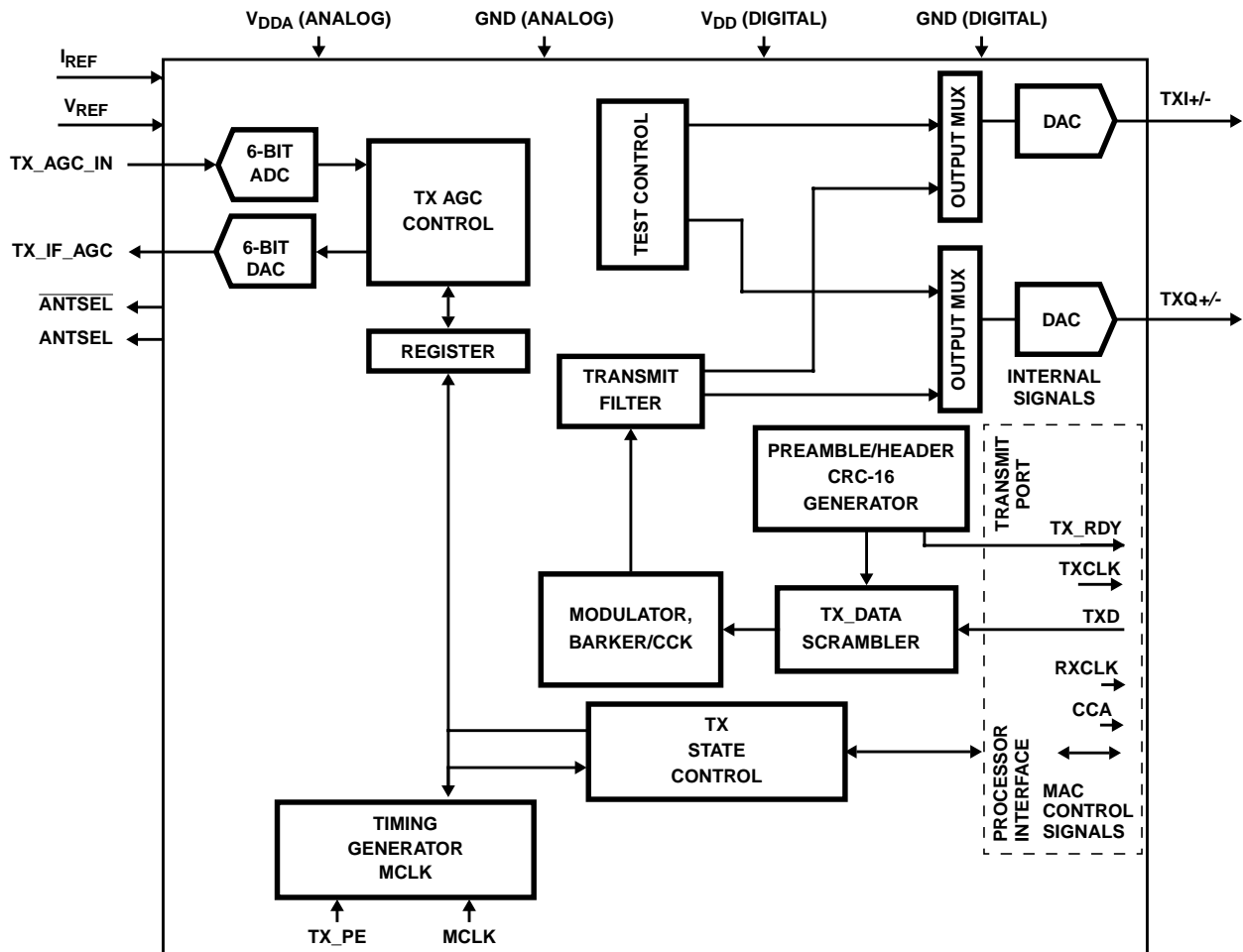

FIGURE 17. DSSS BASEBAND PROCESSOR, TRANSMIT SECTION

Meanwhile signal quality and signal frequency measurements are made simultaneous with symbol timing measurements. A CS1 followed by SQ1 active, or two consecutive SQ1s will cause the part to finish the acquisition phase and enter the tracking phase.

Prior to initial acquisition the NCO is inactive (0Hz) and carrier phase measurement are done on a symbol by symbol basis. After acquisition, coherent DPSK demodulation is in effect. After a brief setup time as illustrated on the timeline, the signal begins to emerge from the demodulator.

It takes 7 more symbols to seed the descrambler before valid data is available. This occurs in time for the SFD to be received. At this time the demodulator is tracking and in the coherent PSK demodulation mode so it will no longer acquire new signals. If a much larger signal overrides the signal being demodulated (a collision), the demodulator will abort the tracking process and attempt to acquire the new signal. Failure to find an SFD within the SFD timeout interval will result in a receiver reset and return to acquisition mode.

Channel Matched Filter (CMF) Description

The receive section shown in Figure 19 operates on the RAKE receiver principle which maximizes the SNR of the signal by combining the energy of multipath signal components. The RAKE receiver is implemented with a Channel Matched Filter (CMF) using a FIR filter structure with 16 taps. The CMF is programmed by calculating the Channel Impulse Response (CIR) of the channel and mathematically manipulating that to form the tap coefficients of the CMF. Thus, the CMF is set to compensate the channel characteristics that distort the signal. Since the calculation of the CIR is inaccurate at low SNR or in the presence of strong CW interference, the chip has thresholds (CR 36 to 39) that are set to substitute a default CMF shape under those conditions. This default CMF shape is designed to compensate only the known transmit and receive non linearity.

PN Correlators Description

There are two types of correlators in the ISL3873 baseband processor. The first is a parallel matched filter correlator that correlates for the Barker sequence used in preamble, header, and PSK data modes. This Barker code correlator is designed to handle BPSK spreading with carrier offsets up to ± 50 ppm and 11 chips per symbol. Since the spreading is BPSK, the correlator is implemented with two real correlators, one for the I and one for the Q Channel. The same Barker sequence is always used for both I and Q correlators.

These correlators are time invariant matched filters otherwise known as parallel correlators. They use one sample per chip for correlation although two samples per chip are processed. The correlator despreads the samples from the chip rate back to the original symbol rate giving 10.4dB processing gain for 11 chips per symbol. While despreads the desired signal, the correlator spreads the energy of any non correlating interfering signal.

The second form of correlator is the parallel correlator bank used for detection of the CCK modulation. For the CCK modes, the 64 wide bank of parallel correlators is implemented with a Fast Walsh Transform to correlate the 4 or 64 code possibilities. This greatly simplifies the circuitry of the correlation function. It is followed by a biggest picker which finds the biggest of 4 or 64 correlator outputs depending on the rate. This is translated into 2 or 6 data bits. The detected output is then processed through the differential phase decoder to demodulate the last two bits of the symbol.

Data Demodulation and Tracking Description (DBPSK and DQPSK Modes)

The signal is demodulated from the correlation peaks tracked by the symbol timing loop (bit sync) as shown in Figure 18. The frequency and phase of the signal is corrected using the NCO that is driven by the phase locked

loop. Averaging the phase errors over 10 symbols gives the necessary frequency information for seeding the NCO operation.

Data Decoder and Descrambler Description

The data decoder that implements the desired DQPSK coding/decoding as shown in Table 11. The data is formed into pairs of bits called dibits. The left bit of the pair is the first in time. This coding scheme results from differential coding of the dibits. Vector rotation is counterclockwise for a positive phase shift, but can be reversed with bit 7 or 6 of CR 1.

For DBPSK, the decoding is simple differential decoding.

TABLE 11. DQPSK DATA DECODER

PHASE SHIFT	DIBIT PATTERN (D0, D1) D0 IS FIRST IN TIME
0	00
+90	01
+180	11
-90	10

The data scrambler and de-scrambler are self synchronizing circuits. They consist of a 7-bit shift register with feedback of some of the taps of the register. The scrambler is designed to ensure smearing of the discrete spectrum lines produced by the PN code.

One thing to keep in mind is that both the differential decoding and the descrambling cause error extension or burst errors. This is due to two properties of the processing. First, the differential decoding process causes errors to occur on pairs of symbols. When a symbol's phase is in error, the next symbol will also be decoded wrong since the data is encoded in the change in phase from one symbol to the next. Thus, two errors are made on two successive symbols. Therefore up to 4 bits may be wrong although on the average only 2 are. In QPSK mode, these may occur next to one another or separated by up to 2 bits. In the CCK mode, when a symbol decision error is made, up to 6 bits may be in error although on average only 3 bits will be in error. Secondly, when the bits are processed by the descrambler, these errors are further extended. The descrambler is a 7-bit shift register with two taps exclusive or'ed with the bit stream. Thus, each error is extended by a factor of three. Multiple errors can be spaced the same as the tap spacing, so they can be canceled in the descrambler. In this case, two wrongs do make a right. Given all that, if a single error is made the whole packet is discarded anyway, so the error extension property has no effect on the packet error rate. It should be taken into account if a forward error correction scheme is contemplated.

Descrambling is self synchronizing and is done by a polynomial division using a prescribed polynomial. A shift register holds the last quotient and the output is the exclusive-or of the data and the sum of taps in the shift register.

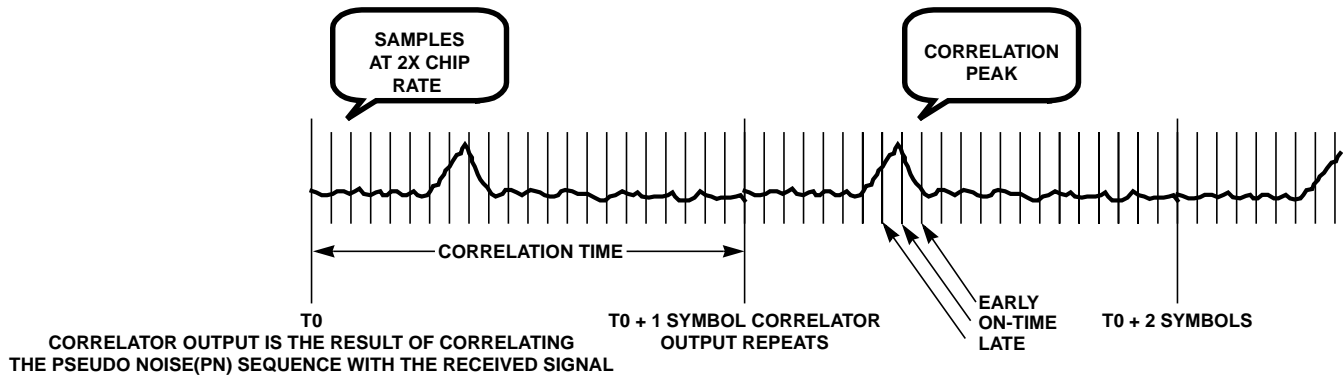

FIGURE 18. CORRELATION PROCESS

Data Demodulation in the CCK Modes

In this mode, the demodulator uses Complementary Code Keying (CCK) modulation for the two highest data rates. It is slaved to the low rate processor which it depends on for acquisition of initial timing and phase tracking information. The low rate section acquires the signal, locks up symbol and carrier tracking loops, and determines the data rate to be used for the MPDU data.

The demodulator for the CCK modes takes over when the preamble and header have been acquired and processed. On the last bit of the header, the phase of the signal is captured and used as a phase reference for the high rate differential demodulator.

The signal from the A/D converters is carrier frequency and phase corrected by a DESPIN stage. This removes the frequency offset and aligns the I and Q Channels properly for the correlators. The sample rate is decimated to 11MSPS for the correlators after the DESPIN since the data is now synchronous in time.

The demodulator knows the symbol timing, so the correlation is batch processed over each symbol. The correlation outputs from the correlator are compared to each other in a biggest picker and the chosen one determines 6 bits of the symbol. The QPSK phase of the chosen one determines two more bits for a total of 8 bits per symbol. Six bits come from which of the 64 correlators had the largest output and the last two are determined from the QPSK differential demod of that output. In the 5.5Mbps mode, only 4 of the correlator outputs are monitored. This demodulates 2 bits for which of 4 correlators had the largest output and 2 more for the QPSK demodulation of that output for a total of 4 bits per symbol.

Equalizer Description

The ISL3873 employs a Decision Feedback Equalizer (DFE) to improve performance in the presence of significant multipath distortion. The DFE combats Inter Chip Interference (ICI) and Inter Symbol Interference (ISI). The equalizer is trained on the sample data collected during the first part of the acquisition after the AGC has settled and the

antenna selected. The same data is used for CMF calculations and equalizer training. Once the equalizer has been set up, it is used to process the incoming symbols in a decision feedback manner. After the Fast Walsh transform is performed, the detected symbols are corrected for ICI before the bigger picker where the symbol decision process is performed. Once a symbol has been demodulated, the calculated residual energy from that symbol is subtracted from the incoming data for the next symbol. That corrects for the ISI component. The DFE is not adapted during the packet as the channel impulse response is not expected to vary significantly during that brief time. Register CR10 bits 4 and 5 can disable these equalizers separately.

Tracking

Carrier tracking is performed on the de-rotated signal samples from the complex multiplier in a four phase Costas loop. This forms the error term that is integrated in the lead/lag filter for the NCO, closing the loop. Tracking is only measured when there is a chip transition. Note that this tracking is dependent on a positive SNR in the chip rate bandwidth.

The symbol clock is tracked by a sample interpolator that can adjust the sample timing forwards and backwards by 72 increments of 1/8th chip. This approach means that the ISL3873 can only track an offset in timing for a finite interval before the limits of the interpolator are reached. Thus, continuous demodulation is not possible.

Locked Oscillator Tracking

Symbol tracking can be slaved to the carrier offset tracking for improved performance as long as at both the transmitting and the receiving radios, the bit clocks and carrier frequency clocks are locked to common crystal oscillators. A bit carried in the SERVICE field (bit 2) indicates whether or not the transmitter has locked clocks. When the same bit is set at the receiver (CR6 bit 2), the receiver knows it can track the bit clock by counting down the carrier tracking offset. This is much more accurate than tracking the bit clock directly. CR33 bit 6 can enable or disable this capability.

Demodulator Performance

This section indicates the typical performance measures for a radio design. The performance data below should be used as a guide. In general, the actual performance depends on the application, interference environment, RF/IF implementation and radio component selection.

Overall E_b/N_0 Versus BER Performance

The PRISM chip set has been designed to be robust and energy efficient in packet mode communications. The demodulator uses coherent processing for data demodulation. The figures below show the performance of the baseband processor when used in conjunction with the HFA3783 IF and the PRISM recommended IF filters. Off the shelf test equipment are used for the RF processing. The curves should be used as a guide to assess performance in a complete implementation.

Factors for carrier phase noise, multipath, and other degradations will need to be considered on an implementation by implementation basis in order to predict the overall performance of each individual system.

Figure 18 shows the curves for theoretical DBPSK/DQPSK demodulation with coherent demodulation and descrambling as well as the PRISM performance measured for DBPSK and DQPSK. The theoretical performance for DBPSK and DQPSK are the same as shown on the diagram. Figure 21 shows the theoretical and actual performance of the CCK modes. The losses in both figures include RF and IF radio losses; they do not reflect the ISL3873 losses alone. The ISL3873 baseband processing losses from theoretical are, by themselves, a small percentage of the overall loss.

The PRISM demodulator performs with an implementation loss of less than 4dB from theoretical in a AWGN environment with low phase noise local oscillators. For the 1 and 2Mbps modes, the observed errors occurred in groups of 4 and 6 errors. This is because of the error extension properties of differential decoding and descrambling. For the 5.5 and 11Mbps modes, the errors occur in symbols of 4 or 8 bits each and are further extended by the descrambling. Therefore the error patterns are less well defined.

Clock Offset Tracking Performance

The PRISM baseband processor is designed to accept data clock offsets of up to ± 25 ppm for each end of the link (TX and RX). This effects both the acquisition and the tracking performance of the demodulator. The budget for clock offset error is 0.75dB at ± 50 ppm. No appreciable degradation was seen for operation in AWGN at ± 50 ppm. Symbol tracking is accomplished by one of two methods. If both ends of the link employ locked oscillators for their bit timing and carrier frequency generation, symbol tracking is done by dividing down the carrier frequency offset. If either one of the ends of

the link do not have locked oscillators, then symbol tracking is done by a conventional early-late chip tracking method.

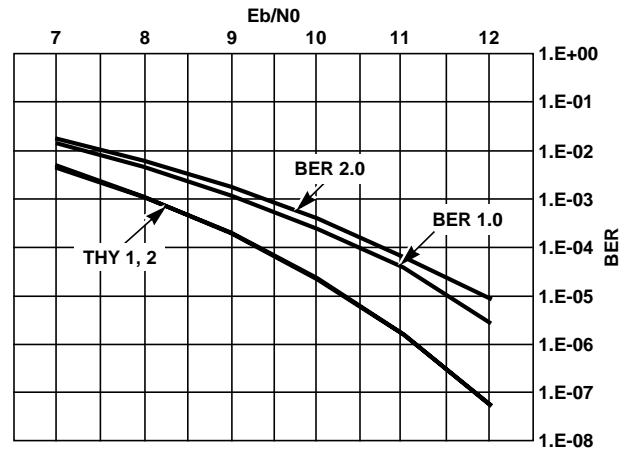

FIGURE 20. BER vs E_b/N_0 PERFORMANCE FOR PSK MODES

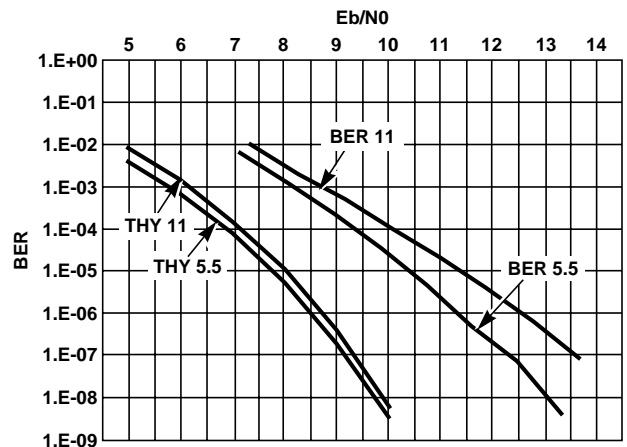

FIGURE 21. BER vs E_b/N_0 PERFORMANCE FOR CCK MODES

Carrier Offset Frequency Performance

The correlators used for acquisition for all modes and for demodulation in the 1 and 2Mbps modes are time invariant matched filter correlators otherwise known as parallel correlators. They use two samples per chip and are tapped at every other shift register stage. Their performance with carrier frequency offsets is determined by the phase roll rate due to the offset. For an offset of +50ppm (combined for both TX and RX) will cause the carrier to phase roll 22.5 degrees over the length of the correlator. This causes a loss of 0.22dB in correlation magnitude which translates directly to E_b/N_0 performance loss. In the PRISM chip design, the carrier phase locked loop is inactive during acquisition. During tracking, the carrier tracking loop corrects for offset, so that no degradation is noted. In the presence of high multipath and high SNR, however, some degradation is expected.

RSSI Performance

The RSSI value is reported on CR62 in hex and is linear with signal level in dB. Figure 22 shows the RSSI curve measured on a whole evaluation radio. This takes into account the full gain adjust range of all radio parts. To get signal level in dBm on a radio, simply subtract the RSSI value in decimal from 100.

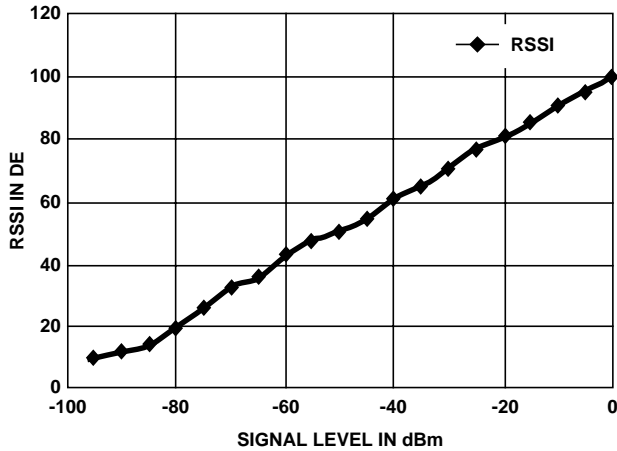

FIGURE 22. RSSI vs SIGNAL LEVEL

Signal Quality Estimate

A signal quality measure is available on CR51 for use by the MAC. This measure is the SNR in the carrier tracking loop and can be used to determine when the demodulator is working near to the noise floor and likely to make errors. Figure 23 shows the performance of the SQ measure versus signal to noise level.

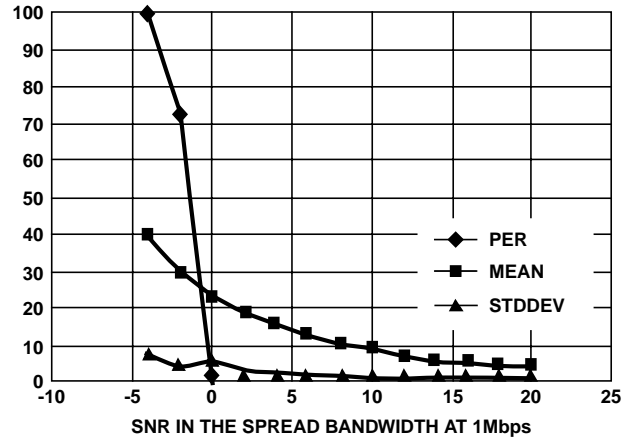

FIGURE 23. SIGNAL QUALITY MEASURE AND PER vs SNR

ED Threshold

The performance of the ED threshold is shown in Figure 24. Setting this threshold will effect CCA only. Using ED as part of the CCA measure will allow deferral to large signals even if they are not correlated to the desired spread signals.

ED can be read from CR61 bit 4. Using ED and RSSI can assist the MAC in determining the presence of non correlating signals such as frequency hoppers or microwave ovens. For example, the MAC can elect to try to transmit over microwave oven interference but not count the results in rate shifting algorithms.

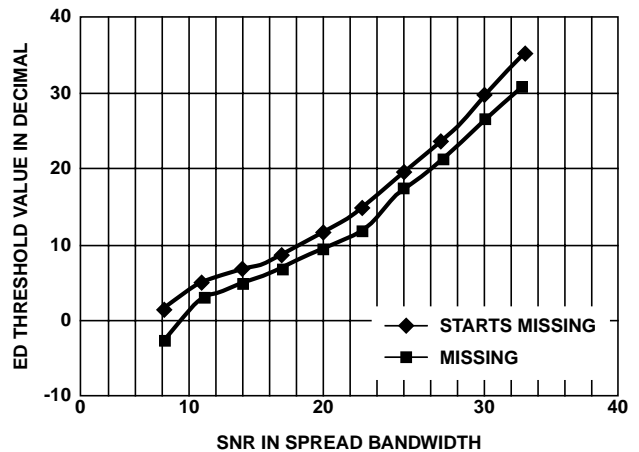
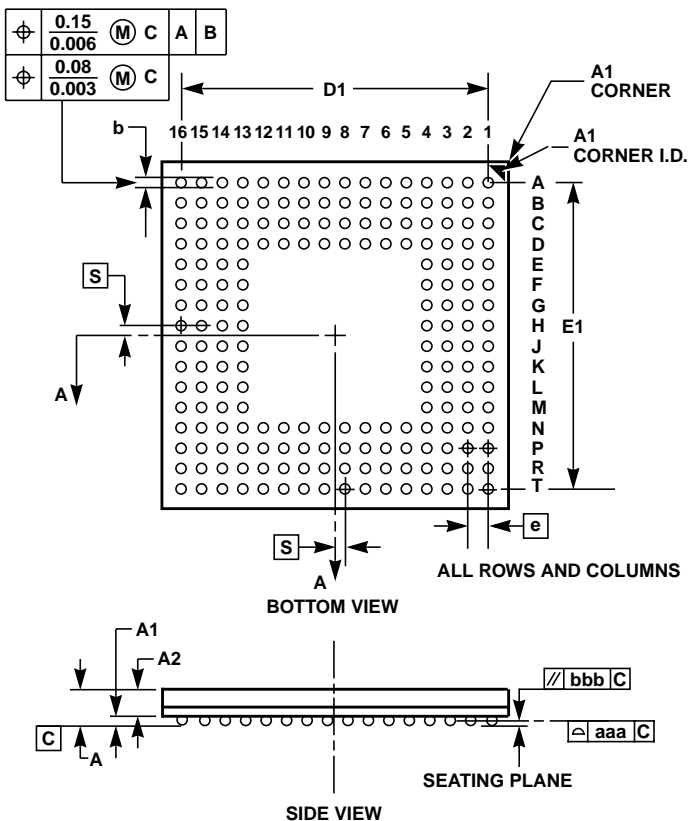
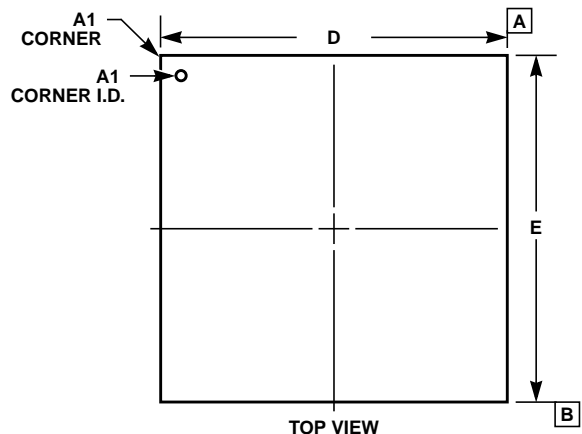

FIGURE 24. ED THRESHOLD vs SNR IN dB AT 1Mbps

Plastic Ball Grid Array Packages (BGA)



V192.14x14
192 BALL PLASTIC BALL GRID ARRAY PACKAGE

SYMBOL	INCHES		MILLIMETERS		NOTES
	MIN	MAX	MIN	MAX	
A	-	0.059	-	1.40	-
A1	0.012	0.016	0.31	0.41	-
A2	0.033	0.039	0.83	0.99	-
b	0.016	0.020	0.41	0.51	7
D/E	0.547	0.555	13.90	14.10	-
D1/E1	0.468	0.476	11.90	12.10	-
N	192		192		-
e	0.032 BSC		0.80 BSC		-
MD/ME	16 x 16		16 x 16		3
bbb	0.004		0.10		-
aaa	0.005		0.12		-

Rev. 1 1/01

NOTES:

1. Controlling dimension: MILLIMETER. Converted inch dimensions are not necessarily exact.
2. Dimensioning and tolerancing conform to ASME Y14.5M-1994.
3. "MD" and "ME" are the maximum ball matrix size for the "D" and "E" dimensions, respectively.
4. "N" is the maximum number of balls for the specific array size.
5. Primary datum C and seating plane are defined by the spherical crowns of the contact balls.
6. Dimension "A" includes standoff height "A1", package body thickness and lid or cap height "A2".
7. Dimension "b" is measured at the maximum ball diameter, parallel to the primary datum C.
8. Pin "A1" is marked on the top and bottom sides adjacent to A1.
9. "S" is measured with respect to datum's A and B and defines the position of the solder balls nearest to package centerlines. When there is an even number of balls in the outer row the value is "S" = e/2.

All Intersil products are manufactured, assembled and tested utilizing ISO9000 quality systems.

Intersil Corporation's quality certifications can be viewed at website www.intersil.com/quality/iso.asp.

Intersil products are sold by description only. Intersil Corporation reserves the right to make changes in circuit design and/or specifications at any time without notice. Accordingly, the reader is cautioned to verify that data sheets are current before placing orders. Information furnished by Intersil is believed to be accurate and reliable. However, no responsibility is assumed by Intersil or its subsidiaries for its use; nor for any infringements of patents or other rights of third parties which may result from its use. No license is granted by implication or otherwise under any patent or patent rights of Intersil or its subsidiaries.

For information regarding Intersil Corporation and its products, see web site www.intersil.com

Sales Office Headquarters

NORTH AMERICA
Intersil Corporation
2401 Palm Bay Rd., Mail Stop 53-204
Palm Bay, FL 32905
TEL: (321) 724-7000
FAX: (321) 724-7240

EUROPE
Intersil SA
Mercure Center
100, Rue de la Fusee
1130 Brussels, Belgium
TEL: (32) 2.724.2111
FAX: (32) 2.724.22.05

ASIA
Intersil Ltd.
8F-2, 96, Sec. 1, Chien-kuo North,
Taipei, Taiwan 104
Republic of China
TEL: 886-2-2515-8508
FAX: 886-2-2515-8369