

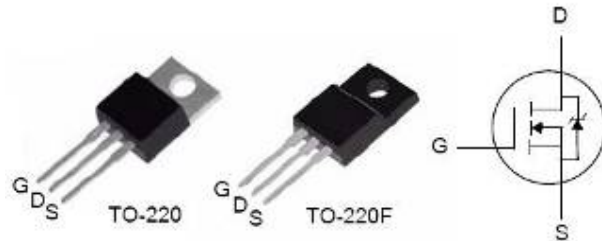
**500V N-Channel MOSFET**
**General Features**

- Low ON Resistance
- Low Gate Charge (typical 33nC)
- Fast Switching
- 100% Avalanche Tested
- RoHS Compliant/Lead Free

|            |                     |       |
|------------|---------------------|-------|
| $BV_{DSS}$ | $R_{DS(ON)}$ (Max.) | $I_D$ |
| 500V       | 0.9Ω                | 8.0A  |

**Applications**

- High Efficiency SMPS
- Adaptor/Charger
- Active PFC
- LCD Panel Power


**Ordering Information**

| Part Number | Package | Marking  |
|-------------|---------|----------|
| FTP08N50    | TO-220  | FTP08N50 |
| FTA08N50    | TO-220F | FTA08N50 |

**Absolute Maximum Ratings**
 $T_C=25^{\circ}\text{C}$  unless otherwise specified

| Symbol                      | Parameter  | FTP08N50   | FTA08N50 | Unit |
|-----------------------------|--|------------|----------|------|
| $V_{DSS}$                   | Drain-to-Source Voltage <sup>[1]</sup>                           | 500        |          | V    |
| $I_D$                       | Continuous Drain Current   | 8.0        | 8.0*     | A    |
| $I_{D@100^{\circ}\text{C}}$ | Continuous Drain Current   | Figure 3   |          |      |
| $I_{DM}$                    | Pulsed Drain Current, $V_{GS}@10\text{V}^{[2]}$                  | Figure 6   |          |      |
| $P_D$                       | Power Dissipation  | 125        | 31       | W    |
|                             | Derating Factor above 25°C                                       | 1.0        | 0.25     | W/°C |
| $V_{GS}$                    | Gate-to-Source Voltage   | ±30        |          | V    |
| $E_{AS}$                    | Single Pulse Avalanche Energy $L=7\text{mH}$ , $I_D=8.0\text{A}$ | 220        |          | mJ   |
| dv/dt                       | Peak Diode Recovery dv/dt <sup>[3]</sup>                         | 4.5        |          | V/ns |
| $T_L$                       | Soldering Temperature  | 300        |          | °C   |
|                             | Distance of 1.6mm from case for 10 seconds                       |            |          |      |
| $T_J$ and $T_{STG}$         | Operating and Storage Temperature Range                          | -55 to 150 |          |      |

\*Drain Current limited by Maximum Junction Temperature.

Caution: Stresses greater than those listed in the "Absolute Maximum Ratings" may cause permanent damage to the device.

**Thermal Characteristics**

| Symbol          | Parameter                               | FTP08N50 | FTA08N50 | Unit |
|-----------------|---|----------|----------|------|
| $R_{\theta JC}$ | Thermal Resistance, Junction-to-Case    | 1.0      | 4.0      | °C/W |
| $R_{\theta JA}$ | Thermal Resistance, Junction-to-Ambient | 60       | 60       |      |



**Electrical Characteristics**

**OFF Characteristics**

$T_C = 25^\circ\text{C}$  unless otherwise specified

| Symbol                       | Parameter                                 | Min. | Typ. | Max. | Unit                | Test Conditions                                      |
|------------------------------|---|------|------|------|---------------------|--|
| $BV_{DSS}$                   | Drain-to-Source Breakdown Voltage         | 500  | --   | --   | V                   | $V_{GS}=0V, I_D=250\mu A$                            |
| $\Delta BV_{DSS}/\Delta T_J$ | Breakdown Voltage Temperature Coefficient | --   | 0.6  | --   | V/ $^\circ\text{C}$ | Reference to $25^\circ\text{C}$ ,<br>$I_D=250\mu A$  |
| $I_{DSS}$                    | Drain-to-Source Leakage Current           | --   | --   | 12   | $\mu A$             | $V_{DS}=500V, V_{GS}=0V$                             |
|                              |   | --   | --   | 100  |                     | $V_{DS}=400V, V_{GS}=0V,$<br>$T_C=125^\circ\text{C}$ |
| $I_{GSS}$                    | Gate-to-Source Leakage Current            | --   | --   | 100  | nA                  | $V_{GS}=+30V$  |
|                              |   | --   | --   | -100 |                     | $V_{GS}=-30V$  |

**ON Characteristics**

$T_C = 25^\circ\text{C}$  unless otherwise specified

| Symbol       | Parameter                            | Min. | Typ. | Max. | Unit     | Test Conditions                 |
|--------------|--------------------------------------|------|------|------|----------|---------------------------------|
| $R_{DS(ON)}$ | Static Drain-to-Source On-Resistance | --   | 0.75 | 0.9  | $\Omega$ | $V_{GS}=10V, I_D=4.8A^{[4]}$    |
| $V_{GS(TH)}$ | Gate Threshold Voltage               | 2.0  | --   | 4.0  | V        | $V_{DS} = V_{GS}, I_D=250\mu A$ |
| gfs          | Forward Transconductance             | --   | 7.9  | --   | S        | $V_{DS} = 15V, I_D=8.0A^{[4]}$  |

**Dynamic Characteristics**

Essentially independent of operating temperature

| Symbol    | Parameter                     | Min. | Typ. | Max. | Unit | Test Conditions  |
|-----------|-------------------------------|------|------|------|------|--|
| $C_{ISS}$ | Input Capacitance             | --   | 1110 | --   | pF   | $V_{GS}=0V$<br>$V_{DS}=25V$<br>$f=1.0MHz$<br>Figure 14 |
| $C_{OSS}$ | Output Capacitance            | --   | 101  | --   |      |  |
| $C_{RSS}$ | Reverse Transfer Capacitance  | --   | 21   | --   |      |  |
| $Q_G$     | Total Gate Charge             | --   | 33   | --   | nC   | $V_{DD}=250V$<br>$I_D=8.0A$<br>Figure 15               |
| $Q_{GS}$  | Gate-to-Source Charge         | --   | 3.2  | --   |      |  |
| $Q_{GD}$  | Gate-to-Drain (Miller) Charge | --   | 12.5 | --   |      |  |

**Resistive Switching Characteristics**

Essentially independent of operating temperature

| Symbol       | Parameter           | Min. | Typ. | Max. | Unit | Test Conditions   |
|--------------|---------------------|------|------|------|------|---|
| $t_{d(ON)}$  | Turn-on Delay Time  | --   | 31   | --   | ns   | $V_{DD}=250V$<br>$I_D=8.0A$<br>$V_{GS}=10V$<br>$R_G=20\Omega$ |
| $t_{rise}$   | Rise Time           | --   | 72   | --   |      |   |
| $t_{d(OFF)}$ | Turn-off Delay Time | --   | 74   | --   |      |   |
| $t_{fall}$   | Fall Time           | --   | 51   | --   |      |   |

**Source-Drain Diode Characteristics**
 $T_c=25^\circ\text{C}$  unless otherwise specified

| Symbol   | Parameter                              | Min | Typ. | Max. | Units | Test Conditions   |
|----------|--|-----|------|------|-------|---|
| $I_{SD}$ | Continuous Source Current (Body Diode) | --  | --   | 8.0  | A     | Integral P-N diode in MOSFET  |
| $I_{SM}$ | Maximum Pulsed Current (Body Diode)    | --  | --   | 32   | A     |   |
| $V_{SD}$ | Diode Forward Voltage                  | --  | --   | 1.2  | V     | $I_S=8.0\text{A}$ , $V_{GS}=0\text{V}$                                    |
| $t_{rr}$ | Reverse Recovery Time                  | --  | 320  | --   | ns    | $V_{GS}=0\text{V}$<br>$I_F=8.0\text{A}$ , $di/dt=100\text{A}/\mu\text{s}$ |
| $Q_{rr}$ | Reverse Recovery Charge                | --  | 1980 | --   | nC    |   |

**NOTE:**

[1]  $T_J=+25^\circ\text{C}$  to  $+150^\circ\text{C}$

[2] Repetitive rating, pulse width limited by maximum junction temperature.

[3]  $I_{SD}=8.0\text{A}$ ,  $di/dt \leq 100\text{A}/\mu\text{s}$ ,  $V_{DD} \leq BV_{DSS}$ ,  $T_J=+150^\circ\text{C}$

[4] Pulse width  $\leq 380\mu\text{s}$ ; duty cycle  $\leq 2\%$ .

Figure 1. Maximum Effective Thermal Impedance, Junction-to-Case

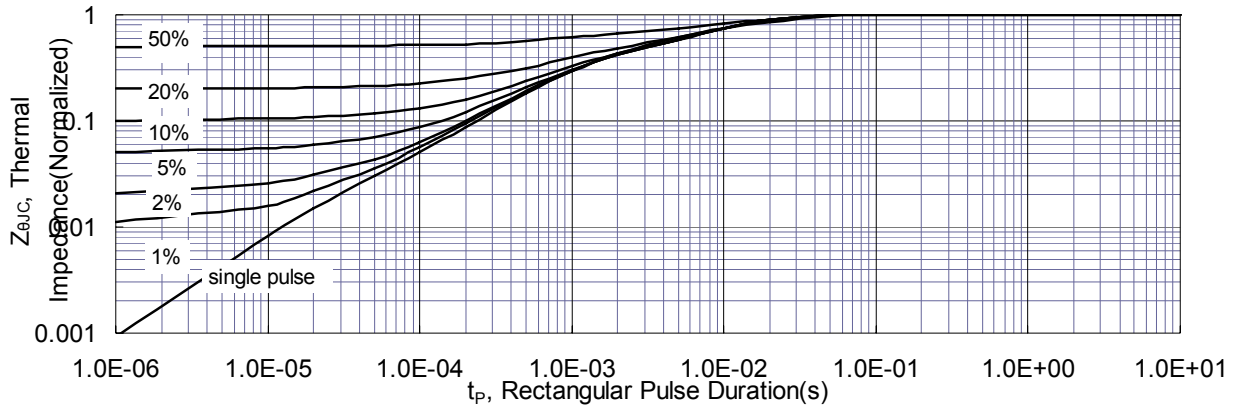


Figure 2. Maximum Power Dissipation vs. Case Temperature

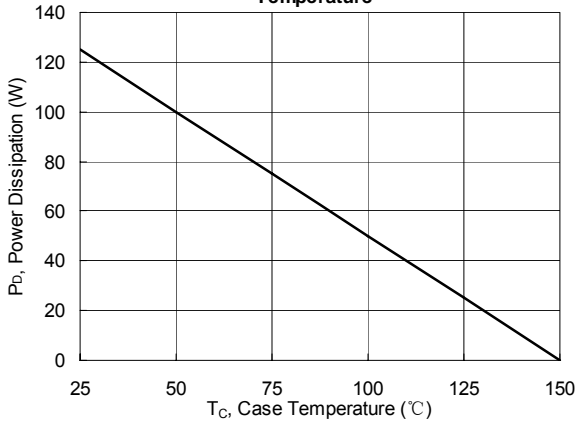


Figure 3. Maximum Continuous Drain Current vs. Case Temperature

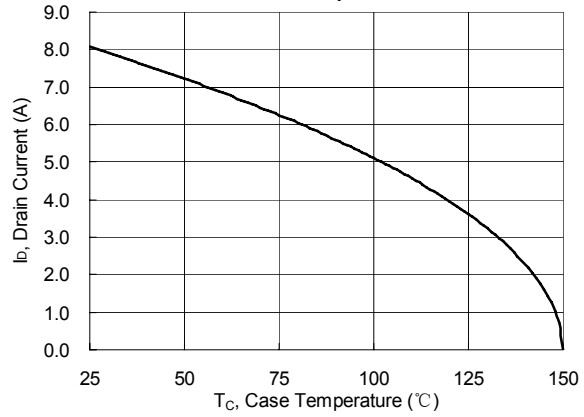


Figure 4. Typical Output Characteristics

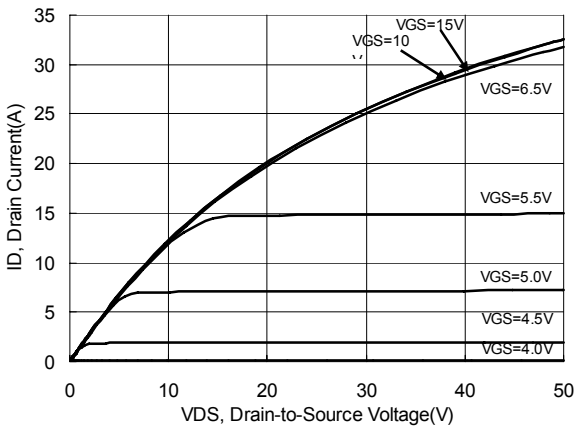
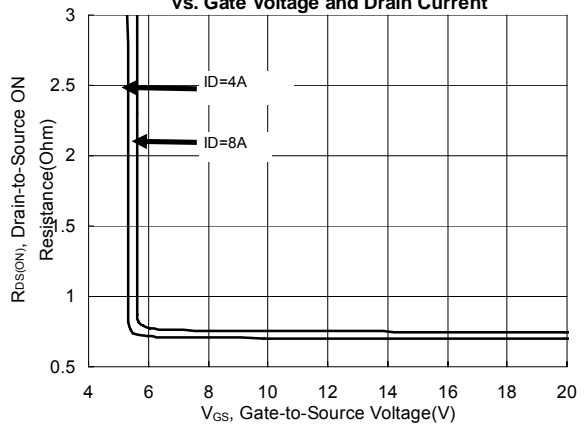
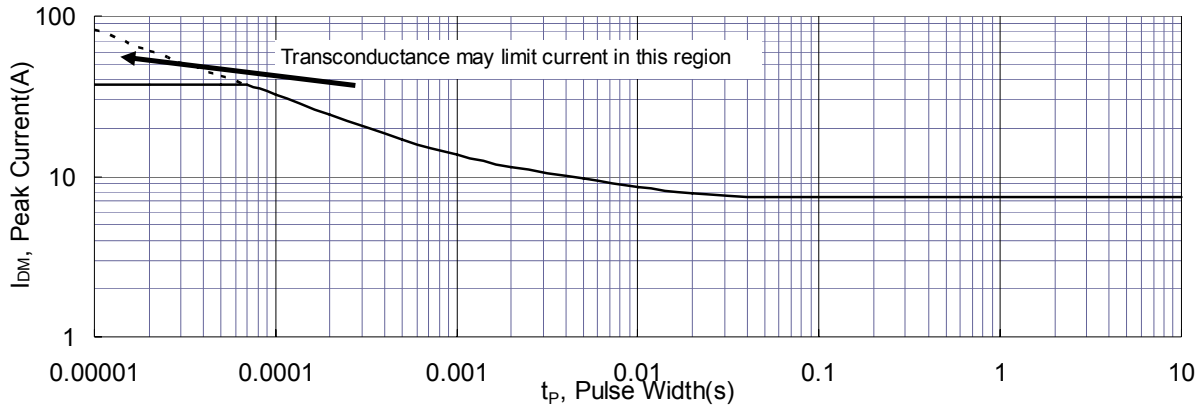
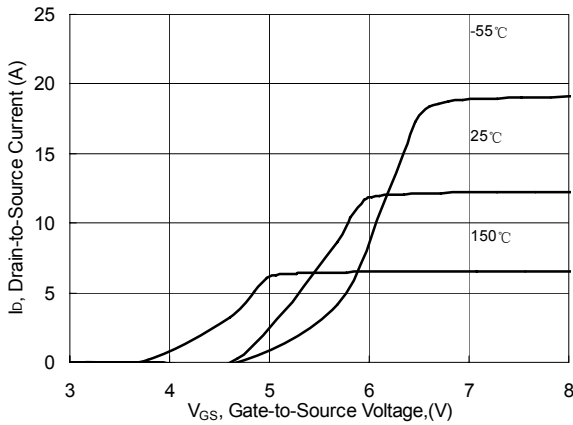
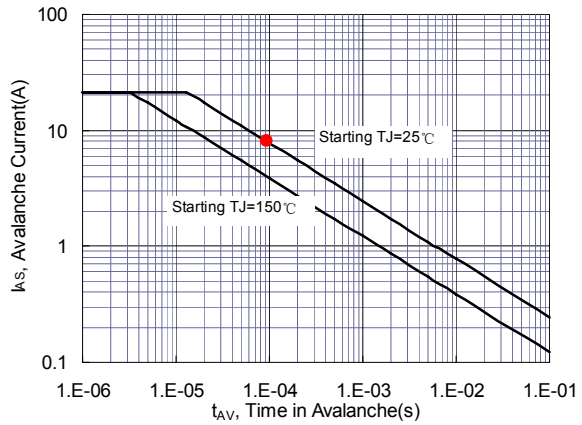
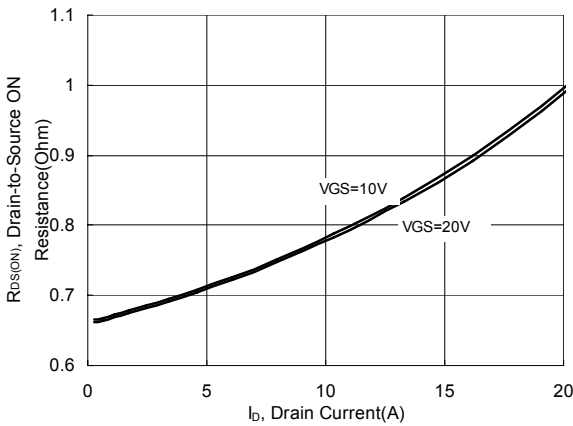
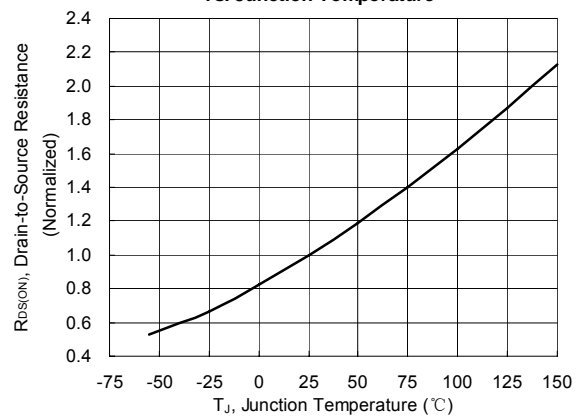
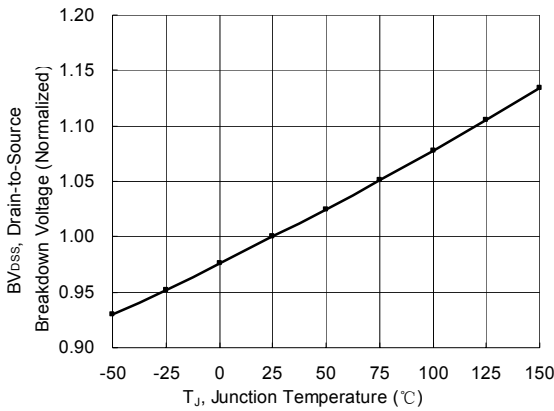


Figure 5. Typical Drain-to-Source ON Resistance vs. Gate Voltage and Drain Current

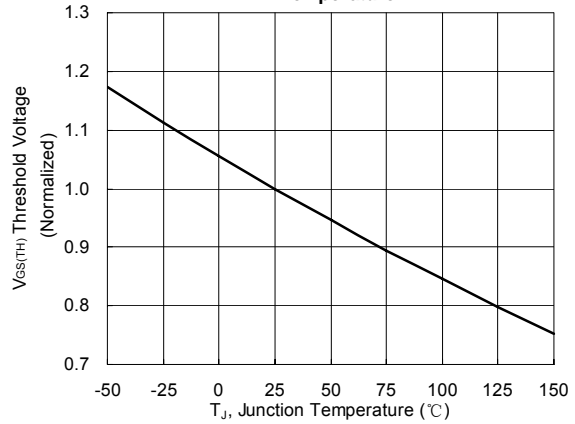


**Figure 6. Maximum Peak Current Capability**

**Figure 7. Typical Transfer Characteristics**

**Figure 8. Unclamped Inductive Switching Capability**

**Figure 9. Typical Drain-to-Source ON Resistance**

**Figure 10. Typical Drain-to-Source On Resistance vs. Junction Temperature**


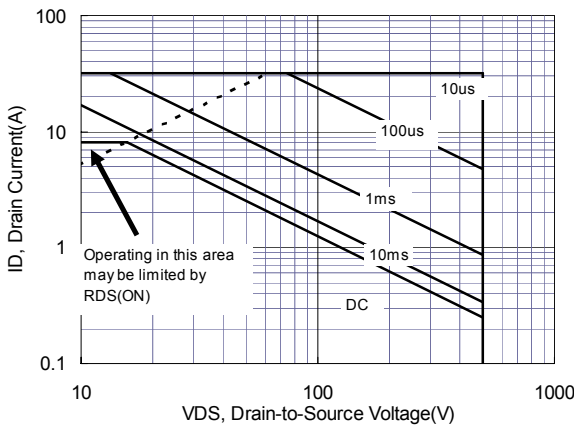
**Figure 11. Typical Breakdown Voltage vs. Junction Temperature**



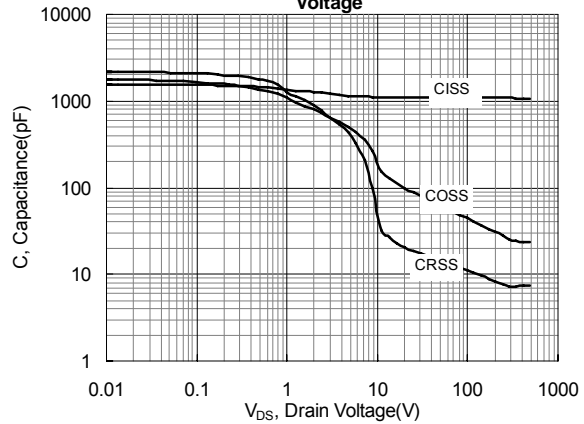
**Figure 12. Typical Threshold Voltage vs. Junction Temperature**



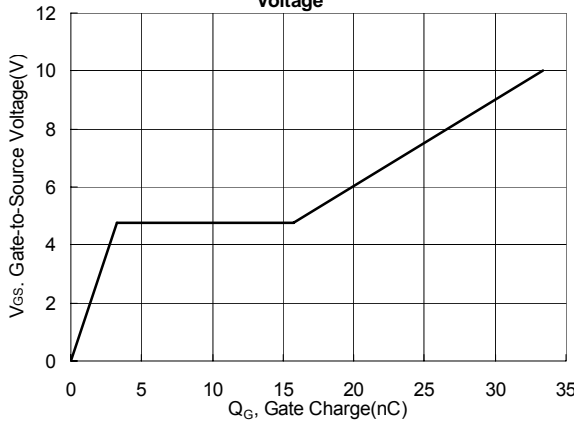
**Figure 13. Maximum Forward Safe Operation Area**



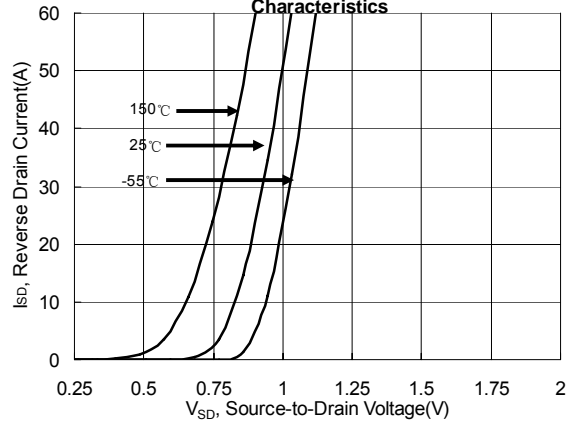
**Figure 14. Typical Capacitance vs. Drain-to-Source Voltage**



**Figure 15. Typical Gate Charge vs. Gate-to-Source Voltage**



**Figure 16. Typical Body Diode Transfer Characteristics**



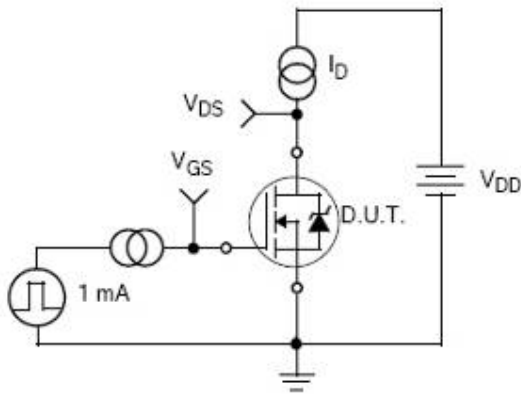
**Test Circuit**


Figure 17. Gate Charge Test Circuit

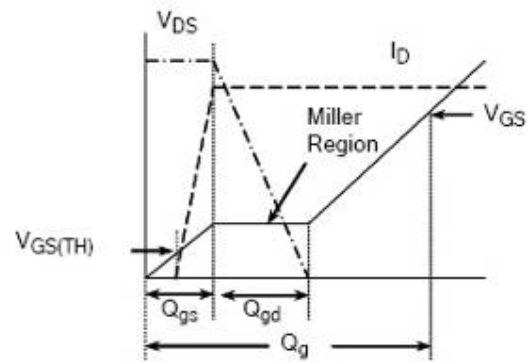


Figure 18. Gate Charge Waveform

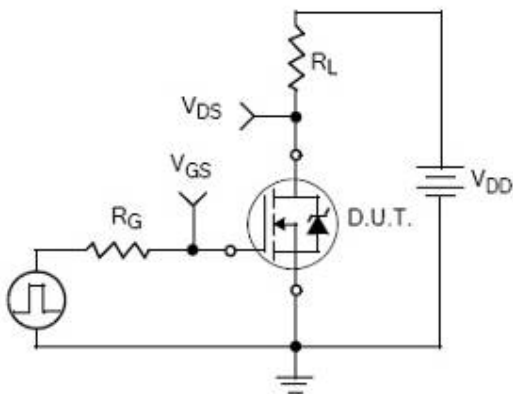


Figure 19. Resistive Switching Test Circuit

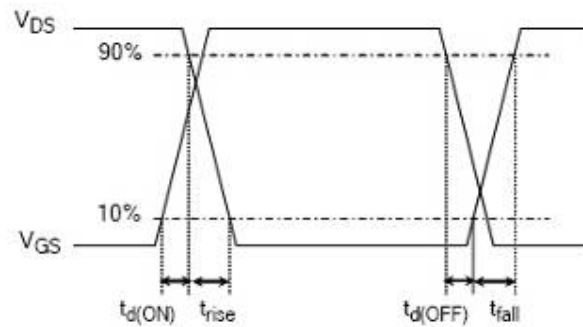


Figure 20. Resistive Switching Waveforms

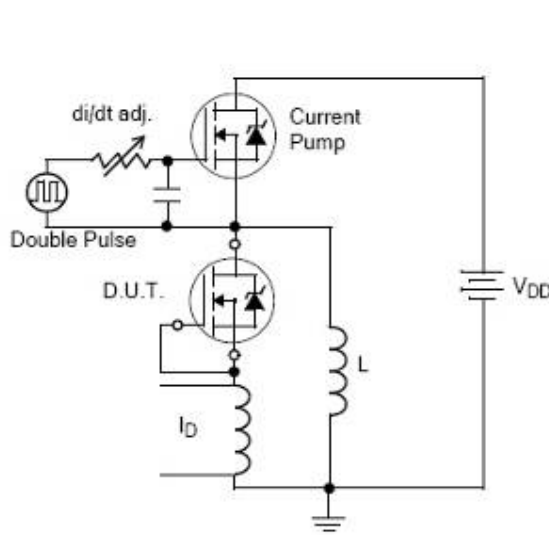


Figure 21. Diode Reverse Recovery Test Circuit

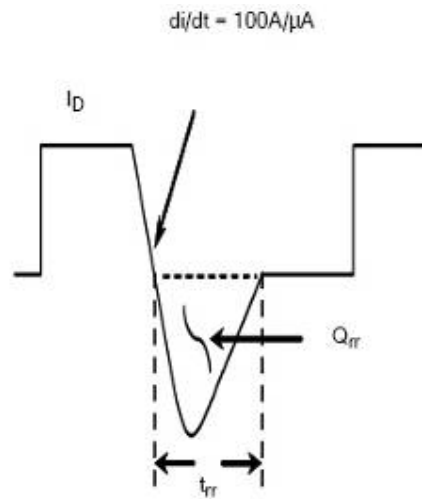


Figure 22. Diode Reverse Recovery Waveform

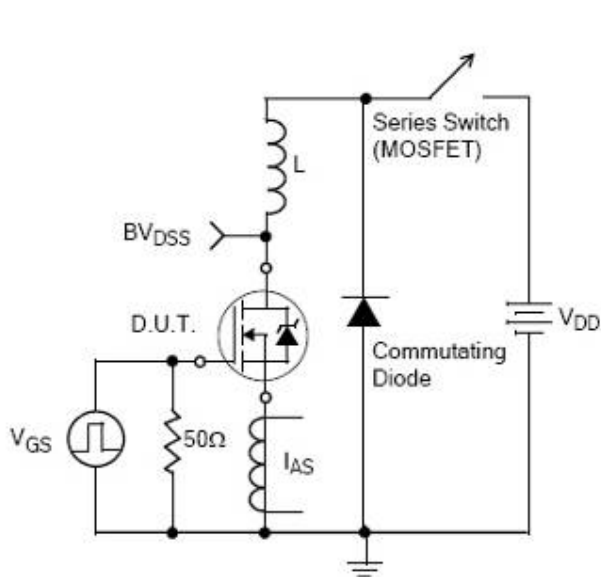


Figure 23. Unclamped Inductive Switching Test Circuit

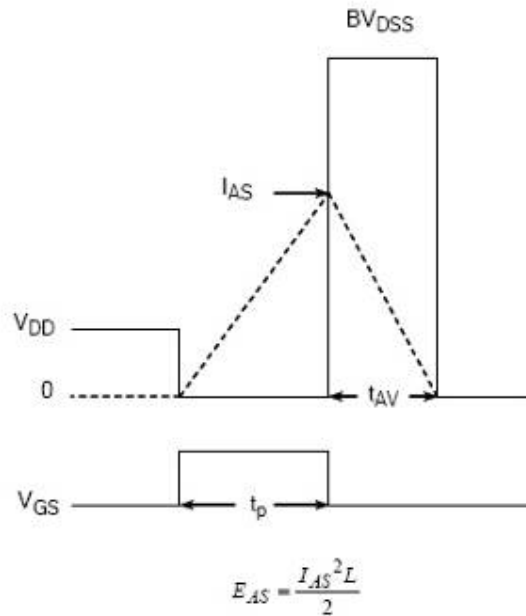
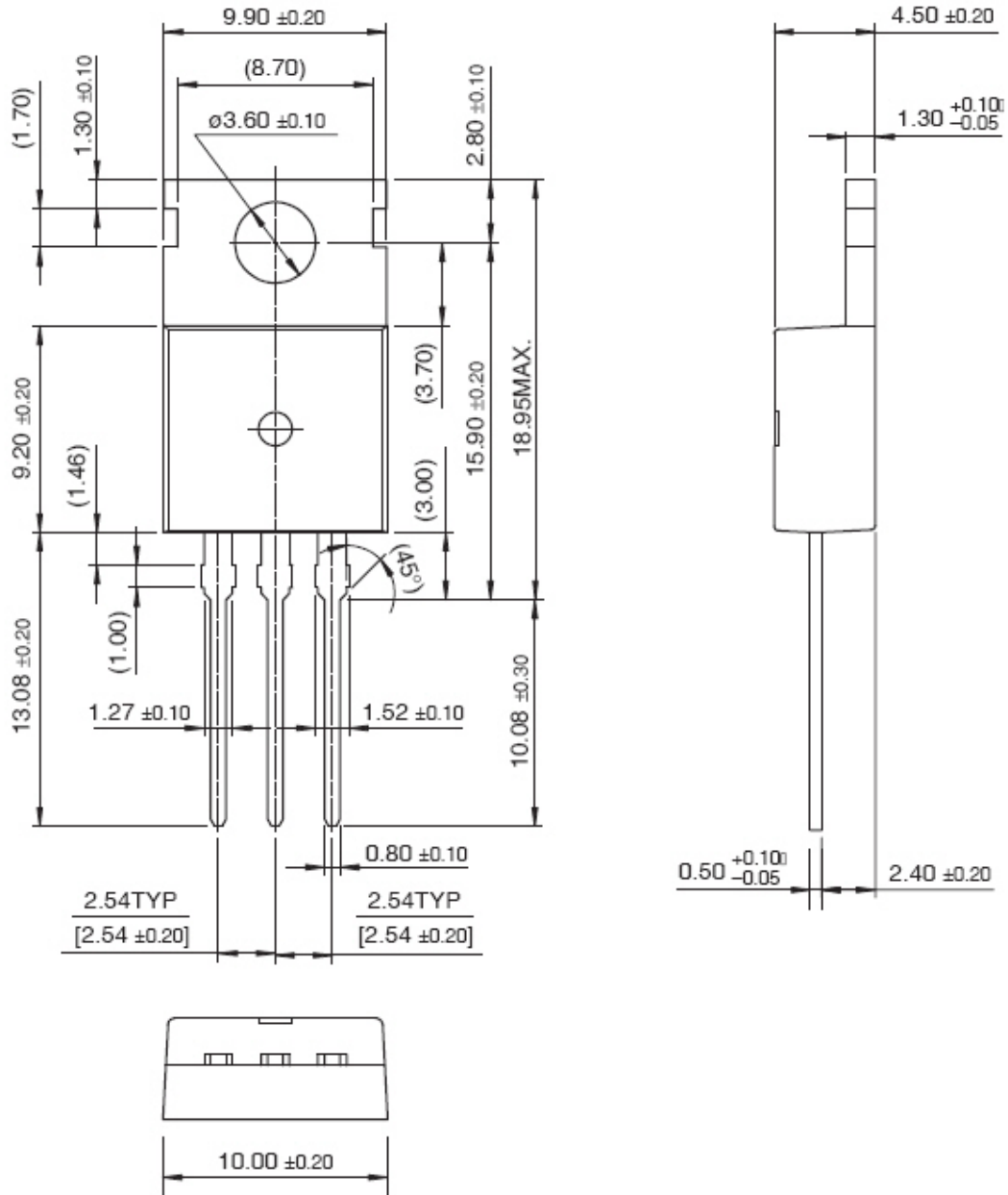
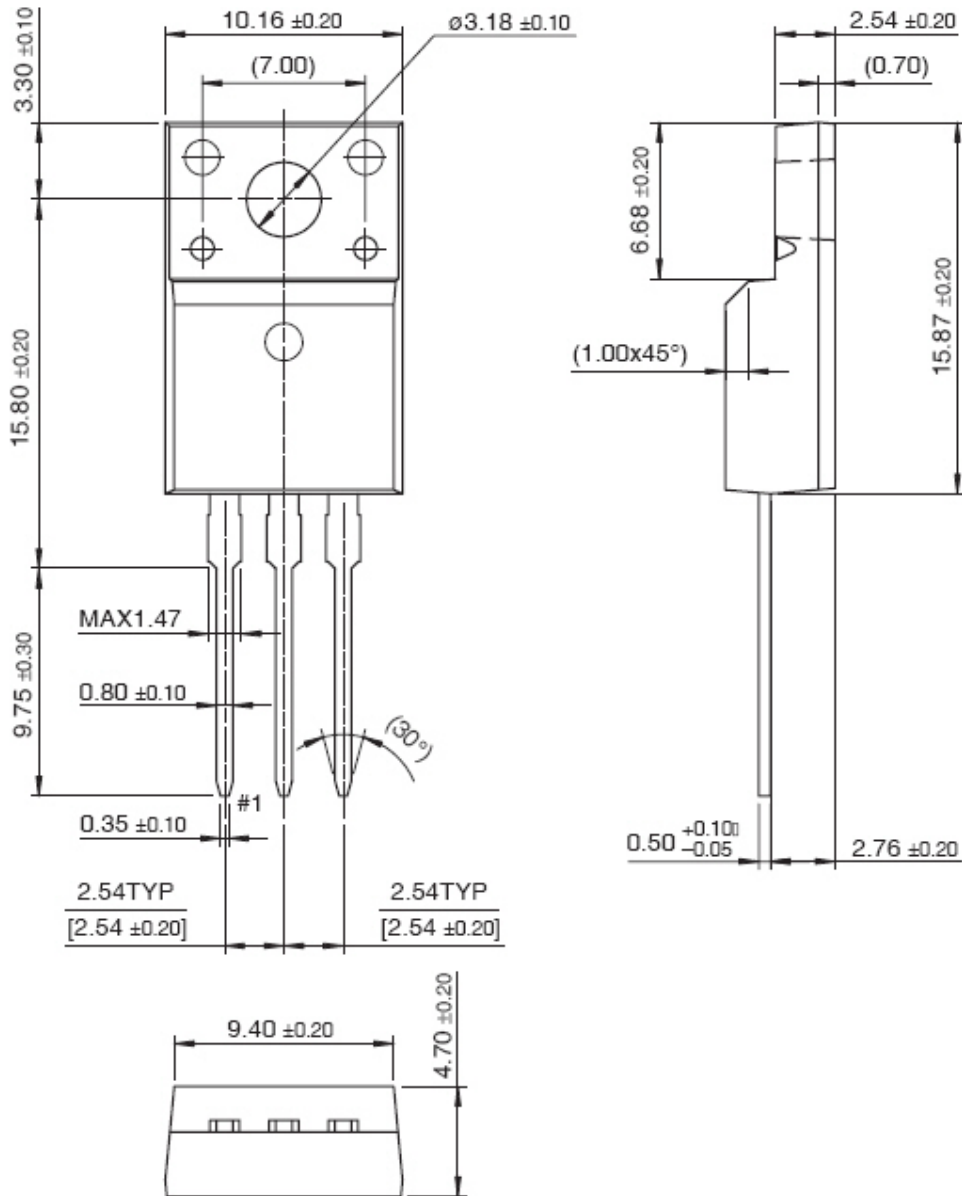


Figure 24. Unclamped Inductive Switching Waveforms



**Package Dimensions**
**TO-220**


**TO-220F**




**Published by**  
**ARK Microelectronics Co., Ltd.**  
**No.9, East Zijing Road, High-tek District, Chengdu, P. R. China**  
**All Rights Reserved.**

## **Disclaimers**

---

ARK Microelectronics Co., Ltd. reserves the right to make change without notice in order to improve reliability, function or design and to discontinue any product or service without notice. Customers should obtain the latest relevant information before orders and should verify that such information is current and complete. All products are sold subject to ARK Microelectronics Co., Ltd's terms and conditions supplied at the time of order acknowledgement.

ARK Microelectronics Co., Ltd. warrants performance of its hardware products to the specifications at the time of sale, Testing, reliability and quality control are used to the extent ARK Microelectronics Co., Ltd deems necessary to support this warrantee. Except where agreed upon by contractual agreement, testing of all parameters of each product is not necessary performed.

ARK Microelectronics Co., Ltd. does not assume any liability arising from the use of any product or circuit designs described herein. Customers are responsible for their products and applications using ARK Microelectronics Co., Ltd's components. To minimize risk, customers must provide adequate design and operating safeguards.

ARK Microelectronics Co., Ltd. does not warrant or convey any license either expressed or implied under its patent rights, nor the rights of others. Reproduction of information in ARK Microelectronics Co., Ltd's data sheets or data books is permissible only if reproduction is without modification or alteration. Reproduction of this information with any alteration is an unfair and deceptive business practice. ARK Microelectronics Co., Ltd is not responsible or liable for such altered documentation.

Resale of ARK Microelectronics Co., Ltd's products with statements different from or beyond the parameters stated by ARK Microelectronics Co., Ltd. for the product or service voids all express or implied warranties for the associated ARK Microelectronics Co., Ltd's product or service and is unfair and deceptive business practice. ARK Microelectronics Co., Ltd is not responsible or liable for any such statements.

---

## **Life Support Policy:**

ARK Microelectronics Co., Ltd's products are not authorized for use as critical components in life devices or systems without the expressed written approval of ARK Microelectronics Co., Ltd.

As used herein:

1. Life support devices or systems are devices or systems which:
    - a. are intended for surgical implant into the human body,
    - b. support or sustain life,
    - c. whose failure to perform when properly used in accordance with instructions for used provided in the labeling, can be reasonably expected to result in significant injury to the user.
  2. A critical component is any component of a life support device or system whose failure to perform can be reasonably expected to cause the failure of the life support device or system, or to affect its safety or effectiveness.
-