



INDUSTRIAL RELAYS

UL & CUL File #E223388

FEATURES

1. Specifically designed for thermostat, modem, computer peripherals, video recording, and security applications.
2. Designed for high density PCB.
3. High sensitivity 150mW.

ORDERING INFORMATION

SA 1C - 12 H S
(1) (2) (3) (4) (5)

- | | |
|---|---|
| <p>(1) Basic Designation
SA = SA Series</p> <p>(2) Contact Arrangement
1A = 1 Form A (SPST-NO)
1C = 1 Form C (SPDT)</p> <p>(3) Coil Voltage
2V~24V</p> | <p>(4) Coil Sensitivity
Nil = 0.2W
H = 0.15W</p> <p>(5) Enclosure
Nil = Unsealed type
S = Sealed type</p> |
|---|---|

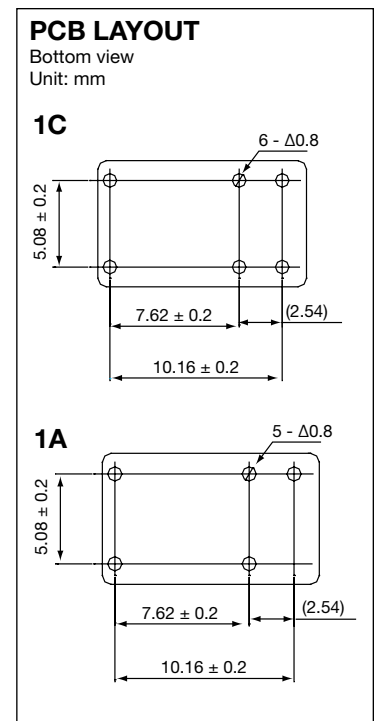
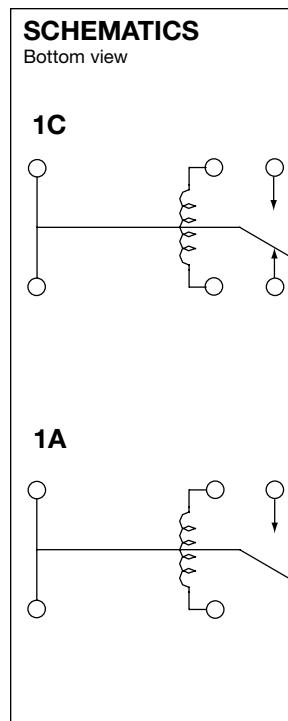
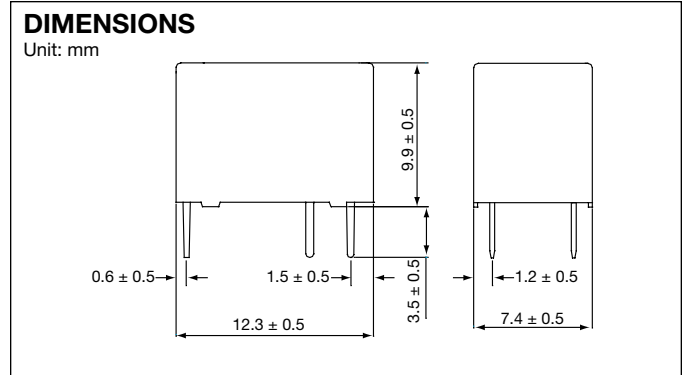

COIL RATINGS (AT 20°C)

Coil Type	Coil Nominal Voltage (VDC)	Coil Resistance Ω (± 10%)	Pick-Up Voltage (VDC) max.	Drop-Out Voltage (VDC) min.	Max. Allowable Voltage
Coil Sensitivity H = 0.15W	2	26.7	1.50	0.10	140% of nominal voltage
	3	60.0	2.25	0.15	
	5	166	3.75	0.25	
	6	240	4.50	0.30	
	9	540	6.75	0.45	
	12	960	9.00	0.60	
Coil Sensitivity Nil = 0.2W	24	3840	18.0	1.20	115% of nominal voltage
	2	20.0	1.50	0.10	
	3	45.0	2.25	0.15	
	5	125	3.75	0.25	
	6	180	4.50	0.30	
	9	405	6.75	0.45	
	12	720	9.00	0.60	
	24	2880	18.0	1.20	



CONTACT RATINGS

Contact Arrangement	1C; 1A
Nominal Operating Power	0.15W, 0.2W
Max. Switching Power	6135VA 30W
Max. Switching Voltage	125VAC 30VDC
Max. Switching Current	1A
Contact Resistance (By voltage drop 6V 1A)	100mΩ max.
UL/ C-UL Resistive Load (cos Ø = 1)	1A / 120VAC 1A / 30VDC
Contact Material	silver alloy

CHARACTERISTICS

Electrical Life (at 20cpm)	1 x 10 ⁵
Mechanical Life (at 120cpm)	5 x 10 ⁷
Initial Insulation Resistance	Min. 100MΩ 500VDC
Operate Time	5ms max.
Release Time	5ms max.
Initial Breakdown Voltage	50/60Hz 500VAC 1 min. (between open contacts) 50/60Hz 1000VAC 1 min. (between coil & contact)
Vibration Resistance	Functional: 10 to 55Hz at double Amplitude of 1.5mm Destructive: 10 to 55Hz at double Amplitude of 1.5mm
Shock Resistance	Functional: Min. 10G Destructive: Min. 50G
Ambient Temperature	-40°C ~ +80°C
Operating Humidity	45 to 85% RH
Unit Weight	Approx. 3g

REFERENCE DATA

Coil Temperature Rise

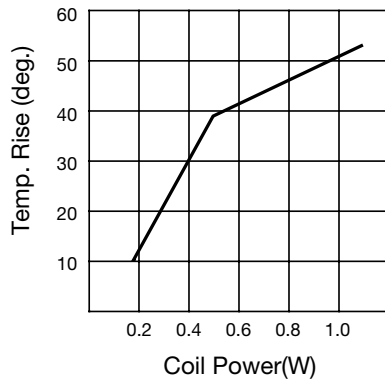

Operate Time/ Release Time

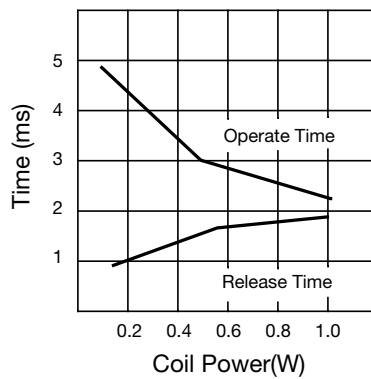

Life Expectancy

