

## High-speed Fiber Optic: SA1C-F

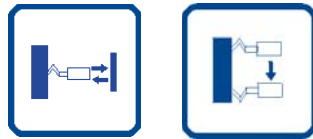

- Ideal for remote sensing applications
- Featuring quick-connect cable and easy-insert fiber optic units for simple installation
- Through-beam and reflected-light sensing available
- Sensing range up to 7.09" (180mm) for through-beam sensors
- Dual outputs: Select NPN and PNP transistor outputs or NPN transistor output combined with a self-diagnostic output
- Outputs selectable for light on or dark on
- High-speed, 50 $\mu$ s response time
- Featuring variable off-delay (0 to 100msec) and fine-tune sensitivity adjustment
- Stable LED makes alignment easy
- Red or green LEDs available for detecting color marks
- Mount on a 35mm DIN rail

The perfect fiber optic sensor for applications where you have difficulty mounting regular or miniature sensors or where accessibility is a problem.

Available in through-beam and retro-reflective models, the built-in variable off-delay (0 - 10ms) can help you bring your complete system in tune.

The 50 $\mu$ s response time ensures detection of fast moving targets in a high-speed manufacturing environment where speed counts.

Dimensions (mm)

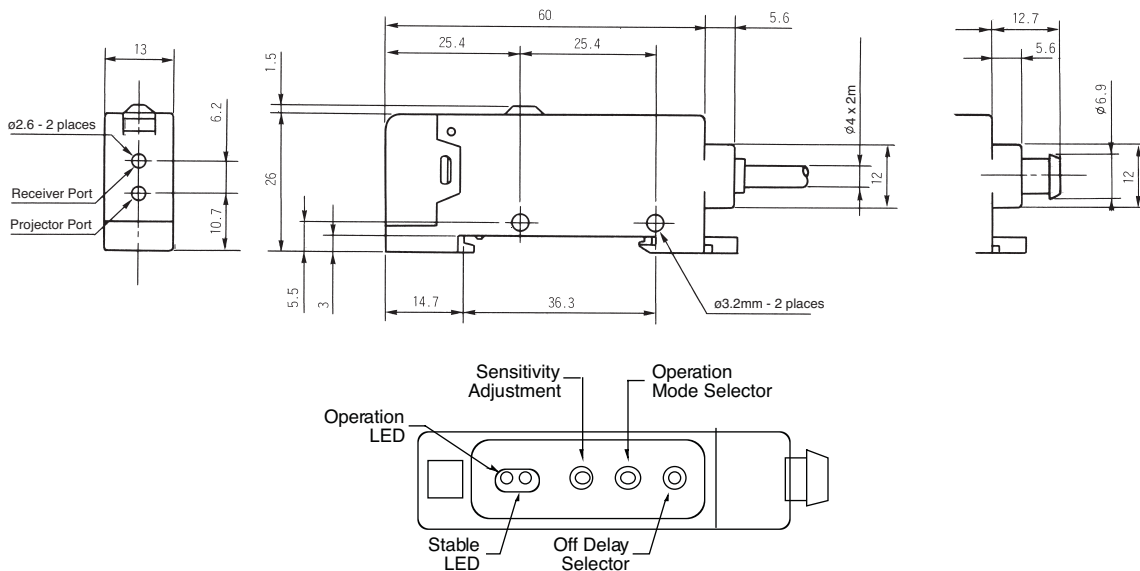

Specifications

		SA1C-FN, -FD (Standard Speed)	SA1C-F1N, -F1D (High-speed)	
General Specifications	<b>Power Voltage</b>	12V to 24V DC	√	
	<b>Operating Voltage</b>	10V to 30V DC, ripple 10% (maximum)	√	
	<b>Current Draw</b>	30mA (maximum)	√	—
		40mA (maximum)	—	√
	<b>Operating Temperature</b>	Amplifier only: -25° to +55°C	√	√
		Fiber optic cords (except heat-resistant types): -40° to +70°C Heat-resistant fiber optic cords: -40°C to +350°C (avoid ice coating)		
	<b>Operating Humidity</b>	35 to 85% RH (avoid condensation)	√	√
	<b>Extraneous Light Immunity</b>	Sunlight: 10,000 lux (maximum); Incandescent light: 3,000 lux (maximum) on receiver surface— defined as incident or unwanted light received by a sensor, unrelated to the presence or absence of the intended object	√	√
	<b>Material</b>	Amplifier only: PBT resin (housing) with polycarbonate lens Fiber optic cords (except heat-resistant types): Nickel-plated brass (sensing head), polyethylene-covered PMMA (cord), and SUS304 stainless (sleeve) Heat-resistant fiber optic cords: SUS 304 stainless (sensing head) and SUS spiral tube around glass fiber cord	√	√
	<b>Degree of Protection</b>	IP66 — IEC Pub 529, sensors rated IP66 are dust-tight, water-resistant, and perform best when not subjected to heavy particle or water blasts	√	√
	<b>Cable</b>	Cable type: 0.2mm <sup>2</sup> ; Vinyl cable #24 AWG, 6'-6-3/4' (2m) long Connector type: Ø 0.31" (8mm) 3- or 4-pin connector (cable ordered separately for quick connect sensors)	√	√
	<b>Light Source</b>	Red or green LED (pulse-modulated)	√	√
	<b>Output</b>	NPN transistor: 30V DC (1.2V residual), 100mA (maximum)	√	√
		PNP transistor: 30V DC (2.0V residual), 200mA (maximum) Self-diagnostic: 30V DC (1.2V residual), 50mA (maximum)		
<b>Response</b>	0.5ms (maximum)	√	—	
	50µs (maximum)	—	√	
<b>Off Delay</b>	0 to 100 ms (adjustable)	√	√	
<b>Sensitivity</b>	4-turn adjustment	√	√	
<b>Minimum Bending Radius</b>	Fiber optic cord (except SA9F-TT, -DT, -TL, and -DL): 1"R (25mm); Sleeve: 0.39"R (10mm) SA9F-TT and -DT: 0.59"R (15mm); Sleeve: 0.39"R (10mm) SA9F-TL and DL: 0.59"R (15mm); Sleeve: Unbendable	√	√	



			SA1C-FN, -FD (Standard Speed)	SA1C-F1N, -F1D (High-speed)	
Function Specifications	<b>Operation Mode</b>		Light on or dark on (selectable by switch on amplifier)	√	√
	<b>Indicator</b>		Operation indicator: Red LED (out)	√	√
			Stable level indicator: Green LED (stable)	√	√
	<b>Noise Resistance</b>	<b>Normal Mode</b>	500V	√	–
			300V	–	√
		<b>Common Mode</b>	300V	√	–
			150V	–	√
		<b>Pulse Width</b>	50ns – 1μs, 100Hz (using a noise simulator)	√	√
	<b>Storage Temperature</b>		–30 to +70°C (avoid freezing)	√	√
	<b>Insulation Resistance</b>		20M minimum with 500V DC megger (between live & dead parts)	√	√
	<b>Dielectric Strength</b>		1000V, 1 minute (between live & dead parts)	√	√
	<b>Vibration Resistance</b>		Damage limits: 10 – 55Hz Amplitude: 1.5mm p-p, 20 cycles in each of 3 axes crossed (one cycle = 5 minutes)	√	√
<b>Shock Resistance</b>		Damage limits: 500m/s <sup>2</sup> (approximately 49G), 10 shocks in each of 3 axes	√	√	
<b>Weight</b>		Cable type: Approximately 75g Quick-connect type: Approximately 30g	√	√	

PLCs

Operator Interfaces

### Detecting Color Marks

Color of Mark	Background Color										
	White	Yellow	Chartreuse	Orange	Red	Magenta	Turquoise	Blue	Violet	Green	Black
White	–	❖	◆	❖	❖	◆	◆	◆	◆	◆	◆
Yellow	❖	–	◆	❖	❖	❖	◆	◆	◆	◆	◆
Chartreuse	◆	◆	–	□	□	❖	□	◆	❖	◆	◆
Orange	❖	❖	□	–	–	❖	□	◆	◆	◆	◆
Red	❖	❖	□	–	–	□	□	◆	◆	◆	◆
Magenta	◆	❖	❖	❖	□	–	□	□	–	□	◆
Turquoise	◆	◆	□	□	□	□	–	□	◆	❖	◆
Blue	◆	◆	◆	◆	◆	□	□	–	□	□	□
Violet	◆	◆	❖	◆	◆	–	◆	□	–	□	□
Green	◆	◆	◆	◆	◆	□	❖	□	□	–	□
Black	◆	◆	◆	◆	◆	◆	◆	□	□	□	–

- = Use Red LED  
❖ = Use Green LED  
◆ = Use Red or Green LED  
– = Not Detectable

Automation Software

Power Supplies

Sensors

Communication &amp; Networking

**Part Numbers**

Function	Amplifier	Output	Light Source	Response	Through-Beam Units		Diffuse-Reflected Units	
					Part Number	Range	Part Number	Range
PLCs	SA1C-FN3E (Cable) SA1C-FN3EC (Quick-Connect)	30V DC NPN transistor: 100mA (maximum) Self-diagnostic: 50mA (maximum)	Red LED	Standard speed: 0.5 ms	SA9F-TS: ø0.16" (M4) Straight	180mm (7.09")	SA9F-DS: ø0.24" (M6) Straight	60mm (2.36")
		SA9F-TC: ø0.16" (M4) Coiled			150mm (5.91")	SA9F-DC: ø0.24" (M6) Coiled	25mm (0.98")	
Operator Interfaces	SA1C-FD3F (Cable) SA1C-FD3FC (Quick-Connect)	30V DC NPN transistor: 100mA (maximum) PNP transistor: 200mA (maximum)	Red LED	Standard speed: 0.5 ms	SA9F-TT: ø0.12" (M3) Straight	50mm (1.97")	SA9F-DD: ø0.24" (M6) Coaxial	60mm (2.36")
		SA9F-TM: ø0.16" (M4) Multicore			150mm (5.91")	SA9F-DT: ø0.12" (M3) Straight	20mm (0.79")	
Automation Software	SA1C-FN3EG (Cable) SA1C-FN3EGC (Quick-Connect)	30V DC NPN transistor: 100mA (maximum) Self-diagnostic: 50mA (maximum)	Green LED	Standard speed: 0.5 ms	SA9F-TS: ø0.16" (M4) Straight	16mm (0.63")	SA9F-DS: ø0.24" (M6) Straight	7mm (0.28")
		SA9F-TC: ø0.16" (M4) Coiled			14mm (0.55")	SA9F-DC: ø0.24" (M6) Coiled	N/A	
Automation Software	SA1C-FD3FG (Cable) SA1C-FD3FGC (Quick-Connect)	30V DC NPN transistor: 100mA (maximum) PNP transistor: 200mA (maximum)	Green LED	Standard speed: 0.5 ms	SA9F-TT: ø0.12" (M3) Straight	5mm (0.20")	SA9F-DD: ø0.24" (M6) Coaxial	7mm (0.28")
		SA9F-TM: ø0.16" (M4) Multicore			14mm (0.55")	SA9F-DT: ø0.12" (M3) Straight	N/A	
Power Supplies	SA1C-F1N3E (Cable) SA1C-F1N3EC (Quick-Connect)	30V DC NPN transistor: 100mA (maximum) Self-diagnostic: 50mA (maximum)	Red LED	High- speed: 50 µs	SA9F-TS: ø0.16" (M4) Straight	50mm (1.97")	SA9F-DS: ø0.24" (M6) Straight	20mm (0.79")
		SA9F-TC: ø0.16" (M4) Coiled			40mm (1.57")	SA9F-DC: ø0.24" (M6) Coiled	7mm (0.28")	
Power Supplies	SA1C-F1D3F (Cable) SA1C-F1D3FC (Quick-Connect)	30V DC NPN transistor: 100mA (maximum) PNP transistor: 200mA (maximum)	Red LED	High- speed: 50 µs	SA9F-TT: ø0.12" (M3) Straight	15mm (0.59")	SA9F-DD: ø0.24" (M6) Coaxial	20mm (0.79")
		SA9F-TM: ø0.16" (M4) Multicore			40mm (1.57")	SA9F-DT: ø0.12" (M3) Straight	6mm (0.24")	
Power Supplies	SA1C-F1D3F (Cable) SA1C-F1D3FC (Quick-Connect)	30V DC NPN transistor: 100mA (maximum) PNP transistor: 200mA (maximum)	Red LED	High- speed: 50 µs	SA9F-TH: Heat-resistant glass fiber	30mm (1.18")	SA9F-DM: ø0.01" (0.26mm) Multicore	18mm (0.71")
		SA9F-TL: Side view			13mm (0.51")	SA9F-DH: Heat-resistant glass fiber	7mm (0.28")	
							SA9F-DL: Side view	3mm (0.12")



Function is determined by the fiber optic unit used.

For information on accessories, see page 171.

## Universal Sensors Accessories

### Reflectors

Appearance	Item	Use with	Part Number
	200 x 300mm self-adhesive reflective tape	S51, S60, S62	S94000600 (model RT3870)
	200 x 300mm self-adhesive reflective tape		S94000900 (model RT3970)
	60 x 40mm self-adhesive reflective tape		S94000604 (model RT3970)
	Ø 23mm prismatic reflector with Ø 31mm support		S940700023 (model R1)
	Ø 48mm prismatic reflector with Ø 63mm support		S940700048 (model R2)
	18 x 54mm prismatic reflector with 22 x 82mm support		S940700972 (model R3)
	47x 47mm prismatic reflector with 51.5 x 61mm support		95A151010 (model R4)
	Ø 75mm prismatic reflector with Ø 82mm support		S940700075 (model R5)
	36 x 55mm prismatic reflector with 40.5 x 60mm support		95A151020 (model R6)
	38 x 40mm microprism reflector with 51 x 60.7mm support		95A151050 (model R7)
	9.7 x 19mm microprism reflector with 13.8 x 23mm support		95A151060 (model R8)
	Ø 23mm prismatic reflector with Ø 25mm self-adhesive support		95A151080 (model R9)
	36 x 176mm prismatic reflector with 41 x 181mm support		S19120000 (model R10)
	146 x 15mm prismatic reflector with 150 x 18mm support		95A155050 (model R11)

### Reflectors

Appearance	Item	Use with	Part Number
	Ø 48mm prismatic reflector with Ø 63mm support	S51, S60, S62	95A151090 (model R20)
	Ø 48mm prismatic reflector with CH.52mm hexagon support		S940710048 (model S12)
	Standard reflector	SA1E	IAC-R5
	Small reflector		IAC-R6
	Large reflector		IAC-R8
	Narrow (rear/side mounting)		IAC-R7M
	Narrow (rear mounting)		IAC-R7B
	Tape (35 x 40mm)		IAC-RS1
	Tape (70 x 80mm)	IAC-RS2	

### Brackets

Appearance	Item	Use with	Part Number
	M18/14 mounting bracket	S51	95ACC5230 (model ST-5010)
	M18 mounting bracket		95ACC5240 (model ST-5011)
	M18 mounting bracket		95ACC5250 (model ST-5012)
	M18 mounting bracket		95ACC5270 (model ST-5017)
	M18/14 adjustable mounting support (sensor not included)		95ACC5300 (model S50-EASY-IN)
	M18 jointed support		95ACC5220 (model JOINT-18)
	support with micrometric regulation for M18 tubular		95ACC1380 (model MICRO-18)

PLCs

Operator Interfaces

Automation Software

Power Supplies

Sensors

Communication &amp; Networking

**Brackets**

Appearance	Item	Use with	Part Number
	Front protection		G5000001 (model MEK-PROOF)
	1 pc adjustable support for M18 tubular	S51	895000006 (model SWING-18)
	2 pcs fixed support for M18 tubular		95ACC1370 (model SP-40)
	Protection bracket with jointed support		95ACC5350 (model JOINT-60)
	S60 mounting bracket	S60	95ACC1320 (model ST-504)
	Protection bracket		95ACC5310 (model ST-5018)
	Protection bracket		95ACC5320 (model ST-5019)
	Mounting bracket	S60, S62, S65	95ACC5330 (model ST-5020)
	Mounting bracket		95ACC5340 (model ST-5021)
	Protection bracket	S62	95ACC2410 (model ST-5053)
	Protection bracket		95ACC2420 (model ST-5054)
	Vertical mounting bracket		SA9Z-K01
	Horizontal mounting bracket		SA9Z-K02
	Cover mounting bracket		SA9Z-K03
	Reflector mounting bracket	SA1E	IAC-L2
	Reflector mounting bracket		IAC-L3
photo not available	Reflector mounting bracket		IAC-L5

**Slits**

Appearance	Item	Slit Size	Use with	Part Number	Min. Order Qty
		0.5mm x 18mm	SA1E	SA9Z-S06	2
		1.0mm x 18mm		SA9Z-S07	
		2.0mm x 18mm		SA9Z-S08	
		0.5mm x 6.5mm	SA1E	SA9Z-S09	
		1.0mm x 6.5mm		SA9Z-S10	
		2.0mm x 6.5mm		SA9Z-S11	
		ø0.5mm	SA1E	SA9Z-S12	
		ø1.0mm		SA9Z-S13	
		ø2.0mm		SA9Z-S14	

**Air Blower Mounting Blocks**

Appearance	Item	Use with	Part Number
	Air blower mounting block	SA1E	SA9Z-A02

**Connector Cables (for connector model sensors)**

Appearance	Number of Core Wires	Type & Length	Use with	Part No.
	4	Straight, 5m	S51, S60, S62	CS-A1-02-G-05
	4	Right angle, 5m		CS-A2-02-G-05
	4	Straight, 2m	SA1E	SA9Z-CM8K-4S2
		Straight, 5m		SA9Z-CM8K-4S5
		Right angle, 2m		SA9Z-CM8K-4L2
		Right angle, 5m		SA9Z-CM8K-4L5
photo not available	4	2m	SA1C-F	SA9C-CA4D2
		5m		SA9C-CA4D5
		2m		SA9C-CA4D2S
		5m		SA9C-CA4D5S

PLCs

Operator Interfaces

Automation Software

Power Supplies

Sensors

Communication & Networking

## Diffuse-Reflected Light Fiber Optic Units - SA9F

Appearance	Part Number	Description	Use with	Range
	<b>SA9F-DS31</b> No sleeve <b>SA9F-DS32</b> 3.54" (90mm) sleeve <b>SA9F-DS33</b> 1.77" (45mm) sleeve	Straight: Two fibers $\varnothing 1\text{mm}$ (0.04") Threaded mount: $\varnothing 6\text{mm}$ (M6) Detects: $\varnothing 0.03\text{mm}$ (0.0012") minimum object	SA1C-FK3 SA1C-FK3G SA1C-F	60mm (2.36") 7mm (0.28")
	<b>SA9F-DC31</b> No sleeve <b>SA9F-DC32</b> 3.54" (90mm) sleeve <b>SA9F-DC33</b> 1.77" (45mm) sleeve (All three not compatible with green LED)	Coiled: Two fibers $\varnothing 1\text{mm}$ (0.04") Threaded mount: $\varnothing 6\text{mm}$ (M6) Detects: $\varnothing 0.03\text{mm}$ (0.0012") minimum object	SA1C-FK3 SA1C-FK3G SA1C-F	25mm (0.98") —
	<b>SA9F-DT11</b> No sleeve <b>SA9F-DT12</b> 3.54" (90mm) sleeve <b>SA9F-DT13</b> 1.77" (45mm) sleeve (All three not compatible with green LED)	Straight: Two fibers $\varnothing 0.5\text{mm}$ (0.02") Threaded mount: $\varnothing 3\text{mm}$ (M3) Detects: $\varnothing 0.03\text{mm}$ (0.0012") minimum object	SA1C-FK3 SA1C-FK3G SA1C-F	20mm (0.78") —
	<b>SA9F-DD31</b>	Coaxial: Core $\varnothing 1\text{mm}$ (0.04") + 16 fibers: $\varnothing 0.26\text{mm}$ (0.01") Threaded mount: $\varnothing 6\text{mm}$ (M6) Detects: $\varnothing 0.03\text{mm}$ (0.0012") minimum object	SA1C-FK3 SA1C-FK3G SA1C-F	60mm (2.36") 7mm (0.28")
	<b>SA9F-DM74</b> 1 row = 32 fibers <b>SA9F-DM75</b> 2 rows = 16 each (Not compatible with green LED)	Multicore: 32 fibers $\varnothing 0.26\text{mm}$ (0.010") Detects: $\varnothing 0.06\text{mm}$ (0.0024") minimum object	SA1C-FK SA1C-FK3G SA1C-F (not compatible with SA9F-DM75, SA9F-DM76)	60mm (2.36") 4mm (0.16")
	<b>SA9F-DH21</b> No sleeve <b>SA9F-DH22</b> 3.54" (90mm) sleeve (Both not compatible with green LED)	Heat-resistant glass: Two fibers $\varnothing 0.7\text{mm}$ (0.03") Threaded mount: $\varnothing 4\text{mm}$ (M4) Detects: $\varnothing 0.03\text{mm}$ (0.0012") minimum object	SA1C-FK3 SA1C-FK3G SA1C-F	27mm (1.06") —

PLCs

Operator Interfaces

Automation Software







Power Supplies

Sensors

Communication &amp; Networking



Through-Beam Fiber Optic Units - SA9F

Appearance	Part Number	Description	Amplifier	Range
	<b>SA9F-TS21</b> No sleeve	Straight fiber: ø1mm (0.04") Threaded mount: ø4mm (M4)	SA1C-FK3 SA1C-FK3G SA1C-F	180mm (7.09") 16mm (0.63")
	<b>SA9F-TS23</b> 1.77" (45mm) sleeve	Detects: ø0.3mm (0.012") minimum object		
	<b>SA9F-TC21</b> No sleeve	Coiled fiber: ø1mm (0.04") Threaded mount: ø4mm (M4)	SA1C-FK3 SA1C-FK3G SA1C-F	150mm (5.91") 14mm (0.55")
		Detects: ø0.3mm (0.012") minimum object		
	<b>SA9F-TT11</b> No sleeve	Straight fiber: ø0.5mm (0.02") Threaded mount: ø3mm (M3)	SA1C-FK3 SA1C-FK3G SA1C-F	50mm (1.97") 5mm (0.2")
		Detects: ø0.15mm (0.006") minimum object		
	<b>SA9F-TM21</b> No sleeve <b>SA9F-TM22</b> 3.54" (90mm) sleeve <b>SA9F-TM23</b> 1.77" (45mm) sleeve 16 fibers (cluster)	Multicore: ø0.26mm (0.010") Threaded mount: ø4mm (M4)	SA1C-FK3 SA1C-FK3G SA1C-F	150mm (5.91") 14mm (0.55")
		Detects: ø0.3mm (0.012") minimum object		
	<b>SA9F-TM74</b> 16 fibers in one row	Multicore: 16 fibers (one row) ø0.26mm (0.010")	SA1C-FK3 SA1C-FK3G SA1C-F	150mm (5.91") 14mm (0.55")
		Detects: ø0.06mm (0.0024") minimum object		
	<b>SA9F-TH21</b> No sleeve <b>SA9F-TH22</b> 3.54" (90mm) sleeve	Heat-resistant glass fiber: ø1mm (0.04") Threaded mount: ø4mm (M4)	SA1C-FK3 SA1C-FK3G SA1C-F	100mm (3.94") 8mm (0.31")
		Detects: ø0.3mm (0.012") minimum object		

PLCs

Operator Interfaces

Automation Software

Power Supplies

Sensors

Communication & Networking



## Miscellaneous Accessories

Description	Use with		Part Number
Fiber cutter	All fiber units except heat resistant	HxLxD: 23x 45 x 8mm (0.91" x 1.77" x 0.31") Included with fiber units; order replacement only	SA9Z-F01
Set of 2 easy-insert adaptors	SA9F-TT, SA9F-TL, SA9F-DT, and SA9F-DL	ø2.2 x 24mm long (ø0.087" (OD) x 0.945") Included with applicable fiber optic units; order replacement set only	SA9Z-F02
Lens attachment for long-range detection of opaque objects, minimum size: Ø 0.14" (3.5mm)	SA1C-F through-beam fiber unit only		SA9Z-F11
	Sensing ranges: Standard speed red LED: SA9F-TS21: 1.3m (4' – 3-3/16") SA9F-TC21: 1m (3' – 3-3/8") 0.1m (3.94") SA9F-TM21: 1.05m (3' – 5-3/8")		
	Sensing ranges: Standard speed green LED: SA9F-TS21: 0.135m (5.31") SA9F-TC21: 0.1m (3.94") SA9F-TM21: 0.13m (5.12")		
Side view attachment to rotate axis by 90° for detection of opaque objects, minimum size: Ø 0.14" (3.5mm)	SA1C-F through-beam fiber unit only		SA9Z-F12
	Sensing ranges: Standard speed red LED: SA9F-TS21: 200mm (7.87") SA9F-TC21: 130mm (5.12") SA9F-TM21: 160mm (6.30")		
	Sensing ranges: High-speed red LED: SA9F-TS21: 50mm (1.97") SA9F-TC21: 35mm (1.38") SA9F-TM21: 40mm (1.57")		
Side-on attachment for narrow clearance, Range: 1.26" (32mm), for detection of transparent or opaque objects	SA1C-F diffuse-reflected light fiber unit only	Sensing ranges: Standard speed red LED: SA9F-TS21: 35mm (1.38") SA9F-TC21: 30mm (1.81") SA9F-TM21: 35mm (1.38")	SA9Z-F13
Attachment for high-accuracy: Range: 0.4" ± 0.04" (10mm ± 1mm), for detection of transparent or opaque objects	SA1C-F through-beam fiber unit only		SA9Z-F14
	Sensing ranges: Standard speed red LED: SA9F-TS21: 10mm ± 1mm SA9F-TC21: (0.394" ± 0.039") SA9F-TM21:		

PLCs

Operator Interfaces

Automation Software

Power Supplies

Sensors

Communication &amp; Networking



Dimensions (mm)

95A151050 (model R7)

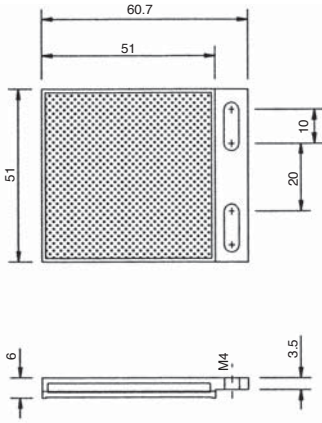

95A151060 (model R8)



95A151080 (model R9)



S19120000 (model R10)



95A155050 (model R11)

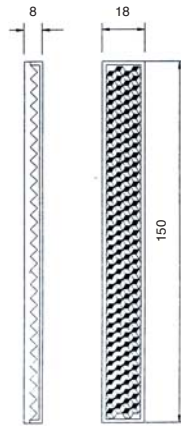

S940710048 (model S12)

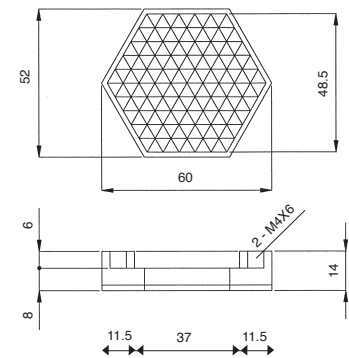

IAC-R5



IAC-R6

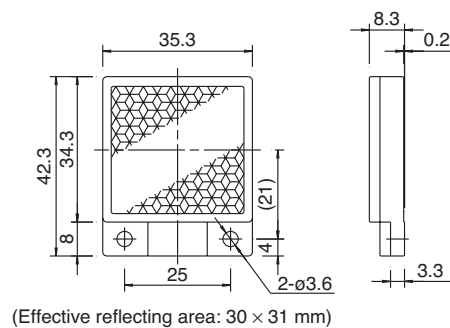

IAC-RS1

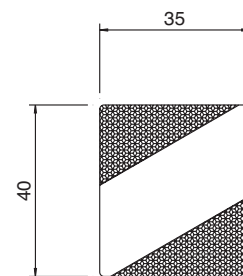

PLCs

Operator Interfaces

Automation Software

Power Supplies

Sensors

Communication & Networking

**Brackets**

Dimensions (mm)

**95ACC5230** (model ST-5010)

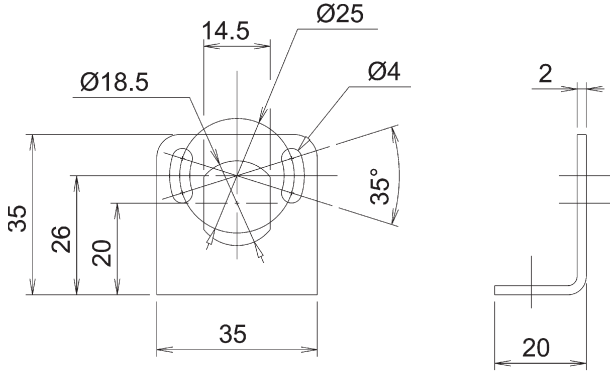

**95ACC5240** (model ST-5011)

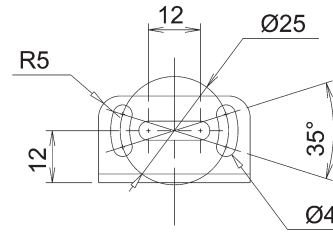
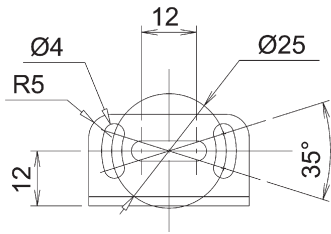
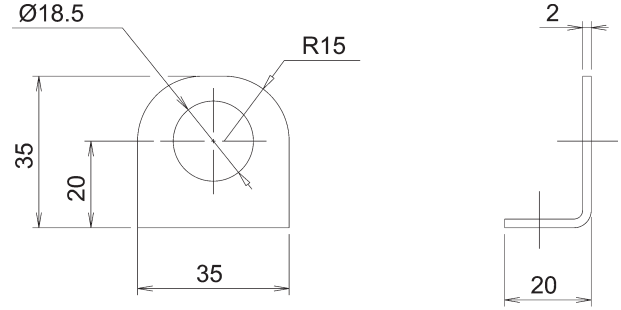

**95ACC5250** (model ST-5012)

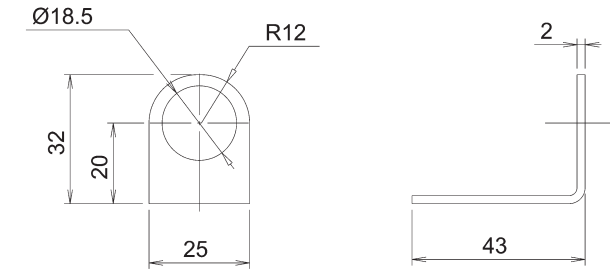

**95ACC5270** (model ST-5017)

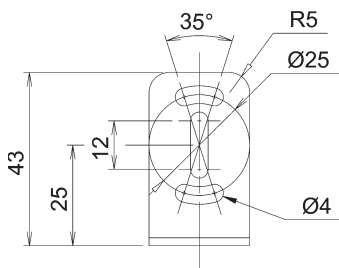
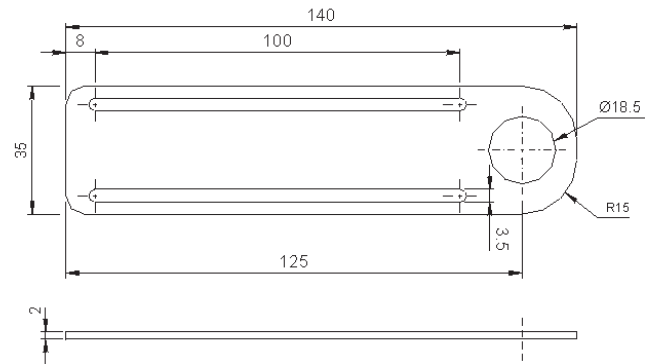

PLCs

Operator Interfaces

Automation Software

Power Supplies

Sensors

Communication & Networking

Dimensions (mm)

**95ACC5300 (model S50-EASY-IN)**



**95ACC5220 (model JOINT-18)**



PLCs

Operator Interfaces

Automation Software

Power Supplies

Sensors

Communication & Networking

Dimensions (mm)

**95ACC1380** (model MICRO-18)

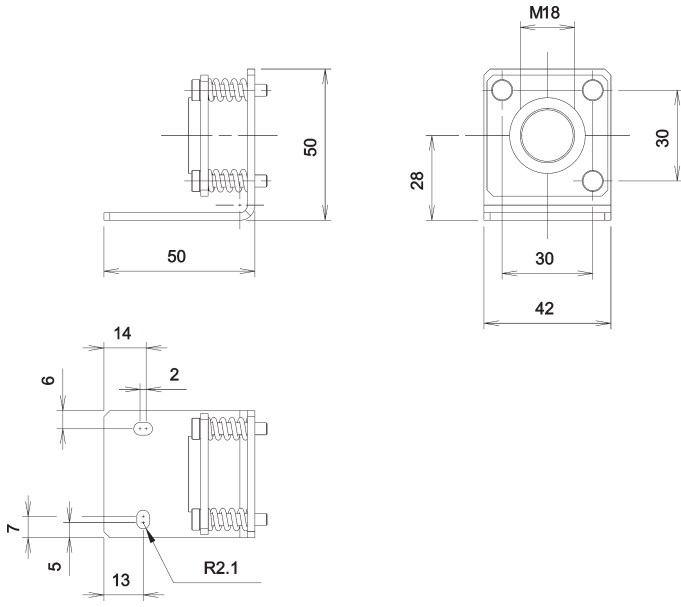

**895000006** (model SWING-18)

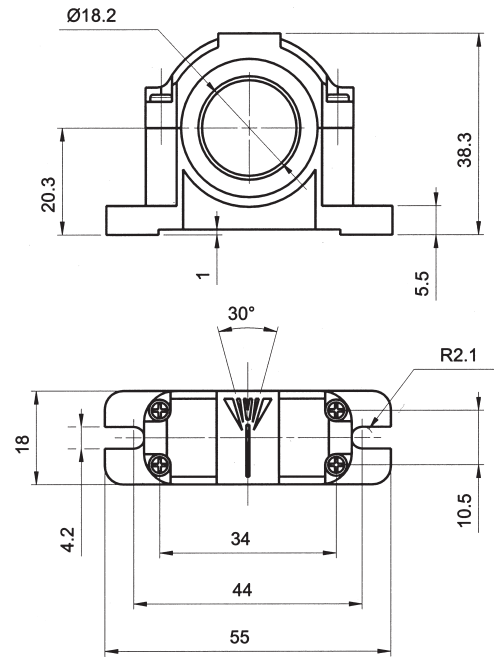

**95ACC1370** (model SP-40)

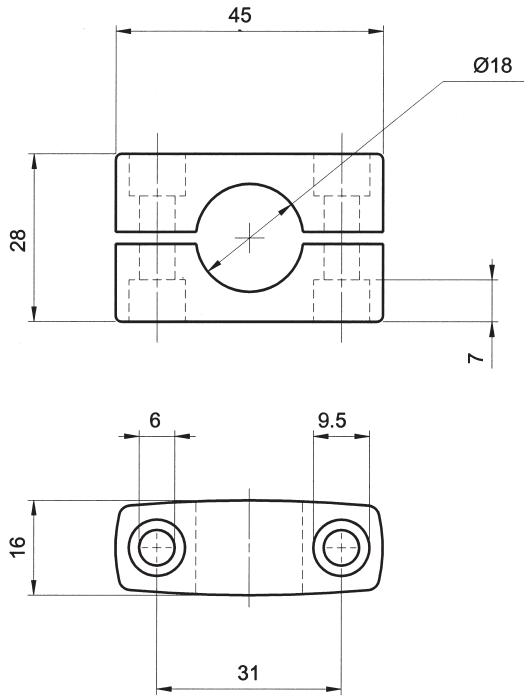

**G5000001** (model MEK-PROOF)

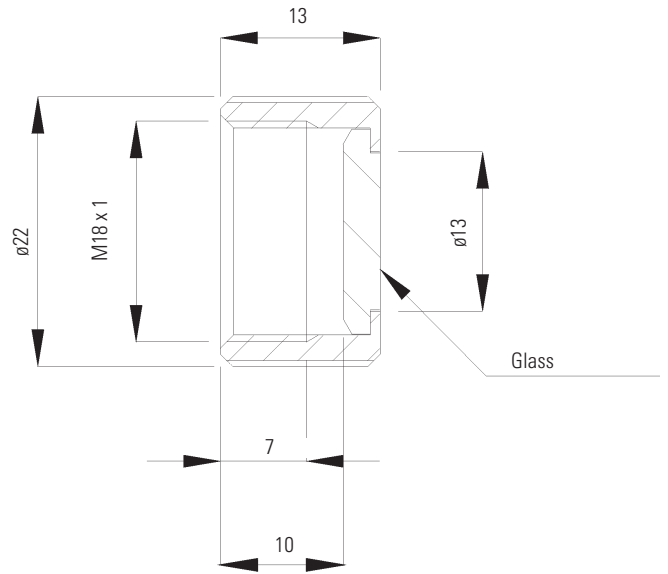

PLCs

Operator Interfaces

Automation Software

Power Supplies

Sensors

Communication & Networking

Dimensions (mm)

**95ACC5350 (model JOINT-60)**



**95ACC1320 (model ST-504)**

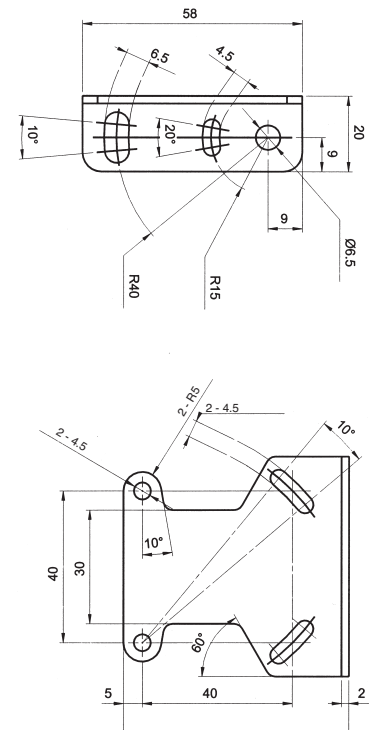

**95ACC5310 (model ST-5018)**



**95ACC5320 (model ST-5019)**

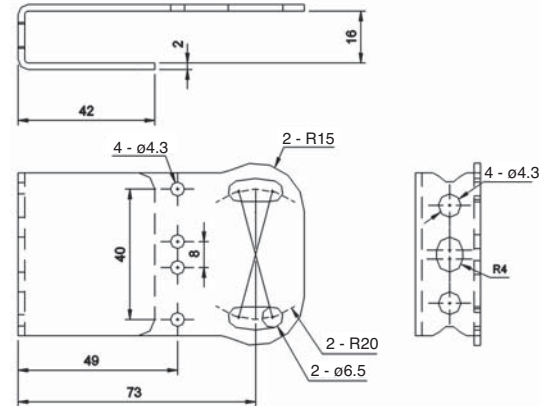

PLCs

Operator Interfaces

Automation Software

Power Supplies

Sensors

Communication & Networking



PLCs

Operator Interfaces

Automation Software

Power Supplies

Sensors

Communication & Networking

95ACC5330 (model ST-5020)

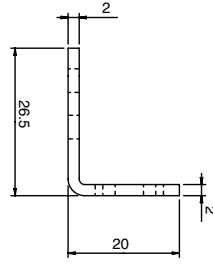
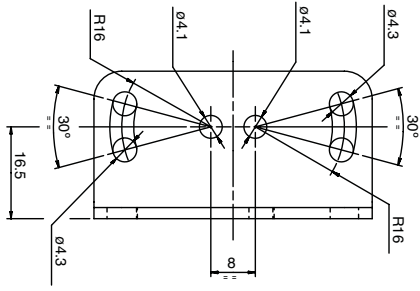

95ACC5340 (model ST-5021)

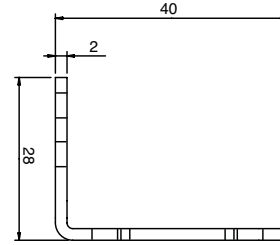
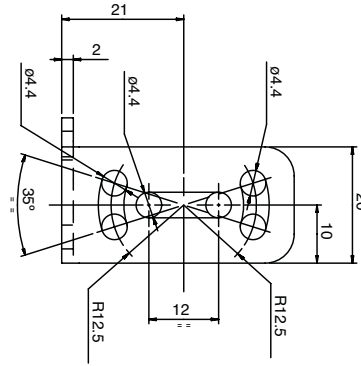

Dimensions (mm)

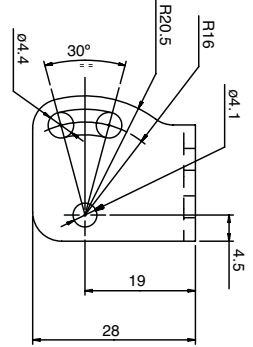

95ACC2410 (model ST-5053)

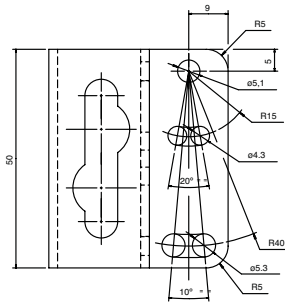
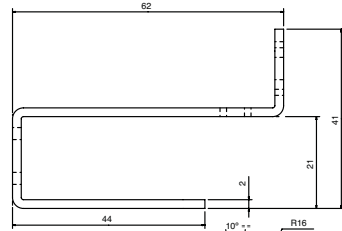

95ACC2420 (model ST-5054)

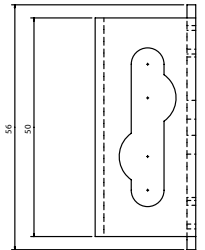
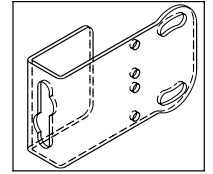
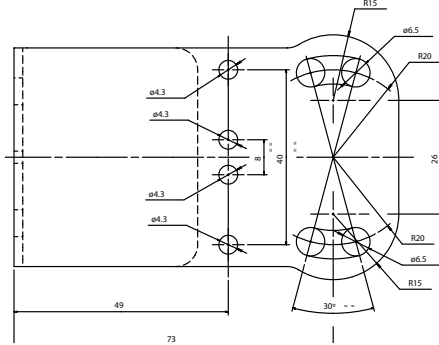
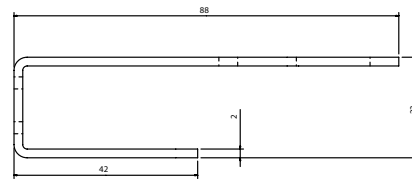

Dimensions (mm)

SA9Z-K01

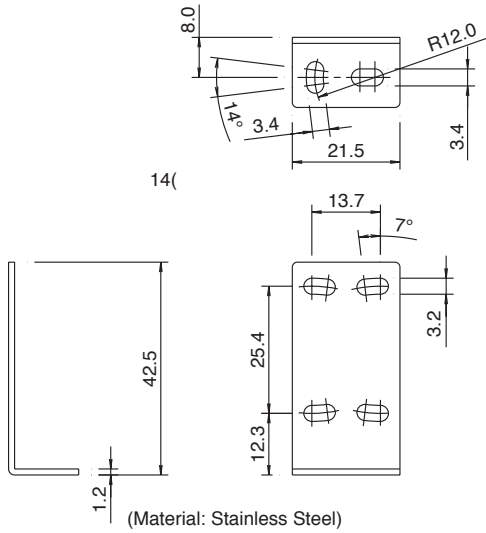

SA1E with SA9Z-K01 Mounting Bracket



Note 1: Center of optical axis (through-beam type)  
 Note 2: Center of optical axis (polarized retro-reflective, diffuse reflective, and small-beam reflective type)

SA9Z-K02

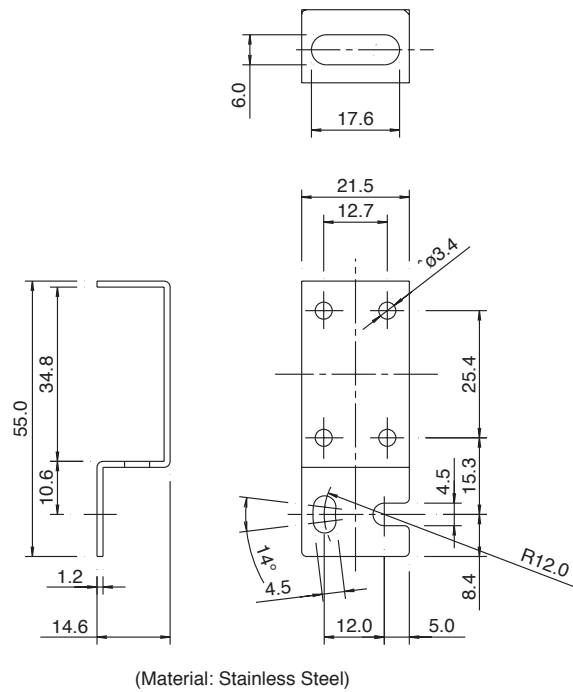

SA1E with SA9Z-K02 Mounting Bracket

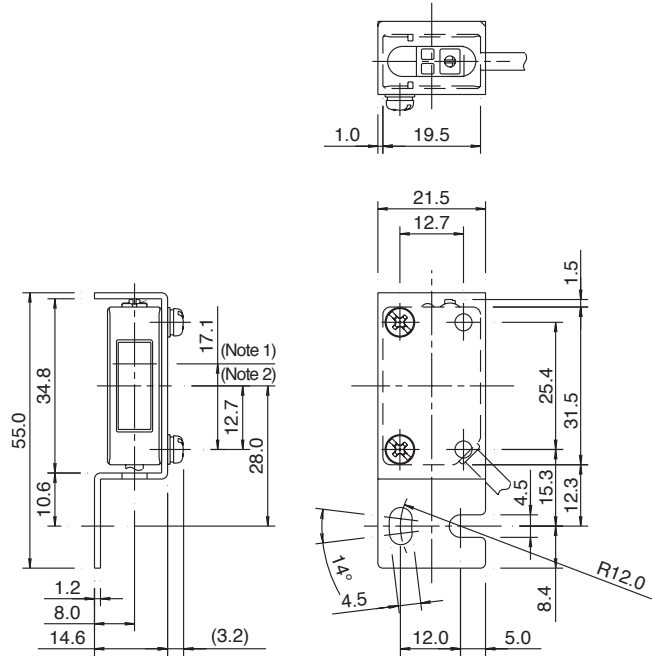

Note 1: Center of optical axis (through-beam type)  
 Note 2: Center of optical axis (polarized retro-reflective, diffuse reflective, and small-beam reflective type)

PLCs

Operator Interfaces

Automation Software

Power Supplies

Sensors

Communication & Networking

**Reflector Mounting Brackets**

**IAC-L2**



Material: SPCC (zinc chromate plating, black)

**IAC-L3**

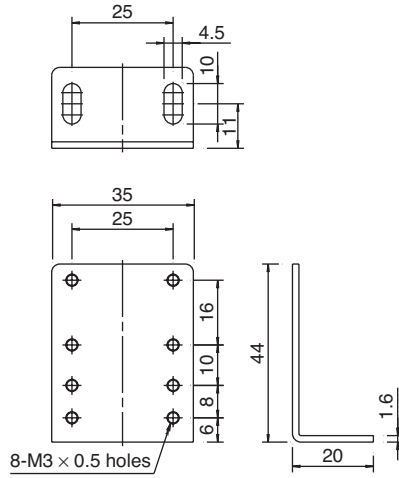

Material: SPCC (zinc plating)

Dimensions (mm)

**Connector Cable (one side connector)**

**Straight Type**

SA9Z-CM8K-4S □

- ① Black
- ② Blue
- ③ White
- ④ Brown

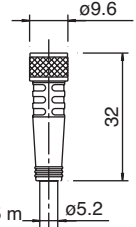

Cable length: 2 or 5 m

Note: Dielectric strength when installed on the switch  
Between live part and mounting bracket: 1000V AC (except between live part and clamping ring)

**Right-angle Type**

SA9Z-CM8K-4L □

- ① Black
- ② Blue
- ③ White
- ④ Brown



Cable length: 2 or 5 m

Note: Dielectric strength when installed on the switch  
Between live part and mounting bracket: 1000V AC (except between live part and clamping ring)

**Cables for SA1C-F**

**SA9C-CA4D2, SA9C-CA4D5**

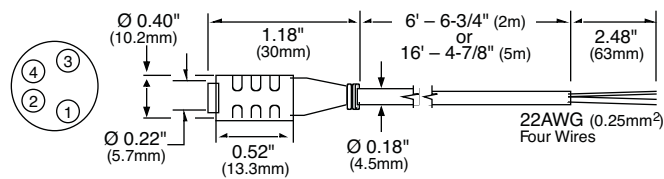

**SA9C-CA4D2S, SA9C-CA4D5S**

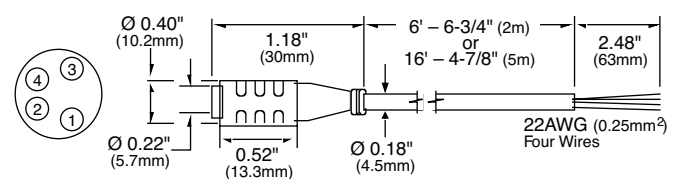

PLCs

Operator Interfaces

Automation Software

Power Supplies

Sensors

Communication & Networking

Miscellaneous Accessories

SA9Z-F01

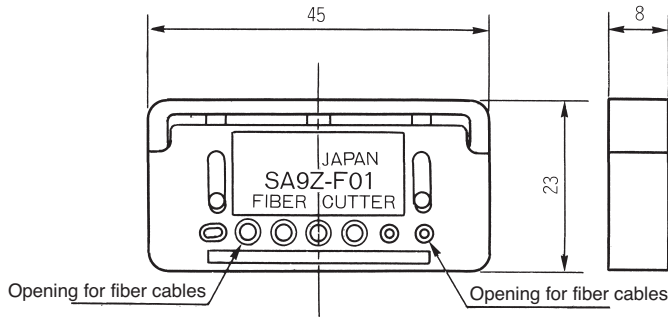

SA9Z-F02

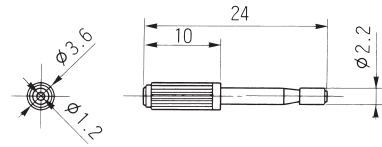

Dimensions (mm)

Attachments for Fiber Optic Sensor SA1C-F

SA9Z-F11

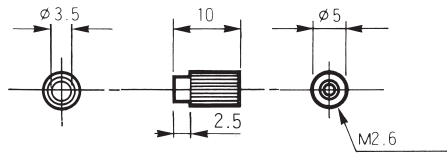

SA9Z-F12

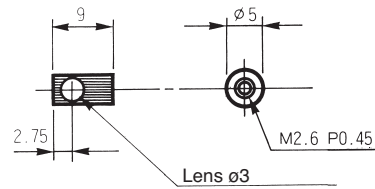

Fiber Optic Model	Distance (mm)		
	SA1C-F*	SA1C-F*G	SA1C-F1*
SA9F-TS21	1300	135	400
SA9F-TC21	1000	100	300
SA9F-TM21	1050	130	380

Fiber Optic Model	Distance (mm)	
	SA1C-F*	SA1C-F1*
SA9F-TS21	200	50
SA9F-TC21	130	35
SA9F-TM21	160	40

SA9Z-F13

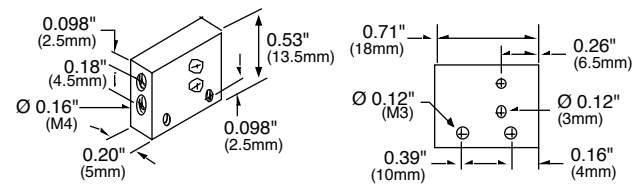

SA9Z-F14

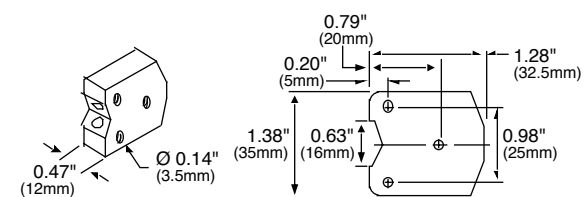

Diffuse-Reflective Light Fiber Optic Units

SA9F-DS31

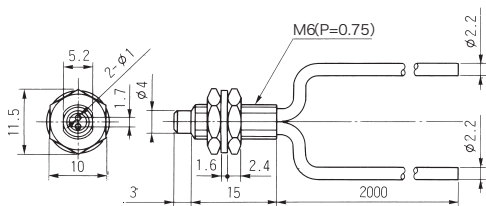

SA9F-DS32, SA9F-DS33

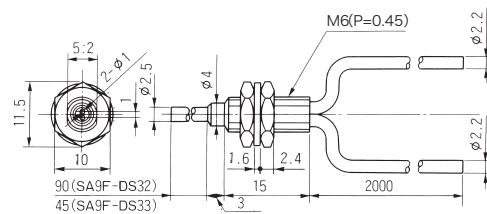

PLCs

Operator Interfaces

Automation Software

Power Supplies

Sensors

Communication & Networking

Dimensions (mm)

**Diffuse-Reflective Light Fiber Optic Units con't**

**SA9F-DC31**



**SA9F-DC32, SA9F-DC33**



**SA9F-DT11**

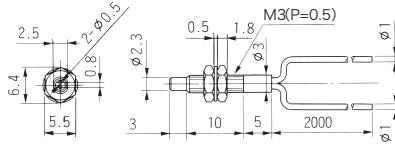

**SA9F-DT12, SA9F-DT13**

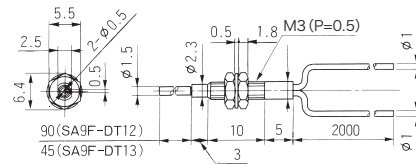

**SA9F-DD31**



**SA9F-DM74**



**SA9F-DM75**



**SA9F-DH21**



**SA9F-DH22**



PLCs

Operator Interfaces

Automation Software

Power Supplies

Sensors

Communication & Networking

## Diffuse-Reflective Light Fiber Optic Units con't

Dimensions (mm)

## SA9F-TS21

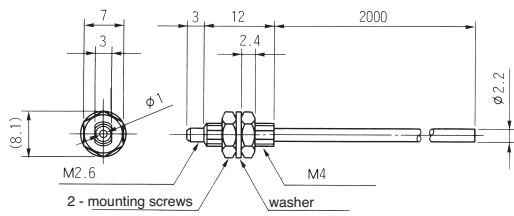

## SA9F-TS23

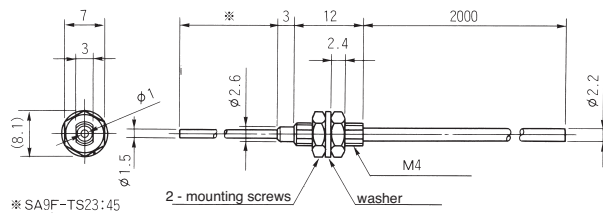

## SA9F-TC21

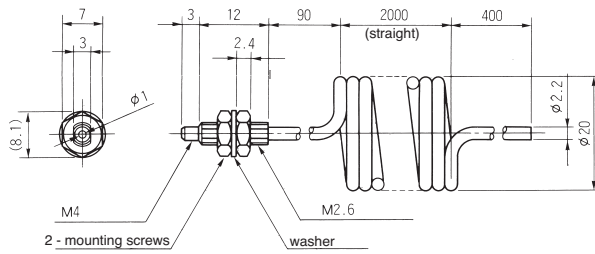

## SA9F-TT11

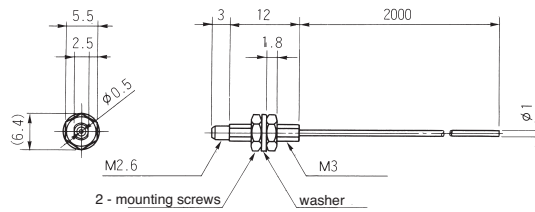

## SA9F-TM21

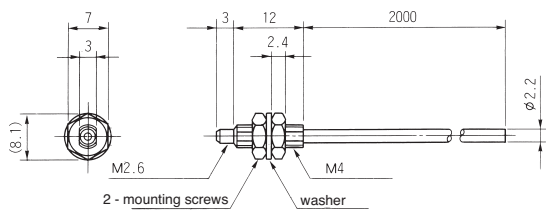

## SA9F-TM22, SA9F-TM23

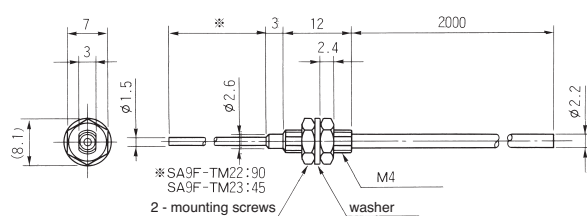

## SA9F-TM74

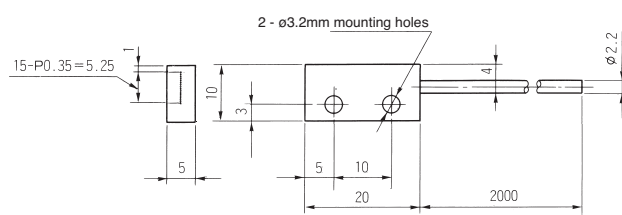

## SA9F-TH21

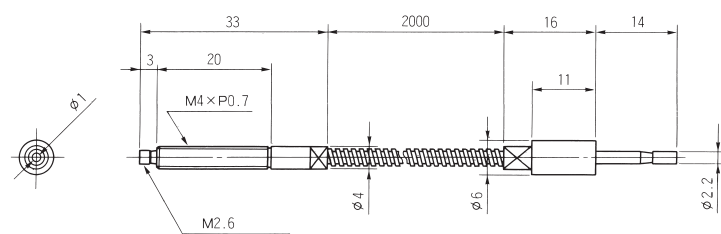

PLCs

Operator Interfaces

Automation Software

Power Supplies

Sensors

Communication &amp; Networking

## General Information

### Specifications

Do not operate a sensor under any conditions exceeding these specifications.

Do not operate a sensor under current and voltage conditions other than those for which the individual sensor is rated.

Do not exceed the recommended operating temperature and humidity. Although sensors are rated for operation below 0°C, this specification does not imply that performance characteristics will remain constant under prolonged freezing conditions. Continued exposure and the accompanying frost, ice, dew, and condensation which accumulate on the optical surface will adversely affect sensor performance.

To maintain performance characteristics, do not exceed vibration and shock resistance ratings while operating a sensor. In addition, avoid impacts to the sensor housing which are severe enough to adversely affect the waterproof characteristics.

### IEC (International Electrotechnical Commission) Ratings

Sensors rated IP67 are resistant to moisture when occasionally immersed in water. Sensors rated IP64 through IP66 are resistant to moisture when occasionally subjected to splashing or when located in the vicinity of turbulent waters. These ratings do not imply that a sensor is intended for use under continual high-pressure water spray. Avoid such applications to maintain optimal sensor performance.

Sensors rated IP64 through IP67 are dust-tight and water-tight. For best performance, avoid using any sensor in an area where it will be subjected to heavy particle blasts and where dust, water, or steam will accumulate on the optical surface.

### Start-up

Do not test the housing for dielectric strength and insulation resistance, since the housing is connected to the electronic circuit ground of a sensor. Do not perform dielectric strength and insulation resistance tests on electrical systems without disconnecting photoelectric sensors, as such testing may result in damage to the sensor.

Several lines of sensors, as noted in the individual operation sections, are provided with an internal circuit to turn an output off for a specified amount of time upon power-up. This delay is normal; it prevents a transient state when turning power on.

### Optimum Performance

The optical surface of each sensor must be cleaned on a regular basis for continual superior performance. Use a soft cloth dipped in isopropyl alcohol to remove dust and moisture build-up.

**IMPORTANT:** Do not use organic solvents (such as thinner, ammonia, caustic soda, or benzene) to clean any part of a sensor.

All sensors experience signal inconsistencies under the influence of inductive noise. Do not use sensors in close proximity to transformers, large inductive motors or generators. Avoid using sensors in direct contact with sources of excessive heat. Also avoid operation in close proximity to welding equipment.

### Light

Visible light is electromagnetic radiation with a wavelength between 390 and 770nm. White light is composed of all the visible spectrum components in equal quantity; the predominance of a specific wavelength determines the color of the light. Light Emitting Diodes (LEDs) are the most common light used in optoelectronics.



### Transmission, Absorption, Reflection

When light hits an object three things take place at the same time: reflection ( $\rho$ ), absorption ( $\alpha$ ) and transmission ( $\tau$ ); with parameters and ratios that vary according to the object themselves, which are then further differentiated by material, surface, thickness and/or color. These elements can be detected using a photoelectric sensor.

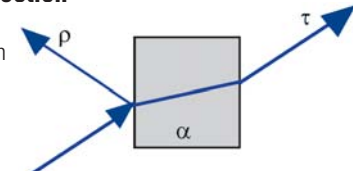

### Extraneous Light

Bright, extraneous light such as sunlight, incandescent lights, or fluorescent lights may impair the performance of sensors in detecting color or light.

Make sure that extraneous light does not exceed recommended levels found in the individual specifications sections. When 500 lux is specified, this is equal to 50 footcandles. The average factory illumination is ordinarily below this level, except in areas where visual inspection is being performed. Only in such brightly lit areas is incident light of particular concern.

Unwanted light interference can often be avoided simply by making sure that the optical receiver is not aimed directly toward a strong light source. When mounting direction cannot be adjusted, place a light barrier between all nearby light sources and the receiver.

### Through-beam Sensors



With through-beam sensors, the light emitter and receiver are contained in two different housings that are mounted one in front of the other. The light beam emitted by the emitter directly hits the receiver; each object that interrupts the beam is detected. This system is used to obtain large signal differences (when the light directly hits the receiver and when the object interrupts the beam) with the highest Excess Gain and the largest operating distance reaching up to 50m. These sensors can operate in the harshest environmental conditions, such as in the presence of dirt or dust. The disadvantage is that two units have to be wired (an emitter and receiver). The through-beam optic function operates typically in dark mode: the output is activated when the object interrupts the beam between the emitter and receiver.



It is strongly recommended to avoid using any sensor where it will be continually subjected to elements which impair performance or cause corrosive damage to the sensor. In particular, avoid strong vibrations and shocks, corrosive gases, oils and chemicals, as well as blasts of water, steam, dust or other particles.



A slit attachment is available to modify the beam size of through-beam sensors. This option is recommended for detecting very small objects (near the size of the smallest object which a sensor can detect) or for eliminating light interference when sensors are mounted in close proximity.

**Retro-reflective**

Photoelectric sensors with this function contain both the emitter and receiver inside the same housing. The emitted light beam is reflected on the receiver due to a prismatic reflector; an object is detected when it interrupts the beam. Compared to the through-beam optic function, the signal difference is reduced (when the light is freely reflected by the reflector and when an object interrupts the beam) so Excess Gain is reduced and maximum operating distances can reach 12 meters. It is necessary to operate in clean environments without dirt or dust. A retro-reflective sensor typically operates in the dark mode: output is activated when an object interrupts the light beam between the sensor and reflector.

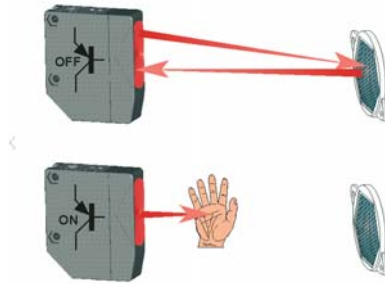

When installing sensors which detect reflected light, make sure that unwanted light reflections from nearby surfaces, such as the floor, walls, reflective machinery or stainless steel, do not reach the optical receiver.

Also, make sure that reflected-light sensors mounted in close proximity do not cause interfering reflections. When it is not possible to maintain the recommended clearance between sensors, as noted in the individual installation sections, provide light barriers between sensors.

**Prismatic Reflector**

A prismatic reflector is able to reflect incident light in a parallel manner, with a reflection coefficient higher than any other object for angles less than 15°. Typically the operating distance proportionally increases according to the reflector's dimensions. The reflector can rotate the incident light's polarization plane at 90°.

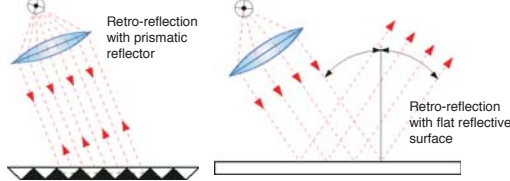

**Polarized Retro-reflective**

In presence of critical detection of objects with very reflective surfaces, such as shiny metals or mirrored glass, retroreflex sensors with polarized filters have to be used. In polarized retroreflex sensors, the emission light is polarized on a vertical plane, while the reception is obtained only through a polarized filter on a horizontal plane. A prismatic reflector rotates the light plane at a right angle, while the light reflected from the object maintains polarization plane unvaried and is blocked by the filter placed on the receiver. Consequently, only the light reflected by the prismatic reflector is received.



**Retro-reflective for Transparent Objects**

For detection of transparent objects, such as PET bottles or Mylar sheets, a low-hysteresis retro-reflective sensor (capable of detecting small signal differences) can be used. These sensors detect small signal differences that the light undergoes when it passes through a transparent object.



**Diffuse Proximity**

Photoelectric sensors with this function contain both the emitter and receiver inside the same housing. The emitted light beam is reflected on to the receiver directly by the object, which is detected without the need of prismatic reflectors. Proximity sensors represent the most economic and fastest mounting solution. However, they work with weaker signals compared to retro-reflective sensors. Excess Gain is reduced and operating distance, depending on the object's reflection degree, can only reach 2 meters.

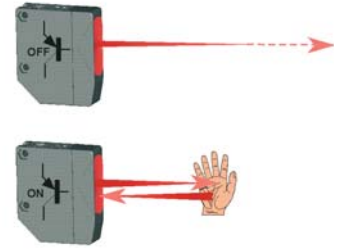

A proximity sensor normally operates in light mode: the output is activated when an object enters the detection area and reflects light emitted by the sensor.

**Background Suppression**

Background suppression sensors allow the operator to precisely set the maximum detection distance. The operating distance adjustment is not based upon the receiver's sensitivity, but is obtained through optic triangulation, mechanically acting on the lenses or photoelements angle or electronically using PSD (Position-Sensitive Detectors) receiving systems. Consequently the detection of an object is independent of other objects behind (or in the background), which are suppressed. Moreover, due to this adjustment method, all objects can be detected at the same distance independent of their color.

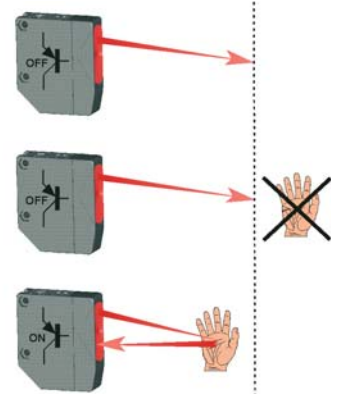

**Distance Sensors**

Distance sensors supply an analog signal of 0-10V or 4-20mA proportional to the measurement of the distance between the emitting optics and the target.



The main technologies involved are optic triangulation and time-of-flight. The first allows very precise measurements on short distances, while the second is ideal for medium and long distances.

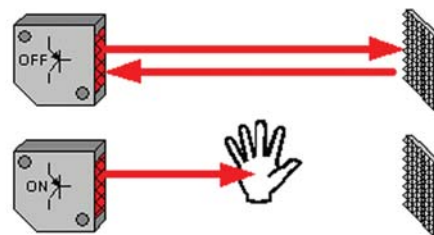

PLCs

Operator Interfaces

Automation Software

Power Supplies

Sensors

Communication & Networking

## Slot Sensors



A slot sensor is a version of a through-beam retro-reflective sensor, where the emitter and receiver are placed opposite each other on the inside of an U-shaped housing. Any target that passes through the internal slot interrupts the beam and is detected. Due to their construction, slot sensors are great for applications with short operating distances. The most typical slot sensor applications are hole or teeth detection on gears, label detection, or edge control and continuity of sheets or tapes. The emission is generally infrared light; however visible red or green emission versions are available and able to detect references such as registration marks, that present color contrasts on transparent film.

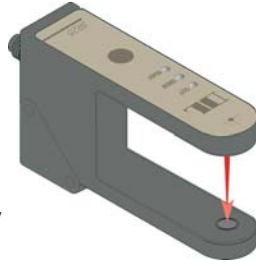

## Contrast Sensors



Contrast sensors (also defined as color mark readers) present a proximity function but, instead of detecting only the presence or absence of an object, they are able to distinguish between two surfaces. This is accomplished by detecting the contrast produced by the different reflection degrees. In this manner a dark reference mark (low reflection) can be detected due to the contrast with a lighter surface (high reflection), or vice versa. In the presence of colored surfaces, the contrast is highlighted using an LED, typically red or green. For general purposes a white light is used because the full light spectrum detects the majority of contrasts. White light emission is obtained through lamps, or LEDs in most sensors, enabling the detection of very slight contrasts due to different surface treatments, even of the same material and color.

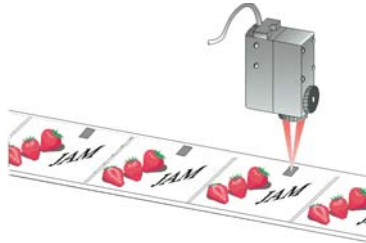

Contrast sensors are mainly used in automatic packaging machines for registration mark detection to synchronize folding, cutting and welding.

Contrast on White Background			
Mark Color	Red LED	Green LED	White LED
Red	no	medium	medium
Orange	low	medium	medium
Yellow	low	low	medium
Green	high	no	medium
Blue	high	medium	high
Violet	medium	high	high
Brown	low	medium	high
Black	high	high	high
Gray	medium	medium	medium
White	no	no	yes

## Luminescence Sensors



'Luminescence' is defined as visible light emission from fluorescent or phosphorous substances, due to electromagnetic radiation absorption. Luminescence sensors emit ultraviolet light, which is reflected at a higher wavelength (minor energy) on a fluorescent surface, shifting into the visible light spectrum. Ultraviolet light emission is obtained using special lamps, or LEDs in sensors. UV emission is modulated and the visible light reception is synchronized. Maximum immunity against external interferences, such as reflections caused by very shiny surfaces, is obtained. In addition, fluorescent targets, invisible to the human eye, can be detected. Luminescence sensors are used in various industries: detecting labels on glass or mirrors in pharmaceutical and cosmetic fields; selecting tiles marked with fluorescent marks in the ceramic industry; determining the presence of fluorescent glues on paper for automatic packaging; distinguishing cutting and sewing guides in textile manufacturing; checking fluorescent paints or lubricants in mechanical production.

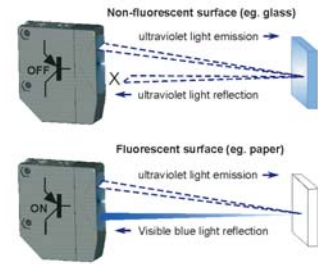

## Color Sensors



The color of an object depends on all the color components of the incident light which are being reflected, eliminating those which have been absorbed. The dominant color is defined as 'hue' and depends on the reflected light's wavelength. 'Saturation' indicates the pureness of the color with respect to white and is represented as a percentage. Hue and saturation together are defined as 'chromaticity'.

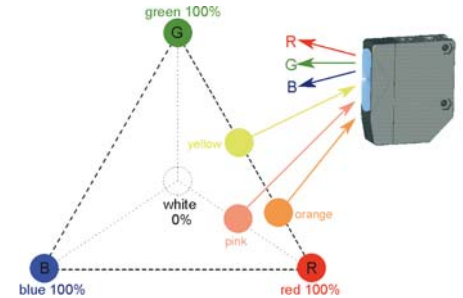

Color or chromatic sensors have a proximity function with generally three RGB LEDs for light emission. The color of an object is identified according to the different reflection coefficients obtained with red (R), green (G) and blue (B) light emissions. More simply, yellow can be identified by R=50% G=50% B=0% reflections; orange by R=75% G=25% B=0% reflections; pink by R=50% G=0% B=0% reflections; but possible combinations are really infinite. Color sensors operate only on reflection ratios and are not influenced by light intensity, defined as 'brilliance' or 'luminance'. There is a wide range of applications, ranging from quality and process controls, to automatic material handling for identification, orientation and selection of objects according to color.

## Fiber Optic Sensors



Universal functions of through-beam and proximity sensors, as well as application functions ranging from contrast and luminescence to color detection, can be obtained using fiber optic sensors. The optical fibers can be thought of as cables that transport light and can be used to place the sensor's optics in small spaces, or to detect very small objects.

An optical fiber is composed of cylindrical glass (or a plastic core), surrounded by Teflon or Silicon coating. The difference between the core and the coating refraction indexes allows the light to be diffused inside the fiber in a guided manner. The coating is covered by a plastic or metal sheath, which has an exclusively mechanical protection function. Fibers with a glass core and metal sheath are suitable for very high temperature uses, or for particular mechanical requirements. Plastic fibers, offering great adaptability, are the most diffused in all

PLCs

applications. Plastic optic fibers have a standard 2.2mm external diameter and generally have a cylindrical threaded metal head on the end used for mechanical mounting. These fibers are usually 1 and 2 meters in length as reductions in performance become significant with lengths over 5 meters. Plastic optic fibers can be shortened using a special fiber-cutting tool, but, it can only be used a limited number of times. Cutting the fiber with a non-sharp or non-perpendicular blade will reduce operating distance. High temperature, extra-flexible or high efficiency plastic optic fibers are also available.

Operator Interfaces



Automation Software

**Laser Sensors**

A LASER (Light Amplification by Stimulated Emission of Radiation) is an electronic device, such as a diode, that converts an energy source into a very thin and concentrated light beam, suitable for detecting very small objects or to reach very long operating distances. With reference to the safety of laser radiation (according to the EN60825-1 European standard) class 1 requires that the laser device is safe under reasonable operating conditions and is not dangerous for people in any situation; while class 2 states that the eye cannot be protected just by looking away or blinking, thus precautions must be adopted to avoid staring into the beam.



Power Supplies

**IMPORTANT:** Always consider safety when installing a laser sensor of any kind. Make sure that the laser beam cannot inadvertently shine into the eyes of people passing by or working in the vicinity. See safety information on page 232.

**Mounting**

Mounting brackets and hardware are included with sensors, where applicable. Use the hardware for mounting, along with washers and spring washers or lock nuts. Do not overtighten hardware. Overtightening causes damage to the housing and will adversely affect the waterproof characteristics of the sensor.

Best results can be obtained when the sensor is mounted so that the object sensed is in the center of the beam, rather than when the object is located near the edges of the sensing window. In addition, the most reliable sensing occurs when the majority of the objects being sensed are well within the sensing range, rather than at the extreme near and far limits.

**Wiring**

Avoid running high-voltages or power lines in the same conduit with sensor signal lines. This prevents inaccurate results or damage from induced noise. Use a separate conduit when the influence of power lines or electromagnetic equipment may occur, particularly when the distance of the wiring is extended.

**IMPORTANT:** Connect the sensor cables and wires as noted in the individual Wiring sections. Failure to connect as shown in wiring diagrams will result in damage to the internal circuit.

Sensors

Communication & Networking

When extending sensor cables and wires, make sure to use cables equal or superior to that recommended in the individual specifications sections.

When wiring terminals, be sure to prevent contact between adjoining terminals. When using ring or fork lug terminals, use the insulated sleeve style only. Each sensor terminal can accept only one ring or fork lug terminal.

**Power Supply**

Noise resistance characteristics are improved when a sensor is grounded to the 0V power terminal. If the 0V power terminal is not at ground potential, use a ceramic 0.01µF capacitor which can withstand 250V AC minimum.



When using a switching power supply, be sure to ground the FG terminal to eliminate high-frequency noise. The power supply should include an insulating transformer, not an autotransformer.

The compact PS5R-A power supply is the perfect companion item for most IDEC sensors. This power supply is only 1.77" (45mm) wide, 3.15" (80mm) tall, and 2.76" (70mm) deep. Call an IDEC representative for more details.

Part Number	Output Ratings
PS5R-A12	12V DC, 0.62A
PS5R-A24	24V DC, 0.32A

**Miscellaneous**

Strong magnetic fields may detract from the accuracy of the sensing measurements. Avoid mounting a sensor directly to machinery, since the housing is connected to the electronic circuit ground of the sensor. If it is necessary to mount a sensor on machinery, use the insulating plate and sleeve provided.

## Glossary

**Attenuation:** Reduction of beam intensity as a result of environmental factors such as dust, humidity, steam, etc.

**Dark on:** Output energized when light is not detected by the receiving element. For through-beam sensors, light from the projector is not detected by the receiver when an object is present. For reflected light sensors, light is not detected when it is not reflected from an object surface.

**Diffuse-reflected light sensors:** Sensors that detect all scattered and re-reflected light. Light reflected from nearby surfaces, as well as the intended object surface, is detected. Diffuse-reflected light sensors are often called “proximity switches,” since they switch when any object is near. Also use to detect color contrast when colors reflect light intensity differently (green LED recommended for this application).

**EEPROM:** Acronym which stands for electronically erasable, programmable, read only memory.

**Excess gain:** Ratio of optical power available at a given projector-to-receiver range divided by the minimum optical power required to trigger the receiver.

**Extraneous light:** Incident light received by a sensor, not related to the presence or absence of an object being detected. Extraneous light is usually unwanted background light such as sunlight and incandescent lamps in close proximity.

**$\Delta E$ :** The measurement of color difference as a three-variable function, located on an XYZ axis of light, hue, and chroma values.

**Hysteresis:** The lag in response shown by an object in reacting to changes in the forces affecting it. Operating point and release point at different levels. For solid state sensors, this is accomplished electrically. For mechanical switches, it results from storing potential energy before the transition occurs.

**Light on:** Output energized when light is detected by the receiving element. For through-beam sensors, light from the projector is detected by the receiver when an object is not present. For reflected light sensors, light is detected when it is reflected from an object's surface.

**Linearity:** The measure of the extent to which a certain response is directly proportional to the applied excitation.

**NPN/PNP:** Types of open collector transistors. NPN is a sink transistor; output on establishes negative potential difference. PNP is a source transistor; output on establishes positive potential difference.

**Polarizing:** Filtering out all reflected light except that which is projected in one plane only. Polarized retro-reflected light sensors detect the light from corner-cube type reflectors when an object is not present.

**Reflected-light sensors:** Sensors with the projector and receiver in one housing. Light is projected by the light source, and reflected light is received by the optical surface. Includes diffuse-reflected, retro-reflected, limited-reflected, and spot-reflected sensors.

**Repeatability:** Ability of a sensor to reproduce output readings consistently when the same value is applied consecutively, in the same direction, for a specified number of cycles, or for a specified time duration.

**Resolution:** Overall dimension of the smallest object which can be detected (when sensing the presence of an object) or smallest increment of distance which can be distinguished with reliable results (when sensing the position of an object).

**Response time:** Time elapsed between input and output. Total response time is the sum of object detection, amplifier response, and output response times.

**Retro-reflective:** This type of reflected light sensor uses a special reflector to return projected light when an object is not present. Sensor detects the presence of an object when the light is reflected differently.

**Through-beam sensors:** Sensors with a separate projector and receiver. The light source from the projector is detected by the receiver, except when an object is present.

**Transient:** Undesirable surge of current (many times larger than normal current) for a very short period, such as during the start-up of an inductive motor.