



## 54VCXH162244

### Low voltage CMOS 16-bit bus buffer (3-state inverter) with 3.6V tolerant inputs and outputs

#### Features

- 1.65 to 3.6V inputs and outputs
- High speed:
  - $t_{PD} = 3.4\text{ns}$  at  $V_{CC} = 3.0$  to  $3.6\text{V}$
  - $t_{PD} = 3.8\text{ns}$  at  $V_{CC} = 2.3$  to  $2.7\text{V}$
- Power down protection on inputs and outputs
- Symmetrical output impedance:
  - $I_{OH} = I_{OL} = 12\text{mA}$  (Min) at  $V_{CC} = 3.0\text{V}$
  - $I_{OH} = I_{OL} = 8\text{mA}$  (Min) at  $V_{CC} = 2.3\text{V}$
- $26\Omega$  series resistors in outputs
- Operating voltage range:
  - $V_{CC}(\text{Opr}) = 1.65\text{V}$  to  $3.6\text{V}$
- Pin and function compatible with 54 SERIES H162244
- Bus hold provided on data inputs
- Cold spare function
- Latch-up performance exceeds  $300\text{mA}$  (JESD 17)
- ESD performance:
  - $\text{HBM} > 2000\text{V}$   
(MIL STD 883 method 3015);  $\text{MM} > 200\text{V}$
- $300\text{KRad}$  Mil1019.6 Condition A, (RHA QML qualification extension undergone)
- No SEL, no SEU under  $72\text{Mev/cm}^2/\text{mg}$  LET heavy ions irradiation
- QML qualified product
- SMD 5962-05210

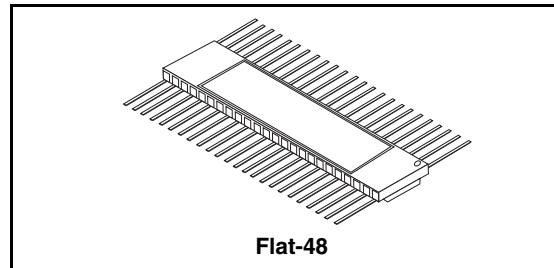

#### Description

The 54VCXH162244 is a low voltage CMOS 16 bit bus buffer (non inverted) fabricated with sub-micron silicon gate and five-layer metal wiring  $C^2$ MOS technology. It is ideal for low power and very high speed 1.65 to 3.6V applications; it can be interfaced to 3.6V signal environment for both inputs and outputs.

Any  $\overline{nG}$  output control governs four BUS buffers. Output Enable input ( $\overline{nG}$ ) tied together gives full 16-bit operation.

When  $\overline{nG}$  is low, the outputs are on. When  $\overline{nG}$  is HIGH, the output are in high impedance state.

This device is designed to be used with 3 state memory address drivers, etc. Bus hold on data inputs is provided in order to eliminate the need for external pull-up or pull-down resistor.

The device circuits is including  $26\Omega$  series resistance in the outputs. These resistors permit to reduce line noise in high speed applications.

All inputs and outputs are equipped with protection circuits against static discharge, giving them  $2\text{KV}$  ESD immunity and transient excess voltage.

---

# Contents

<b>1</b>	<b>Logic symbols and I/O equivalent circuit</b>	<b>3</b>
<b>2</b>	<b>Pin settings</b>	<b>4</b>
2.1	Pin connection	4
2.2	Pin description	5
2.3	Truth table	5
<b>3</b>	<b>Maximum rating</b>	<b>6</b>
3.1	Recommended operating conditions	6
<b>4</b>	<b>Electrical characteristics</b>	<b>7</b>
<b>5</b>	<b>Test circuit</b>	<b>11</b>
<b>6</b>	<b>Waveforms</b>	<b>12</b>
<b>7</b>	<b>Package mechanical data</b>	<b>14</b>
<b>8</b>	<b>Order code</b>	<b>15</b>
<b>9</b>	<b>Revision history</b>	<b>16</b>

# 1 Logic symbols and I/O equivalent circuit

Figure 1. IEC logic symbols

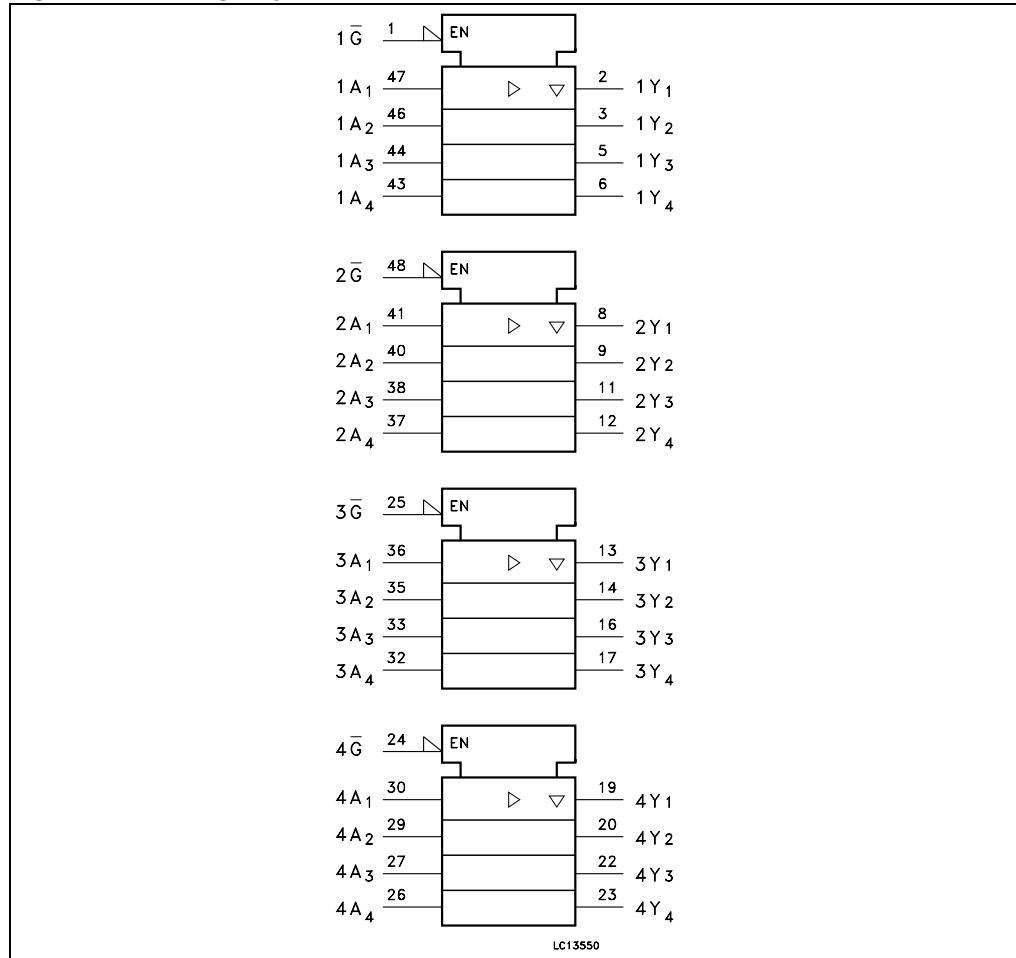
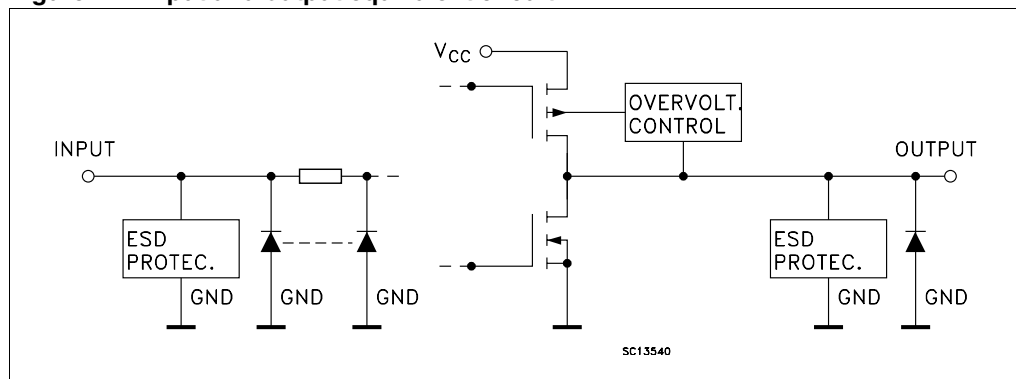

Figure 2. Input and output equivalent circuit



## 2 Pin settings

### 2.1 Pin connection

Figure 3. Pin connection (top through view)

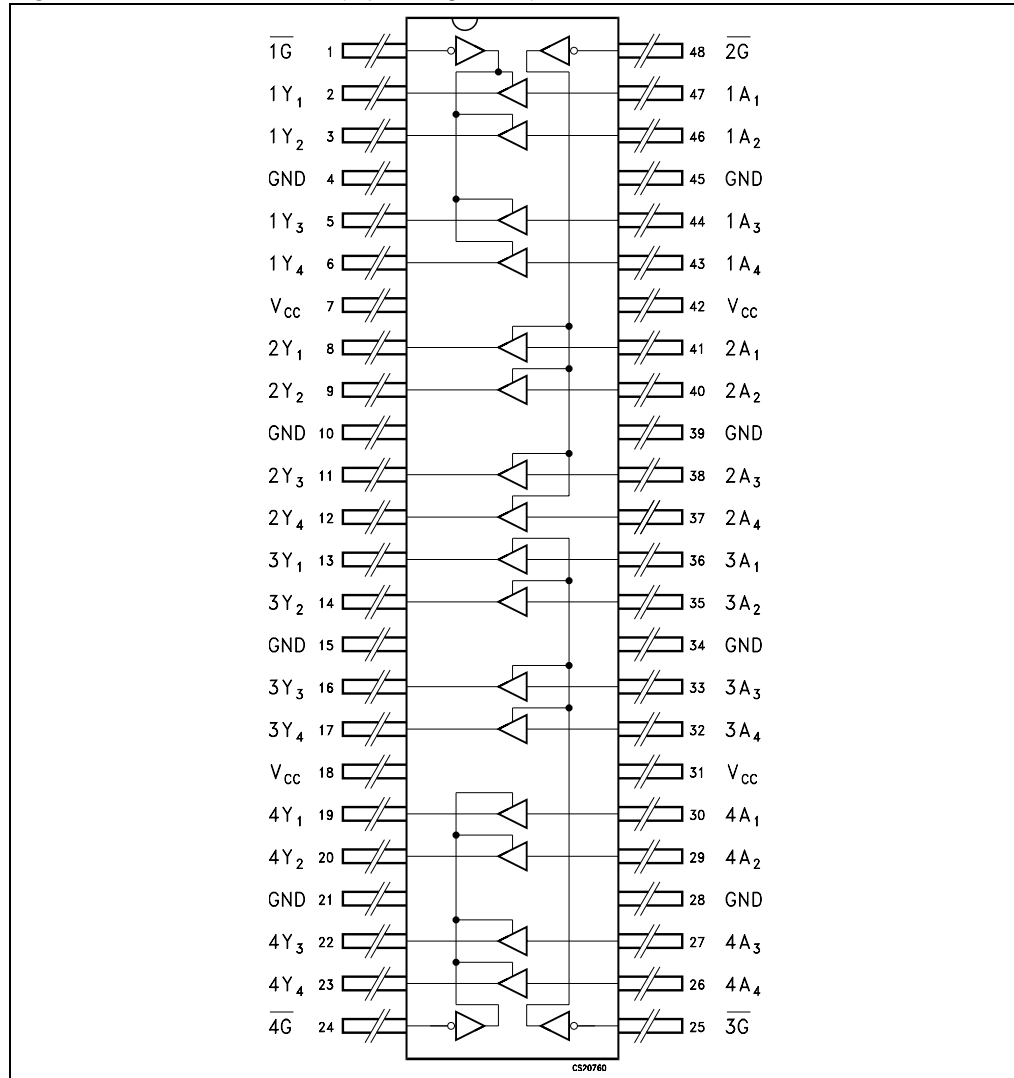

## 2.2 Pin description

Table 1. Pin description

Pin N°	Symbol	Name and function
1	$1\bar{G}$	Output enable input
2, 3, 5, 6	1Y1 to 1Y4	Data Outputs
8, 9, 11, 12	2Y1 to 2Y4	Data Outputs
13, 14, 16, 17	3Y1 to 3Y4	Data Outputs
19, 20, 22, 23	4Y1 to 4Y4	Data Outputs
24	$4\bar{G}$	Output Enable Input
25	$3\bar{G}$	Output Enable Input
30, 29, 27, 26	4A1 to 4A4	Data Outputs
36, 35, 33, 32	3A1 to 3A4	Data Outputs
41, 40, 38, 37	2A1 to 2A4	Data Outputs
47, 46, 44, 43	1A1 to 1A4	Data Outputs
48	$2\bar{G}$	Output Enable Input
4, 10, 15, 21, 28, 34, 39, 45	GND	Ground (0V)
7, 18, 31, 42	V <sub>CC</sub>	Positive Supply Voltage

## 2.3 Truth table

Table 2. Truth table

Inputs		Output
G	An	Yn
L	L	L
L	H	H
H	X	Z

Note: X = Do not care; Z = High Impedance

### 3 Maximum rating

Stressing the device above the rating listed in the “Absolute Maximum Ratings” table may cause permanent damage to the device. These are stress ratings only and operation of the device at these or any other conditions above those indicated in the Operating sections of this specification is not implied. Exposure to Absolute Maximum Rating conditions for extended periods may affect device reliability. Refer also to the STMicroelectronics SURE Program and other relevant quality documents.

**Table 3. Absolute maximum ratings**

Symbol	Parameter	Value	Unit
$V_{CC}$	Supply voltage	-0.5 to +4.6	V
$V_I$	DC input voltage	-0.5 to +4.6	V
$V_O$	DC output voltage (OFF State)	-0.5 to +4.6	V
$V_O$	DC output voltage (high or low state) <sup>(1)</sup>	-0.5 to $V_{CC} + 0.5$	V
$I_{IK}$	DC input diode current	- 50	mA
$I_{OK}$	DC output diode current <sup>(2)</sup>	- 50	mA
$I_O$	DC output current	$\pm 50$	mA
$I_{CC}$ or $I_{GND}$	DC $V_{CC}$ or ground current per supply pin	$\pm 100$	mA
$P_D$	Power dissipation	400	mW
$T_{stg}$	Storage temperature	-65 to +150	°C
$T_L$	Lead temperature (10 sec)	260	°C

1.  $I_O$  absolute maximum rating must be observed

2.  $V_O < GND$ ,  $V_O > V_{CC}$

#### 3.1 Recommended operating conditions

**Table 4. Recommended operating conditions**

Symbol	Parameter	Value	Unit
$V_{CC}$	Supply voltage	1.8 to 3.6	V
$V_I$	Input voltage	-0.3 to 3.6	V
$V_O$	Output voltage (OFF State)	0 to 3.6	V
$V_O$	Output voltage (High or Low State)	0 to $V_{CC}$	V
$I_{OH}$ , $I_{OL}$	High or low level output current ( $V_{CC} = 3.0$ to $3.6V$ )	$\pm 12$	mA
$I_{OH}$ , $I_{OL}$	High or low level output current ( $V_{CC} = 2.3$ to $2.7V$ )	$\pm 8$	mA
$T_{op}$	Operating temperature	-55 to 125	°C
dt/dv	Input rise and fall time <sup>(1)</sup>	0 to 10	ns/V

1.  $V_{IN}$  from 0.8V to 2V at  $V_{CC} = 3.0V$

## 4 Electrical characteristics

**Table 5. DC specifications** ( $2.7V < V_{CC} \leq 3.6V$  unless otherwise specified)

Symbol	Parameter	Test condition		Value		Unit
		V <sub>CC</sub> (V)		-55 to 125°C		
				Min	Max	
V <sub>IH</sub>	High level input voltage	2.7 to 3.6		2.0		V
V <sub>IL</sub>	Low level input voltage				0.8	
V <sub>OH</sub>	High level output voltage	2.7 to 3.6	I <sub>O</sub> = -100μA	V <sub>CC</sub> -0.2		V
		2.7	I <sub>O</sub> = -6mA	2.2		
		3.0	I <sub>O</sub> = -8mA	2.4		
			I <sub>O</sub> = -12mA	2.2		
V <sub>OL</sub>	Low level output voltage	2.7 to 3.6	I <sub>O</sub> = 100μA		0.2	V
		2.7	I <sub>O</sub> = 6mA		0.4	
		3.0	I <sub>O</sub> = 8mA		0.5	
			I <sub>O</sub> = 12mA		0.8	
I <sub>I</sub>	Input leakage current	2.7 to 3.6	V <sub>I</sub> = V <sub>CC</sub> or GND		± 5	μA
I <sub>I(HOLD)</sub>	Input hold current	3.0	V <sub>I</sub> = 0.8V	75		μA
			V <sub>I</sub> = 2V	-75		
		3.6	V <sub>I</sub> = 0 to 3.6V		± 500	
I <sub>off</sub>	Power off leakage current	0	V <sub>I</sub> or V <sub>O</sub> = 0 to 3.6V		10	μA
I <sub>OZ</sub>	High impedance output leakage current	2.7 to 3.6	V <sub>I</sub> = V <sub>IH</sub> or V <sub>IL</sub> V <sub>O</sub> = 0 to 3.6V		± 10	μA
I <sub>CC</sub>	Quiescent supply current	2.7 to 3.6	V <sub>I</sub> = V <sub>CC</sub> or GND		20	μA
			V <sub>I</sub> or V <sub>O</sub> = V <sub>CC</sub> to 3.6V		± 20	
ΔI <sub>CC</sub>	I <sub>CC</sub> incr. per Input	2.7 to 3.6	V <sub>IH</sub> = V <sub>CC</sub> - 0.6V		750	μA

Table 6. DC specifications ( $2.3V < V_{CC} \leq 2.7V$  unless otherwise specified)

Symbol	Parameter	Test condition		Value		Unit
		$V_{CC}$ (V)		-55 to 125 °C		
				Min	Max	
$V_{IH}$	High level input voltage	2.3 to 2.7		1.6		V
$V_{IL}$	Low level input voltage				0.7	
$V_{OH}$	High level output voltage	2.3 to 2.7	$I_O = -100 \mu A$	$V_{CC} - 0.2$		V
		2.3	$I_O = -4 \text{ mA}$	2.0		
			$I_O = -6 \text{ mA}$	1.8		
			$I_O = -8 \text{ mA}$	1.7		
$V_{OL}$	Low level output voltage	2.3 to 2.7	$I_O = 100 \mu A$		0.2	V
		2.3	$I_O = 6 \text{ mA}$		0.4	
			$I_O = 8 \text{ mA}$		0.6	
$I_I$	Input leakage current	2.3 to 2.7	$V_I = V_{CC}$ or GND		$\pm 5$	$\mu A$
$I_{I(HOLD)}$	Input hold current	2.3	$V_I = 0.7V$	45		$\mu A$
			$V_I = 1.7V$	-45		
$I_{off}$	Power off leakage current	0	$V_I$ or $V_O = 0$ to 3.6V		10	$\mu A$
$I_{OZ}$	High impedance output leakage current	2.3 to 2.7	$V_I = V_{IH}$ or $V_{IL}$ $V_O = 0$ to 3.6V		$\pm 10$	$\mu A$
$I_{CC}$	Quiescent supply current	2.3 to 2.7	$V_I = V_{CC}$ or GND		20	$\mu A$
			$V_I$ or $V_O = V_{CC}$ to 3.6V		$\pm 20$	



**Table 7. Dynamic switching characteristics**(T<sub>A</sub> = 25°C, Input t<sub>r</sub> = t<sub>f</sub> = 2.0ns, C<sub>L</sub> = 30pF, R<sub>L</sub> = 500Ω)

Symbol	Parameter	Test condition		Value			Unit
		V <sub>CC</sub> (V)		T <sub>A</sub> = 25 °C			
				Min	Typ	Max	
V <sub>OLP</sub>	Dynamic low voltage quiet output <sup>(1)</sup> <sup>(2)</sup>	2.5	V <sub>IL</sub> = 0V V <sub>IH</sub> = V <sub>CC</sub>		0.25		V
		3.3			0.35		
V <sub>OLV</sub>	Dynamic low voltage quiet output <sup>(1)</sup> <sup>(2)</sup>	2.5	V <sub>IL</sub> = 0V V <sub>IH</sub> = V <sub>CC</sub>		-0.25		V
		3.3			-0.35		
V <sub>OHV</sub>	Dynamic high voltage quiet output <sup>(2)</sup> <sup>(3)</sup>	2.5	V <sub>IL</sub> = 0V V <sub>IH</sub> = V <sub>CC</sub>		2.05		V
		3.3			2.65		

1. Number of outputs defined as "n". Measured with "n-1" outputs switching from HIGH to LOW or LOW to HIGH. The remaining output is measured in the LOW state.
2. Parameters guaranteed by design.
3. Number of outputs defined as "n". Measured with "n-1" outputs switching from HIGH to LOW or LOW to HIGH. The remaining output is measured in the HIGH state.

**Table 8. AC electrical characteristics** (C<sub>L</sub> = 30pF, R<sub>L</sub> = 500Ω, Input t<sub>r</sub> = t<sub>f</sub> = 2.0ns)

Symbol	Parameter	Test condition		Value		Unit
		V <sub>CC</sub> (V)		-55 to 125 °C		
				Min	Max	
t <sub>PLH</sub> t <sub>PHL</sub>	Propagation delay time	2.3 to 2.7		1.0	5.2	ns
		3.0 to 3.6		0.8	5.0	
t <sub>PZL</sub> t <sub>PZH</sub>	Output enable time	2.3 to 2.7		1.0	5.8	ns
		3.0 to 3.6		0.8	4.2	
t <sub>PLZ</sub> t <sub>PHZ</sub>	Output disable time	2.3 to 2.7		1.0	4.5	ns
		3.0 to 3.6		0.8	4.0	
t <sub>OSLH</sub> t <sub>OSHL</sub>	Output to output skew time <sup>(1)</sup> <sup>(2)</sup>	2.3 to 2.7			0.5	ns
		3.0 to 3.6			0.5	

1. Skew is defined as the absolute value of the difference between the actual propagation delay for any two outputs of the same device switching in the same direction, either HIGH or LOW (t<sub>OSLH</sub> = |t<sub>PLHm</sub> - t<sub>PLHn</sub>|, t<sub>OSHL</sub> = |t<sub>PHLm</sub> - t<sub>PHLn</sub>|)
2. Parameter guaranteed by design

Table 9. Capacitive characteristics

Symbol	Parameter	Test condition		Value			Unit
		V <sub>CC</sub> (V)		T <sub>A</sub> = 25 °C			
				Min	Typ	Max	
C <sub>IN</sub>	Input capacitance	2.5 or 3.3	V <sub>IN</sub> = 0 or V <sub>CC</sub>		6		pF
C <sub>OUT</sub>	Output capacitance	2.5 or 3.3	V <sub>IN</sub> = 0 or V <sub>CC</sub>		7		pF
C <sub>PD</sub>	Power dissipation capacitance <sup>(1)</sup>	2.5 or 3.3	f <sub>IN</sub> = 10MHz V <sub>IN</sub> = 0 or V <sub>CC</sub>		20		pF

1. C<sub>PD</sub> is defined as the value of the IC's internal equivalent capacitance which is calculated from the operating current consumption without load. (Refer to Test Circuit). Average operating current can be obtained by the following equation.  $I_{CC(opr)} = C_{PD} \times V_{CC} \times f_{IN} + I_{CC}/16$  (per circuit)

## 5 Test circuit

Figure 4. Test circuit

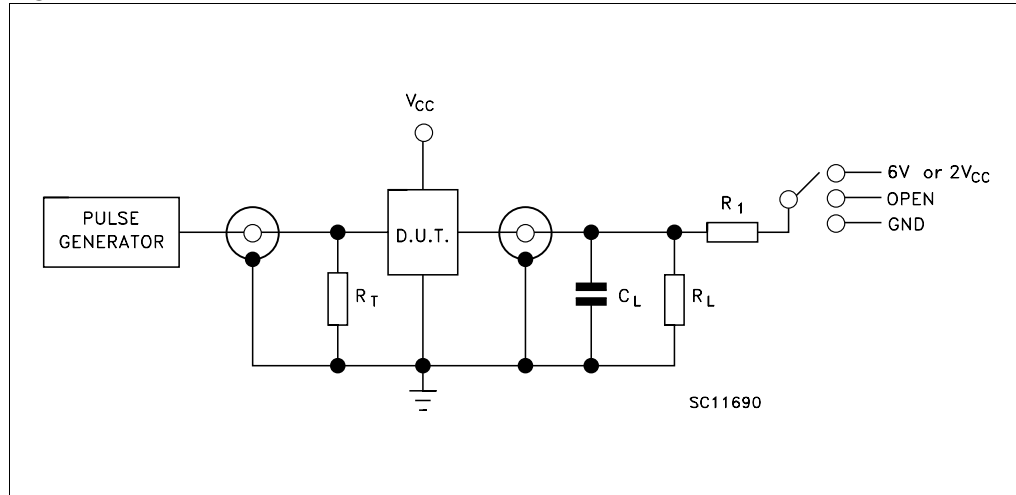

Table 10. Test circuit

Test	Switch
$t_{PLH}$ , $t_{PHL}$	Open
$t_{PZL}$ , $t_{PLZ}$ ( $V_{CC} = 3.0$ to $3.6V$ )	6V
$t_{PZL}$ , $t_{PLZ}$ ( $V_{CC} = 2.3$ to $2.7V$ )	$2V_{CC}$
$t_{PZH}$ , $t_{PHZ}$	GND

$C_L = 10/30pF$  or equivalent (includes jig and probe capacitance)

$R_L = R_T = 500\Omega$  or equivalent

$R_T = Z_{OUT}$  of pulse generator (typically  $50\Omega$ )

## 6 Waveforms

Table 11. Waveform symbol value

Symbol	$V_{CC}$	
	3.0 to 3.6V	2.3 to 2.7V
$V_{IH}$	2.7V	$V_{CC}$
$V_M$	1.5V	$V_{CC}/2$
$V_X$	$V_{OL} + 0.3V$	$V_{OL} + 0.15V$
$V_Y$	$V_{OH} - 0.3V$	$V_{OH} - 0.15V$

Figure 5. Waveform - propagation delay ( $f = 1\text{MHz}$ ; 50% duty cycle)

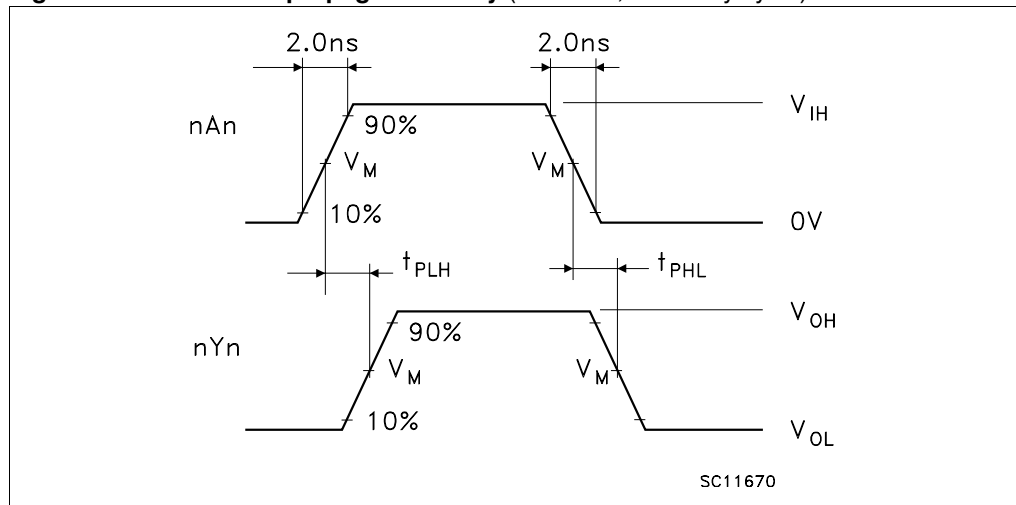
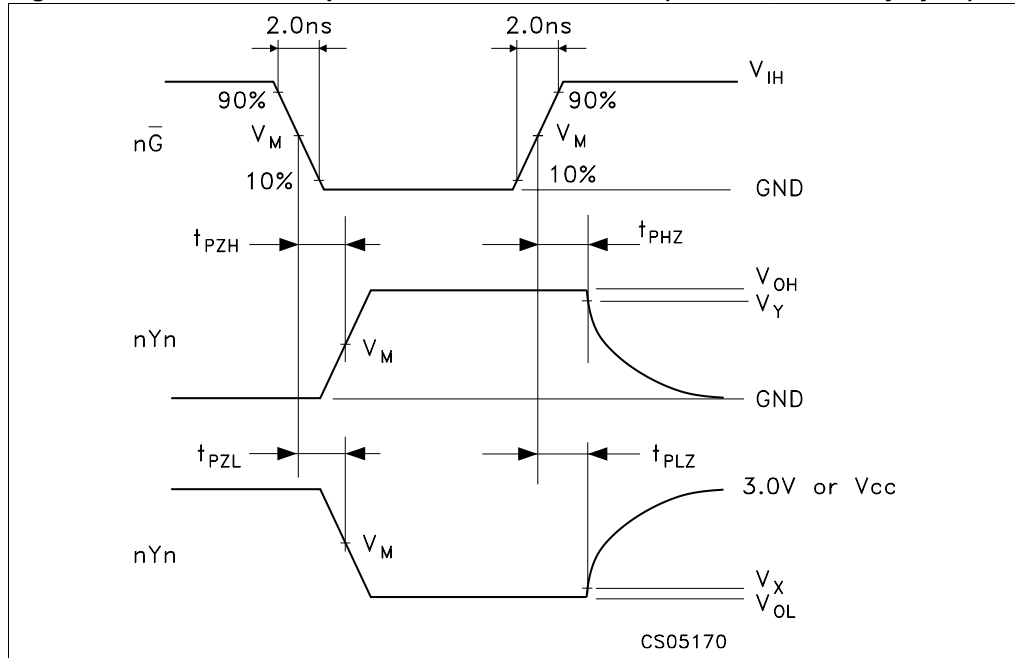

Figure 6. Waveform - output enable and disable time (f = 1MHz; 50% duty cycle)



## 7 Package mechanical data

54VCXH162245 Products are supplied into ceramic body / metal lid hermetic Flat 48-pin space package

**Table 12. Flat-48 (MIL-STD-1835) mechanical data**

Dim.	mm			inch		
	Min	Typ	Max	Min	Typ	Max
A	2.18	2.47	2.72	0.086	0.097	0.107
b	0.20	0.254	0.30	0.008	0.010	0.012
c	0.12	0.15	0.18	0.005	0.006	0.007
D	15.57	15.75	15.92	0.613	0.620	0.627
E	9.52	9.65	9.78	0.375	0.380	0.385
E2	6.22	6.35	6.48	0.245	0.250	0.255
E3	1.52	1.65	1.78	0.060	0.065	0.070
e		0.635			0.025	
f		0.20			0.008	
L	6.85	8.38	9.40	0.270	0.330	0.370
Q	0.66	0.79	0.92	0.026	0.031	0.036
S1	0.25	0.43	0.61	0.010	0.017	0.024

**Figure 7. Package dimension**

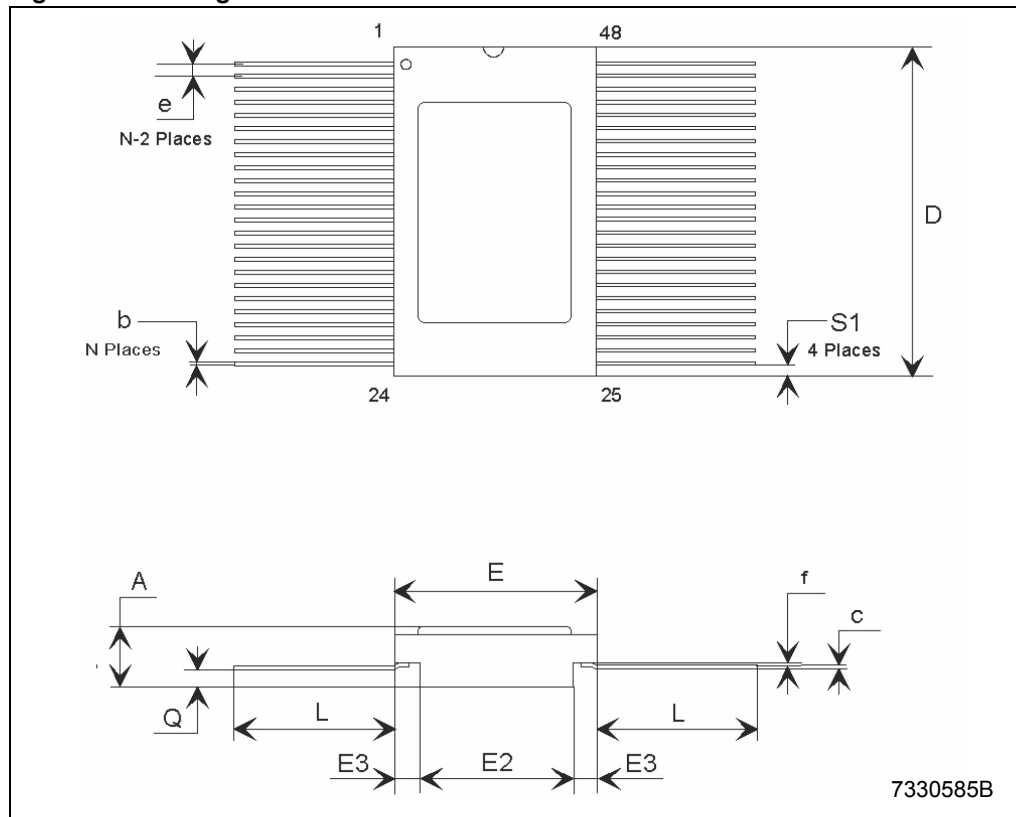

## 8 Order code

**Table 13. Order code**

Package	Lead finish	Radiation level	Flight model		Engineering model
			QML-V	QML-Q	
Flat-48	Gold	300kRad	RHFXH162244K-01V	RHFXH162244K-01Q	RHRXH162244K1
	Gold	100kRad	RHRXH162244K-01V	RHRXH162244K-01Q	RHRXH162244K1
	Solder dip	100kRad	RHRXH162244K-02V	RHRXH162244K-02Q	Use the above one

## 9 Revision history

Table 14. Revision history

Date	Revision	Changes
09-Jul-2004	1	First Release
17-May-2005	2	SMD Qualified.
19-Jun-2006	3	300Krad bullet updated, new template, mechanical data updated
11-Apr-2007	4	Updated coverpage features
30-Jul-2007	5	Typo in <a href="#">Table 12 on page 14</a>



**Please Read Carefully:**

Information in this document is provided solely in connection with ST products. STMicroelectronics NV and its subsidiaries ("ST") reserve the right to make changes, corrections, modifications or improvements, to this document, and the products and services described herein at any time, without notice.

All ST products are sold pursuant to ST's terms and conditions of sale.

Purchasers are solely responsible for the choice, selection and use of the ST products and services described herein, and ST assumes no liability whatsoever relating to the choice, selection or use of the ST products and services described herein.

No license, express or implied, by estoppel or otherwise, to any intellectual property rights is granted under this document. If any part of this document refers to any third party products or services it shall not be deemed a license grant by ST for the use of such third party products or services, or any intellectual property contained therein or considered as a warranty covering the use in any manner whatsoever of such third party products or services or any intellectual property contained therein.

**UNLESS OTHERWISE SET FORTH IN ST'S TERMS AND CONDITIONS OF SALE ST DISCLAIMS ANY EXPRESS OR IMPLIED WARRANTY WITH RESPECT TO THE USE AND/OR SALE OF ST PRODUCTS INCLUDING WITHOUT LIMITATION IMPLIED WARRANTIES OF MERCHANTABILITY, FITNESS FOR A PARTICULAR PURPOSE (AND THEIR EQUIVALENTS UNDER THE LAWS OF ANY JURISDICTION), OR INFRINGEMENT OF ANY PATENT, COPYRIGHT OR OTHER INTELLECTUAL PROPERTY RIGHT.**

**UNLESS EXPRESSLY APPROVED IN WRITING BY AN AUTHORIZED ST REPRESENTATIVE, ST PRODUCTS ARE NOT RECOMMENDED, AUTHORIZED OR WARRANTED FOR USE IN MILITARY, AIR CRAFT, SPACE, LIFE SAVING, OR LIFE SUSTAINING APPLICATIONS, NOR IN PRODUCTS OR SYSTEMS WHERE FAILURE OR MALFUNCTION MAY RESULT IN PERSONAL INJURY, DEATH, OR SEVERE PROPERTY OR ENVIRONMENTAL DAMAGE. ST PRODUCTS WHICH ARE NOT SPECIFIED AS "AUTOMOTIVE GRADE" MAY ONLY BE USED IN AUTOMOTIVE APPLICATIONS AT USER'S OWN RISK.**

Resale of ST products with provisions different from the statements and/or technical features set forth in this document shall immediately void any warranty granted by ST for the ST product or service described herein and shall not create or extend in any manner whatsoever, any liability of ST.

ST and the ST logo are trademarks or registered trademarks of ST in various countries.

Information in this document supersedes and replaces all information previously supplied.

The ST logo is a registered trademark of STMicroelectronics. All other names are the property of their respective owners.

© 2007 STMicroelectronics - All rights reserved

STMicroelectronics group of companies

Australia - Belgium - Brazil - Canada - China - Czech Republic - Finland - France - Germany - Hong Kong - India - Israel - Italy - Japan - Malaysia - Malta - Morocco - Singapore - Spain - Sweden - Switzerland - United Kingdom - United States of America

[www.st.com](http://www.st.com)

