

RB520S

List

List..... 1

Package outline..... 2

Features..... 2

Mechanical data..... 2

Maximum ratings 2

Rating and characteristic curves..... 3

Pinning information.....4

Marking..... 4

Suggested solder pad layout..... 4

Packing information..... 5

Reel packing..... 6

Suggested thermal profiles for soldering processes..... 6

High reliability test capabilities.....7



Document ID	Issued Date	RevisedDate	Revision	Page.
DS-221674	2008/02/10	-	A	7

RB520S

200mA Surface Mount Small Signal Type-30V

Features

- Low current rectification and high speed switching.
- Extremely small surface mount type.
- Up to 200mA current capability.
- Low forward voltage drop ($V_F = 0.6V$ typ. @200mA)
- Silicon epitaxial planar chip, metal silicon junction.
- Lead-free parts meet/exceeds environmental standards of MIL-STD-19500/228

Mechanical data

- Epoxy: UL94-V0 rated flame retardant
- Case : Molded plastic, SOD-523FL
- Terminals : Solder plated, solderable per MIL-STD-750, Method 2026
- Polarity : Indicated by cathode band
- Mounting Position : Any
- Weight : Approximated 0.002gram

Package outline

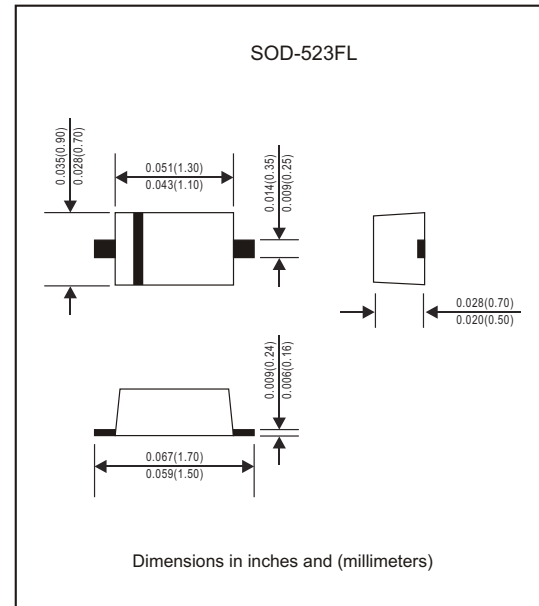

Maximum ratings (AT $T_A = 25^\circ C$ unless otherwise noted)

PARAMETER	CONDITIONS	Symbol	MIN.	TYP.	MAX.	UNIT
Repetitive peak reverse voltage		V_{RM}			30	V
Continuous reverse voltage		V_R			30	V
Mean rectifying current		I_O			200	mA
Forward surge current	8.3ms single halfsine-wave superimposed on rate load (JEDEC methode)	I_{FSM}			1000	mA
Capacitance between terminals	f=1MHz and applied 10V DC reverse voltage	C_T		4		pF
Storage temperature		T_{STG}	-65		+175	$^\circ C$
Operating temperature		T_J	-55		+125	$^\circ C$
Forward voltage	$I_F = 200$ mADC	V_F			0.60	V
Reverse current	$V_R = 10$ V DC	I_R			1.0	μA

RATING AND CHARACTERISTIC CURVES (RB520S)

FIG.1-TYPICAL FORWARD CHARACTERISTICS

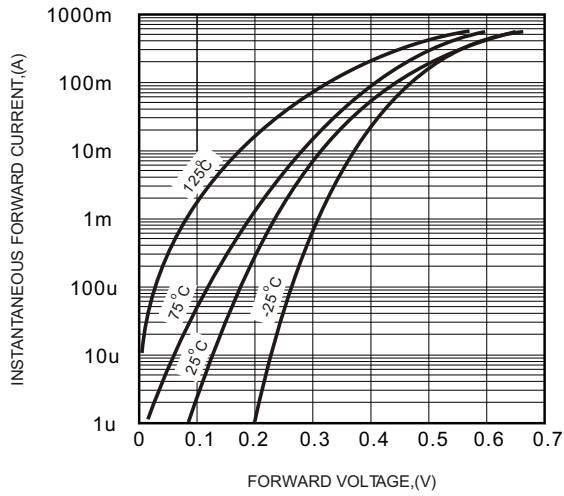

FIG.2 - TYPICAL REVERSE CHARACTERISTICS

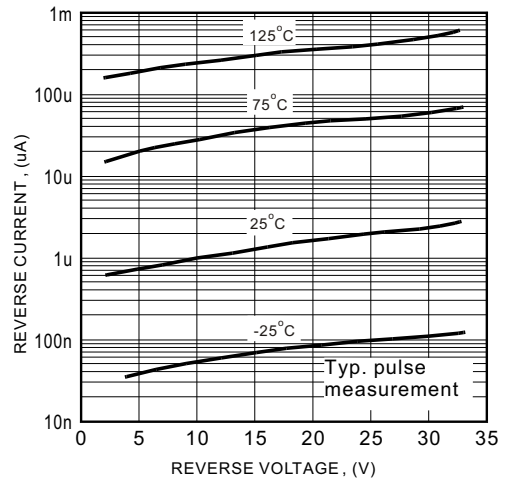
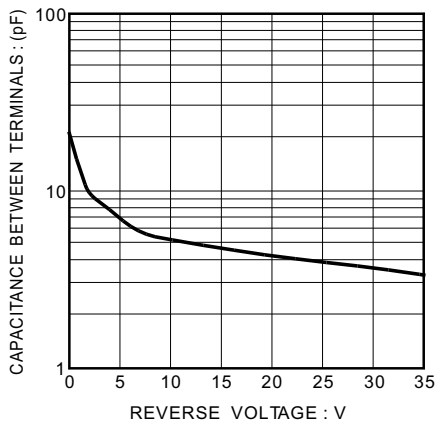

FIG.3-TYPICAL TERMINALS CAPACITANCE



RB520S

Pinning information

Pin	Simplified outline	Symbol
Pin1 cathode Pin2 anode		

Marking

Type number	Marking code
RB520S	B , 5J

Suggested solder pad layout

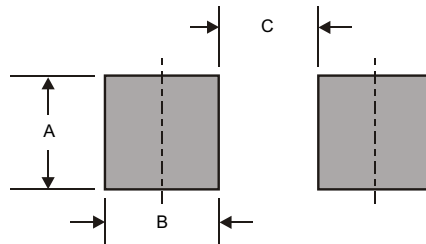

Dimensions in inches and (millimeters)

PACKAGE	A	B	C
SOD-523FL	0.016 (0.40)	0.016 (0.40)	0.056 (1.40)

RB520S

Packing information

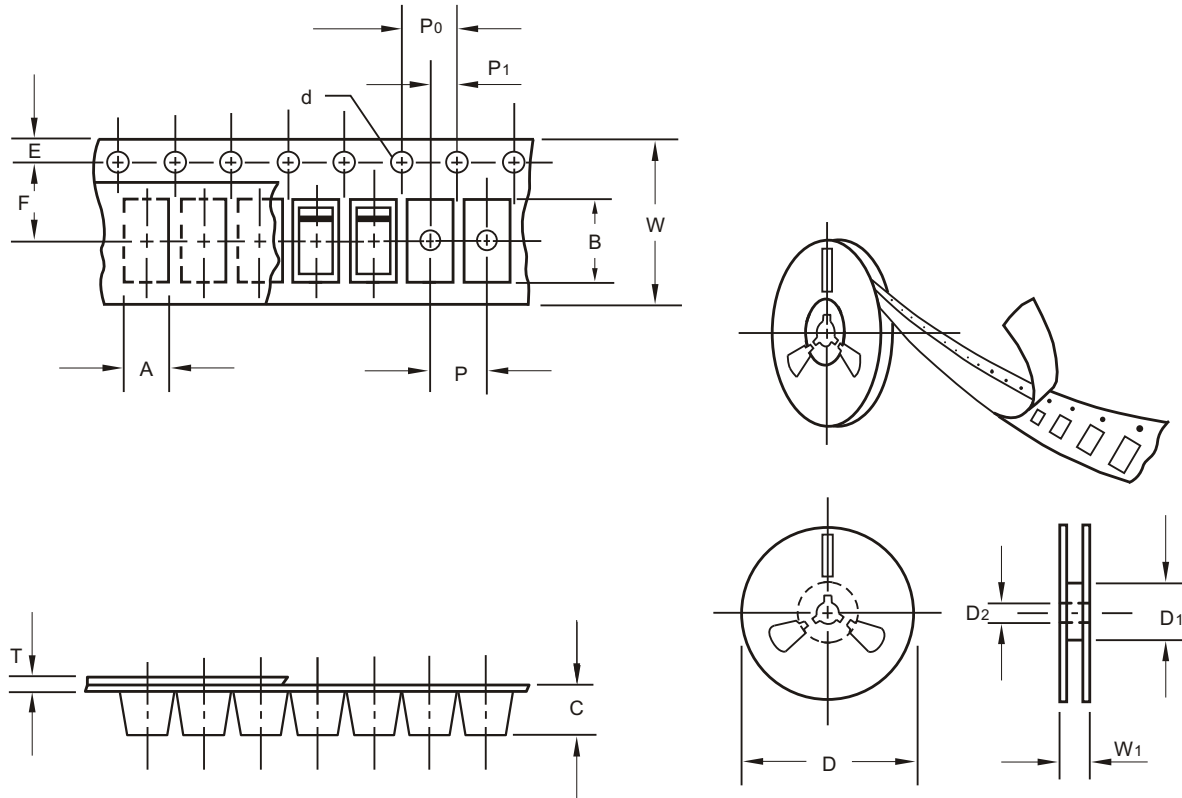

unit:mm

Item	Symbol	Tolerance	SOD-523FL
Carrier width	A	0.1	0.90
Carrier length	B	0.1	1.40
Carrier depth	C	0.1	0.76
Sprocket hole	d	0.1	1.50
7" Reel outside diameter	D	2.0	178.00
7" Reel inner diameter	D ₁	min	50.00
Feed hole diameter	D ₂	0.5	8.40~9.90
Sprocket hole position	E	0.1	1.75
Punch hole position	F	0.1	3.50
Punch hole pitch	P	0.1	4.00
Sprocket hole pitch	P ₀	0.1	4.00
Embossment center	P ₁	0.1	2.00
Overall tape thickness	T	0.1	0.23
Tape width	W	0.3	8.00
Reel width	W ₁	1.0	10.90

Note: Devices are packed in accordance with EIA standard RS-481-A and specifications listed above.

RB520S

Reel packing

PACKAGE	REEL SIZE	REEL (pcs)	COMPONENT SPACING (m/m)	BOX (pcs)	INNER BOX (m/m)	REEL DIA, (m/m)	CARTON SIZE (m/m)	CARTON (pcs)	APPROX. GROSS WEIGHT (kg)
SOD-523FL	7"	3000	4.0	30,000	195*190*140	178	360*355*227	120,000	4.3
							400*300*410	240,000	7.8
							450*395*420	360,000	11.6

Suggested thermal profiles for soldering processes

- 1.Storage environment: Temperature=10°C~35°C Humidity=65%±15%
- 2.Reflow soldering of surface-mount devices

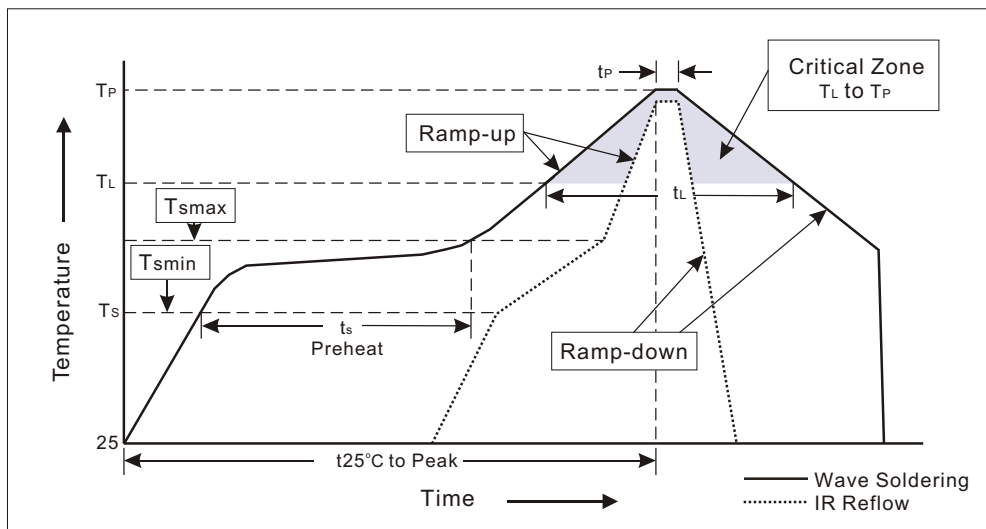

3.Flow (wave)soldering (solder dipping)

Profile Feature	Soldering Condition
Average ramp-up rate(T_L to T_P)	<3°C/sec
Preheat -Temperature Min(T_{smin}) -Temperature Max(T_{smax}) -Time(min to max)(t_s)	100°C 150°C 60~120sec
T_{smax} to T_L -Ramp-upRate	<3°C/sec
Time maintained above: -Temperature(T_L) -Time(t_L)	183°C 60~150sec
Peak Temperature(T_P)	255°C-0/+5°C
Time within 5°C of actual Peak Temperature(t_p)	10~30sec
Ramp-down Rate	<6°C/sec
Time 25°C to Peak Temperature	<6minutes

RB520S**High reliability test capabilities**

Item Test	Conditions	Reference
1. Solder Resistance	at 260±5°C for 10±2sec. immerse body into solder 1/16"±1/32"	MIL-STD-750D METHOD-2031
2. Solderability	at 245±5°C for 5 sec.	MIL-STD-202F METHOD-208
3. High Temperature Reverse Bias	$V_R=80\%$ rate at $T_A=125^\circ\text{C}$ for 168 hrs.	MIL-STD-750D METHOD-1026
4. Forward Operation Life	Rated average rectifier current at $T=25^\circ\text{C}$ for 500hrs.	MIL-STD-750D METHOD-1027
5. Intermittent Operation Life	$T_A = 25^\circ\text{C}$, $I_F = I_O$ On state: power on for 5 min. off state: power off for 5 min. on and off for 500 cycles.	MIL-STD-750D METHOD-1036
6. Pressure Cooker	$15P_{SIG}$ at $T_A=121^\circ\text{C}$ for 4 hrs.	
7. Temperature Cycling	-55°C to +125°C dwelled for 30 min. and transferred for 5 min. total 10 cycles.	MIL-STD-750D METHOD-1051
8. Thermal Shock	0°C for 5 min. rise to 100°C for 5 min. total 10 cycles.	MIL-STD-750D METHOD-1056
9. Forward Surge	8.3ms single half sine-wave superimposed on rated load, one surge.	MIL-STD-750D METHOD-4066-2
10. Humidity	at $T_A=65^\circ\text{C}$, RH=98% for 1000hrs.	MIL-STD-750D METHOD-1038
11. High Temperature Storage Life	at 175°C for 1000 hrs.	MIL-STD-750D METHOD-1031
12. Solvent Resistance	Dip into Freon at 25°C for 1 min.	MIL-STD-202F METHOD-215