

UNCONTROLLED DOCUMENT

PART NUMBER
SSB-DL6613UWC/B

REV.
B

REV.	E.C.N. NUMBER AND REVISION COMMENTS	DATE
A	E.C.N. #10988.	5.9.03
B	E.C.N. #11148.	5.11.07

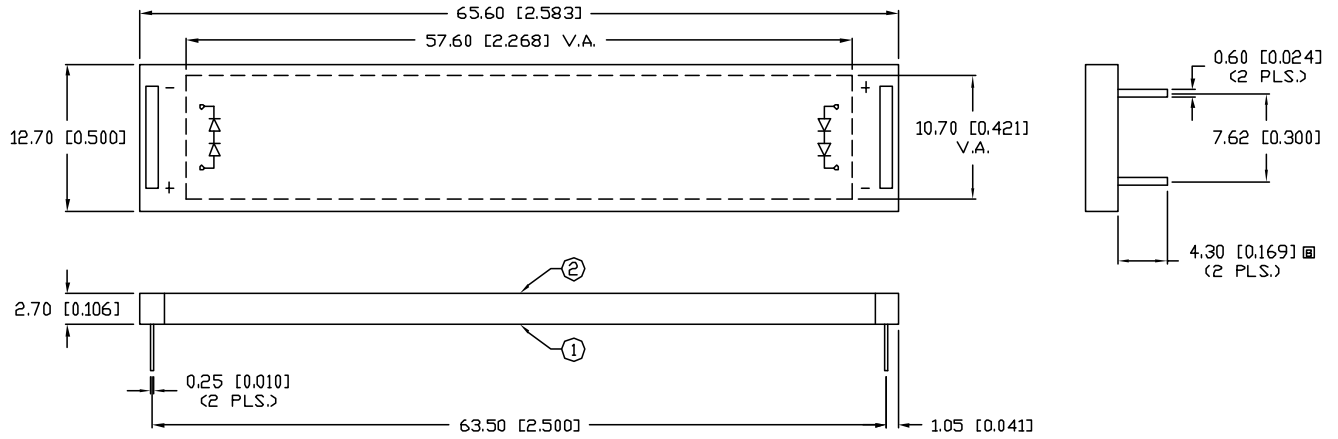

ELECTRO-OPTICAL CHARACTERISTICS $T_A=25^\circ\text{C}$ PER MODULE					$I_f=20\text{ mA}$
PARAMETER	MIN	TYP	MAX	UNITS	TEST COND
PEAK WAVELENGTH		550 (WHITE)		nm	
FORWARD VOLTAGE		7.2	8.0	V_f	
REVERSE VOLTAGE	10			V_r	$V_r=100\mu\text{A}$
LUMINOUS INTENSITY		350		cd/m^2	$I_f=20\text{ mA}$
EMITTED COLOR:	WHITE				
REFLECTOR FINISH:	CLEAR WITH FROSTED BOTTOM				

LIMITS OF SAFE OPERATION AT 25°C PER LED		
PARAMETER	MAX	UNITS
PEAK FORWARD CURRENT*	100	mA
STEADY CURRENT	30	mA
POWER DISSIPATION	120	W
DERATE FROM 25°C	-1.2	$\text{mW}/^\circ\text{C}$
OPERATING TEMP.	-20 TO +70	$^\circ\text{C}$
STORAGE TEMP.	-30 TO +80	$^\circ\text{C}$
SOLDERING TEMP.	+260	$^\circ\text{C}$
2.0mm FROM BODY		3 SEC. MAX
* $t < 10\mu\text{s}$		

NOTES:

1. BOTTOM REFLECTOR TAPE.
2. TOP DIFFUSER TAPE.

*UNLESS OTHERWISE SPECIFIED TOLERANCES PER DECIMAL PRECISION ARE: X=±1 (±0.039), XX=±0.5 (±0.020), XXX=±0.25 (±0.010), XXXX=±0.127 (±0.005). LEAD SIZE=±0.05 (±0.002), LEAD LENGTH=±0.75 (±0.030). MIN.= +DECIMAL PRECISION -0.000 MAX.= +0.000 -DECIMAL PRECISION

UNCONTROLLED DOCUMENT



REV.	PART NUMBER
B	SSB-DL6613UWC/B

66mm x 13mm LCD BACKLIGHT, DUAL SIDED, WHITE CHIPS,
CLEAR LENS WITH MILKY WHITE DIFFUSER.

CONFIDENTIAL INFORMATION
THE INFORMATION CONTAINED IN THIS DOCUMENT IS THE PROPERTY OF LUMEX INC. EXCEPT AS SPECIFICALLY AUTHORIZED IN WRITING BY LUMEX INC., THE HOLDER OF THIS DOCUMENT SHALL KEEP ALL INFORMATION CONTAINED HEREIN CONFIDENTIAL AND SHALL PROTECT SAME IN WHOLE OR IN PART FROM DISCLOSURE AND DISSEMINATION TO ALL THIRD PARTIES.

RELIABILITY NOTE
OUR MANY YEARS OF EXPERIENCE DATA ACCUMULATION INDICATE THAT SOLDER HEAT IS A MAJOR CAUSE OF EARLY AND FUTURE FAILURE. PLEASE PAY ATTENTION TO YOUR SOLDERING PROCESS.



290 E. HELEN ROAD
PALATINE, IL 60067-6976
PHONE: +1.847.359.2790
US WEB: www.lumex.com
TW WEB: www.lumex.com.tw

DRAWN BY: JC	CHECKED BY:	APPROVED BY:	DATE: 8.15.02
			PAGE: 1 OF 1
			SCALE: N/A