

# 0.4 mm Pitch, 1.5 mm Mated Height, Board-to-Fine Coaxial Cable Connectors

## DF36 Series

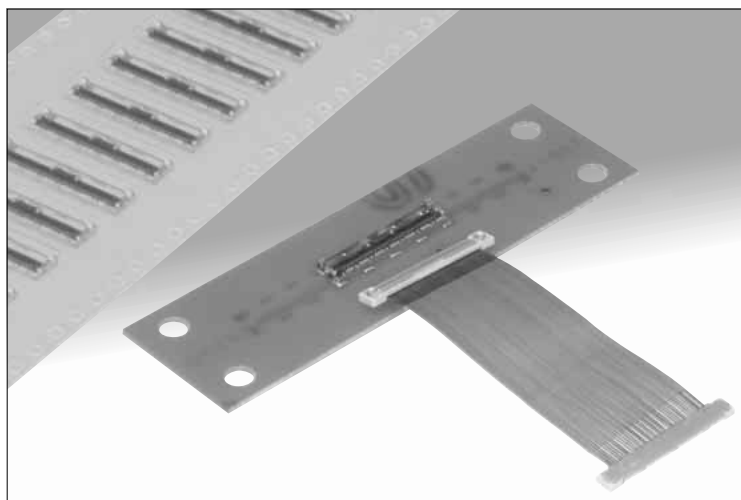

**High contact reliability –  
Effective mating length of 0.4 mm**

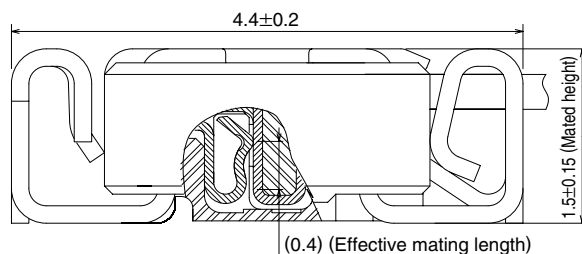

### ■ Features

#### 1. Small mated height and board occupied space

Small pitch (0.4mm) and mated height (1.5mm) allows use in space-restricted areas.

Plug's height of 1.33mm and width of 2.8 mm allow its passage through narrow openings in small-diameter hinge applications.

#### 2. Enhanced shielding and ground connections

Metal covers on the plug and receptacle connect to each other with a reliable multi-point ground contacts, assuring reliable ground connection and EMC protection.

#### 3. Reliable lock

Fully mated condition is assured with reliable locks at 4 locations, confirming it with a distinct tactile click.

#### 4. Reliable electrical and mechanical connection

Despite its small mated height, unique contact configuration assures highly reliable connection, with effective mating length of 0.4 mm.

#### 5. Solder wicking prevention

Nickel barriers prevent solder wicking in the critical contact areas.

#### 6. Durable plug construction

Formed metal shells on the top and side surfaces form a strong and rigid assembly.

#### 7. RoHS compliant

All components and materials comply with the requirements of EU Directive 2002/95/EC.

### ■ Applications

Mobile phones, digital cameras, digital camcorders and other thin portable devices requiring high-speed reliable connection with a fine coaxial cable.

### Enhanced shielding

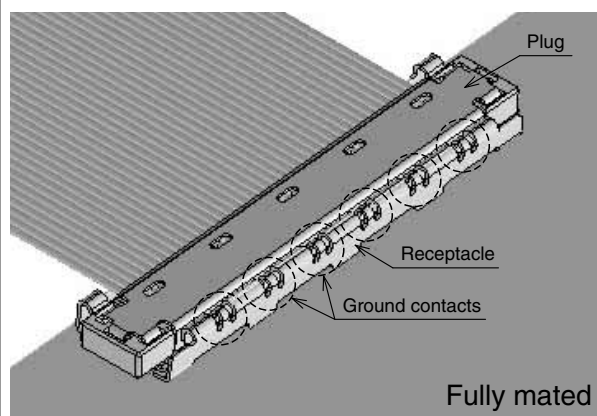

### Multi-point contacts

### 4-point lock: 2 points at each end

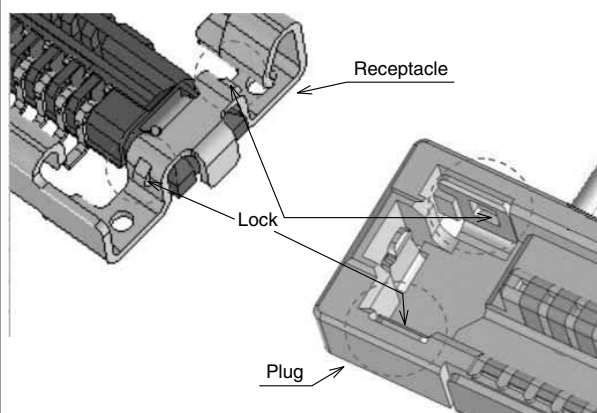

### Distinct tactile click

## DF36 Series 0.4 mm Pitch, 1.5 mm Mated Height, Board-to-Fine Coaxial Cable Connectors

### Product Specifications

Ratings	Current rating	0.25 A (AWG #42)	Operating temperature range Operating humidity range	-35 to +85°C (Note 1) 20 to 80%
	Voltage rating	30 V AC	Storage temperature range Storage humidity range	-10 to +60°C (Note 2) 40 to 70% (Note 2)

Item	Specification	Conditions
1. Insulation resistance	50 MΩ min	100 V DC
2. Withstanding voltage	No flashover or insulation breakdown	100 V AC / one minute
3. Contact resistance	Signal: 80 mΩ max., Ground: 80 mΩ max.	100 mA (DC or 1,000 Hz)
4. Vibration	No electrical discontinuity of 1 μs or longer No damage, cracks or parts dislocation.	Frequency: 10 to 55 Hz, single amplitude of 0.75 mm, 10 cycles in each of the 3 axial directions
5. Humidity	Contact resistance (Change from initial value) 50 mΩ max. Insulation resistance: 25 MΩ min. No damage, cracks or parts dislocation.	96 hours at 40 ±2°C, and humidity of 90 to 95%
6. Temperature cycle	Contact resistance (Change from initial value) 50 mΩ max. Insulation resistance: 25 MΩ min. No damage, cracks or parts dislocation.	Temperature: -55°C → 5 to 35°C → 85°C → 5 to 35°C Time: 30 min. → 2 to 3 min. → 30 min. → 2 to 3 min. 5 cycles
7. Durability	Contact resistance (Change from initial value) 50 mΩ max. No damage, cracks or parts dislocation.	30 cycles
8. Resistance to soldering heat	No deformation of components affecting performance.	Reflow: At the recommended temperature profile Manual soldering: 350°C for 3 seconds

Note 1: Includes temperature rise caused by current flow.

Note 2: The term "storage" refers to products stored for a long period prior to mounting and use.

The operating temperature and humidity range covers the non-conducting condition of connectors after board mounting and the temporary storage conditions of transportation, etc.

Note 3: Information contained in this catalog represents general requirements for this Series. Contact us for the drawings and specifications for a specific part number shown.

### Materials

Item	Part	Material	Finish	Remarks
Receptacle (Standard)	Insulator	LCP	Color: Black	UL94V-0
	Contacts	Phosphor bronze	Gold plated	—
	Metal cover	Phosphor bronze	Tin plated	—
Plug (Standard)	Insulator	LCP	Color: Natural (Beige)	UL94V-0
	Contacts	Phosphor bronze	Gold plated	—
	Metal shell	Phosphor bronze	Tin plated	—

Item	Part	Material	Finish	Remarks
Receptacle (Space-saving)	Insulator	LCP	Color: Black	UL94V-0
	Contacts	Phosphor bronze	Gold plated	—
	Metal cover	Phosphor bronze	Gold plated	—
Plug (Space-saving)	Insulator	LCP	Color: Natural (Beige)	UL94V-0
	Contacts	Phosphor bronze	Gold plated	—
	Metal shell	Phosphor bronze	Gold plated	—

### Ordering information

#### Connector

**DF 36 A J - \* S - 0.4 V**

① ② ③ ④ ⑤ ⑥ ⑦ ⑧

**DF 36 A - \* P - SHL**

① ② ③ ⑤ ⑥ ⑨

① Series name : DF	④ Insulator type J : Receptacles for conductivity tests Blank : Standard or space-saving	⑥ Connector style S : Single-row receptacle P : Single-row plug
② Series No. : 36		
③ Connector style Receptacle/shell A : Standard Blank : Space-saving Plug Blank : Standard	⑤ Number of contacts Standard : 25~45 Space-saving : 25~40 Receptacles for conductivity tests : 25~45	⑦ Contact pitch: 0.4 mm
		⑧ Termination type V : Straight SMT SD : Fine coaxial cable plug

**DF36 Series 0.4 mm Pitch, 1.5 mm Mated Height, Board-to-Fine Coaxial Cable Connectors**

**Receptacles - Standard, with metal cover**

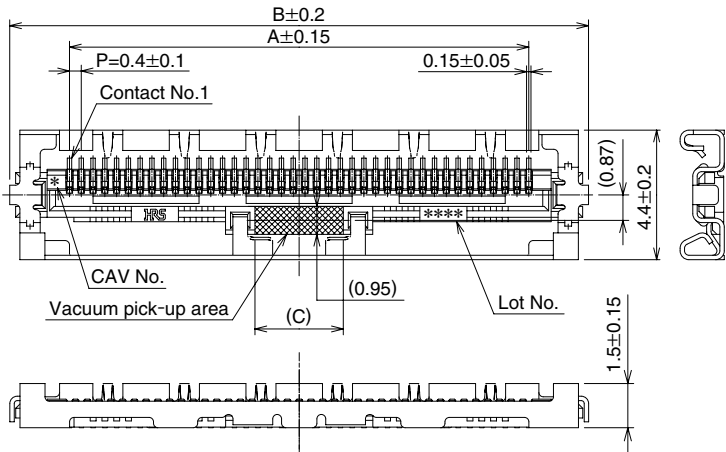

[Specifications number] - \*\*, (\*\*)  
 (51) : Embossed tape packaging  
 (4,000 pieces per reel)

All dimensions: mm

Part Number	CL No.	Number of Contacts	A	B	C	RoHS
DF36A-25S-0.4V(**)	662-4011-4-***	25	9.6	13.66	2.6	YES
DF36A-30S-0.4V(**)	Reserved for product expansion	30	11.6	15.66	3.0	
DF36A-40S-0.4V(**)	662-4003-6-***	40	15.6	19.66	3.0	
DF36A-45S-0.4V(**)	662-4008-0-***	45	17.6	21.66	3.0	

Note 1: Tape and reel packaging (4,000 pieces/reel).  
 Order by number of reels.

**Recommended PCB mounting pattern**

●25 pos.

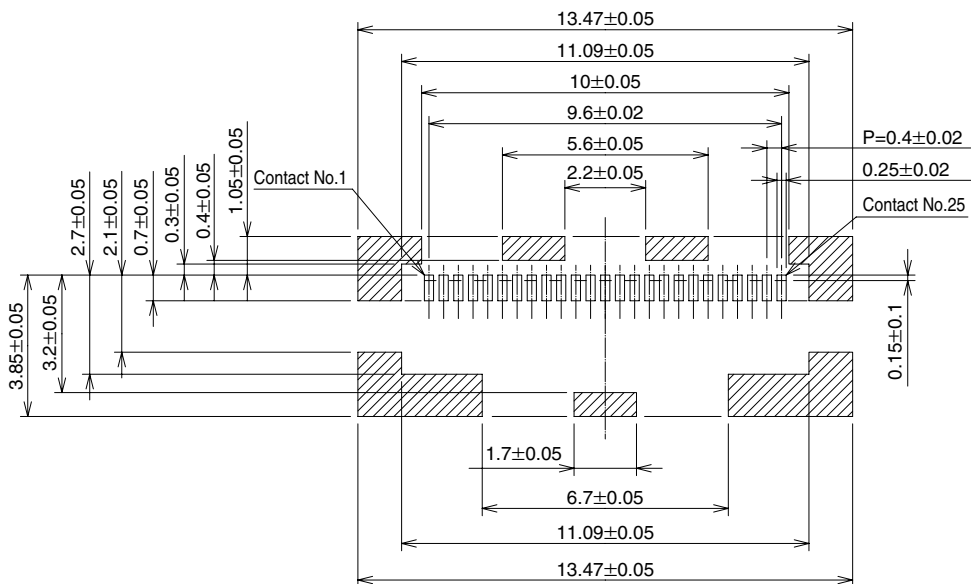

Ground connecting areas

Refer to User Recommendations page (Para. #3) for the recommended metal mask dimensions and open area ratios.

## ◆ Recommended PCB mounting patterns

### ● 30 pos.

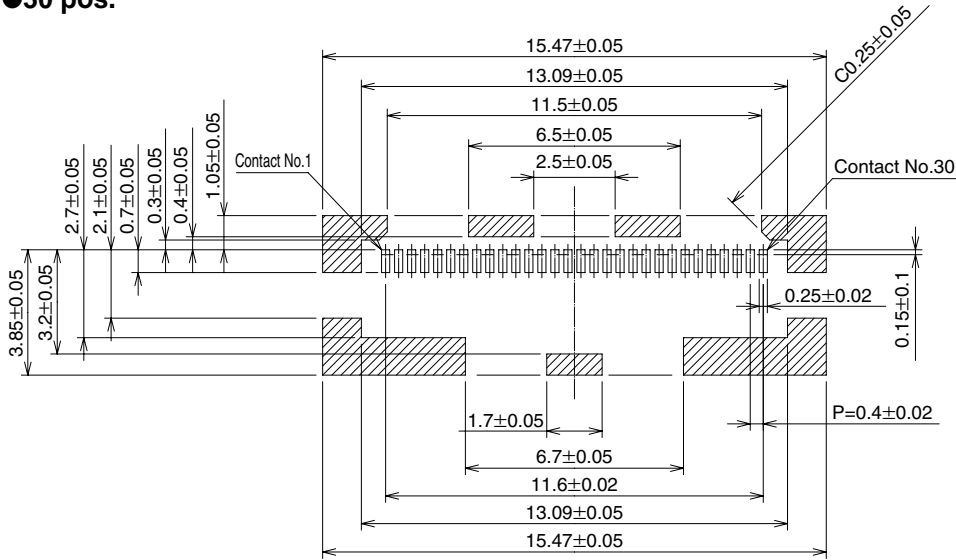

▨ Ground connecting areas

Refer to Usage Recommendations page (Para. #3) for the recommended metal mask dimensions and open area ratios.

### ● 40 pos.

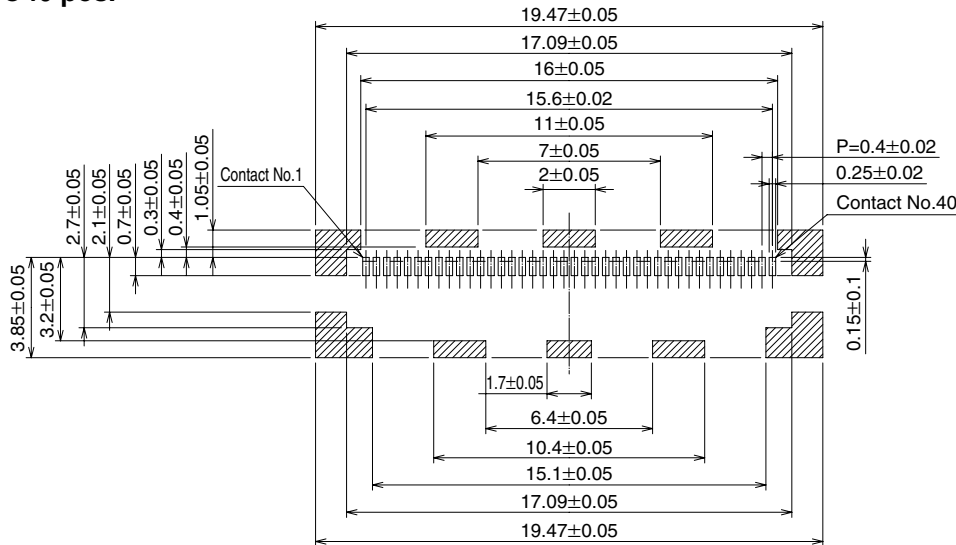

▨ Ground connecting areas

Refer to User Recommendations page (Para. #3) for the recommended metal mask dimensions and open area ratios.

### ● 45 pos.

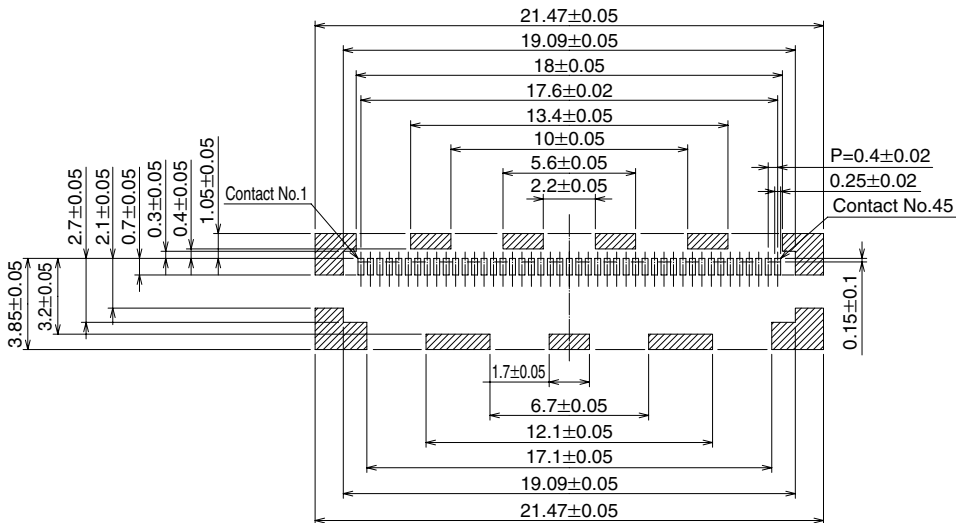

▨ Ground connecting areas

Refer to User Recommendations page (Para. #3) for the recommended metal mask dimensions and open area ratios.

DF36 Series 0.4 mm Pitch, 1.5 mm Mated Height, Board-to-Fine Coaxial Cable Connectors

## Receptacles - Space-saving

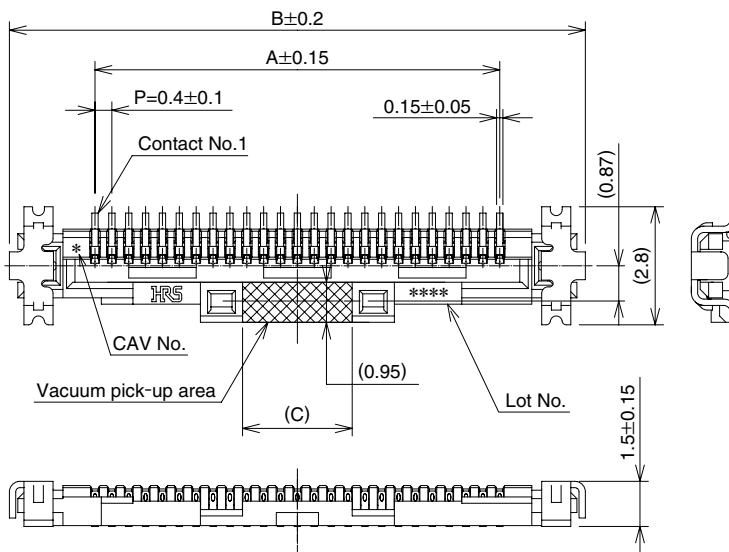

[Specifications number] - \* \*, (\* \*)  
 (51) : Embossed tape packaging  
 (5,000 pieces per reel)

All dimensions: mm

Part Number	CL No.	Number of Contacts	A	B	C	D	RoHS
DF36-25S-0.4V(**)	662-4005-1-***	25	9.6	13.66	2.6	12.28	YES
DF36-30S-0.4V(**)	Reserved for product expansion	30	11.6	15.66	3.0	14.28	
DF36-40S-0.4V(**)	Reserved for product expansion	40	15.6	19.66	3.0	18.28	

Note 1: Tape and reel packaging (5,000 pieces/reel).  
 Order by number of reels.

## Recommended PCB mounting pattern

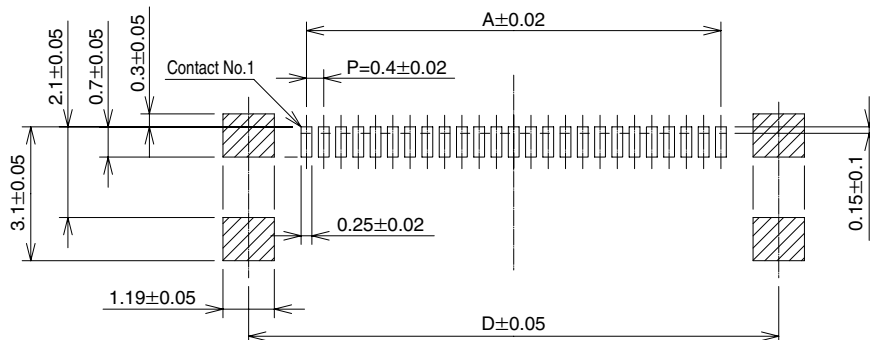

Ground connecting areas

Refer to User Recommendations page (Para. #3) for the recommended metal mask dimensions and open area ratios.

## DF36 Series 0.4 mm Pitch, 1.5 mm Mated Height, Board-to-Fine Coaxial Cable Connectors

### ■ Plug

● Separate metal cover required

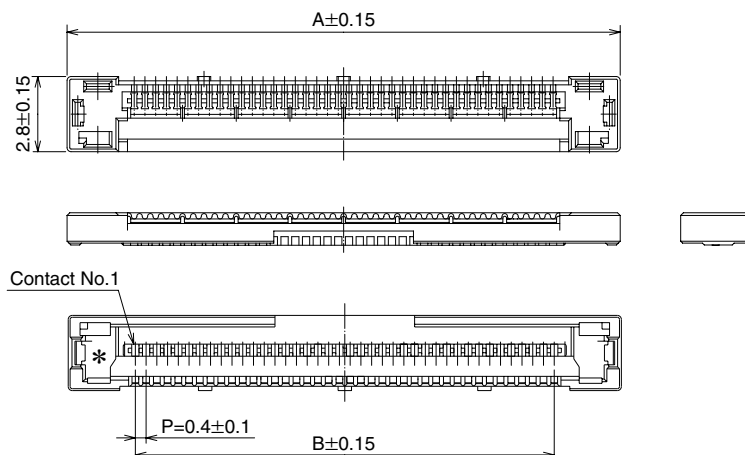

All dimensions: mm

Part Number	CL No.	Number of Contacts	A	B	C	D	RoHS
DF36-25P-0.4SD	662-4006-4	25	14.6	9.6	10.6	11.5	YES
DF36-30P-0.4SD	Reserved for product expansion	30	16.6	11.6	12.6	13.5	
DF36-40P-0.4SD	662-4002-3	40	20.6	15.6	16.6	17.5	
DF36-45P-0.4SD	662-4009-2	45	22.6	17.6	18.6	19.5	

Note 1: Tray packaging (100 pieces/tray).

Order by quantity of trays.

Note 2: The metal cover is required for fine coaxial cable termination.

### ◆ Recommended Fine Coaxial Cable Preparation

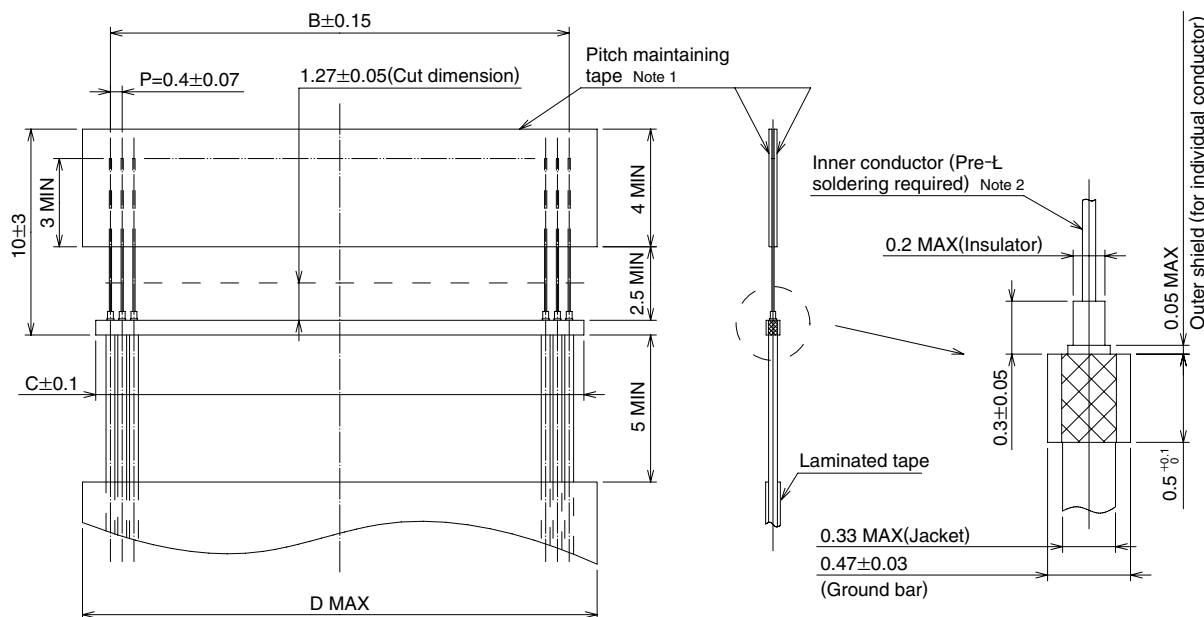

Note 1: The pitch maintaining tape can be left in place during the termination process. Use high quality tape.

Note 2: Contact Hirose for Termination Procedures.

## ■ Metal cover - Required for assembly and termination of the Plug

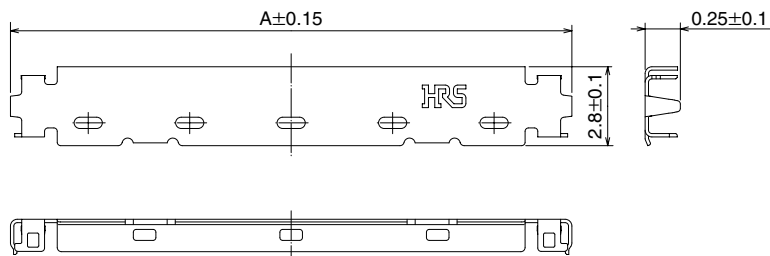

All dimensions: mm

Part Number	CL No.	Receptacle	Plating	Number of Contacts	A	RoHS
DF36A-25P-SHL	662-4007-7	Standard	Tin	25	13.92	YES
DF36-25P-SHL	662-4012-7	Space-saving	Gold			
DF36A-30P-SHL	Reserved for product expansion	Standard	Tin	30	15.92	
DF36-30P-SHL	Reserved for product expansion	Space-saving	Gold			
DF36A-40P-SHL	662-4013-0	Standard	Tin	40	19.92	
DF36-40P-SHL	Reserved for product expansion	Space-saving	Gold			
DF36A-45P-SHL	662-4010-1	Standard	Tin	45	21.92	

Note 1: Tape and reel packaging (10,000 pieces/reel).  
 Order by number of reels.

**DF36 Series 0.4 mm Pitch, 1.5 mm Mated Height, Board-to-Fine Coaxial Cable Connectors**

**◆ Packaging Specification**

**● Embossed Carrier Tape Dimensions – Standard Receptacle**

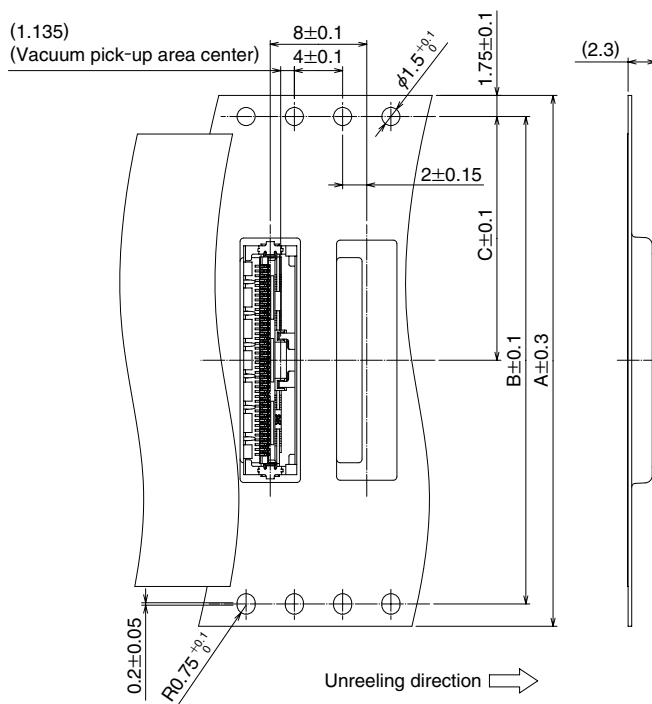

**● Reel Dimensions**

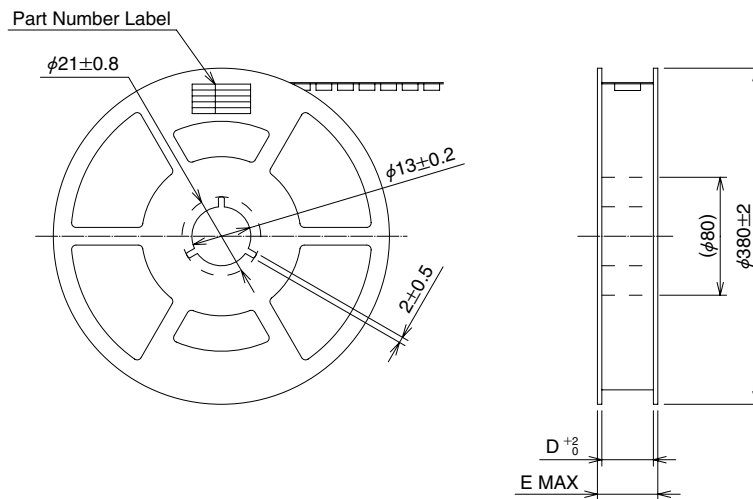

All dimensions: mm

Part Number	CL No.	Number of Contacts	A	B	C	D	E
DF36A-25S-0.4V(51)	662-4011-4-51	25	32	28.4	14.2	32.4	38.4
DF36A-30S-0.4V(51)	Reserved for product expansion	30	32	28.4	14.2	32.4	38.4
DF36A-40S-0.4V(51)	662-4003-6-51	40	44	40.4	20.2	44.4	50.4
DF36A-45S-0.4V(51)	662-4008-0-51	45	44	40.4	20.2	44.4	50.4

Note 1: Tape and reel packaging (4,000 pieces/reel).



**DF36 Series 0.4 mm Pitch, 1.5 mm Mated Height, Board-to-Fine Coaxial Cable Connectors**

**◆ Packaging Specification**

**● Embossed Carrier Tape Dimensions – Space saving Receptacle**

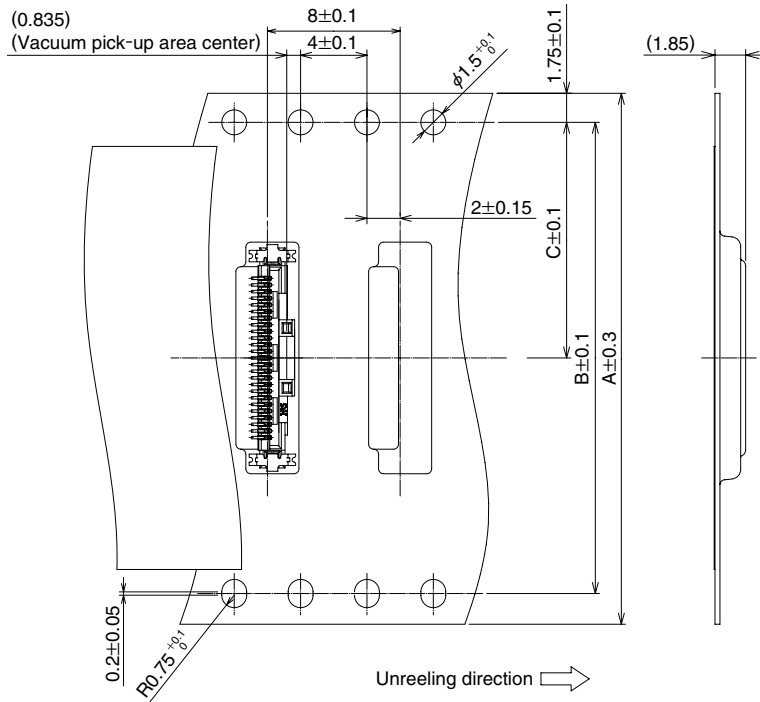

**● Reel Dimensions**

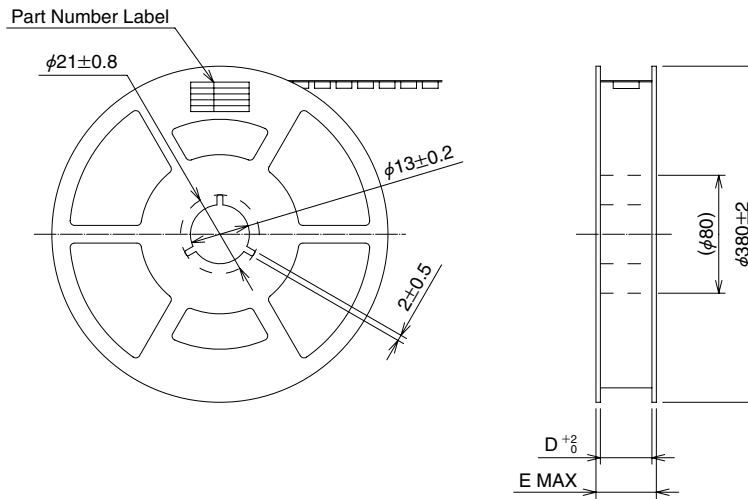

All dimensions: mm

Part Number	CL No.	Number of Contacts	A	B	C	D	E
DF36-25S-0.4V(51)	662-4005-1-51	25	32	28.4	14.2	32.4	38.4
DF36-30S-0.4V(51)	Reserved for product expansion	30	32	28.4	14.2	32.4	38.4
DF36-40S-0.4V(51)	Reserved for product expansion	40	44	40.4	20.2	44.4	50.4

Note 1: Tape and reel packaging (5,000 pieces/reel).



## ◆ Precautions

### Precautions

· Mating / un-mating

#### [ Standard ]

Mate the plug with the receptacle by pressing straight against the entire plug surface. Do NOT mate the plug while holding by the terminated cable.

Use a dedicated extraction tool to un-mate the plug.

Insert the tool under either end of the plug (clearance) and pull straight up as illustrated below.

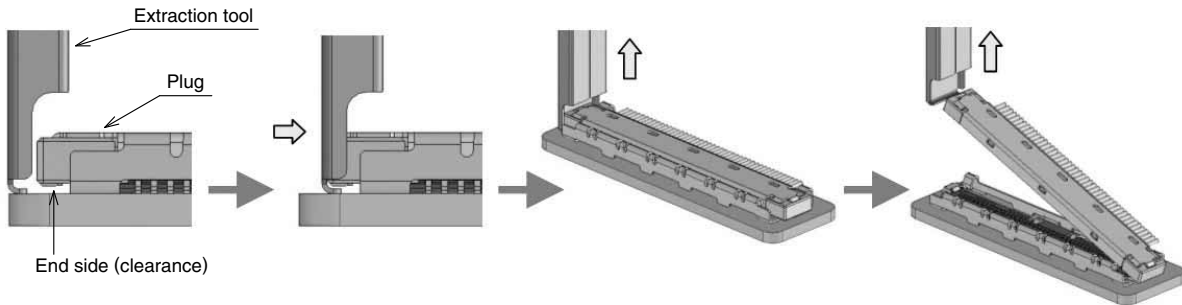

#### [ Space-saving ]

Mate the plug with the receptacle by pressing straight against the entire plug surface, the same as the standard. Use a dedicated extraction tool to un-mate the plug.

Insert the tool under the plug at the front side (clearance) and pull straight up, as illustrated below.

Do NOT mate / un-mate the connectors when receptacle is not mounted on the board.

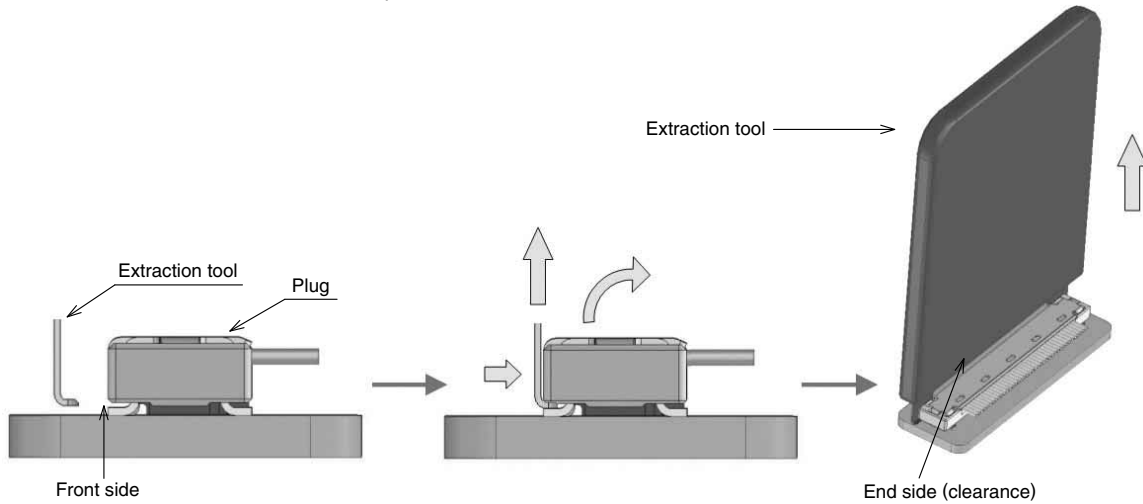

· Different production lots may exhibit different shades of the insulator materials. No affect on form, fit or function of the connectors.