

# SL22-N THRU SL24-N

## List

List..... 1

Package outline..... 2

Features..... 2

Mechanical data..... 2

Maximum ratings ..... 2

Rating and characteristic curves..... 3

Pinning information.....4

Marking..... 4

Suggested solder pad layout..... 4

Packing information..... 5

Reel packing..... 6

Suggested thermal profiles for soldering processes..... 6

High reliability test capabilities.....7



Document ID	Issued Date	RevisedDate	Revision	Page.
DS-121656	2008/02/10	-	A	7

# SL22-N THRU SL24-N

## 1.5A Surface Mount Schottky Barrier Rectifiers - 20V-40V

### Features

- Batch process design, excellent power dissipation offers better reverse leakage current and thermal resistance.
- Low profile surface mounted application in order to optimize board space.
- Very tiny plastic SMD package.
- Low power loss, high efficiency.
- High current capability, very low forward voltage drop.
- High surge capability.
- Guardring for overvoltage protection.
- Ultra high-speed switching.
- Silicon epitaxial planar chip, metal silicon junction.
- Lead-free parts meet environmental standards of MIL-STD-19500 /228

### Mechanical data

- Epoxy : UL94-V0 rated flame retardant
- Case : Molded plastic, SOD-323
- Terminals :Plated terminals, solderable per MIL-STD-750, Method 2026
- Polarity : Indicated by cathode band
- Mounting Position : Any
- Weight : Approximated 0.008 gram

### Package outline

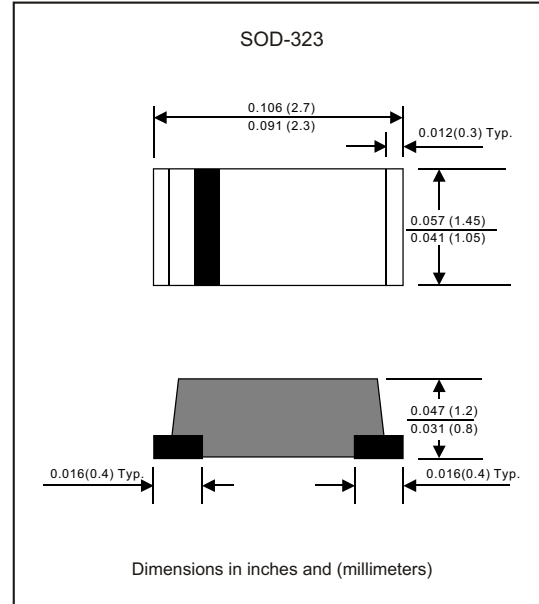

### Maximum ratings (AT $T_A=25^\circ\text{C}$ unless otherwise noted)

PARAMETER	CONDITIONS	Symbol	MIN.	TYP.	MAX.	UNIT
Forward rectified current	See Fig.2	$I_O$			1.5	A
Forward surge current	8.3ms single half-sine-wave superimposed on rate load (JEDEC method)	$I_{FSM}$			30	A
Reverse current	$V_R = 15V$ $T_A = 25^\circ\text{C}$	$I_R$		65	100.0	$\mu\text{A}$
Thermal resistance	Junction to ambient	$R_{BJA}$		80		$^\circ\text{C}/\text{W}$
Diode junction capacitance	$f=1\text{MHz}$ and applied 4V DC reverse voltage	$C_J$		130		$\text{pF}$
Storage temperature		$T_{STG}$	-65		+175	$^\circ\text{C}$
Storage temperature	$I_F = 100\text{mA}$	$V_F$		240	250	mV
	$I_F = 500\text{mA}$			300	350	
	$I_F = 2000\text{mA}$			430	450	

SYMBOLS	$V_{RRM}^{*1}$ (V)	$V_{RMS}^{*2}$ (V)	$V_R^{*3}$ (V)	Operating temperature $T_J$ , ( $^\circ\text{C}$ )
SL22-N	20	14	20	-55 to +125
SL23-N	30	21	30	
SL24-N	40	28	40	

\*1 Repetitive peak reverse voltage

\*2 RMS voltage

\*3 Continuous reverse voltage

## Rating and characteristic curves (SL22-N THRU SL24-N)

FIG.1-TYPICAL FORWARD CHARACTERISTICS

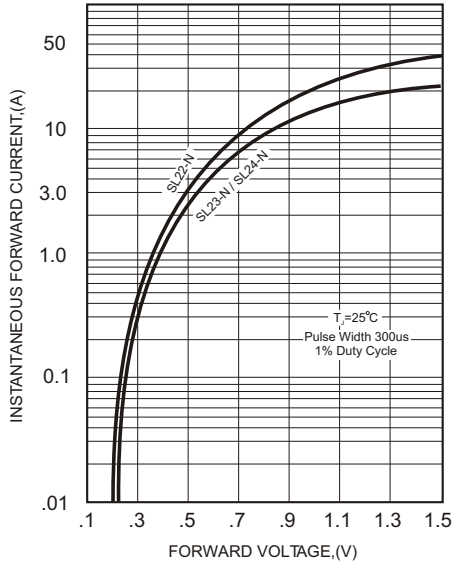

FIG.2-TYPICAL FORWARD CURRENT DERATING CURVE

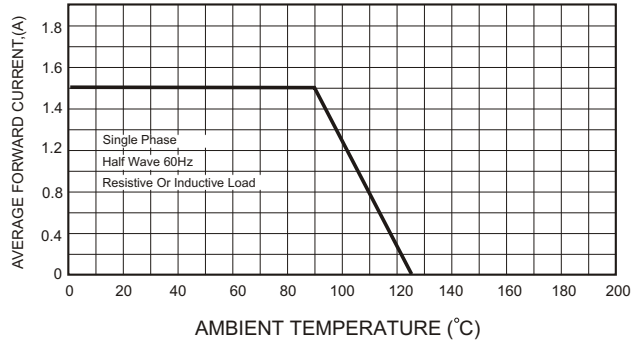

FIG.4-MAXIMUM NON-REPETITIVE FORWARD SURGE CURRENT

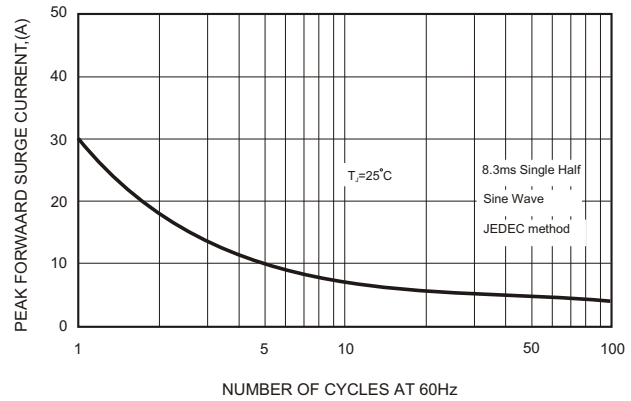

FIG.3 - TYPICAL REVERSE CHARACTERISTICS

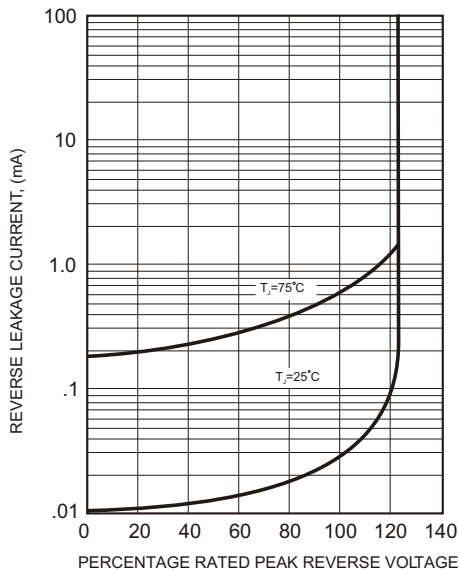
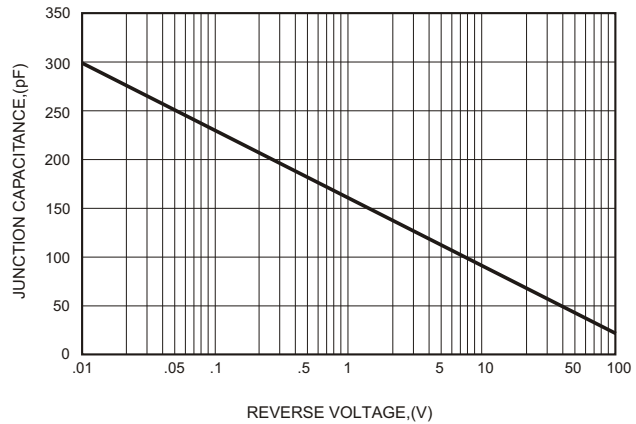



FIG.5-TYPICAL JUNCTION CAPACITANCE



# SL22-N THRU SL24-N

## Pinning information

Pin	Simplified outline	Symbol
Pin1 cathode Pin2 anode		

## Marking

Type number	Marking code
SL22-N	L2
SL23-N	L3
SL24-N	L4

## Suggested solder pad layout

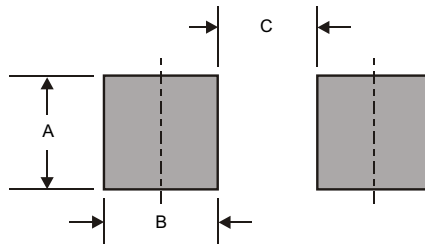

Dimensions in inches and (millimeters)

PACKAGE	A	B	C
SOD-323	0.059 (1.50)	0.039 (1.00)	0.051 (1.30)

# SL22-N THRU SL24-N

## Packing information

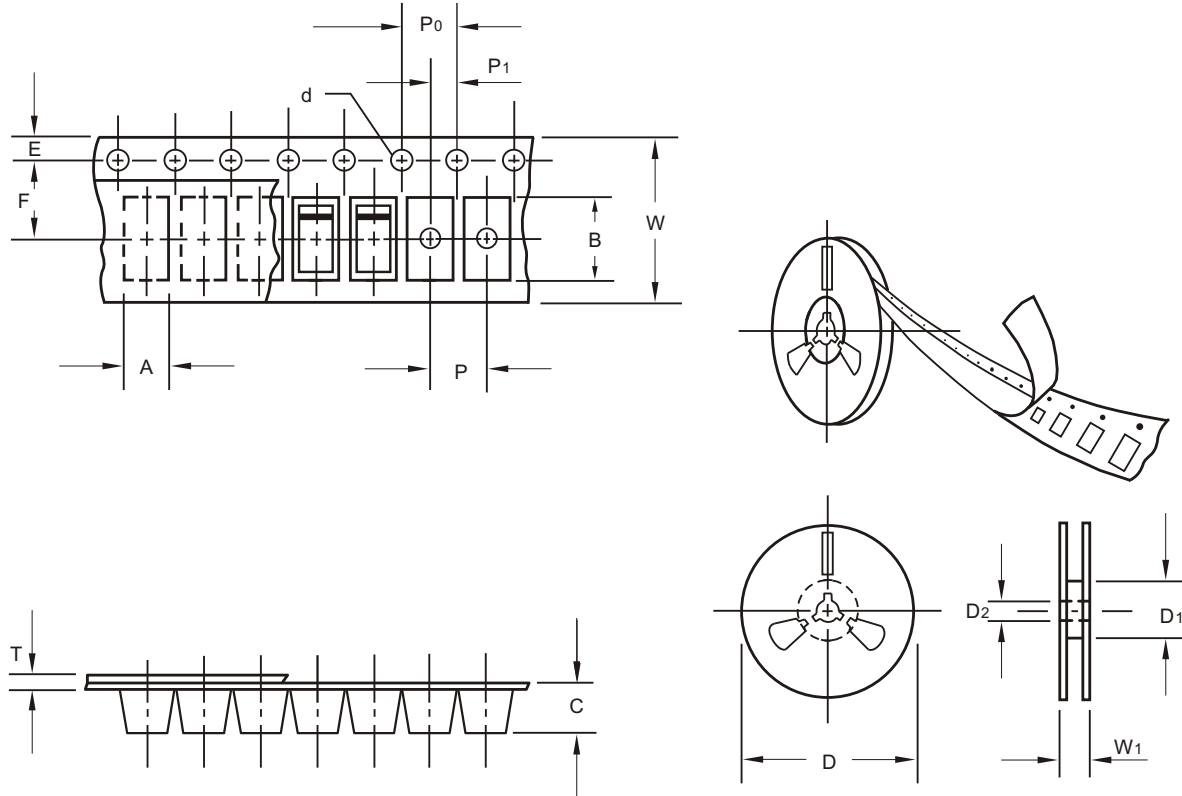

unit:mm

Item	Symbol	Tolerance	SOD-323
Carrier width	A	0.1	1.47
Carrier length	B	0.1	2.95
Carrier depth	C	0.1	1.15
Sprocket hole	d	0.1	1.50
13" Reel outside diameter	D	2.0	-
13" Reel inner diameter	D1	min	-
7" Reel outside diameter	D	2.0	178.00
7" Reel inner diameter	D1	min	62.00
Feed hole diameter	D2	0.5	13.00
Sprocket hole position	E	0.1	1.75
Punch hole position	F	0.1	3.50
Punch hole pitch	P	0.1	4.00
Sprocket hole pitch	P0	0.1	4.00
Embossment center	P1	0.1	2.00
Overall tape thickness	T	0.1	0.23
Tape width	W	0.3	8.00
Reel width	W1	1.0	11.40

Note: Devices are packed in accordance with EIA standard RS-481-A and specifications listed above.

# SL22-N THRU SL24-N

## Reel packing

PACKAGE	REEL SIZE	REEL (pcs)	COMPONENT SPACING (m/m)	BOX (pcs)	INNER BOX (m/m)	REEL DIA, (m/m)	CARTON SIZE (m/m)	CARTON (pcs)	APPROX. GROSS WEIGHT (kg)
SOD-323	7"	3000	4.0	12,000	185*185*51	178	430*190*220	96,000	4.1

## Suggested thermal profiles for soldering processes

- 1.Storage environment: Temperature=10°C~35°C Humidity=65%±15%
- 2.Reflow soldering of surface-mount devices

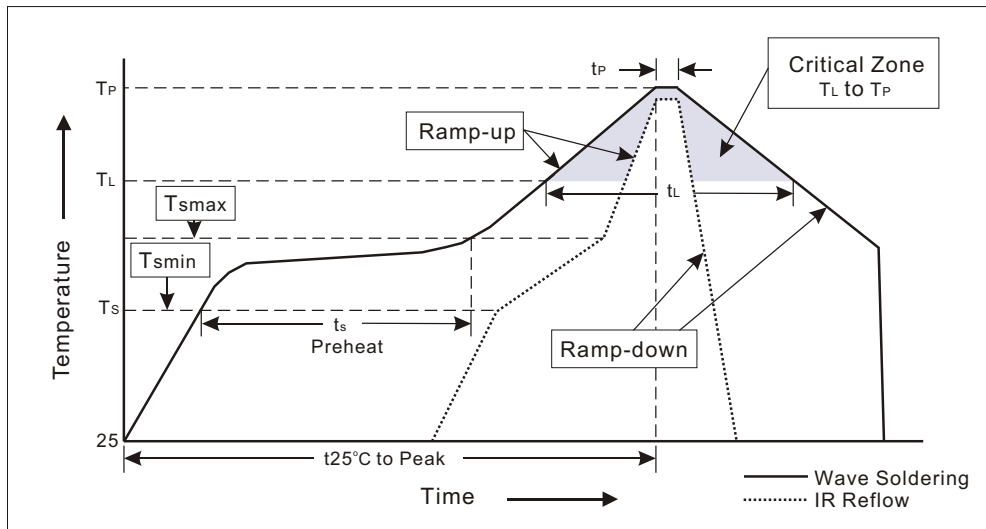

### 3.Flow (wave)soldering (solder dipping)

Profile Feature	Soldering Condition
Average ramp-up rate( $T_L$ to $T_P$ )	<3°C/sec
Preheat -Temperature Min( $T_{smin}$ ) -Temperature Max( $T_{smax}$ ) -Time(min to max)( $t_s$ )	100°C 150°C 60~120sec
$T_{smax}$ to $T_L$ -Ramp-upRate	<3°C/sec
Time maintained above: -Temperature( $T_L$ ) -Time( $t_L$ )	183°C 60~150sec
Peak Temperature( $T_P$ )	255°C-0/+5°C
Time within 5°C of actual Peak Temperature( $t_p$ )	10~30sec
Ramp-down Rate	<6°C/sec
Time 25°C to Peak Temperature	<6minutes

# SL22-N THRU SL24-N

## High reliability test capabilities

Item Test	Conditions	Reference
1. Solder Resistance	at 260±5°C for 10±2sec. immerse body into solder 1/16"±1/32"	MIL-STD-750D METHOD-2031
2. Solderability	at 245±5°C for 5 sec.	MIL-STD-202F METHOD-208
3. High Temperature Reverse Bias	V <sub>R</sub> =80% rate at T <sub>A</sub> =125°C for 168 hrs.	MIL-STD-750D METHOD-1026
4. Forward Operation Life	Rated average rectifier current at T=25°C for 500hrs.	MIL-STD-750D METHOD-1027
5. Intermittent Operation Life	T <sub>A</sub> = 25°C, I <sub>F</sub> = I <sub>O</sub> On state: power on for 5 min. off state: power off for 5 min. on and off for 500 cycles.	MIL-STD-750D METHOD-1036
6. Pressure Cooker	15P <sub>sig</sub> at T <sub>A</sub> =121°C for 4 hrs.	
7. Temperature Cycling	-55°C to +125°C dwelled for 30 min. and transferred for 5min. total 10 cycles.	MIL-STD-750D METHOD-1051
8. Thermal Shock	0°C for 5 min. rise to 100°C for 5 min. total 10 cycles.	MIL-STD-750D METHOD-1056
9. Forward Surge	8.3ms single halfsine-wave superimposed on rated load, one surge.	MIL-STD-750D METHOD-4066-2
10. Humidity	at T <sub>A</sub> =65°C, RH=98% for 1000hrs.	MIL-STD-750D METHOD-1038
11. High Temperature Storage Life	at 175°C for 1000 hrs.	MIL-STD-750D METHOD-1031
12. Solvent Resistance	Dip into Freon at 25°C for 1 min.	MIL-STD-202F METHOD-215