

GENERAL INFORMATION

AVX SL Series

Conformally Coated Radial Ledged MLC

Temperature Coefficients: C0G (NP0), X7R, Z5U

200, 100, 50 Volts (300V, 400V & 500V also available)

Case Material: Epoxy

Lead Material: Solderable Sn/Pb

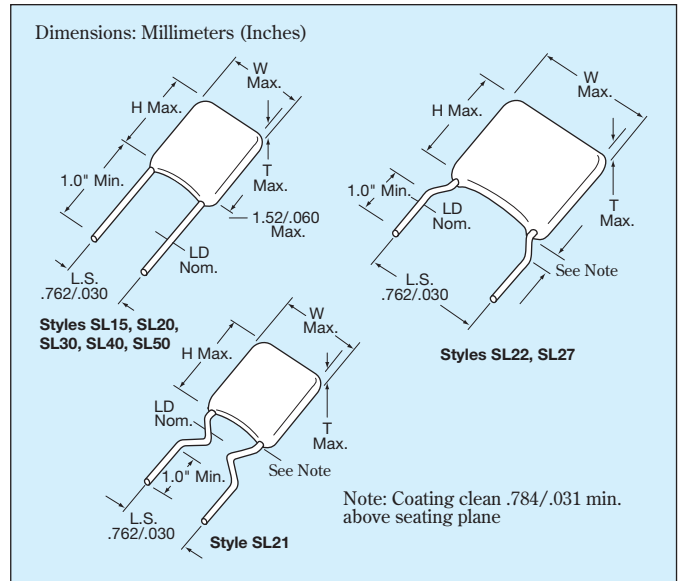

HOW TO ORDER

SL21	5	E	104	M	A	B
AVX Style	Voltage	Temperature Coefficient	Capacitance	Capacitance Tolerance	Failure Rate	Leads
SL15 SL20 SL21 SL22 SL27 SL30 SL40 SL50	5 = 50V 1 = 100V 2 = 200V 9 = 300V 8 = 400V 7 = 500V	A = C0G (NP0) C = X7R E = Z5U	First two digits are the significant figures of capacitance. Third digit indicates the additional number of zeros. For example, order 100,000 pF as 104. (For values below 10pF use "R" in place of decimal point, e.g., 1R4 = 1.4pF.)	C0G (NP0): C = ±.25pF D = ±.5pF F = ±1% (>50pF only) G = ±2% (>25pF only) J = ±5% K = ±10%	X7R: J = ±5% K = ±10% M = ±20% Z5U: M = ±20% Z = +80% -20%	A = Not Applicable B = Sn/Pb

MARKING

FRONT

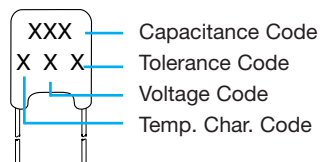

BACK

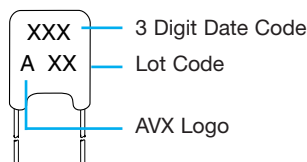

PACKAGING REQUIREMENTS

	Quantity per Bag
SL15, 20, 21, 22, 27, 30	1000 Pieces
SL40, 50	500 Pieces

Note: SL15, SL20, SL21, SL30, and SL40 available on tape and reel per EIA specifications RS-468. See Pages 33 and 34.

Radial Leads/SkyCap®/SL Series



C0G (NP0) Dielectric

SIZE AND CAPACITANCE SPECIFICATIONS

EIA Characteristic		Dimensions: Millimeters (Inches)																										
AVX Style		SL15			SL20			SL21			SL22			SL27			SL30		SL40		SL50							
AVX "Insertable"		SL07			SL29			SL59			N/A			N/A			SL65		SL75		N/A							
Width (W)		3.81			5.08			5.08			5.08			5.08			6.604			7.62			10.16			12.70		
Height (H)		3.81			5.08			5.08			5.08			5.08			6.35			7.62			10.16			12.70		
Thickness (T)		2.54			3.175			3.175			3.175			3.175			4.06			3.81			3.81			5.08		
Lead Spacing (L.S.)		2.54			2.54			5.08			6.35			7.62			5.08			5.08			5.08			10.16		
Lead Diameter (L.D.)		.508			.508			.508			.508			.508			.508			.508			.508			.635		
Cap. in.* Industry Preferred pF	Values in Blue	WVDC			WVDC			WVDC			WVDC			WVDC			WVDC		WVDC		WVDC							
		200	100	50	200	100	50	200	100	50	200	100	50	200	100	50	200	100	50	100	50	100	50	100	50	100	50	
1.0-9.9	SL151A1R0DAB																											
10	SL151A100KAB																											
15	SL.....A150KAB																											
22	SL.....A220KAB																											
33	SL.....A330KAB																											
39	SL.....A390KAB																											
47	SL.....A470KAB																											
68	SL.....A680KAB																											
100	SL151A101KAB																											
150	SL.....A151KAB																											
220	SL.....A221KAB																											
330	SL.....A331KAB																											
390	SL.....A391KAB																											
470	SL.....A471KAB																											
680	SL.....A681KAB																											
1000	SL211A102KAB																											
1500	SL.....A152KAB																											
2200	SL.....A222KAB																											
3900	SL.....A392KAB																											
4700	SL.....A472KAB																											
6800	SL.....A682KAB																											
8200	SL.....A822KAB																											
10,000	SL305A103KAB																											
15,000	SL.....A153KAB																											
22,000	SL.....A223KAB																											
33,000	SL.....A333KAB																											
39,000	SL.....A393KAB																											
47,000	SL.....A473KAB																											
68,000	SL.....A683KAB																											
100,000	SL.....A104KAB																											

For other styles, voltages, tolerances and lead lengths see Part No. Codes or contact factory.

*Other capacitance values available upon special request.

- = Industry preferred values
- = SL20 only

NOTE: Capacitance Ranges available for SL12 same as SL15
 SL62 same as SL21
 SL64 same as SL30
 SL89 same as SL21



Radial Leads/SkyCap®/SL Series







X7R Dielectric

SIZE AND CAPACITANCE SPECIFICATIONS

EIA Characteristic		Dimensions: Millimeters (Inches)																					
AVX Style		SL15			SL20			SL21			SL22		SL27		SL30		SL40			SL50			
AVX "Insertable"		SL07			SL29			SL59			N/A		N/A		SL65		SL75			N/A			
Width (W)		3.81 (.150)	5.08 (.200)	5.08 (.200)	5.08 (.200)	5.08 (.200)	5.08 (.200)	6.604 (.260)	7.62 (.300)	10.16 (.400)	12.70 (.500)												
Height (H)		3.81 (.150)	5.08 (.200)	5.08 (.200)	5.08 (.200)	5.08 (.200)	6.35 (.250)	7.62 (.300)	10.16 (.400)	12.70 (.500)													
Thickness (T)		2.54 (.100)	3.175 (.125)	3.175 (.125)	3.175 (.125)	4.06 (.160)	3.81 (.150)	3.81 (.150)	5.08 (.200)	10.16 (.400)													
Lead Spacing (L.S.)		2.54 (.100)	2.54 (.100)	5.08 (.200)	6.35 (.250)	7.62 (.300)	5.08 (.200)	5.08 (.200)	10.16 (.400)														
Lead Diameter (L.D.)		.508 (.020)	.508 (.020)	.508 (.020)	.508 (.020)	.508 (.020)	.508 (.020)	.508 (.020)	.508 (.020)	.635 (.025)													
Cap. in.* Industry Preferred Values in Blue		WVDC			WVDC			WVDC		WVDC		WVDC		WVDC		WVDC			WVDC				
		200	100	50	200	100	50	200	100	50	100	50	100	50	200	100	50	200	100	50	200	100	50
470	SL.....C471KAB																						
1000	SL155C102KAB																						
1500	SL.....C152KAB																						
2200	SL.....C222KAB																						
3300	SL.....C332KAB																						
4700	SL.....C472KAB																						
6800	SL.....C682KAB																						
10,000	SL215C103KAB																						
15,000	SL.....C153KAB																						
22,000	SL.....C223KAB																						
33,000	SL.....C333KAB																						
47,000	SL.....C473KAB																						
68,000	SL.....C683KAB																						
100,000	SL215C104KAB																						
150,000	SL.....C154KAB																						
220,000	SL215C224KAB																						
330,000	SL.....C334KAB																						
390,000	SL.....C394KAB																						
470,000	SL305C474KAB																						
1.0 µF	SL305C105KAB																						
2.2 µF	SL405C225KAB																						
2.7 µF	SL505C275KAB																						
4.7 µF	SL505C475KAB																						

For other styles, voltages, tolerances and lead lengths see Part No. Codes or contact factory.

*Other capacitance values available upon special request.

-  = Industry preferred values
-  = SL20 only
-  = Extended range
-  = Extended range, SL20 only
-  = Extended range with 0.150" thickness maximum

NOTE: Capacitance Ranges available for SL12 same as SL15
 SL62 same as SL21
 SL64 same as SL30
 SL89 same as SL21



Radial Leads/SkyCap®/SL Series



Z5U Dielectric

SIZE AND CAPACITANCE SPECIFICATIONS

EIA Characteristic

Dimensions: Millimeters (Inches)

AVX Style	SL15	SL20	SL21	SL22	SL27	SL30	SL40	SL50
AVX "Insertable"	SL07	SL29	SL59	N/A	N/A	SL65	SL75	N/A
Width (W)	3.81 (.150)	5.08 (.200)	5.08 (.200)	5.08 (.200)	6.604 (.260)	7.62 (.300)	10.16 (.400)	12.70 (.500)
Height (H)	3.81 (.150)	5.08 (.200)	5.08 (.200)	5.08 (.200)	6.35 (.250)	7.62 (.300)	10.16 (.400)	12.70 (.500)
Thickness (T)	2.54 (.100)	3.175 (.125)	3.175 (.125)	3.175 (.125)	4.06 (.160)	3.81 (.150)	3.81 (.150)	5.08 (.200)
Lead Spacing (L.S.)	2.54 (.100)	2.54 (.100)	5.08 (.200)	6.35 (.250)	7.62 (.300)	5.08 (.200)	5.08 (.200)	10.16 (.400)
Lead Diameter (L.D.)	.508 (.020)	.508 (.020)	.508 (.020)	.508 (.020)	.508 (.020)	.508 (.020)	.508 (.020)	.635 (.025)
Cap. in.* Industry Preferred Values in Blue	WVDC 100 50	WVDC 100 50	WVDC 100 50	WVDC 100 50	WVDC 100 50	WVDC 100 50	WVDC 100 50	WVDC 100 50
10,000 47,000 100,000	SL155E103ZAB SL.....E473ZAB SL215E104ZAB							
150,000 220,000 330,000	SL.....E154ZAB SL215E224ZAB SL215E334ZAB							
470,000 680,000	SL215E474ZAB SL.....E684ZAB							
1.0 µF 1.5 µF 2.2 µF	SL.....105ZAB SL30E155ZAB SL30E225ZAB							
3.3 µF 4.7 µF	SL30E335ZAB SL30E475ZAB							

For other styles, voltages, tolerances and lead lengths see Part No. Codes or contact factory.

*Other capacitance values available upon special request.

- = Industry preferred values
- = SL20 only

AVX 500 VOLT SKYCAPS**

STYLE*	MAXIMUM CAPACITANCE VALUE	
	COG (NP0)	X7R
SL29	900 pF	.015 µF
SL20	1800 pF	.033 µF
SL28 SL59	900 pF	.015 µF
SL13 SL21	1800 pF	.033 µF
SL30 SL61 SL65	7200 pF	.12 µF
SL40 SL75	.015 µF	.27 µF
SL22	1800 pF	.033 µF
SL27	1800 pF	.033 µF
SL76	.015 µF	.27 µF
SL50	.036 µF	.59 µF

*Consult pages 27 and 28 for style sizes.

**Voltage rating based on DWV of 150% of rated voltage.



Configurations by Lead Spacing

LEAD SPACING .100 ±.030				Dimensions: Inches (Millimeters)			
<p>AR07/SR07* (T=.100)</p>	<p>AR14/SR14 (T=.100)</p>	<p>AR15/SR15* (T=.100)</p>	<p>AR20/SR20* (T=.125)</p>	<p>AR29/SR29* (T=.125)</p>	<p>AR62/SR62* (T=.125)</p>	<p>SR62-LP* (T=.100)</p>	

LEAD SPACING .200 ±.030					Dimensions: Inches (Millimeters)									
<p>AR12/SR12* (T=.100)</p>	<p>SR13* (T=.125)</p>	<p>AR21/SR21* (T=.125)</p>	<p>SR21-85* (T=.125)</p>	<p>SR28* (T=.125)</p>	<p>AR30/SR30* (T=.150)</p>	<p>SR30-LP* (T=.150)</p>	<p>AR32/SR32* (T=.150)</p>	<p>AR40/SR40* (T=.150)</p>	<p>AR59/SR59* (T=.125)</p>	<p>SR61 (T=.150)</p>	<p>SR63* (T=.150)</p>	<p>SR64* (T=.150)</p>	<p>SR64-LP* (T=.150)</p>	<p>AR65/SR65* (T=.150)</p>

*SL style available in all SR configurations.

Configurations by Lead Spacing

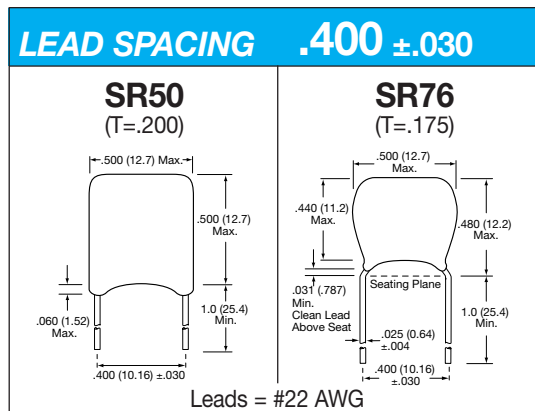
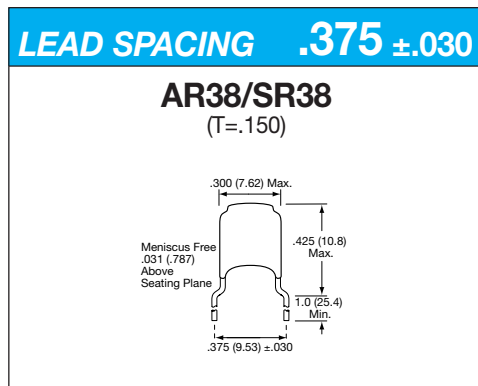
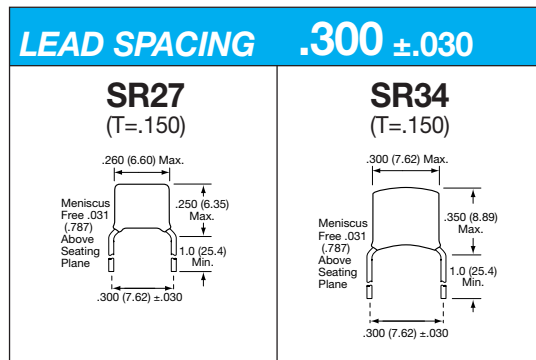
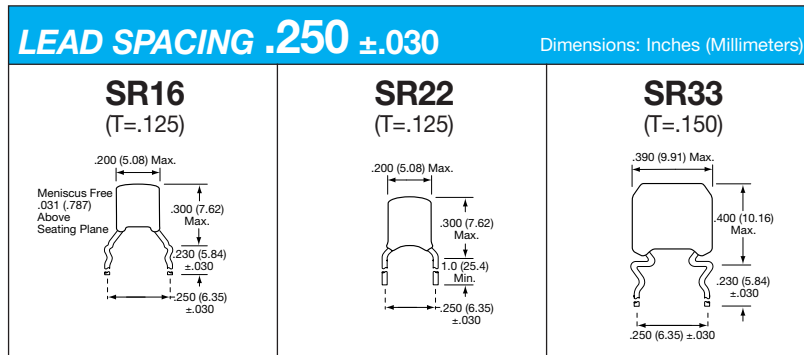
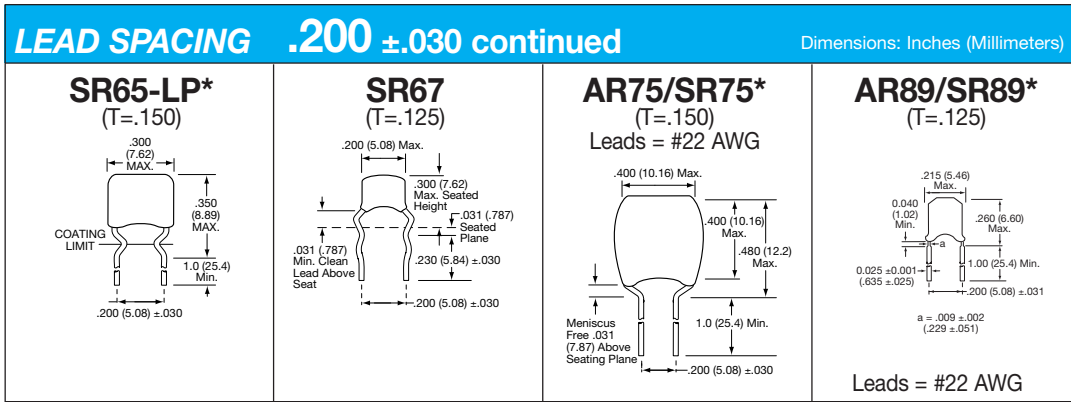

- NOTES:**
1. All leads are #24 AWG unless otherwise noted.
 2. Available in tape and reel packaging(*).
 3. Other styles are also available, contact factory.
 4. (T = XXX) under type designation is maximum thickness in inches.

*SL style available in all SR configurations.

Radial Leads/Packaging

Tape and Reel



GENERAL INFORMATION

1. Standard reel diameter is 355 millimeters (14 inches) maximum.
2. Reeling standard (#1 or #2) should be specified when ordering.

HOW TO ORDER

To specify tape and reel packaging, add TR1, TR2 or TRX to the end of the AVX 12 digit part number.

Examples:

SR215C104KARTR1
SR305E105MARTR2
SR215C103JARTRX

THE INSERTABLES

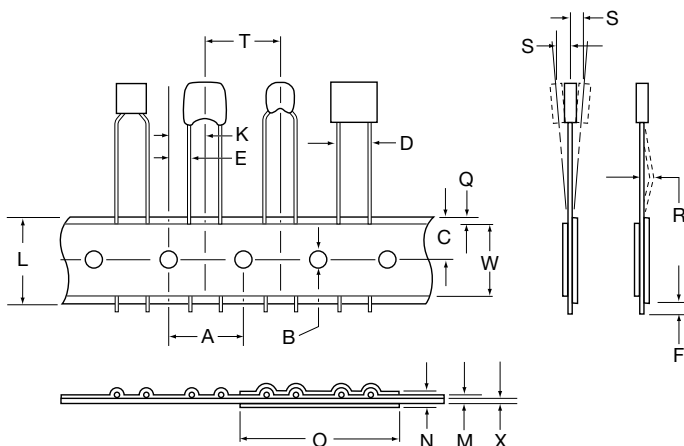
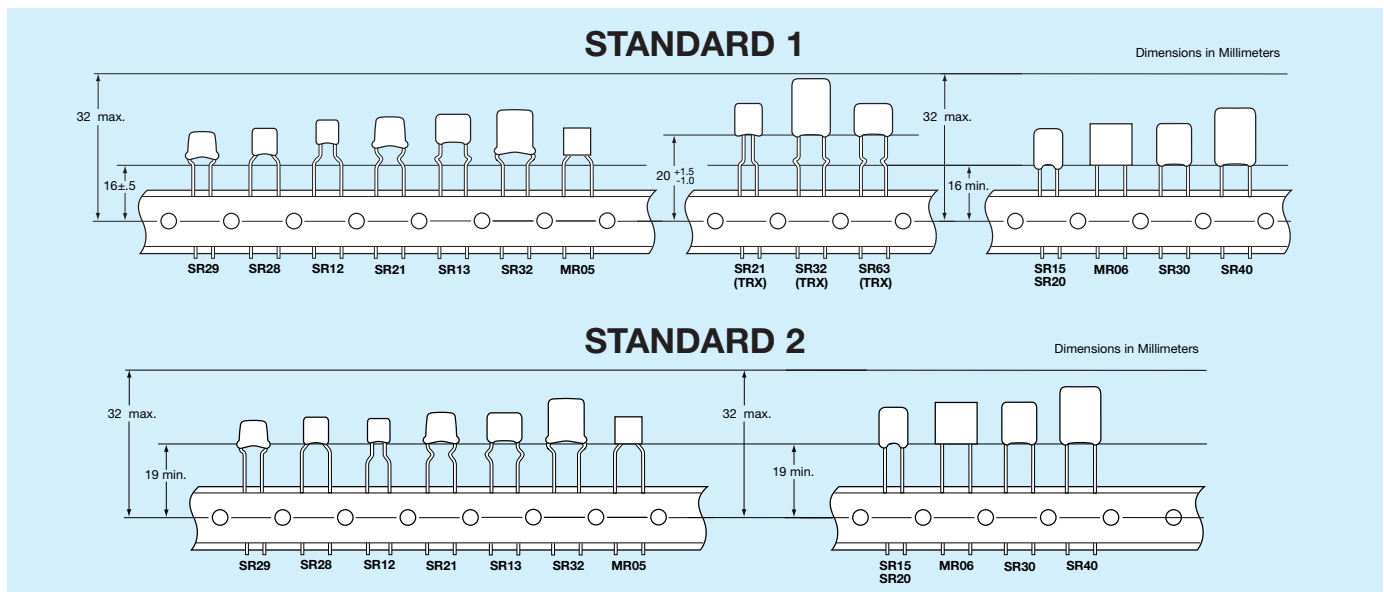
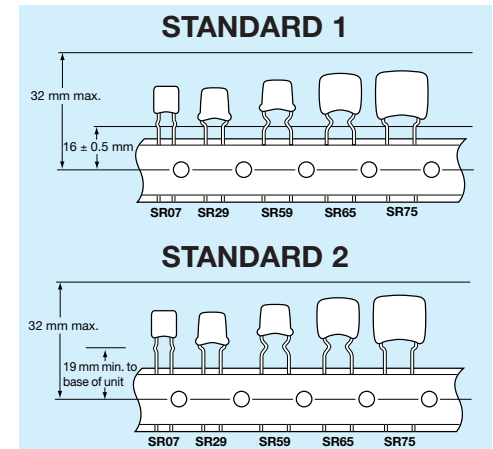

DESCRIPTION

DIMENSIONS (MM)

A. Feed Hole Pitch	12.70 ± .20
B. Feed Hole Diameter	3.99 ± .20
C. Feed Hole Location	9.02 ± .51
D. Component Lead Spacing	5.00 ^{+0.79} _{-.20} or 2.54 ^{+0.79} _{-.20}
E. Component Lead Location	3.81 ± .51 or 5.00 ± .51 for 2.54 lead spacing 2.00 maximum
F. Component Lead Protrusion (edge of carrier to cut end of lead)	2.00 maximum
K. Component Body Location	6.35 ± .41
L. Carrier Tape Width	18.01 ^{+1.02} _{-.51}
M. Carrier Tape Assembly Thickness	.71 ± .20
N. Carrier Tape Spliced Thickness	1.42 maximum
O. Carrier Tape Spliced Length	50.80 - 88.90
Q. Adhesive Tape Border	3.00 maximum
R. Component Bent Leads (either direction)	.79 maximum
S. Component Misalignment	.99 maximum
T. Component Pitch	12.70 ± .99
W. Adhesive Tape Width	5.00 minimum
X. Carrier Tape Thickness	.51 ± .10
Y. Cumulative Pitch over 20 Pitches	254 ± 2.00



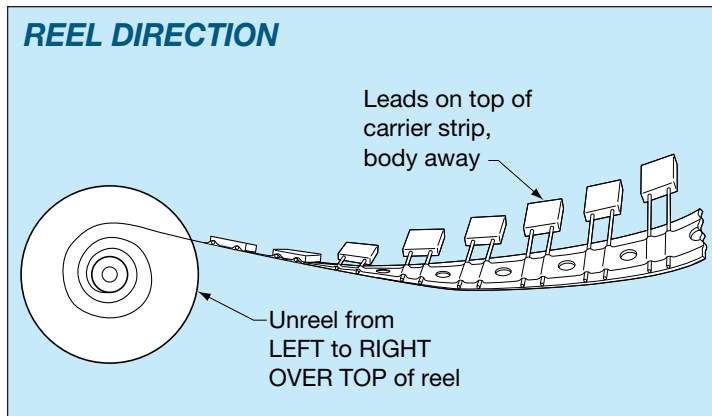

QUANTITY PER REEL SR/AR	
PART	PCS
SR15, 07, 12	3500
SR20, 21, 23, 28 13, 29, 59, 62, 89	3000
SR30, 32, 40, 63, 64 65, 75	2000
MR05, 06	2500

*SL style available in all SR configurations.

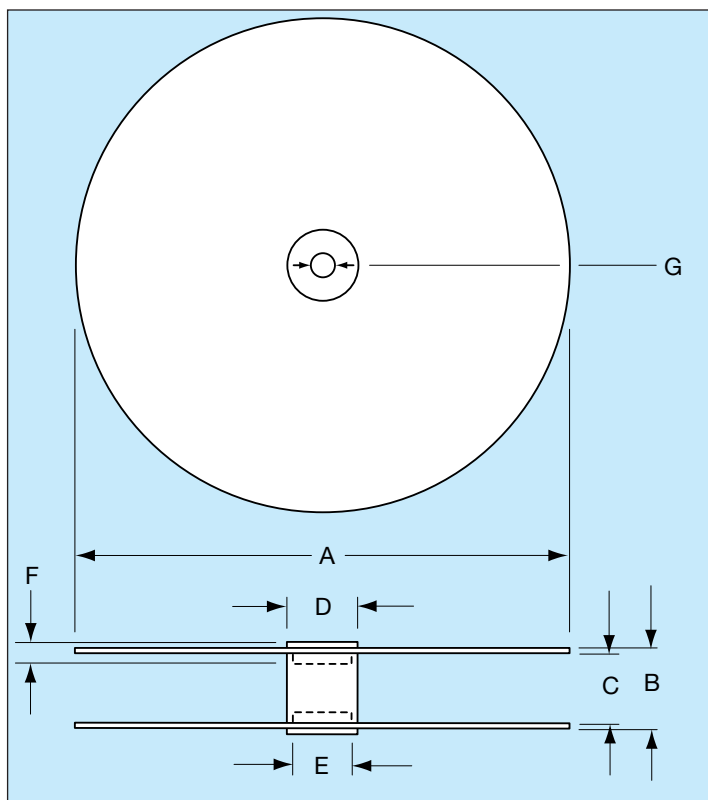

DESCRIPTION	DIMENSIONS (MM)
A – Reel Diameter	304.80 - 355
B – Reel Outside Width	50.80 maximum
C – Reel Inside Width	38.10 - 46.02
D – Core Diameter (O.D.)	102.01 maximum
E – Hub Recess Diameter	86.36 maximum
F – Hub Recess Depth	9.50 minimum
G – Arbor Hole Diameter	25.40 - 30.48

CONVERSION TABLE									
MM	IN	MM	IN	MM	IN	MM	IN	MM	IN
.10	.004	1.52	.060	5.00	.197	9.91	.390	32.00	1.260
.20	.007	2.00	.079	5.08	.200	10.03	.395	38.10	1.500
.38	.015	2.54	.100	6.22	.245	10.16	.400	46.02	1.812
.41	.016	3.00	.118	6.35	.250	11.68	.460	50.80	2.000
.51	.020	3.18	.125	6.60	.260	12.50	.492	86.36	3.400
.71	.028	3.48	.137	6.99	.275	12.70	.500	88.90	3.500
.79	.031	3.81	.150	7.62	.300	16.00	.630	102.01	4.016
.99	.039	3.99	.157	8.89	.350	18.01	.709	254.00	10.000
1.02	.040	4.45	.175	9.02	.355	25.40	1.000	304.80	12.000
1.42	.056	4.98	.196	9.50	.374	30.48	1.200	355.00	14.000