

OVERVIEW

The SM5009 series are crystal oscillator module ICs that incorporate low crystal current type oscillating circuit to limit oscillator-stage current, so that they can reduce crystal current lower than the existing products. Since the oscillating circuit has oscillator capacitors with excellent frequency response and feedback resistor built-in, just connecting crystal realizes stable fundamental oscillation responding up to 40MHz. The SM5009 series are ideal for SMD type crystal oscillator using a strip-shaped crystal blank.

FEATURES

- Low crystal current oscillator
- Up to 40MHz operating frequency range (fundamental oscillation)
- Operating supply voltage range
 - 3V operation: 2.7 to 3.6V
 - 5V operation: 4.5 to 5.5V
- -40 to 85°C operating temperature range
- Oscillation capacitors C_G , C_D built-in
- Inverter amplifier feedback resistor built-in
- Standby function
 - Oscillator stops (AL series), high impedance in standby mode
- Low standby current
- Power-saving pull-up resistor built-in (AL series)
- Frequency divider built-in (f_O , $f_O/2$, $f_O/4$, $f_O/8$, $f_O/16$, $f_O/32$ determined by internal connection)
- Output drive capability
 - AL×, AN×, AK×, CN×: 16mA ($V_{DD} = 4.5V$)
 - AH×: 4mA ($V_{DD} = 4.5V$)
- Output load: $C_L = 50pF$ max.
- Output duty level
 - CMOS level (1/2 VDD): AL×, AN×, AH×, CN×
 - TTL level (1.4V): AK×
- Molybdenum-gate CMOS process
- 8-pin SOP (SM5009×××S)
- Chip form (CF5009×××)

SERIES CONFIGURATION

Version ¹	3V operation		5V operation		Output duty level	Output frequency	INHN Input level	Standby mode	
	Recommended operating frequency range ² [MHz]	Output load ³ (max) [pF]	Recommended operating frequency range ² [MHz]	Output load ³ (max) [pF]				Oscillator stop function	Output state
CF5009AL1	Up to 40	50	Up to 40	50	CMOS	f_O	CMOS	Yes	Hi-Z
CF5009AL2						$f_O/2$			
CF5009AL3						$f_O/4$			
CF5009AL4						$f_O/8$			
CF5009AL5						$f_O/16$			
CF5009AL6						$f_O/32$			
CF5009AN1	Up to 40	30	Up to 40	50	CMOS	f_O	TTL	No	Hi-Z
CF5009AN2					$f_O/2$				
CF5009AN3					$f_O/4$				
CF5009AN4					$f_O/8$				
CF5009AN5					$f_O/16$				
CF5009AN6					$f_O/32$				
CF5009CN1	Up to 30	15	Up to 30	50	CMOS	f_O	TTL	No	Hi-Z
CF5009CN2					$f_O/2$				
CF5009AK1	-	-	Up to 40	15	TTL	f_O	TTL	No	Hi-Z
CF5009AK2					$f_O/2$				
CF5009AH1	Up to 16	15	Up to 30	15	CMOS	f_O	TTL	No	Hi-Z
CF5009AH2						$f_O/2$			
CF5009AH3						$f_O/4$			
CF5009AH4						$f_O/8$			

1. Package devices (8-pin SOP) have designation SM5009×××S.
2. The recommended operating frequency is a yardstick value derived from the crystal used for NPC characteristics authentication. However, the oscillator frequency band is not guaranteed. Specifically, the characteristics can vary greatly due to crystal characteristics and mounting conditions, so the oscillation characteristics of components must be carefully evaluated.
3. Output load value is the maximum load capacitance that allows drive.

APPLICATIONS

- SMD type crystal oscillator module

ORDERING INFORMATION

Device	Package
SM5009×××S	8-pin SOP
CF5009×××-1	Chip form

PAD LAYOUT

(Unit: μm)

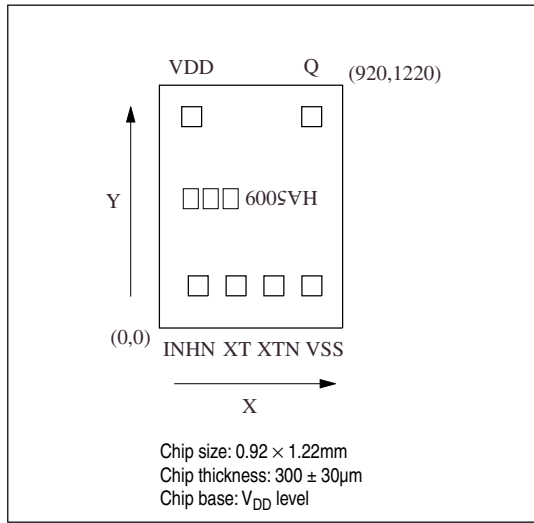

PINOUT

(Top view)

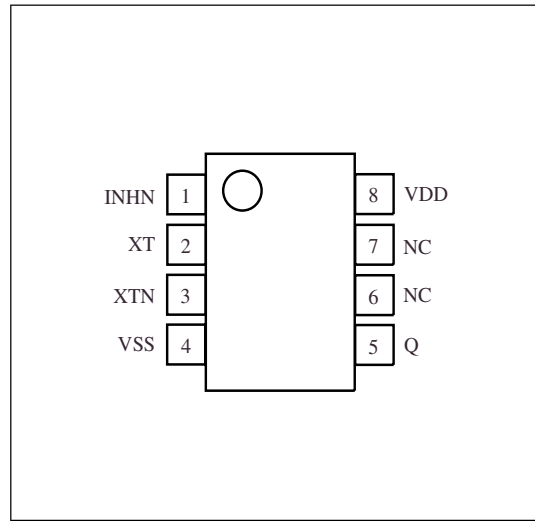

PIN DESCRIPTION and PAD DIMENSIONS

Number	Name	I/O	Description	Pad dimensions [μm]	
				X	Y
1	INHN	I	Output state control input. Standby mode when LOW, pull-up resistor built-in. In the case of the CF5009AL \times , the oscillator stops and power-saving pull-up resistor built in to reduce current consumption at standby mode.	195	212
2	XT	I	Amplifier input.	385	212
3	XTN	O	Amplifier output.		
			Crystal oscillator connection pins. Crystal oscillator connected between XT and XTN	575	212
4	VSS	-	Ground	766	212
5	Q	O	Output. Output frequency ($f_0, f_0/2, f_0/4, f_0/8, f_0/16, f_0/32$) determined by internal connection	765	1062
6	NC	-	No connection	-	-
7	NC	-	No connection	-	-
8	VDD	-	Supply voltage	162	1062

PACKAGE DIMENSIONS

(Unit: mm)

- 8-pin SOP

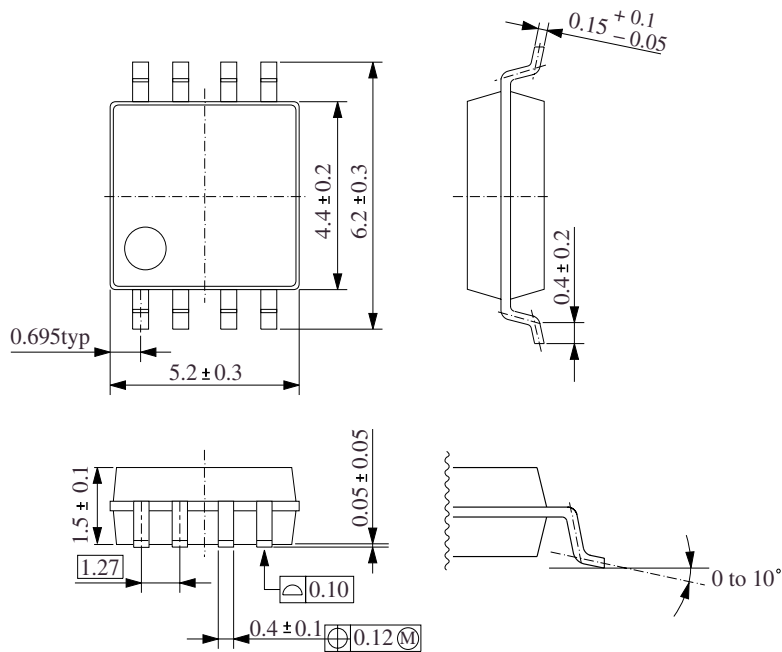

BLOCK DIAGRAM

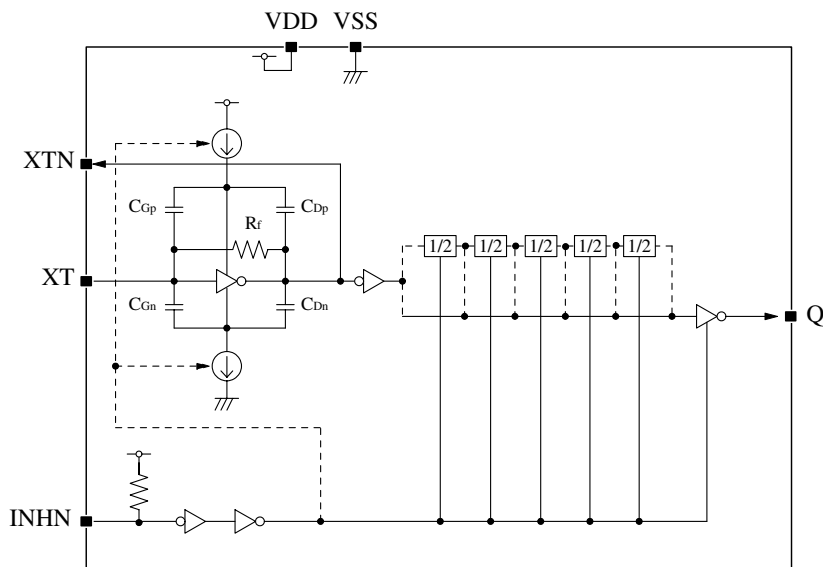

Notes. The SM5009 series reduce crystal current by limiting driving current of oscillating-stage inverter and inhibiting oscillating amplitude. Depending on the characteristics of using crystal or the mounting condition, they may not oscillate normally. Please evaluate the oscillation start-up characteristics adequately with your actual device.

FUNCTIONAL DESCRIPTION

Standby Function

5009 AL× series

When INHN goes LOW, the oscillator stops and the oscillator output on Q becomes high impedance.

5009AH×, AK×, AN×, CN× series

When INHN goes LOW, the output on Q becomes high impedance, but internally the oscillator does not stop.

Version	INHN	Q	Oscillator
AL× series	HIGH (or open)	Any f_O , $f_O/2$, $f_O/4$, $f_O/8$, $f_O/16$ or $f_O/32$ output frequency	Normal operation
	LOW	High impedance	Stopped
AH×, AK×, AN×, CN× series	HIGH (or open)	Any f_O , $f_O/2$, $f_O/4$, $f_O/8$, $f_O/16$ or $f_O/32$ output frequency	Normal operation
	LOW	High impedance	Normal operation

Power-saving Pull-up Resistor (AL× series only)

The INHN pull-up resistance changes in response to the input level (HIGH or LOW). When INHN goes LOW (standby state), the pull-up resistance becomes large to reduce the current consumption during standby.

Current consumption and Output waveform with NPC's standard crystal

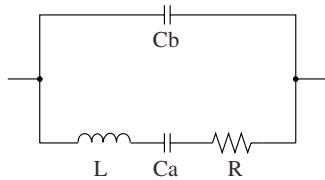

f [MHz]	R [Ω]	L [mH]	Ca [fF]	Cb [pF]
30	17.2	4.36	6.46	2.26
40	16.8	2.90	5.47	2.08

SPECIFICATIONS

Absolute Maximum Ratings

$V_{SS} = 0V$ unless otherwise noted.

Parameter	Symbol	Condition	Rating	Unit
Supply voltage range	V_{DD}		-0.5 to +7.0	V
Input voltage range	V_{IN}		-0.5 to $V_{DD} + 0.5$	V
Output voltage range	V_{OUT}		-0.5 to $V_{DD} + 0.5$	V
Operating temperature range	T_{opr}		-40 to +85	°C
Storage temperature range	T_{stg}	Chip form	-65 to +150	°C
		8-pin SOP	-55 to +125	
Output current	I_{OUT}		25	mA
Power dissipation	P_D	8-pin SOP	500	mW

Recommended Operating Conditions

$V_{SS} = 0V$ unless otherwise noted.

Parameter	Symbol	Version	Condition	Rating			Unit	
				min	typ	max		
Supply voltage	V_{DD}	AH×	$f \leq 30\text{MHz}$	4.5	-	5.5	V	
			$f \leq 16\text{MHz}$	2.7	-	3.3		
		AK×	$f \leq 40\text{MHz}$	4.5	-	5.5	V	
			$f \leq 40\text{MHz}$	2.7	-	5.5		
		CN×	$f \leq 30\text{MHz}$	2.7	-	5.5	V	
			AL×	Chip form	$f \leq 40\text{MHz}$	2.7		-
		$f \leq 30\text{MHz}$			2.3	-	2.7	
		$f \leq 20\text{MHz}$		2.25	-	2.75		
		8-pin SOP		$f \leq 40\text{MHz}$	2.7	-	5.5	
			$f \leq 14.4\text{MHz}$	2.4	-	2.7		
Input voltage	V_{IN}	All version		V_{SS}	-	V_{DD}	V	
Operating temperature	T_{OPR}	AH×	$f \leq 30\text{MHz}, 4.5V \leq V_{DD} \leq 5.5V$	-40	-	+85	°C	
			$f \leq 16\text{MHz}, 2.7V \leq V_{DD} \leq 3.6V$	-20	-	+80		
		AK×	$f \leq 30\text{MHz}$	-40	-	+85	°C	
			$30\text{MHz} < f \leq 40\text{MHz}$	-20	-	+80		
		AN×	Chip form	$f \leq 40\text{MHz}, 2.7V \leq V_{DD} < 4.5V$	-20	-	+80	°C
				$f \leq 40\text{MHz}, 4.5V \leq V_{DD} \leq 5.5V$	-40	-	+85	
			8-pin SOP	$f \leq 40\text{MHz}, 2.7V \leq V_{DD} < 4.5V$	-20	-	+80	
				$f \leq 40\text{MHz}, 4.5V \leq V_{DD} \leq 5.5V$	-20	-	+80	
		CN×	$f \leq 30\text{MHz}, 2.7V \leq V_{DD} < 4.5V$	-10	-	+70	°C	
			$f \leq 30\text{MHz}, 4.5V \leq V_{DD} \leq 5.5V$	-40	-	+85		
		AL×	Chip form	$f \leq 40\text{MHz}, 2.7V \leq V_{DD} \leq 5.5V$	-40	-	+85	°C
				$f \leq 30\text{MHz}, 2.3V \leq V_{DD} \leq 2.7V$	-20	-	+80	
				$f \leq 20\text{MHz}, 2.25V \leq V_{DD} \leq 2.75V$	-20	-	+80	
			8-pin SOP	$f \leq 40\text{MHz}, 2.7V \leq V_{DD} \leq 5.5V$	-20	-	+80	
				$f \leq 30\text{MHz}, 2.7V \leq V_{DD} \leq 5.5V$	-40	-	+85	
				$f \leq 14.4\text{MHz}, 2.4V \leq V_{DD} \leq 2.7V$	-20	-	+80	

Electrical Characteristics

5009AL× series

3V operation: $V_{DD} = 2.7$ to $3.3V$, $V_{SS} = 0V$, $T_a = -40$ to $85^\circ C$ unless otherwise noted.

Parameter	Symbol	Condition	Rating			Unit	
			min	typ	max		
HIGH-level output voltage	V_{OH}	Q: Measurement cct 1, $I_{OH} = 8mA$	2.2	–	–	V	
LOW-level output voltage	V_{OL}	Q: Measurement cct 1, $I_{OL} = 8mA$	–	–	0.4	V	
HIGH-level input voltage	V_{IH}	INH N	$0.7V_{DD}$	–	–	V	
LOW-level input voltage	V_{IL}	INH N	–	–	$0.3V_{DD}$	V	
Output leakage current	I_Z	Q: Measurement cct 2, INHN = LOW, $V_{OH} = V_{DD}$	–	–	10	μA	
		Q: Measurement cct 2, INHN = LOW, $V_{OL} = V_{SS}$	–	–	10		
Current consumption	I_{DD}	INH N = open, Measurement cct 3, load cct 2, $C_L = 15pF$, 40MHz crystal oscillator	CF5009AL1	–	8	17	mA
			CF5009AL2	–	5	11	
			CF5009AL3	–	4	9	
			CF5009AL4	–	3	7	
			CF5009AL5	–	3	6	
			CF5009AL6	–	2	5	
		INH N = open, Measurement cct 3, load cct 2, $C_L = 15pF$, 40MHz crystal oscillator, $T_a = -20$ to $+80^\circ C$	SM5009AL1S	–	8	17	
			SM5009AL2S	–	5	11	
			SM5009AL3S	–	4	9	
			SM5009AL4S	–	3	7	
			SM5009AL5S	–	3	6	
			SM5009AL6S	–	2	5	
Standby current	I_{ST}	INH N = V_{SS} , Measurement cct 3	–	2	5	μA	
INH N pull-up resistance	R_{UP1}	Measurement cct 4, $V_{DD} = 3V$, INHN = V_{SS}	0.6	–	12	$M\Omega$	
	R_{UP2}	Measurement cct 4, $V_{DD} = 3V$, INHN = 2.1V	40	–	200	$k\Omega$	
Negative resistance	$-R_L$	$V_{DD} = 3V$, $T_a = 25^\circ C$, 40MHz	–	–200	–	Ω	
Feedback resistance	R_f	Measurement cct 5	0.4	–	1.1	$M\Omega$	
Built-in capacitance	C_G	Design value. A monitor pattern on a wafer is tested.	5.58	6	6.42	pF	
	C_D		9.3	10	10.7	pF	

SM5009 series

5V operation: $V_{DD} = 4.5$ to $5.5V$, $V_{SS} = 0V$, $T_a = -40$ to $85^\circ C$ unless otherwise noted.

Parameter	Symbol	Condition	Rating			Unit	
			min	typ	max		
HIGH-level output voltage	V_{OH}	Q: Measurement cct 1, $I_{OH} = 16mA$	4.0	–	–	V	
LOW-level output voltage	V_{OL}	Q: Measurement cct 1, $I_{OL} = 16mA$	–	–	0.4	V	
HIGH-level input voltage	V_{IH}	INH N	$0.7V_{DD}$	–	–	V	
LOW-level input voltage	V_{IL}	INH N	–	–	$0.3V_{DD}$	V	
Output leakage current	I_Z	Q: Measurement cct 2, INHN = LOW, $V_{OH} = V_{DD}$	–	–	10	μA	
		Q: Measurement cct 2, INHN = LOW, $V_{OL} = V_{SS}$	–	–	10		
Current consumption	I_{DD}	INH N = open, Measurement cct 3, load cct 2, $C_L = 15pF$, 40MHz crystal oscillator	CF5009AL1	–	12	26	mA
			CF5009AL2	–	8	17	
			CF5009AL3	–	6	13	
			CF5009AL4	–	5	11	
			CF5009AL5	–	5	10	
			CF5009AL6	–	4	9	
		INH N = open, Measurement cct 3, load cct 2, $C_L = 15pF$, 40MHz crystal oscillator, $T_a = -20$ to $+80^\circ C$	SM5009AL1S	–	12	26	
			SM5009AL2S	–	8	17	
			SM5009AL3S	–	6	13	
			SM5009AL4S	–	5	11	
			SM5009AL5S	–	5	10	
			SM5009AL6S	–	4	9	
Standby current	I_{ST}	INH N = V_{SS} , Measurement cct 3	–	6	15	μA	
INH N pull-up resistance	R_{UP1}	Measurement cct 4, $V_{DD} = 5V$, INHN = V_{SS}	0.3	–	6	$M\Omega$	
	R_{UP2}	Measurement cct 4, $V_{DD} = 5V$, INHN = 3.5V	40	–	200	$k\Omega$	
Negative resistance	$-R_L$	$V_{DD} = 5V$, $T_a = 25^\circ C$, 40MHz	–	–400	–	Ω	
Feedback resistance	R_f	Measurement cct 5	0.4	–	1.1	$M\Omega$	
Built-in capacitance	C_G	Design value. A monitor pattern on a wafer is tested.	5.58	6	6.42	pF	
	C_D		9.3	10	10.7	pF	

SM5009 series

5009AN×/CN× series

3V operation: $V_{DD} = 2.7$ to $3.3V$, $V_{SS} = 0V$, $T_a = -20$ to $80^\circ C$ unless otherwise noted.

Parameter	Symbol	Condition	Rating			Unit	
			min	typ	max		
HIGH-level output voltage	V_{OH}	Q: Measurement cct 1, $I_{OH} = 8mA$	SM5009AN1S, CF5009AN1 SM5009AN2S, CF5009AN2	2.2	-	-	V
			SM5009AN3S, CF5009AN3 SM5009AN4S, CF5009AN4 SM5009AN5S, CF5009AN5 SM5009AN6S, CF5009AN6 SM5009CN1S, CF5009CN1 SM5009CN2S, CF5009CN2	2.1	-	-	
LOW-level output voltage	V_{OL}	Q: Measurement cct 1, $I_{OL} = 8mA$	-	-	0.4	V	
HIGH-level input voltage	V_{IH}	INH N	2.0	-	-	V	
LOW-level input voltage	V_{IL}	INH N	-	-	0.3	V	
Output leakage current	I_Z	Q: Measurement cct 2, INHN = LOW, $V_{OH} = V_{DD}$	-	-	10	μA	
		Q: Measurement cct 2, INHN = LOW, $V_{OL} = V_{SS}$	-	-	10		
Current consumption	I_{DD}	INH N = open, Measurement cct 3, load cct 2, $C_L = 15pF$, 40MHz crystal oscillator	SM5009AN1S, CF5009AN1	-	8	17	mA
			SM5009AN2S, CF5009AN2	-	5	11	
			SM5009AN3S, CF5009AN3	-	4	9	
			SM5009AN4S, CF5009AN4	-	3	7	
			SM5009AN5S, CF5009AN5	-	3	6	
			SM5009AN6S, CF5009AN6	-	2	5	
		INH N = open, Measurement cct 3, load cct 2, $C_L = 15pF$, 30MHz crystal oscillator, $T_a = -10$ to $+70^\circ C$	SM5009CN1S, CF5009CN1	-	7	15	
			SM5009CN2S, CF5009CN2	-	4	9	
INH N pull-up resistance	R_{UP}	Measurement cct 4, $V_{DD} = 3V$, INHN = V_{SS}	40	-	200	$k\Omega$	
Negative resistance	$-R_L$	$V_{DD} = 3V$, $T_a = 25^\circ C$, 40MHz	-	-100	-	Ω	
Feedback resistance	R_f	Measurement cct 5	0.4	-	1.1	$M\Omega$	
Built-in capacitance	C_G	Design value. A monitor pattern on a wafer is tested.	5.58	6	6.42	pF	
	C_D		9.3	10	10.7	pF	

SM5009 series

5V operation: $V_{DD} = 4.5$ to $5.5V$, $V_{SS} = 0V$, $T_a = -40$ to $85^\circ C$ unless otherwise noted.

Parameter	Symbol	Condition	Rating			Unit	
			min	typ	max		
HIGH-level output voltage	V_{OH}	Q: Measurement cct 1, $I_{OH} = 16mA$	SM5009AN1S, CF5009AN1 SM5009AN2S, CF5009AN2	4.0	-	-	V
			SM5009AN3S, CF5009AN3 SM5009AN4S, CF5009AN4 SM5009AN5S, CF5009AN5 SM5009AN6S, CF5009AN6 SM5009CN1S, CF5009CN1 SM5009CN2S, CF5009CN2	3.9	-	-	
LOW-level output voltage	V_{OL}	Q: Measurement cct 1, $I_{OL} = 16mA$	-	-	0.4	V	
HIGH-level input voltage	V_{IH}	INH N	2.0	-	-	V	
LOW-level input voltage	V_{IL}	INH N	-	-	0.8	V	
Output leakage current	I_Z	Q: Measurement cct 2, INHN = LOW, $V_{OH} = V_{DD}$	-	-	10	μA	
		Q: Measurement cct 2, INHN = LOW, $V_{OL} = V_{SS}$	-	-	10		
Current consumption	I_{DD}	INH N = open, Measurement cct 3, load cct 2, $C_L = 15pF$, 40MHz crystal oscillator	CF5009AN1	-	12	26	mA
			CF5009AN2	-	8	17	
			CF5009AN3	-	6	13	
			CF5009AN4	-	5	11	
			CF5009AN5	-	5	10	
			CF5009AN6	-	4	9	
		INH N = open, Measurement cct 3, load cct 2, $C_L = 15pF$, 40MHz crystal oscillator, $T_a = -20$ to $+80^\circ C$	SM5009AN1S	-	12	26	
			SM5009AN2S	-	8	17	
			SM5009AN3S	-	6	13	
			SM5009AN4S	-	5	11	
			SM5009AN5S	-	5	10	
			SM5009AN6S	-	4	9	
		INH N = open, Measurement cct 3, load cct 2, $C_L = 15pF$, 30MHz crystal oscillator	SM5009CN1S, CF5009CN1	-	10	22	
			SM5009CN2S, CF5009CN2	-	7	15	
INH N pull-up resistance	R_{UP}	Measurement cct 4, $V_{DD} = 5V$, INHN = V_{SS}	40	-	200	k Ω	
Negative resistance	$-R_L$	$V_{DD} = 5V$, $T_a = 25^\circ C$, 40MHz	-	-210	-	Ω	
Feedback resistance	R_f	Measurement cct 5	0.4	-	1.1	M Ω	
Built-in capacitance	C_G	Design value. A monitor pattern on a wafer is tested.	5.58	6	6.42	pF	
	C_D		9.3	10	10.7	pF	

SM5009 series

5009AK× series

$V_{DD} = 4.5$ to $5.5V$, $V_{SS} = 0V$, $T_a = -40$ to $85^{\circ}C$ unless otherwise noted.

Parameter	Symbol	Condition	Rating			Unit	
			min	typ	max		
HIGH-level output voltage	V_{OH}	Q: Measurement cct 1, $I_{OH} = 16mA$	4.0	–	–	V	
LOW-level output voltage	V_{OL}	Q: Measurement cct 1, $I_{OL} = 16mA$	–	–	0.4	V	
HIGH-level input voltage	V_{IH}	INH N	2.0	–	–	V	
LOW-level input voltage	V_{IL}	INH N	–	–	0.8	V	
Output leakage current	I_Z	Q: Measurement cct 2, INHN = LOW, $V_{OH} = V_{DD}$	–	–	10	μA	
		Q: Measurement cct 2, INHN = LOW, $V_{OL} = V_{SS}$	–	–	10		
Current consumption	I_{DD}	INHN = open, Measurement cct 3, load cct 1, $C_L = 15pF$, 40MHz crystal oscillator, $T_a = -20$ to $+80^{\circ}C$	SM5009AK1S	–	12	26	mA
			CF5009AK1	–	12	26	
			SM5009AK2S	–	8	17	
			CF5009AK2	–	8	17	
INH N pull-up resistance	R_{UP}	Measurement cct 4, $V_{DD} = 5V$, INHN = V_{SS}	40	–	200	$k\Omega$	
Negative resistance	$-R_L$	$V_{DD} = 5V$, $T_a = 25^{\circ}C$, 40MHz	–	-210	–	Ω	
Feedback resistance	R_f	Measurement cct 5	0.4	–	1.1	$M\Omega$	
Built-in capacitance	C_G	Design value. A monitor pattern on a wafer is tested.	5.58	6	6.42	pF	
	C_D		9.3	10	10.7	pF	

SM5009 series

5009AH× series

3V operation: $V_{DD} = 2.7$ to $3.3V$, $V_{SS} = 0V$, $T_a = -20$ to $80^\circ C$ unless otherwise noted.

Parameter	Symbol	Condition	Rating			Unit	
			min	typ	max		
HIGH-level output voltage	V_{OH}	Q: Measurement cct 1, $I_{OH} = 2mA$	2.2	–	–	V	
LOW-level output voltage	V_{OL}	Q: Measurement cct 1, $I_{OL} = 2mA$	–	–	0.4	V	
HIGH-level input voltage	V_{IH}	INH N	2.0	–	–	V	
LOW-level input voltage	V_{IL}	INH N	–	–	0.3	V	
Output leakage current	I_Z	Q: Measurement cct 2, INHN = LOW, $V_{OH} = V_{DD}$	–	–	10	μA	
		Q: Measurement cct 2, INHN = LOW, $V_{OL} = V_{SS}$	–	–	10		
Current consumption	I_{DD}	INH N = open, Measurement cct 3, load cct 2, $C_L = 15pF$, 16MHz crystal oscillator	SM5009AH1S CF5009AH1	–	4.5	10	mA
			SM5009AH2S CF5009AH2	–	3	7	
			SM5009AH3S CF5009AH3 SM5009AH4S CF5009AH4	–	1.5	3.5	
INH N pull-up resistance	R_{UP}	Measurement cct 4, $V_{DD} = 3V$, INHN = V_{SS}	40	–	200	k Ω	
Negative resistance	$-R_L$	$V_{DD} = 3V$, $T_a = 25^\circ C$, 16MHz	–	–450	–	Ω	
Feedback resistance	R_f	Measurement cct 5	0.4	–	1.1	M Ω	
Built-in capacitance	C_G	Design value. A monitor pattern on a wafer is tested.	5.58	6	6.42	pF	
	C_D		9.3	10	10.7	pF	

5V operation: $V_{DD} = 4.5$ to $5.5V$, $V_{SS} = 0V$, $T_a = -40$ to $85^\circ C$ unless otherwise noted.

Parameter	Symbol	Condition	Rating			Unit	
			min	typ	max		
HIGH-level output voltage	V_{OH}	Q: Measurement cct 1, $I_{OH} = 4mA$	4.0	–	–	V	
LOW-level output voltage	V_{OL}	Q: Measurement cct 1, $I_{OL} = 4mA$	–	–	0.4	V	
HIGH-level input voltage	V_{IH}	INH N	2.0	–	–	V	
LOW-level input voltage	V_{IL}	INH N	–	–	0.8	V	
Output leakage current	I_Z	Q: Measurement cct 2, INHN = LOW, $V_{OH} = V_{DD}$	–	–	10	μA	
		Q: Measurement cct 2, INHN = LOW, $V_{OL} = V_{SS}$	–	–	10		
Current consumption	I_{DD}	INH N = open, Measurement cct 3, load cct 2, $C_L = 15pF$, 30MHz crystal oscillator	SM5009AH1S CF5009AH1	–	9	20	mA
			SM5009AH2S CF5009AH2	–	6	13	
			SM5009AH3S CF5009AH3 SM5009AH4S CF5009AH4	–	4	9	
INH N pull-up resistance	R_{UP}	Measurement cct 4, $V_{DD} = 5V$, INHN = V_{SS}	40	–	200	k Ω	
Negative resistance	$-R_L$	$V_{DD} = 5V$, $T_a = 25^\circ C$, 30MHz	–	–340	–	Ω	
Feedback resistance	R_f	Measurement cct 5	0.4	–	1.1	M Ω	
Built-in capacitance	C_G	Design value. A monitor pattern on a wafer is tested.	5.58	6	6.42	pF	
	C_D		9.3	10	10.7	pF	

Switching Characteristics

5009AL× series

3V operation: $V_{DD} = 2.7$ to $3.3V$, $V_{SS} = 0V$, $T_a = -40$ to $85^\circ C$ unless otherwise noted.

Parameter	Symbol	Condition	Rating			Unit	
			min	typ	max		
Output rise time	t_{r1}	Measurement cct 3, load cct 2, $0.1V_{DD}$ to $0.9V_{DD}$, $C_L = 15pF$	–	3.5	9	ns	
		Measurement cct 3, load cct 2, $0.1V_{DD}$ to $0.9V_{DD}$, $V_{DD} = 2.3$ to $2.7V$, $T_a = -20$ to $+80^\circ C$, $C_L = 15pF$	–	4	13		
	t_{r2}	Measurement cct 3, load cct 2, $0.1V_{DD}$ to $0.9V_{DD}$, $C_L = 30pF$	–	5	12		
		Measurement cct 3, load cct 2, $0.1V_{DD}$ to $0.9V_{DD}$, $V_{DD} = 2.4$ to $2.7V$, $T_a = -20$ to $+80^\circ C$, $C_L = 30pF$	–	5.5	16		
	t_{r3}	Measurement cct 3, load cct 2, $0.1V_{DD}$ to $0.9V_{DD}$, $V_{DD} = 3.0$ to $3.6V$, $f \leq 30MHz$, $C_L = 50pF$	–	5	12		
		Measurement cct 3, load cct 2, $0.2V_{DD}$ to $0.8V_{DD}$, $V_{DD} = 3.0$ to $3.6V$, $f \leq 40MHz$, $C_L = 50pF$	–	3.5	12		
Output fall time	t_{f1}	Measurement cct 3, load cct 2, $0.9V_{DD}$ to $0.1V_{DD}$, $C_L = 15pF$	–	3.5	9	ns	
		Measurement cct 3, load cct 2, $0.9V_{DD}$ to $0.1V_{DD}$, $V_{DD} = 2.3$ to $2.7V$, $T_a = -20$ to $+80^\circ C$, $C_L = 15pF$	–	4	13		
	t_{f2}	Measurement cct 3, load cct 2, $0.9V_{DD}$ to $0.1V_{DD}$, $C_L = 30pF$	–	5	12		
		Measurement cct 3, load cct 2, $0.9V_{DD}$ to $0.1V_{DD}$, $V_{DD} = 2.4$ to $2.7V$, $T_a = -20$ to $+80^\circ C$, $C_L = 30pF$	–	5.5	16		
	t_{f3}	Measurement cct 3, load cct 2, $0.9V_{DD}$ to $0.1V_{DD}$, $V_{DD} = 3.0$ to $3.6V$, $f \leq 30MHz$, $C_L = 50pF$	–	5	12		
		Measurement cct 3, load cct 2, $0.8V_{DD}$ to $0.2V_{DD}$, $V_{DD} = 3.0$ to $3.6V$, $f \leq 40MHz$, $C_L = 50pF$	–	3.5	12		
Output duty cycle ¹	Duty1	Measurement cct 3, load cct 2, $V_{DD} = 3V$, $f \leq 40MHz$, $T_a = 25^\circ C$, $C_L = 30pF$	45	–	55	%	
		Measurement cct 3, load cct 2, $V_{DD} = 2.4V$, $f \leq 14.4MHz$, $T_a = 25^\circ C$, $C_L = 30pF$	40	–	60		
		CF5009AL× only, Measurement cct 3, load cct 2, $V_{DD} = 2.5V$, $f \leq 30MHz$, $T_a = 25^\circ C$, $C_L = 15pF$	40	–	60		
	Duty2	CF5009AL× only, Measurement cct 3, load cct 2, $V_{DD} = 3.3V$, $f \leq 30MHz$, $T_a = 25^\circ C$, $C_L = 50pF$	45	–	55		
		CF5009AL× only, Measurement cct 3, load cct 2, $V_{DD} = 3.3V$, $f \leq 40MHz$, $T_a = 25^\circ C$, $C_L = 50pF$	40	–	60		
Output disable delay time ²	t_{PLZ}	Measurement cct 6, load cct 2, $V_{DD} = 3V$, $T_a = 25^\circ C$, $C_L \leq 15pF$	–	–	100	ns	
Output enable delay time ²	t_{PZL}		–	–	100	ns	
Maximum operating frequency	f_{max}	Measurement cct 3	CF5009AL×	40	–	–	MHz
			SM5009AL×S	30	–	–	
		Measurement cct 3, $T_a = -20$ to $+80^\circ C$	SM5009AL×S	40	–	–	
			$V_{DD} = 2.4$ to $2.7V$, SM5009AL×S	14.4	–	–	
		Measurement cct 3, $T_a = -20$ to $+80^\circ C$	$V_{DD} = 2.3$ to $2.7V$, CF5009AL×	30	–	–	
			$V_{DD} = 2.25$ to $2.75V$, CF5009AL×	20	–	–	

1. The duty cycle characteristic is checked the sample chips of each production lot.

2. Oscillator stop function is built-in. When INHN goes LOW, normal output stops. When INHN goes HIGH, normal output is not resumed until after the oscillator start-up time has elapsed.

SM5009 series

5V operation: $V_{DD} = 4.5$ to $5.5V$, $V_{SS} = 0V$, $T_a = -40$ to $85^\circ C$ unless otherwise noted.

Parameter	Symbol	Condition	Rating			Unit		
			min	typ	max			
Output rise time	t_{r1}	Measurement cct 3, load cct 2, $0.1V_{DD}$ to $0.9V_{DD}$	$C_L = 15pF$	–	2	4	ns	
	t_{r2}		$C_L = 30pF$	–	3.5	7		
	t_{r3}		$C_L = 50pF$	–	4	8		
Output fall time	t_{f1}	Measurement cct 3, load cct 2, $0.9V_{DD}$ to $0.1V_{DD}$	$C_L = 15pF$	–	2	4	ns	
	t_{f2}		$C_L = 30pF$	–	3.5	7		
	t_{f3}		$C_L = 50pF$	–	4	8		
Output duty cycle ¹	Duty	Measurement cct 3, load cct 2, $V_{DD} = 5V$, $T_a = 25^\circ C$, $C_L = 50pF$			45	–	55	%
Output disable delay time ²	t_{PLZ}	Measurement cct 6, load cct 2, $V_{DD} = 5V$, $T_a = 25^\circ C$, $C_L \leq 15pF$			–	–	100	ns
Output enable delay time ²	t_{PZL}				–	–	100	ns
Maximum operating frequency	f_{max}	Measurement cct 3	CF5009AL×	40	–	–	MHz	
			SM5009AL×S	30	–	–		
		Measurement cct 3, $T_a = -20$ to $+80^\circ C$	SM5009AL×S	40	–	–		

1. The duty cycle characteristic is checked the sample chips of each production lot.
2. Oscillator stop function is built-in. When INHN goes LOW, normal output stops. When INHN goes HIGH, normal output is not resumed until after the oscillator start-up time has elapsed.

SM5009 series

5009AN×/CN× series

3V operation: $V_{DD} = 2.7$ to $3.3V$, $V_{SS} = 0V$, $T_a = -20$ to $80^\circ C$ unless otherwise noted.

Parameter	Symbol	Condition	Rating			Unit	
			min	typ	max		
Output rise time	t_{r1}	Measurement cct 3, load cct 2, $0.1V_{DD}$ to $0.9V_{DD}$, $C_L = 15pF$	SM5009AN1S, CF5009AN1 SM5009AN2S, CF5009AN2	–	3.5	9	ns
			SM5009AN3S, CF5009AN3 SM5009AN4S, CF5009AN4 SM5009AN5S, CF5009AN5 SM5009AN6S, CF5009AN6 SM5009CN1S, CF5009CN1 SM5009CN2S, CF5009CN2	–	5	13	
	t_{r2}	Measurement cct 3, load cct 2, $0.1V_{DD}$ to $0.9V_{DD}$, $C_L = 30pF$	SM5009AN1S, CF5009AN1 SM5009AN2S, CF5009AN2	–	5	12	
			SM5009AN3S, CF5009AN3 SM5009AN4S, CF5009AN4 SM5009AN5S, CF5009AN5 SM5009AN6S, CF5009AN6 SM5009CN1S, CF5009CN1 SM5009CN2S, CF5009CN2	–	7	16	
Output fall time	t_{f1}	Measurement cct 3, load cct 2, $0.9V_{DD}$ to $0.1V_{DD}$, $C_L = 15pF$	SM5009AN1S, CF5009AN1 SM5009AN2S, CF5009AN2	–	3.5	9	ns
			SM5009AN3S, CF5009AN3 SM5009AN4S, CF5009AN4 SM5009AN5S, CF5009AN5 SM5009AN6S, CF5009AN6 SM5009CN1S, CF5009CN1 SM5009CN2S, CF5009CN2	–	5	13	
	t_{f2}	Measurement cct 3, load cct 2, $0.9V_{DD}$ to $0.1V_{DD}$, $C_L = 30pF$	SM5009AN1S, CF5009AN1 SM5009AN2S, CF5009AN2	–	5	12	
			SM5009AN3S, CF5009AN3 SM5009AN4S, CF5009AN4 SM5009AN5S, CF5009AN5 SM5009AN6S, CF5009AN6 SM5009CN1S, CF5009CN1 SM5009CN2S, CF5009CN2	–	7	16	
Output duty cycle ¹	Duty	Measurement cct 3, load cct 2, $V_{DD} = 3V$, $T_a = 25^\circ C$	$C_L = 30 pF$, SM5009AN×S, CF5009AN×	45	–	55	%
			$C_L = 15 pF$, SM5009CN×S, CF5009CN×	40	–	60	
Output disable delay time	t_{PLZ}	Measurement cct 6, load cct 2, $V_{DD} = 3V$, $T_a = 25^\circ C$, $C_L \leq 15pF$	–	–	100	ns	
Output enable delay time	t_{PZL}		–	–	100	ns	
Maximum operating frequency	f_{max}	Measurement cct 3	SM5009AN×S, CF5009AN×	40	–	–	MHz
			$T_a = -10$ to $+70^\circ C$, SM5009CN×S, CF5009CN×	30	–	–	

1. The duty cycle characteristic is checked the sample chips of each production lot.

SM5009 series

5V operation: $V_{DD} = 4.5$ to $5.5V$, $V_{SS} = 0V$, $T_a = -40$ to $85^\circ C$ unless otherwise noted.

Parameter	Symbol	Condition	Rating			Unit		
			min	typ	max			
Output rise time	t_{r1}	Measurement cct 3, load cct 2, $0.1V_{DD}$ to $0.9V_{DD}$	$C_L = 15pF$	–	2	4	ns	
	t_{r2}		$C_L = 30pF$	–	3.5	7		
	t_{r3}		$C_L = 50pF$	–	4	8		
Output fall time	t_{f1}	Measurement cct 3, load cct 2, $0.9V_{DD}$ to $0.1V_{DD}$	$C_L = 15pF$	–	2	4	ns	
	t_{f2}		$C_L = 30pF$	–	3.5	7		
	t_{f3}		$C_L = 50pF$	–	4	8		
Output duty cycle ¹	Duty	Measurement cct 3, load cct 2, $V_{DD} = 5V$, $T_a = 25^\circ C$, $C_L = 50pF$			45	–	55	%
Output disable delay time	t_{PLZ}	Measurement cct 6, load cct 2, $V_{DD} = 5V$, $T_a = 25^\circ C$, $C_L \leq 15pF$			–	–	100	ns
Output enable delay time	t_{PZL}				–	–	100	ns
Maximum operating frequency	f_{max}	Measurement cct 3	SM5009AN×S, CF5009AN×	40	–	–	MHz	
			SM5009CN×S, CF5009CN×	30	–	–		

1. The duty cycle characteristic is checked the sample chips of each production lot.

5009AK× series

$V_{DD} = 4.5$ to $5.5V$, $V_{SS} = 0V$, $T_a = -40$ to $85^\circ C$ unless otherwise noted.

Parameter	Symbol	Condition	Rating			Unit			
			min	typ	max				
Output rise time	t_r	Measurement cct 3, load cct 1, $0.4V$ to $2.4V$, $C_L = 15pF$			–	2	6	ns	
Output fall time	t_f	Measurement cct 3, load cct 1, $2.4V$ to $0.4V$, $C_L = 15pF$			–	2	6	ns	
Output duty cycle ¹	Duty	Measurement cct 3, load cct 1, $V_{DD} = 5V$, $T_a = 25^\circ C$, $C_L = 15pF$			45	–	55	%	
Output disable delay time	t_{PLZ}	Measurement cct 6, load cct 1, $V_{DD} = 5V$, $T_a = 25^\circ C$, $C_L \leq 15pF$			–	–	100	ns	
Output enable delay time	t_{PZL}				–	–	100	ns	
Maximum operating frequency	f_{max}	Measurement cct 3	$T_a = -20$ to $+80^\circ C$			40	–	–	MHz
			$T_a = -40$ to $+85^\circ C$			30	–	–	

1. The duty cycle characteristic is checked the sample chips of each production lot.

SM5009 series

5009AH× series

3V operation: $V_{DD} = 2.7$ to $3.3V$, $V_{SS} = 0V$, $T_a = -20$ to $80^{\circ}C$ unless otherwise noted.

Parameter	Symbol	Condition	Rating			Unit
			min	typ	max	
Output rise time	t_{r1}	Measurement cct 3, load cct 2, $0.1V_{DD}$ to $0.9V_{DD}$, $C_L = 15pF$	–	6	18	ns
Output fall time	t_{f1}	Measurement cct 3, load cct 2, $0.9V_{DD}$ to $0.1V_{DD}$, $C_L = 15pF$	–	6	18	ns
Output duty cycle ¹	Duty	Measurement cct 3, load cct 2, $V_{DD} = 3V$, $T_a = 25^{\circ}C$, $C_L = 15pF$	45	–	55	%
Output disable delay time	t_{PLZ}	Measurement cct 6, load cct 2, $V_{DD} = 3V$, $T_a = 25^{\circ}C$, $C_L \leq 15pF$	–	–	100	ns
Output enable delay time	t_{PZL}		–	–	100	ns
Maximum operating frequency	f_{max}	Measurement cct 3	16	–	–	MHz

1. The duty cycle characteristic is checked the sample chips of each production lot.

5V operation: $V_{DD} = 4.5$ to $5.5V$, $V_{SS} = 0V$, $T_a = -40$ to $85^{\circ}C$ unless otherwise noted.

Parameter	Symbol	Condition	Rating			Unit
			min	typ	max	
Output rise time	t_{r1}	Measurement cct 3, load cct 2, $0.1V_{DD}$ to $0.9V_{DD}$, $C_L = 15pF$	–	4	12	ns
Output fall time	t_{f1}	Measurement cct 3, load cct 2, $0.9V_{DD}$ to $0.1V_{DD}$, $C_L = 15pF$	–	4	12	ns
Output duty cycle ¹	Duty	Measurement cct 3, load cct 2, $V_{DD} = 5V$, $T_a = 25^{\circ}C$, $C_L = 15pF$	45	–	55	%
Output disable delay time	t_{PLZ}	Measurement cct 6, load cct 2, $V_{DD} = 5V$, $T_a = 25^{\circ}C$, $C_L \leq 15pF$	–	–	100	ns
Output enable delay time	t_{PZL}		–	–	100	ns
Maximum operating frequency	f_{max}	Measurement cct 3	30	–	–	MHz

1. The duty cycle characteristic is checked the sample chips of each production lot.

MEASUREMENT CIRCUITS

Measurement cct 1

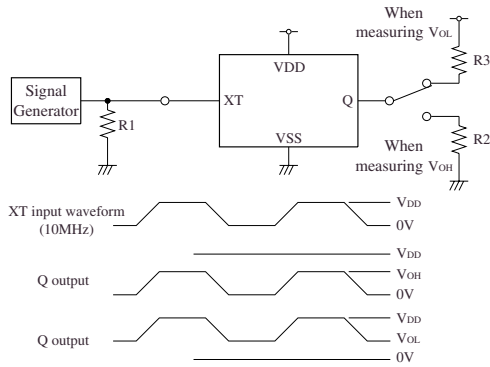

- 5009AKx, ALx, AN1, AN2
R1: 50Ω
R2: 250Ω (V_{DD} = 4.5V), 275Ω (V_{DD} = 2.7V)
R3: 256Ω (V_{DD} = 4.5V), 288Ω (V_{DD} = 2.7V)
- 5009AN3 to AN6, CNx
R1: 50Ω
R2: 245Ω (V_{DD} = 4.5V), 262Ω (V_{DD} = 2.7V)
R3: 256Ω (V_{DD} = 4.5V), 288Ω (V_{DD} = 2.7V)
- 5009AHx
R1: 50Ω
R2: 1000Ω (V_{DD} = 4.5V), 1100Ω (V_{DD} = 2.7V)
R3: 1025Ω (V_{DD} = 4.5V), 1150Ω (V_{DD} = 2.7V)

Measurement cct 2

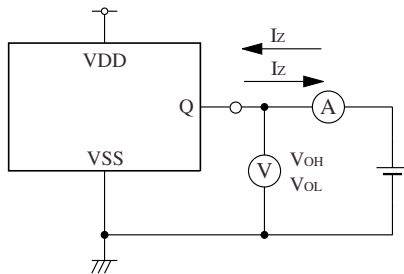

Measurement cct 3

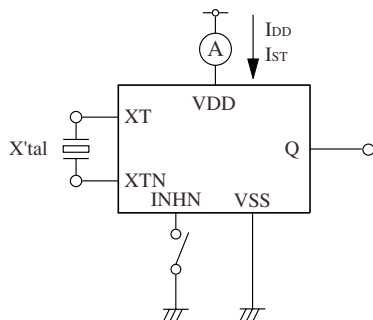

Measurement cct 4

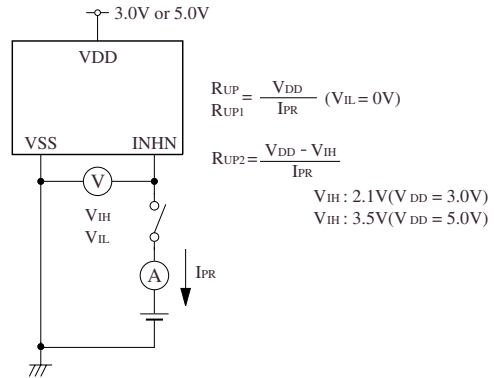

Measurement cct 5

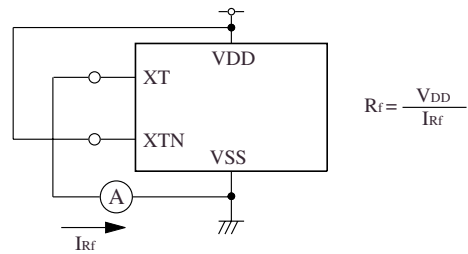

Measurement cct 6

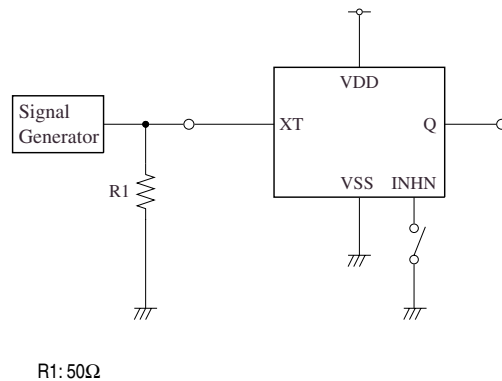

Load cct 1

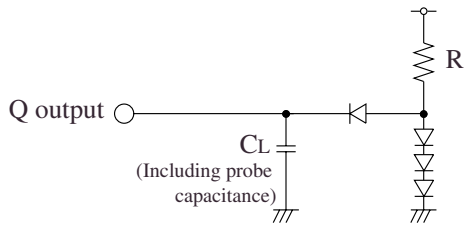

$C_L = 15\text{pF}$: DUTY, I_{DD} , t_r , t_f
 $R = 400\Omega$

Load cct 2

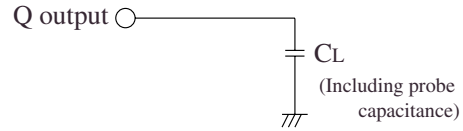

$C_L = 15\text{pF}$: DUTY, I_{DD} , t_{r1} , t_{f1}
 $C_L = 30\text{pF}$: t_{r2} , t_{f2}
 $C_L = 50\text{pF}$: t_{r3} , t_{f3}

Switching Time Measurement Waveform

Output duty level (CMOS)

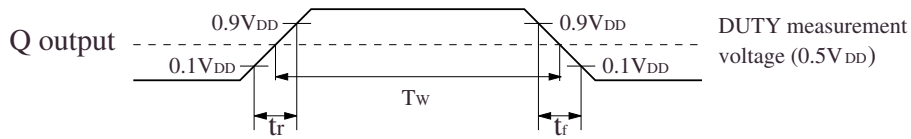

Output duty level (TTL)

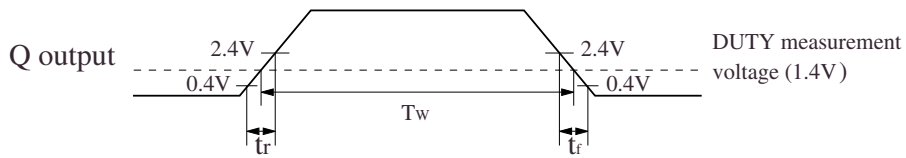

Output duty cycle (CMOS)

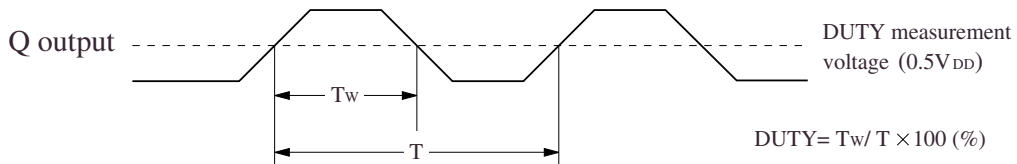

Output duty cycle (TTL)

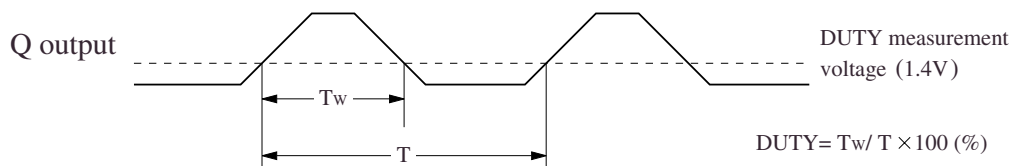

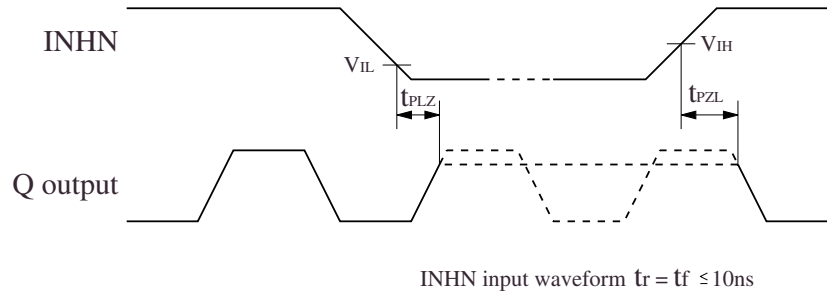
Output Enable/Disable Delay

Note (AL× series only): when the device is in standby, the oscillator stops. When standby is released, the oscillator starts and stable oscillator output occurs after a short delay.

Please pay your attention to the following points at time of using the products shown in this document.

The products shown in this document (hereinafter "Products") are not intended to be used for the apparatus that exerts harmful influence on human lives due to the defects, failure or malfunction of the Products. Customers are requested to obtain prior written agreement for such use from SEIKO NPC CORPORATION (hereinafter "NPC"). Customers shall be solely responsible for, and indemnify and hold NPC free and harmless from, any and all claims, damages, losses, expenses or lawsuits, due to such use without such agreement. NPC reserves the right to change the specifications of the Products in order to improve the characteristic or reliability thereof. NPC makes no claim or warranty that the contents described in this document dose not infringe any intellectual property right or other similar right owned by third parties. Therefore, NPC shall not be responsible for such problems, even if the use is in accordance with the descriptions provided in this document. Any descriptions including applications, circuits, and the parameters of the Products in this document are for reference to use the Products, and shall not be guaranteed free from defect, inapplicability to the design for the mass-production products without further testing or modification. Customers are requested not to export or re-export, directly or indirectly, the Products to any country or any entity not in compliance with or in violation of the national export administration laws, treaties, orders and regulations. Customers are requested appropriately take steps to obtain required permissions or approvals from appropriate government agencies.

The logo for NPC (Seiko NPC Corporation) consists of the letters 'NPC' in a bold, stylized, sans-serif font. The 'N' and 'P' are connected at the top, and the 'C' is a simple, rounded shape.

SEIKO NPC CORPORATION

15-6, Nihombashi-kabutocho, Chuo-ku,
Tokyo 103-0026, Japan
Telephone: +81-3-6667-6601
Facsimile: +81-3-6667-6611
<http://www.npc.co.jp/>
Email: sales@npc.co.jp

NC9801LE 2008.01