

OVERVIEW

The SM5306A is a 3-channel low-voltage video buffer IC that can drive a 75Ω termination resistance load. The output buffer gain can be switched between 0dB and 6dB. A built-in sag compensation circuit enables a lower output coupling capacitance to be used. The device operates from a 3.0 to 5.5V supply.

FEATURES

- Supply voltage: 3.0 to 5.5V
- Current consumption: 24mA ($V_{CC} = 3.3V$)
- Output gain switching: 0dB (GSEL = LOW)
6dB (GSEL = HIGH)
- Gain error: $\pm 0.5dB$
- Maximum passband frequency: over 20MHz
- Maximum output voltage: min. 2.0Vp-p
(gain = 6dB)
- Sag compensation circuit built-in
- Sync tip clamp input
- Operating ambient temperature range: 0 to 70°C
- Package: 16-pin VSOP (Pb free)

APPLICATIONS

- LCD monitor

ORDERING INFORMATION

Device	Package
SM5306AV	16-pin VSOP

PINOUT

(Top view)

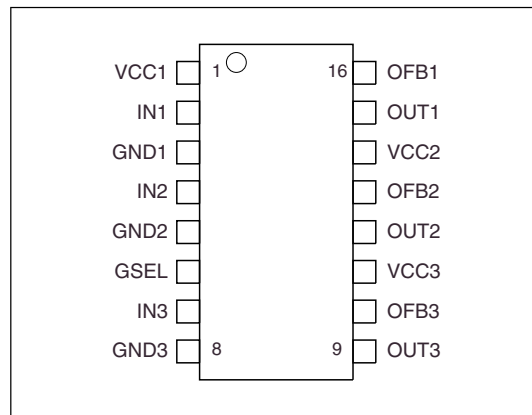

PACKAGE DIMENSIONS

(Unit: mm)

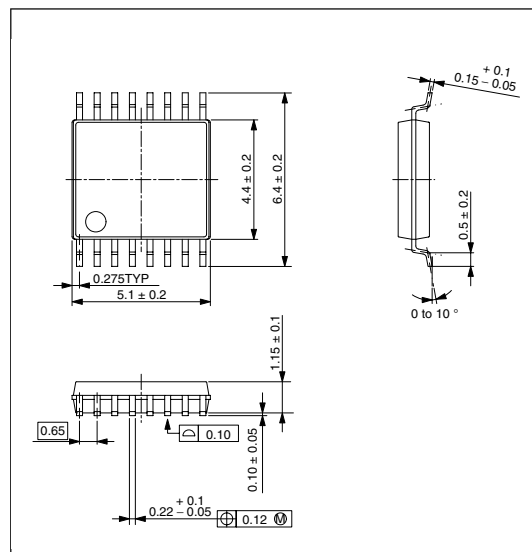

BLOCK DIAGRAM

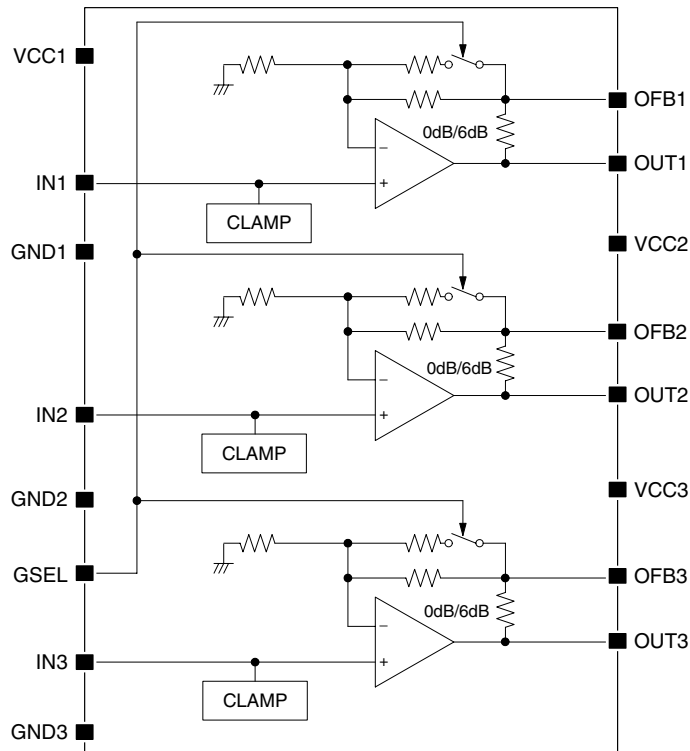

PIN DESCRIPTION

Number	Name	I/O ¹	Description
1	VCC1	-	Supply voltage 1
2	IN1	I	Video signal input 1
3	GND1	-	Ground 1
4	IN2	I	Video signal input 2
5	GND2	-	Ground 2
6	GSEL	I	Gain select (LOW: 0dB, HIGH: +6dB)
7	IN3	I	Video signal input 3
8	GND3	-	Ground 3
9	OUT3	O	Video signal output 3
10	OFB3	O	Output feedback 3 (for sag compensation circuit)
11	VCC3	-	Supply voltage 3
12	OUT2	O	Video signal output 2
13	OFB2	O	Output feedback 2 (for sag compensation circuit)
14	VCC2	-	Supply voltage 2
15	OUT1	O	Video signal output 1
16	OFB1	O	Output feedback 1 (for sag compensation circuit)

1. I: input, O: output

PIN EQUIVALENT CIRCUIT

Number	Name	Equivalent circuit
<p>2 4 7</p>	<p>IN1 IN2 IN3</p>	
<p>6</p>	<p>GSEL</p>	
<p>16 13 10 15 12 9</p>	<p>OFB1 OFB2 OFB3 OUT1 OUT2 OUT3</p>	

SPECIFICATIONS

Absolute Maximum Ratings

$V_{CC1} = V_{CC2} = V_{CC3} = V_{CC}$, GND = 0V, unless otherwise noted

Parameter	Symbol	Condition	Rating	Unit
Supply voltage range	V_{CC}		- 0.3 to 7.0	V
Input voltage range	V_{IN}	GSEL pin	GND - 0.3 to $V_{CC} + 0.3$	V
Storage temperature range	T_{STG}		- 55 to + 125	°C
Power dissipation	P_D		250	mW

Recommended Operating Conditions

Parameter	Symbol	Condition	Rating	Unit
Supply voltage	V_{CC}		3.0 to 5.5	V
Operating ambient temperature range	T_a		0 to 70	°C

DC Characteristics (GSEL)

$V_{CC} = 3.0$ to 5.5 V, $T_a = 0$ to 70 °C, unless otherwise noted

Parameter	Symbol	Condition	Rating			Unit
			min	typ	max	
HIGH-level input voltage	V_{IH}		$V_{CC} - 0.5$	-	-	V
LOW-level input voltage	V_{IL}		-	-	0.5	V
Input leakage current	I_{LL}	$V_{IN} = 0V$	-	-	1	μA
	I_{LH}	$V_{IN} = V_{CC}$	-	-	1	μA

Analog Characteristics

$V_{CC} = 3.3$ V, $T_a = 25$ °C, $R_L = 150$ Ω, $f_{in} = 100$ kHz, $V_{IN} = 1.0$ Vp-p, unless otherwise noted

See "Measurement Circuit Diagram"

Parameter	Symbol	Condition	Rating			Unit
			min	typ	max	
Current consumption 1	I_{CC1}	Gain = 6dB, no signal input	-	24	30	mA
Current consumption 2	I_{CC2}	$V_{CC} = 5.5$ V, Gain = 6dB, no signal input	-	26	35	mA
Output gain 1	A_{V1}	Gain = 0dB	- 0.5	0	0.5	dB
Output gain 2	A_{V2}	Gain = 6dB	5.5	6.0	6.5	dB
Channel gain error	dA_V	Gain = 0dB, 6dB	-	-	± 0.3	dB
Channel crosstalk	C_T	Gain = 6dB, ratio with $V_{OUT} = 2$ Vp-p	-	- 65	-	dB
Maximum passband frequency 1	F_{PB1}	-1dB, gain = 0dB	20	49	-	MHz
Maximum passband frequency 2	F_{PB2}	-1dB, gain = 6dB	20	23	-	MHz
Input voltage	V_{AIN1}	AC-coupled input, Gain = 0dB, 6dB	-	-	1.0	Vp-p
Maximum output voltage 1	V_{OUT1}	Gain = 0dB, THD = 1%	1.0	-	-	Vp-p
Maximum output voltage 2	V_{OUT2}	Gain = 6dB, THD = 1%	2.0	-	-	Vp-p
Input clamp voltage	V_{CLMP}	No signal input	1.15	1.35	1.55	V
Output distortion ratio	T_{HD}	Gain = 6dB	-	-	1	%

Measurement Circuit Diagram

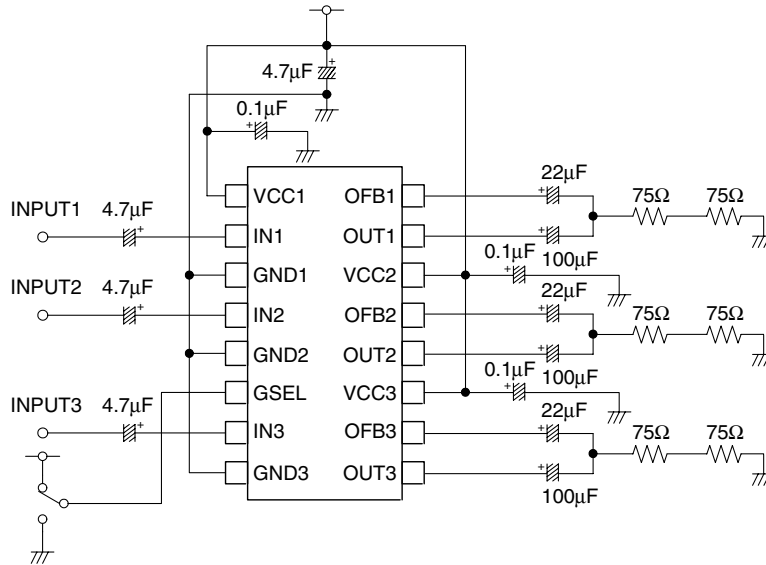

FUNCTIONAL DESCRIPTION

Output Gain Setting (GSEL)

GSEL pin	Output gain
LOW	0dB
HIGH	6dB

TYPICAL APPLICATION CIRCUIT

Application Circuit 1 (standard connection)

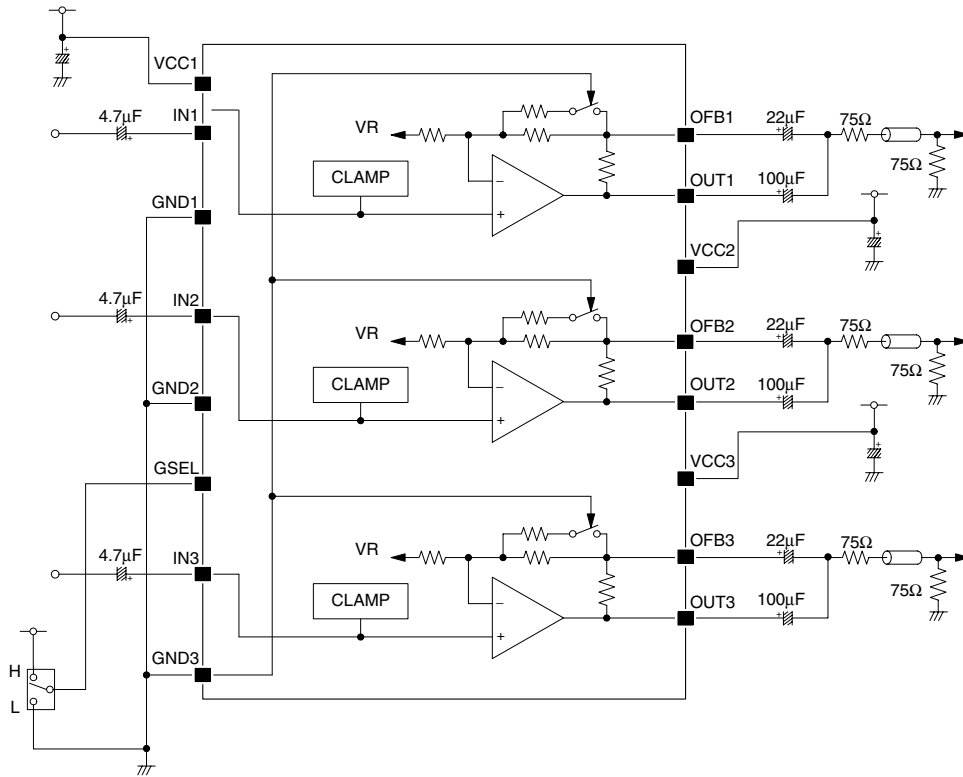

Note. Capacitance does not restrict to this value.

Application Circuit 2 (capacitively-coupled display module connection)

- Capacitor connections to the SM5306A output pins are not required.
- Short circuit OUT \times pins to OFB \times pins. In this mode, the sag compensation circuit does not function.

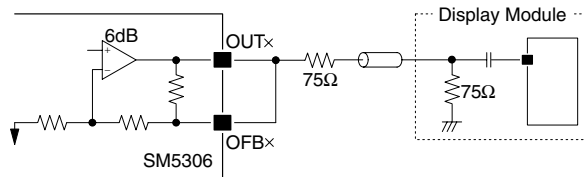

Note. Only output connection is shown.

Application Circuit 3 (input connection to next stage on same printed circuit board)

- A gain of 0dB is suitable, since matching resistors are not required. In this case, it is recommended that a 1k Ω resistor be connected to ground.

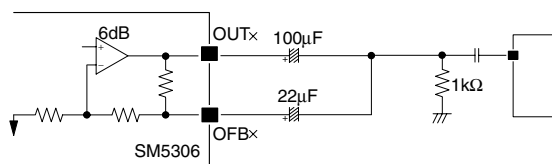

Note. Only output connection is shown.

TYPICAL CHARACTERISTICS

$V_{CC} = 3.3V$, $T_a = 25^{\circ}C$, $R_L = 150\Omega$, $f_{in} = 100kHz$, $V_{IN} = 1.0V_{p-p}$, unless otherwise noted
See "Measurement Circuit Diagram"

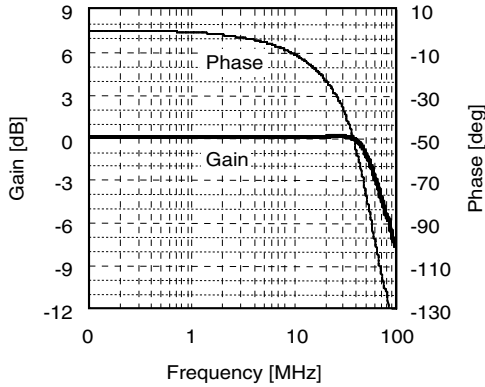

Figure 1. Frequency response (Gain = 0dB)

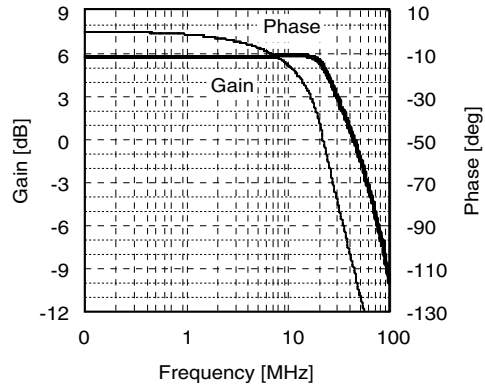

Figure 2. Frequency response (Gain = 6dB)

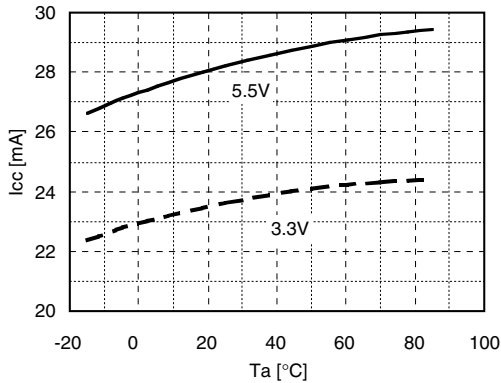

Figure 3. I_{CC} vs. T_a (no signal input)

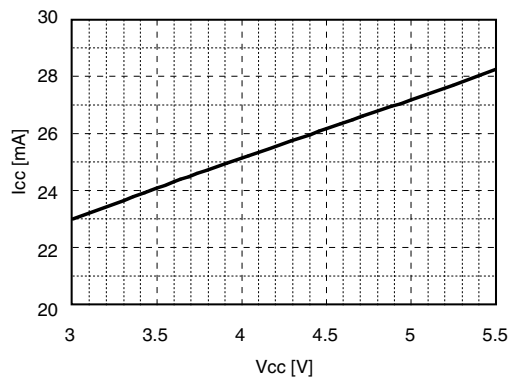

Figure 4. I_{CC} vs. V_{CC} (no signal input)

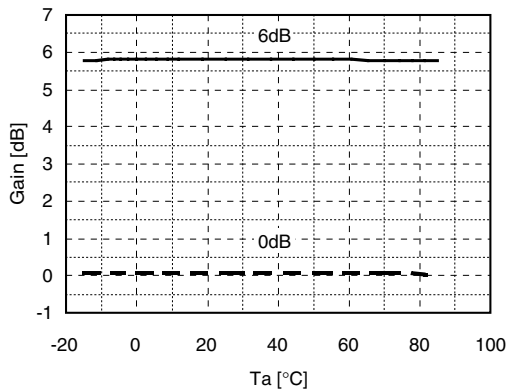

Figure 5. Gain vs. T_a

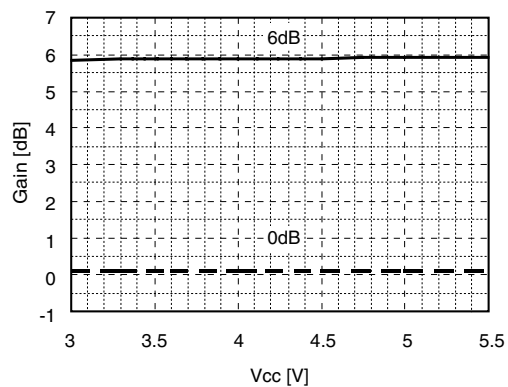

Figure 6. Gain vs. V_{CC}

Please pay your attention to the following points at time of using the products shown in this document.

The products shown in this document (hereinafter "Products") are not intended to be used for the apparatus that exerts harmful influence on human lives due to the defects, failure or malfunction of the Products. Customers are requested to obtain prior written agreement for such use from SEIKO NPC CORPORATION (hereinafter "NPC"). Customers shall be solely responsible for, and indemnify and hold NPC free and harmless from, any and all claims, damages, losses, expenses or lawsuits, due to such use without such agreement. NPC reserves the right to change the specifications of the Products in order to improve the characteristic or reliability thereof. NPC makes no claim or warranty that the contents described in this document dose not infringe any intellectual property right or other similar right owned by third parties. Therefore, NPC shall not be responsible for such problems, even if the use is in accordance with the descriptions provided in this document. Any descriptions including applications, circuits, and the parameters of the Products in this document are for reference to use the Products, and shall not be guaranteed free from defect, inapplicability to the design for the mass-production products without further testing or modification. Customers are requested not to export or re-export, directly or indirectly, the Products to any country or any entity not in compliance with or in violation of the national export administration laws, treaties, orders and regulations. Customers are requested appropriately take steps to obtain required permissions or approvals from appropriate government agencies.

The logo for NPC (Seiko NPC Corporation) consists of the letters 'NPC' in a bold, stylized, sans-serif font. The 'N' and 'P' are connected at the top, and the 'C' is a simple, rounded shape.

SEIKO NPC CORPORATION

15-6, Nihombashi-kabutocho, Chuo-ku,
Tokyo 103-0026, Japan
Telephone: +81-3-6667-6601
Facsimile: +81-3-6667-6611
<http://www.npc.co.jp/>
Email: sales@npc.co.jp

NC0307BE 2006.04