



MMDT227A

COMPLEMENTARY NPN / PNP SMALL SIGNAL SURFACE MOUNT TRANSISTOR

VOLTAGE 60 Volts **POWER** 200 mW

SOT-363 Unit: inch (mm)

FEATURES

- Complementary Pair
- Epitaxial Planar Die Construction
- Ultra-Small Surface Mount Package
- One MMDT222A-Type NPN
One MMDT2907A-Type PNP
- Ideal for Low Power Amplification and Switching
- Also Available in Lead Free Version
- In compliance with EU RoHS 2002/95/EC directives

MECHANICAL DATA

- Case: SOT-363
- Terminals : Solderable per MIL-STD-750D,Method 1036.3
- Approx Weight: 0.006 grams
- Device Marking : S0A

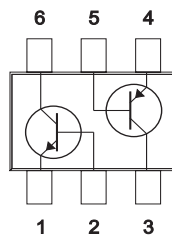
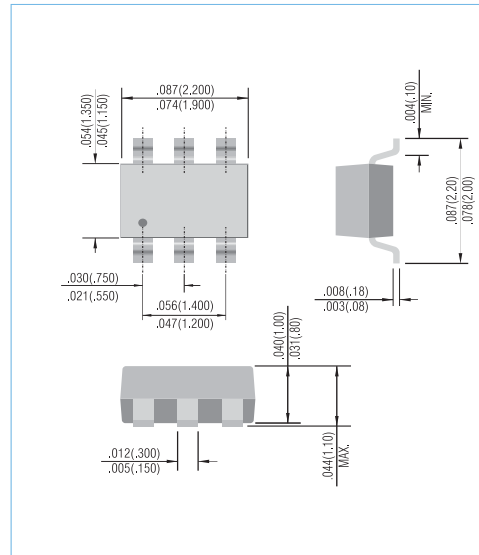

Fig.55

Maximum Ratings MMDT222A Section @ $T_A=25^\circ\text{C}$ unless otherwise specified

Characteristic	Symbol	MMDT222A	Units
Collector-Base Voltage	V_{CBO}	75	V
Collector-Emitter Voltage	V_{CEO}	40	V
Emitter-Base Voltage	V_{EBO}	6.0	V
Collector Current-Continuous	I_C	600	mA
Power Dissipation	P_d	225	mW
Thermal Resistance, Junction to Ambient	$R_{\theta JA}$	625	$^\circ\text{C}/\text{W}$
Operation and Storage and Temperature Range	T_J, T_{STG}	-55 to +150	$^\circ\text{C}$



MMDT2227A

Maximum Ratings MMDT2907A Section @ $T_A=25^\circ\text{C}$ unless otherwise specified

Characteristic	Symbol	MMDT2907A	Units
Collector-Base Voltage	V_{CBO}	-60	V
Collector-Emitter Voltage	V_{CEO}	-60	V
Emitter-Base Voltage	V_{EBO}	-5.0	V
Collector Current-Continuous	I_C	-600	mA
Power Dissipation	P_d	200	mW
Thermal Resistance, Junction to Ambient	$R_{\theta JA}$	625	$^\circ\text{C/W}$
Operation and Storage and Temperature Range	T_J, T_{STG}	-55 to +150	$^\circ\text{C}$



MMDT227A

Electrical Characteristics, MMDT222A Section @ $T_A=25^\circ\text{C}$ unless otherwise specified

Characteristic	Symbol	Min.	Max.	Unit	Test Condition
OFF CHARACTERISTICS(Note 2)					
Collector-Base Breakdown Voltage	$V_{(BR)CBO}$	75	-	V	$I_C=-10\mu\text{A}, I_E=0$
Collector-Emitter Breakdown Voltage	$V_{(BR)CEO}$	40	-	V	$I_C=10\text{mA}, I_B=0$
Emitter-Base Breakdown Voltage	$V_{(BR)EBO}$	6.0	-	V	$I_E=-10\mu\text{A}, I_C=0$
Collector Cutoff Current	I_{CBO}	-	10	nA μA	$V_{CB}=60\text{V}, I_E=0$ $V_{CB}=60\text{V}, I_E=0, T_A=150^\circ\text{C}$
Collector Cutoff Current	I_{CEX}	-	10	nA	$V_{CE}=60\text{V}, V_{EB(OFF)}=3.0\text{V}$
Emitter Cutoff Current	I_{EBO}	-	100	nA	$V_{EB}=3.0\text{V}, I_C=0$
Base Cutoff Current	I_{BL}	-	20	nA	$V_{CE}=60\text{V}, V_{EB(OFF)}=3.0\text{V}$
ON CHARACTERISTICS(Note 2)					
DC Current Gain	h_{FE}	35 50 75 100 40 50 50	- - - 300 - - -	-	$I_C=100\mu\text{A}, V_{CE}=10\text{V}$ $I_C=1.0\text{mA}, V_{CE}=10\text{V}$ $I_C=10\text{mA}, V_{CE}=10\text{V}$ $I_C=150\text{mA}, V_{CE}=10\text{V}$ $I_C=500\text{mA}, V_{CE}=10\text{V}$ $I_C=10\text{mA}, V_{CE}=10\text{V}, T_A=-55^\circ\text{C}$ $I_C=150\text{mA}, V_{CE}=1.0\text{V}$
Collector-Emitter Saturation Voltage	$V_{CE(SAT)}$	- -	0.3 1.0	V	$I_C=150\text{mA}, I_B=15\text{mA}$ $I_C=500\text{mA}, I_B=50\text{mA}$
Base-Emitter Saturation Voltage	$V_{BE(SAT)}$	0.6 -	1.2 2.0	V	$I_C=150\text{mA}, I_B=15\text{mA}$ $I_C=500\text{mA}, I_B=50\text{mA}$
SMALL SIGNAL CHARACTERISTICS					
Output Capacitance	C_{obo}	-	8	pF	$V_{CB}=10\text{V}, f=1.0\text{MHz}, I_E=0$
Input Capacitance	C_{ibo}	-	25	pF	$V_{EB}=0.5\text{V}, f=1.0\text{MHz}, I_C=0$
Current Gain-Bandwidth Product	f_T	300	-	MHz	$V_{CE}=20\text{V}, I_C=20\text{mA}$, $f=100\text{MHz}$
Noise Figure	NF	-	4.0	dB	$V_{CE}=10\text{V}, I_C=100\mu\text{A}$, $R_S=1.0\text{k}\Omega, f=1.0\text{kHz}$
SWITCHING CHARACTERISTICS					
Delay Time	t_d	-	10	ns	$V_{CC}=30\text{V}, I_C=150\text{mA}$, $V_{BE(OFF)}=-0.5\text{V}, I_{B1}=15\text{mA}$
Rise Time	t_r	-	25	ns	



MMDT2227A

Electrical Characteristics, MMDT2907A Section @ $T_A=25^\circ\text{C}$ unless otherwise specified

Characteristic	Symbol	Min.	Max.	Unit	Test Condition
OFF CHARACTERISTICS(Note 2)					
Collector-Base Breakdown Voltage	$V_{(BR)}CBO$	-60	-	V	$I_C=-10\mu\text{A}, I_E=0$
Collector-Emitter Breakdown Voltage	$V_{(BR)}CEO$	-60	-	V	$I_C=-10\text{mA}, I_B=0$
Emitter-Base Breakdown Voltage	$V_{(BR)}EBO$	-5.0	-	V	$I_E=-10\mu\text{A}, I_C=0$
Collector Cutoff Current	I_{CBO}	-	-10	nA μA	$V_{CE}=-50\text{V}, I_E=0$ $V_{CB}=-50\text{V}, I_E=0, T_A=125^\circ\text{C}$
Collector Cutoff Current	I_{CEX}	-	-50	nA	$V_{CE}=-30\text{V}, V_{EB(OFF)}=-0.5\text{V}$
Base Cutoff Current	I_{BL}	-	-50	nA	$V_{CE}=-30\text{V}, V_{EB(OFF)}=-0.5\text{V}$
ON CHARACTERISTICS(Note 2)					
DC Current Gain	h_{FE}	75 100 100 100 50	- - - 300 -	-	$I_C=-100\mu\text{A}, V_{CE}=-10\text{V}$ $I_C=-1.0\text{mA}, V_{CE}=-10\text{V}$ $I_C=-10\text{mA}, V_{CE}=-10\text{V}$ $I_C=-150\text{mA}, V_{CE}=-10\text{V}$ $I_C=-500\text{mA}, V_{CE}=-10\text{V}$
Collector-Emitter Saturation Voltage	$V_{CE(SAT)}$	-	-0.4 -1.6	V	$I_C=-150\text{mA}, I_B=-15\text{mA}$ $I_C=-500\text{mA}, I_B=-50\text{mA}$
Base-Emitter Saturation Voltage	$V_{BE(SAT)}$	-	-1.3 -2.6	V	$I_C=-150\text{mA}, I_B=-15\text{mA}$ $I_C=-500\text{mA}, I_B=-50\text{mA}$
SMALL SIGNAL CHARACTERISTICS					
Output Capacitance	C_{obo}	-	8	pF	$V_{CB}=-10\text{V}, f=1.0\text{MHz}, I_E=0$
Input Capacitance	C_{ibo}	-	30	pF	$V_{EB}=-2.0\text{V}, f=1.0\text{MHz}, I_C=0$
Current Gain-Bandwidth Product	f_T	200	-	MHz	$V_{CE}=-20\text{V}, I_C=-50\text{mA}$, $f=100\text{MHz}$
SWITCHING CHARACTERISTICS					
Turn-On Time	t_{on}	-	45	ns	$I_C=-150\text{mA}, V_{CC}=-30\text{V}$, $I_{B1}=-15\text{mA}$
Delay Time	t_d	-	10	ns	$V_{CC}=-30\text{V}, I_C=-150\text{mA}$, $I_{B1}=-15\text{mA}$
Rise Time	t_r	-	40	ns	



MMDT2227A

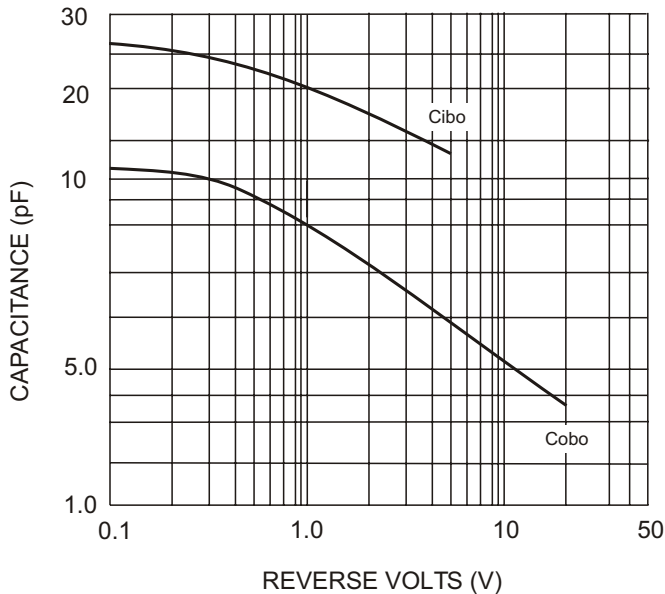

Fig. 1 (2222A) Typical Capacitance

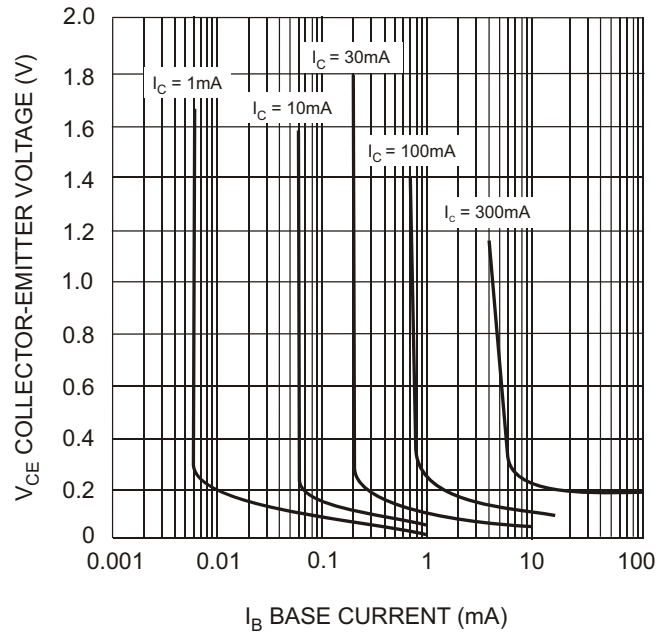

Fig. 2 (2222A) Typical Collector Saturation Region

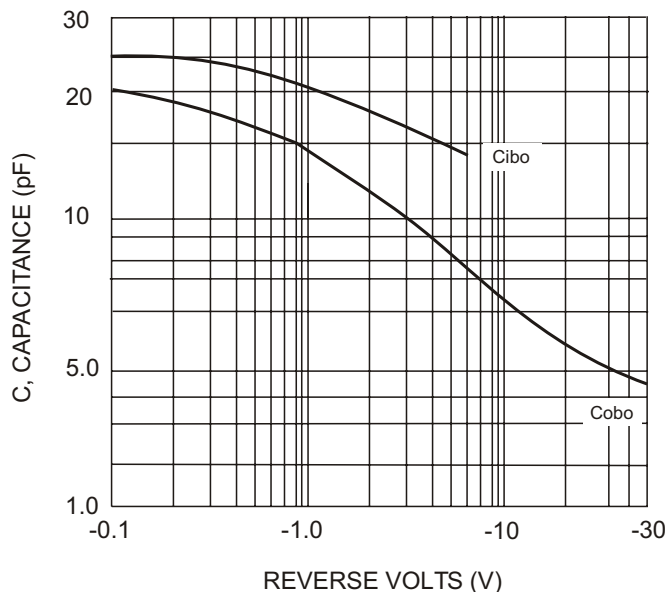

Fig. 3 (2907A) Typical Capacitance

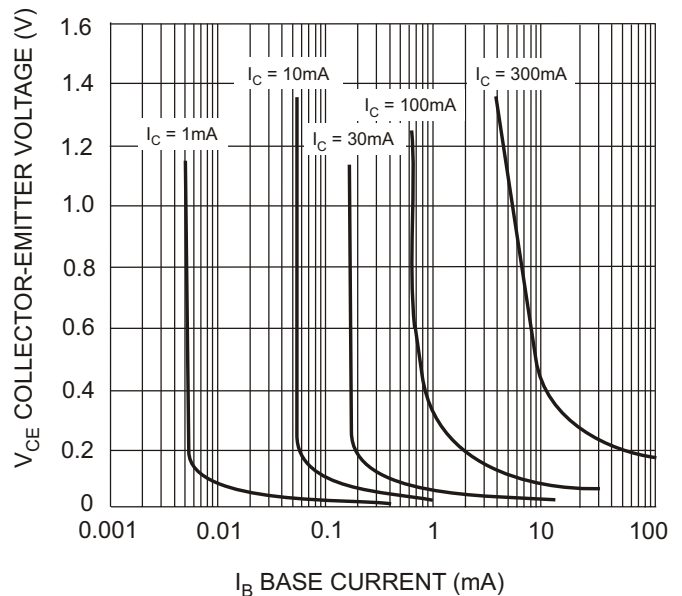
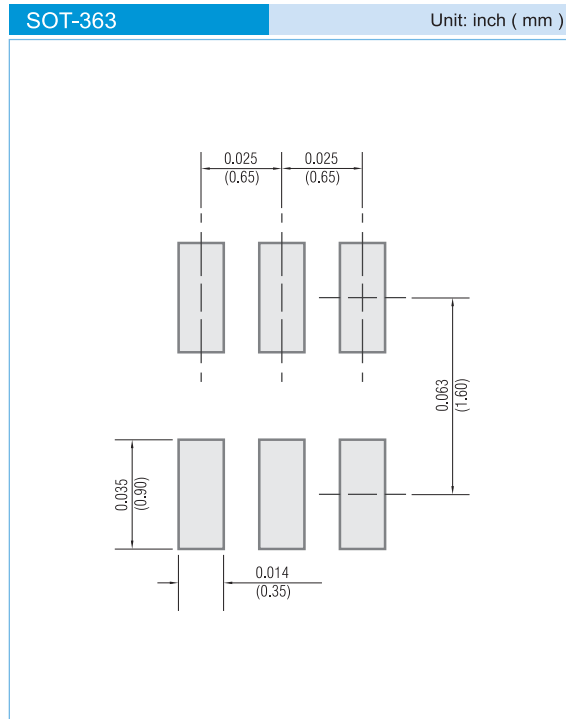

Fig. 4 (2907A) Typical Collector Saturation Region



MMDT2227A

MOUNTING PAD LAYOUT



ORDER INFORMATION

- Packing information
 - T/R - 10K per 13" plastic Reel
 - T/R - 3K per 7" plastic Reel

LEGAL STATEMENT

Copyright PanJit International, Inc 2007

The information presented in this document is believed to be accurate and reliable. The specifications and information herein are subject to change without notice. Pan Jit makes no warranty, representation or guarantee regarding the suitability of its products for any particular purpose. Pan Jit products are not authorized for use in life support devices or systems. Pan Jit does not convey any license under its patent rights or rights of others.