

1A Low Dropout Regulator with Enable

FEATURES

- Adjustable output from 1.2V to 4.8V
- Output voltage options 1.5V, 1.8V and 2.5V (externally adjustable using resistors)
- Over-current and over-temperature protection
- Dropout voltage of 400mV at 1A load
- Enable pin
- Quiescent current of 10µA in shutdown
- SOT-89-5 Package

APPLICATIONS

- Battery-powered systems
- Motherboards
- Peripheral cards
- Network cards
- Set Top Boxes
- Medical Equipment
- Notebook Computers

DESCRIPTION

The SS8061 is a high performance positive voltage regulator designed for use in applications requiring very low dropout voltage at up to 1 Amps. Since it has superior dropout characteristics compared to regular LDOs, it can be used to supply 2.5V on motherboards or 1.5V, 1.8V on peripheral cards from the 3.3V supply thus allowing the elimination of costly heatsinks. An enable-pin further reduces power dissipation while in shut-down. The SS8061 provides excellent regulation over variations in line, load and temperature.

The SS8061 is available with 1.5V, 1.8V and 2.5V internally preset outputs that are also adjustable using external resistors.

ORDERING INFORMATION

SS8061-15GTETR	1.5V output, in SOT89-5 with Pb-free lead finish, shipped on tape and reel.
SS8061-18GTETR	1.8V output, in SOT89-5 with Pb-free lead finish, shipped on tape and reel.
SS8061-25GTETR	2.5V output, in SOT89-5 with Pb-free lead finish, shipped on tape and reel.

 This device is only available with Pb-free lead finish (second-level interconnect).

PIN CONFIGURATION

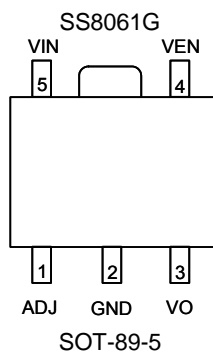

TYPICAL APPLICATION CIRCUIT

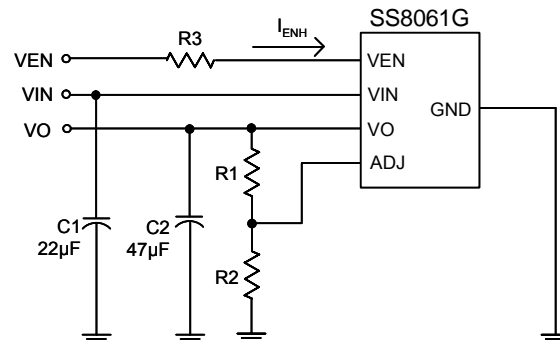

$$VO = \frac{1.2 (R1+R2)}{R2} \text{ Volts}$$

R2=12kΩ is recommended

R3 should be connected for current I_{ENH} restriction as $V_{EN} > V_{IN}+0.3V$

ABSOLUTE MAXIMUM RATINGS

Input Voltage.....	7V
V _{EN} Voltage.....	V _{IN} +0.3V
Power Dissipation Internally Limited (Note 2)	
Maximum Junction Temperature.....	150°C
Storage Temperature Range.....	-65°C ≤ T _J ≤ +150°C
Reflow Temperature (soldering, 10sec).....	260°C
Thermal Resistance Junction to Ambient.....	177°C/W
Thermal Resistance Junction to Case.....	52°C/W
ESD Rating (Human Body Model).....	2kV

OPERATING CONDITIONS (note 1)

Input Voltage.....	2.2V ~5.5V
Temperature Range.....	-40°C ≤ T _A ≤ +85°C

ELECTRICAL CHARACTERISTICS

V_{EN}=V_{IN}, V_{IN} = 5V, I_O = 0.5A, C_{IN} = 4.7μF, C_{OUT} = 10μF, T_A = T_J = 25°C unless otherwise specified (Note 3)

PARAMETER	SYMBOL	CONDITION	MIN	TYP	MAX	UNIT
Supply Voltage	V _{IN}		2.2	---	5.5	V
Output Voltage	V _O	V _{IN} =V _O +0.7V, I _O =10mA	-2	V _O	2	%
Line Regulation		V _O +0.7V ≤ V _{IN} ≤ 5.5V, I _O =10mA	---	0.2	2	%
Load Regulation		10mA ≤ I _O ≤ 1A	---	0.8	2	%
Quiescent Current	I _Q	V _{IN} =3.3V, V _{EN} =V _{IN}	---	1.7	2.5	mA
		V _{IN} =3.3V, V _{EN} =0V	---	16	35	μA
Ripple Rejection		fi=120Hz, 1V _{P-P} , I _O =100mA	---	55	---	dB
Dropout Voltage	V _D	I _O =1A	---	0.4	0.6	V
Short Circuit Current			---	0.8	---	A
Over Temperature			---	150	---	°C
V _{EN} Voltage High	V _{ENH}	Output Active	1.6	---	---	V
V _{EN} Voltage Low	V _{ENL}	Output Disabled	---	---	0.4	V
V _{EN} Bias Current Low	I _{ENL}	V _{EN} =0.4V	---	---	20	μA
ADJ Reference Voltage	V _{REF}	V _{IN} =2.2V, V _{ADJ} =V _{OUT} , I _O =10mA	1.188	1.2	1.212	V
ADJ Pin Threshold			---	0.2	---	V

Note 1: Absolute Maximum Ratings are limits beyond which damage to the device may occur. Operating Conditions are conditions under which the device functions but the specifications might not be guaranteed. For guaranteed specifications and test conditions see the Electrical Characteristics.

Note2: The maximum power dissipation is a function of the maximum junction temperature, T_{Jmax}; total thermal resistance, θ_{JA}, and ambient temperature T_A. The maximum allowable power dissipation at any ambient temperature is (T_{Jmax}-T_A) / θ_{JA}. If this dissipation is exceeded, the die temperature will rise above 150°C and IC will go into thermal shutdown.

Note3: Low duty pulse techniques are used during test to maintain junction temperature as close to ambient as possible.

Note4: The type of output capacitor should be tantalum or aluminum.

Definitions

Dropout Voltage

The input/output Voltage differential at which the regulator output no longer maintains regulation against further reductions in input voltage. Measured when the output drops 2% below its nominal value, dropout voltage is affected by junction temperature, load current and minimum input supply requirements.

Line Regulation

The change in output voltage for a change in input voltage. The measurement is made under conditions of low dissipation or by using pulse techniques such that average chip temperature is not significantly affected.

Load Regulation

The change in output voltage for a change in load current at constant chip temperature. The measurement is made under conditions of low dissipation or by using pulse techniques such that average chip temperature is not significantly affected.

Maximum Power Dissipation

The maximum total device dissipation for which the regulator will operate within specifications.

Quiescent Bias Current

Current which is used to operate the regulator chip and is not delivered to the load.

TYPICAL PERFORMANCE CHARACTERISTICS

$V_{EN}=V_{IN}$, $V_{IN}=5V$, $I_O=0.5A$, $C_{IN}=4.7\mu F$, $C_{OUT}=10\mu F$, $T_A=T_J=25^\circ C$
 ($V_{OUT}=1.8V$)

Line Transient Response

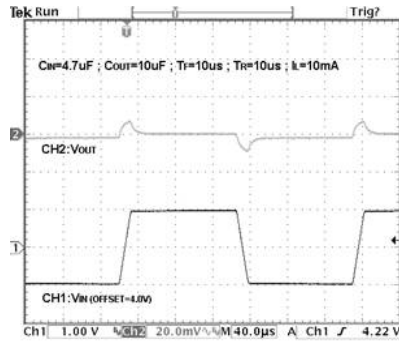

Load Transient Response

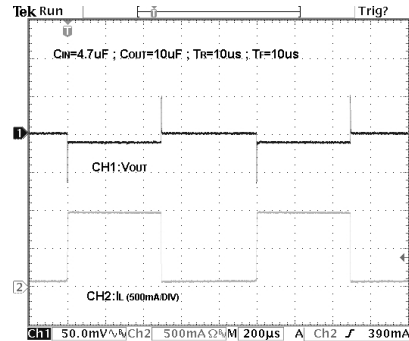

Short Circuit Current

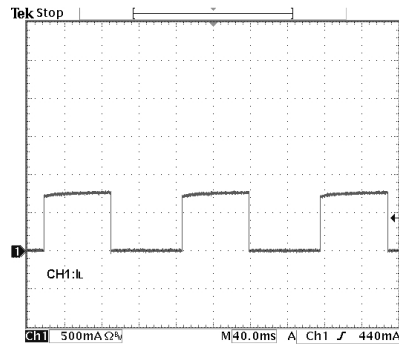

Ripple Rejection

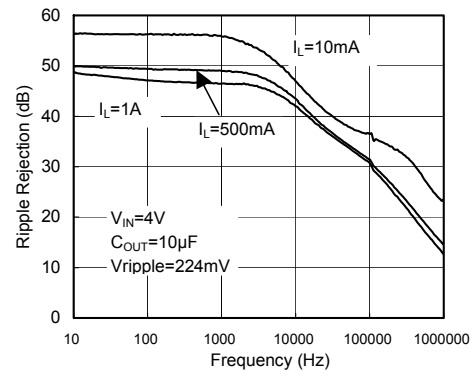

Overcurrent Protection Characteristics

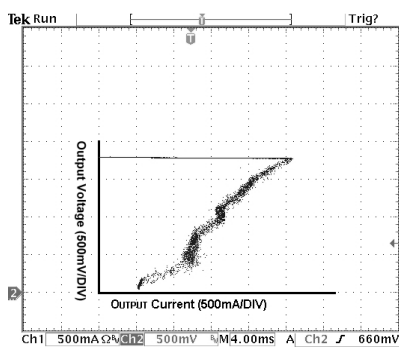

Start-up

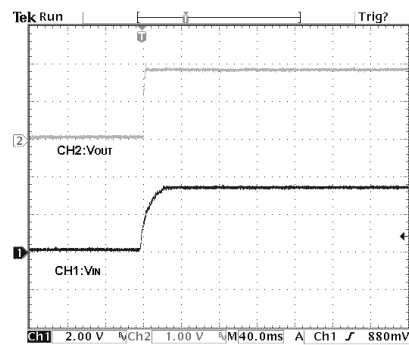

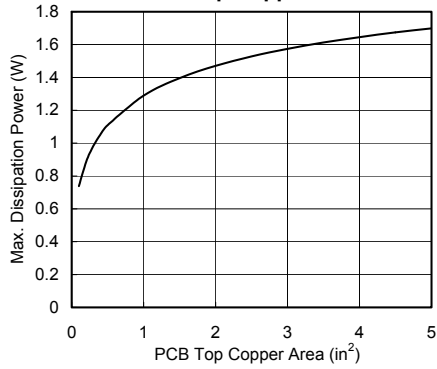
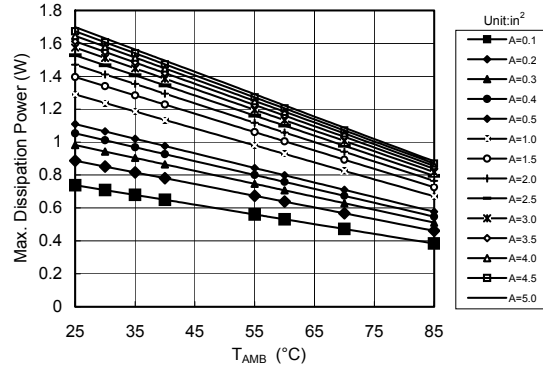
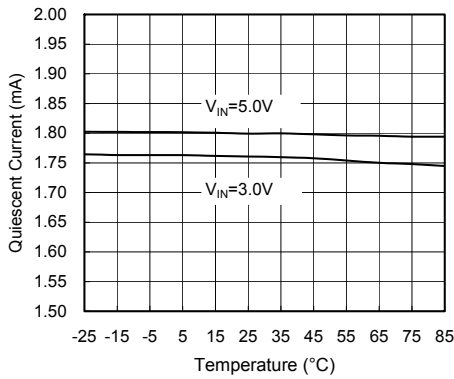
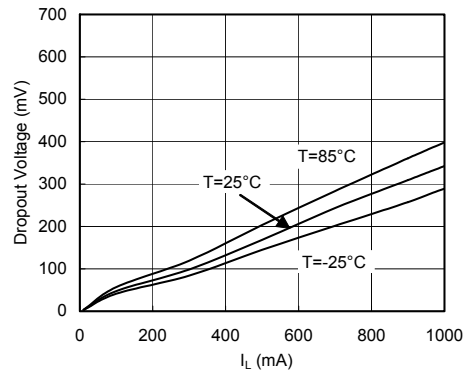
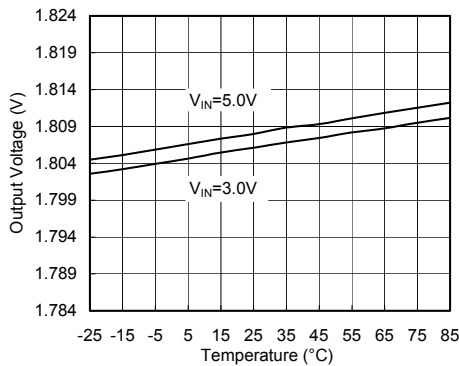
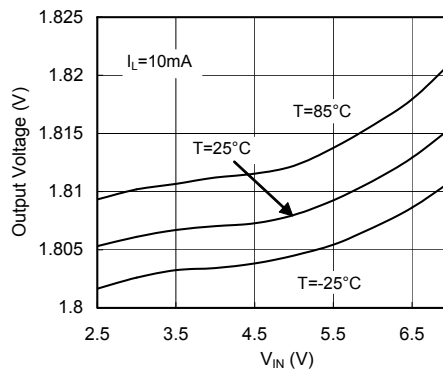
TYPICAL PERFORMANCE CHARACTERISTICS (continued)
Max. Power Dissipation vs. PCB Top Copper Area

Max. Power Dissipation vs. T_{AMB}

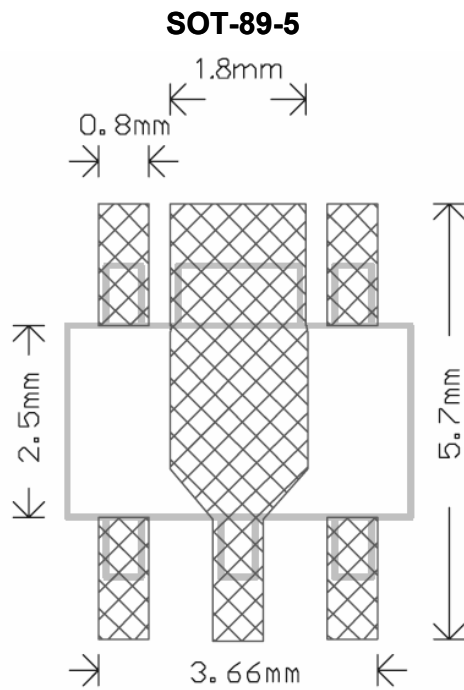
Quiescent Current vs. Temperature

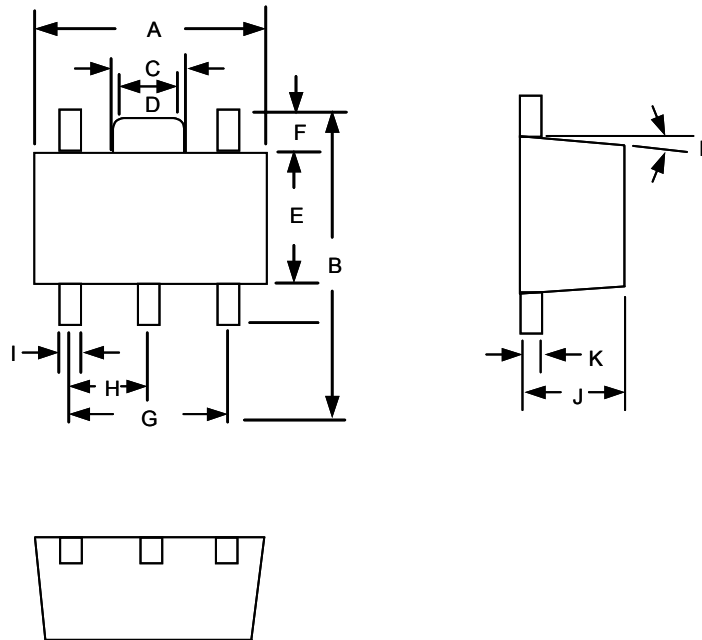
Dropout Voltage vs. I_L

Output Voltage vs. Temperature

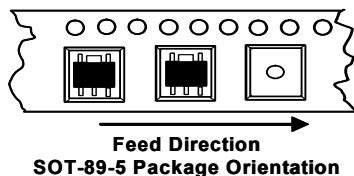
Output Voltage vs. V_{IN}

RECOMMENDED MINIMUM FOOTPRINT



PHYSICAL DIMENSIONS
SOT-89-5

SYMBOL	DIMENSION IN MM		DIMENSION IN INCH	
	MIN	MAX	MIN	MAX
A	4.40	4.60	0.173	0.181
B	4.05	4.25	0.159	0.167
C	1.50	1.70	0.059	0.067
D	1.30	1.50	0.051	0.059
E	2.40	2.60	0.094	0.102
F	0.80	-----	0.031	-----
G	3.00 REF		0.118 REF	
H	1.50 REF		0.059 REF	
I	0.40	0.52	0.016	0.020
J	1.40	1.60	0.055	0.063
K	0.35	0.41	0.014	0.016
L	5° TYP		5° TYP	

Taping Specification

PACKAGE	Q'TY/REEL
SOT-89-5	1,000 ea

Information furnished by Silicon Standard Corporation is believed to be accurate and reliable. However, Silicon Standard Corporation makes no guarantee or warranty, express or implied, as to the reliability, accuracy, timeliness or completeness of such information and assumes no responsibility for its use, or for infringement of any patent or other intellectual property rights of third parties that may result from its use. Silicon Standard reserves the right to make changes as it deems necessary to any products described herein for any reason, including without limitation enhancement in reliability, functionality or design. No license is granted, whether expressly or by implication, in relation to the use of any products described herein or to the use of any information provided herein, under any patent or other intellectual property rights of Silicon Standard Corporation or any third parties.