

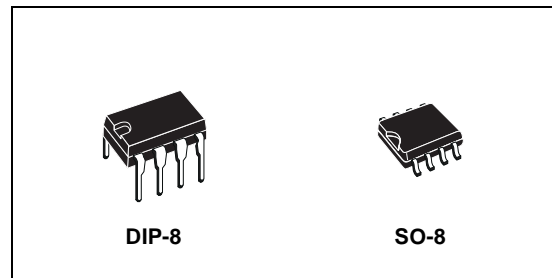

ST735

-5V INVERTING, NEGATIVE OUTPUT CURRENT-MODE PWM REGULATOR

- CONVERTS +4.0V TO + 6.2V INPUT TO -5V OUTPUT
- 1W GUARANTEED OUTPUT POWER
- 75% TYPICAL EFFICIENCY
- 0.8mA QUIESCENT CURRENT
- 10 μ A SHUTDOWN MODE
- 160KHZ FIXED FREQUENCY OSCILLATOR
- CURRENT MODE PWM CONVERTER
- LOW NOISE AND JITTER
- SOFT START
- SIMPLE APPLICATION CIRCUIT
- UNDERVOLTAGE LOCKOUT



These power-conserving features, along with high efficiency and applications circuits, that lend itself to minaturization, make the ST735 excellent in a broad range of on-card, HDD and portable equipment applications. The ST735 employ a high performance current mode pulse with modulation (PWM) control scheme to provide tight output voltage regulation and low noise. The fixed frequency oscillator is factory trimmed to 160KHz, allowing for easy noise filtering. The regulator in production is tested to guarantee an output accuracy within $\pm 5\%$ over all specified conditions.

DESCRIPTION

The ST735 is a Bi-CMOS, inverting switch mode DC-DC regulator with internal Power MOSFET's that generates a fixed -5V output voltage from a 4V to 6.2V input voltage; is guaranteed an output current of 200mA for inputs greater than 4.5V. The quiescent current for this device is typically of 0.8mA and, in shutdown mode it is reduced to 10 μ A.

SCHEMATIC DIAGRAM

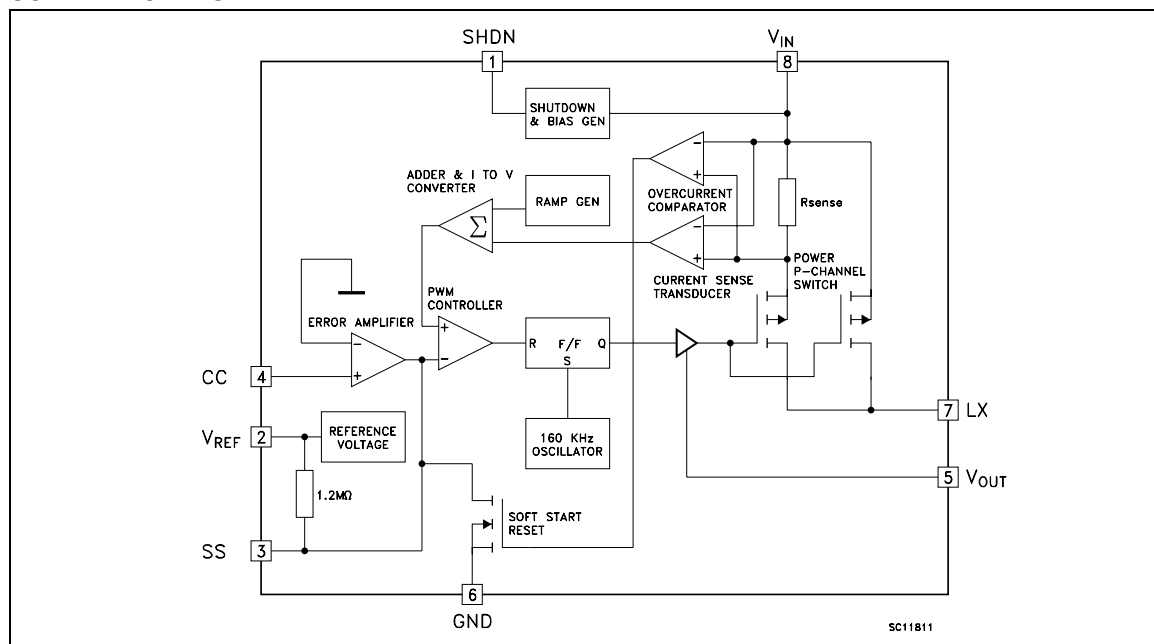

ABSOLUTE MAXIMUM RATINGS

Symbol	Parameter	Value	Unit
V_{IN}	DC Input Voltage (V_{IN} to GND)	-0.3 to +7	V
SHDN	Shutdown Voltage (SHDN to GND)	-0.3 to $V_+ + 0.3$	V
V_{LX}	Switch Voltage (Lx to V_{IN})	-12.5 to +0.3	V
V_{FB}	Feedback Voltage (V_{OUT} to GND)	-11 to +0.3	V
V_{OUT}	Output Voltage (V_{OUT} to GND)	-11 to +0.3	V
	Other Input Voltage (SS, CC to GND)	-0.3 to $V_+ + 0.3$	V
I_{LX}	Peack Switch Current	2	A
P_{tot}	Power Dissipation at $T_j = 70^\circ\text{C}$	DIP-8	725
		SO-8	470
T_{stg}	Storage Temperature Range	-55 to +150	$^\circ\text{C}$
T_{op}	Operating Junction Temperature Range	-40 to +125	$^\circ\text{C}$

Absolute Maximum Ratings are those values beyond which damage to the device may occur. Functional operation under these condition is not implied.

THERMAL DATA

Symbol	Parameter	DIP-8	SO-8	Unit
$R_{thj-case}$	Thermal Resistance Junction-case	2	8	$^\circ\text{C/W}$

CONNECTION DIAGRAM (top view)

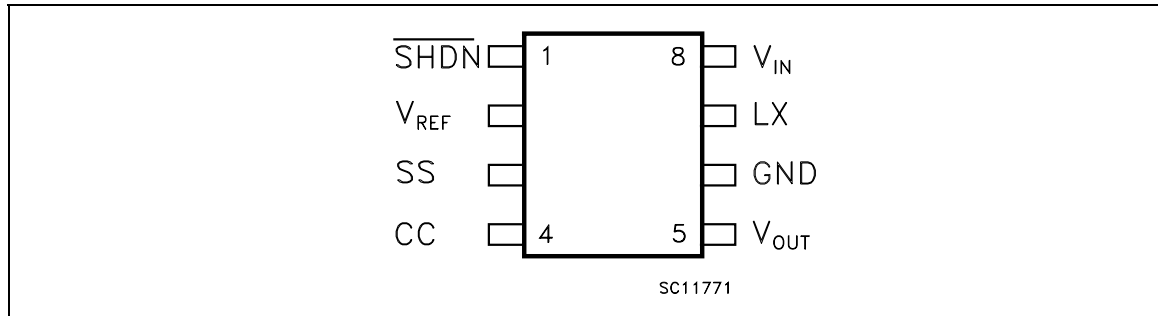

PIN DESCRIPTION

Pin N°	Symbol	Name and Function
1	SHDN	SHUT-DOWN Control ($V_{CC} = \text{ON}$ GND=Shutdown)
2	V_{REF}	Reference Output Voltage
3	SS	Soft Start
4	CC	Compensation Input
5	V_{OUT}	Negative Output Voltage
6	GND	Ground
7	LX	Switch Output
8	V_{IN}	Positive Supply - Voltage Input

ORDERING CODES

TYPE	DIP-8	SO-8	SO-8 (T&R)
ST735	ST735CN	ST735CD	ST735CD-TR

TYPICAL APPLICATION CIRCUIT

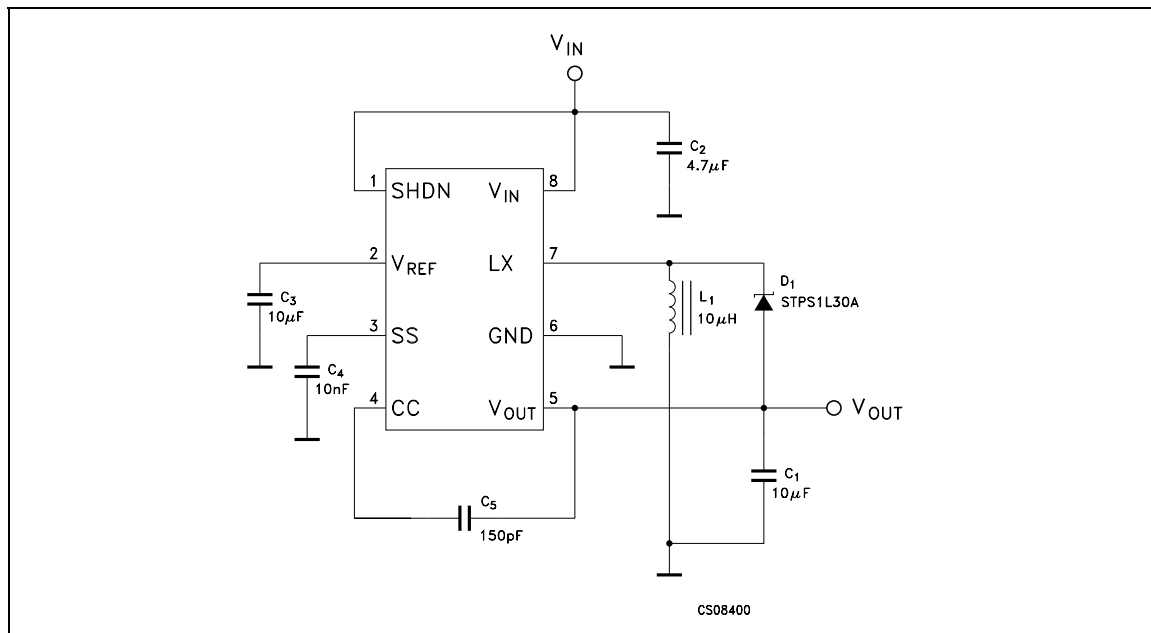

NOTE:

- 1) All capacitors are X7R ceramic
- 2) C_5 can be omitted if are used higher values for the input and output capacitors $C_2=47\mu\text{F}$, $C_1=100\mu\text{F}$.

ELECTRICAL CHARACTERISTICS (Refer to test circuit, $V_{IN}=5V$, $C_{IN} = 4.7\mu F$, $C_{OUT} = 10\mu F$, $L = 10\mu H$, $T_{amb} = -40$ to $125^{\circ}C$, unless otherwise specified. Typical value are referred at $T_{amb}= 25^{\circ}C$)

Symbol	Parameter	Test Conditions	Min.	Typ.	Max.	Unit
V_{IN}	Input Voltage		4		6.2	V
V_{OUT}	Output Voltage	$V_{IN} = 4.5V$ to $6.2V$ $I_{OUT} = 0$ to $200mA$ $T_{amb} = -40$ to $125^{\circ}C$	-5.25	-5	-4.75	V
		$V_{IN} = 4.0V$ to $6.2V$ $I_{OUT} = 0$ to $175mA$ $T_{amb} = -40$ to $125^{\circ}C$	-5.25	-5	-4.75	V
I_{OUT}	Output Current	$V_{IN} = 4.5V$ to $6.2V$ $T_{amb} = 0$ to $125^{\circ}C$	200	275		mA
		$V_{IN} = 4.5V$ to $6.2V$ $I_{OUT} = 0$ to $175mA$ $T_{amb} = -40$ to $125^{\circ}C$	175			mA
		$V_{IN} = 4.0V$ $V_{OUT} = -5V$		175		mA
I_{SUPPLY}	Supply Current	Includes Switch Current		0.8	1.6	mA
$I_{STANDBY}$	Standby Current	$V_{SHDN} = 0V$		1	10	μA
I_{SC}	Short Circuit Current			1.5		A
V_{LO}	Undervoltage Lock-out			3.5	4	V
ΔV_{OUT}	Line Regulation	$V_{IN} = 4.0V$ to $6.2V$		0.1		%/V
ΔV_{OUT}	Load Regulation	$I_{OUT} = 0$ to $200mA$		0.003		%/mA
V_{REF}	Reference Voltage	$T_{amb} = 25^{\circ}C$ (Note 1)		1.247		V
ΔV_{REF}	Reference Drift	$T_{amb} = -40$ to $125^{\circ}C$		50		ppm/ $^{\circ}C$
R_{DSON}	LX ON Voltage			0.5		Ω
I_{LEAK}	LX Leakage Current	$V_{DS} = 10V$		1		μA
I_{SH}	Shutdown Pin Current				1	μA
V_{IL}	Shutdown Input Low Threshold				0.25	V
V_{IH}	Shutdown Input High Threshold		2			V
f_{OSC}	Maximum Oscillator Frequency			160		KHz
η	Efficiency	$I_{OUT} = 100mA$		72		%
R_{CC}	Compensation Pin Impedance on CC Pin			7.5		K Ω

Note1 : Tested at $I_{VREF} = 0mA$

TYPICAL CHARACTERISTICS (Referred to typical application circuit, $T_{amb}=25^{\circ}\text{C}$ unless otherwise specified)

Figure 1 : Output Voltage vs Temperature

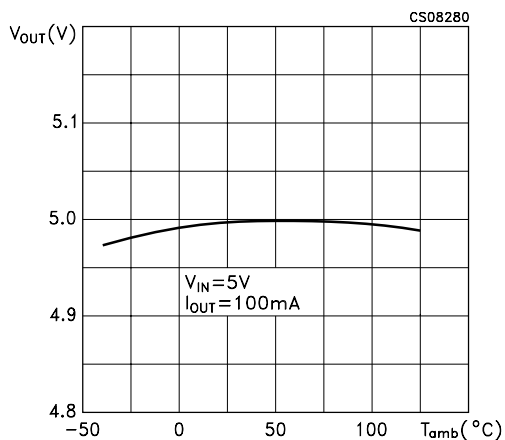

Figure 4 : Efficiency vs Temperature

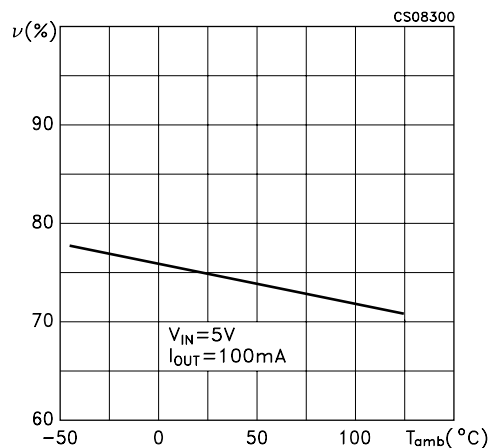

Figure 2 : Reference Voltage vs Temperature

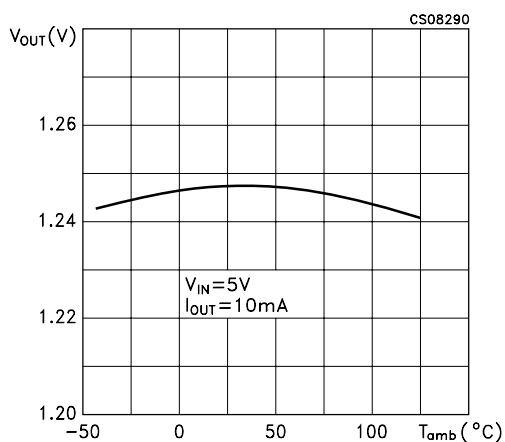

Figure 5 : Efficiency vs Output Current

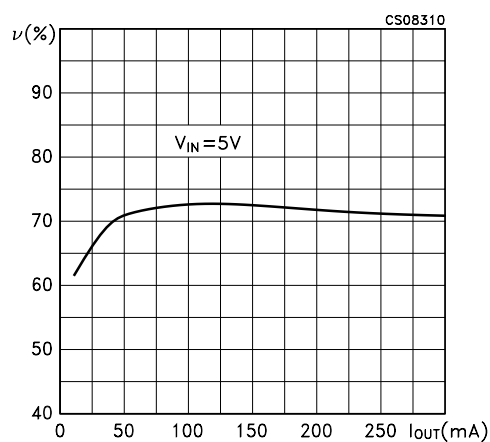

Figure 3 : Oscillator Frequency vs Temperature

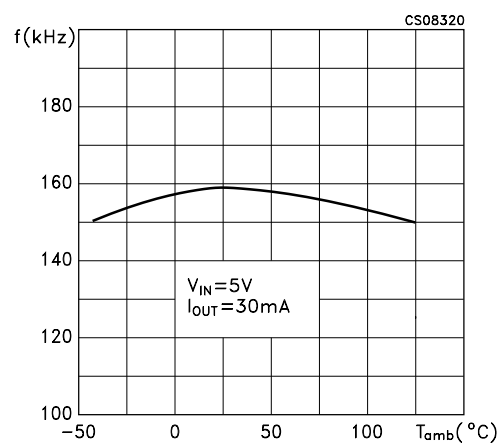

Figure 6 : Supply Current vs Temperature

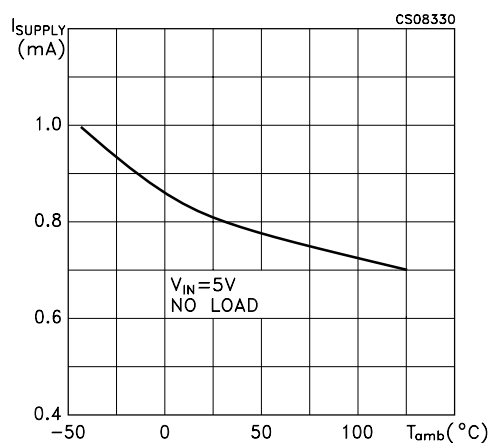

Figure 7 : Supply Current vs Input Voltage

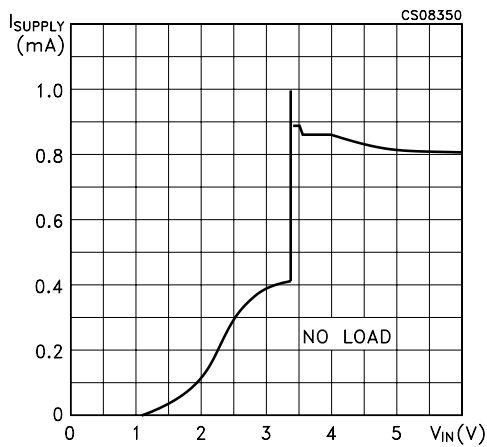

Figure 10 : Switch Current Limit vs Soft Start Voltage

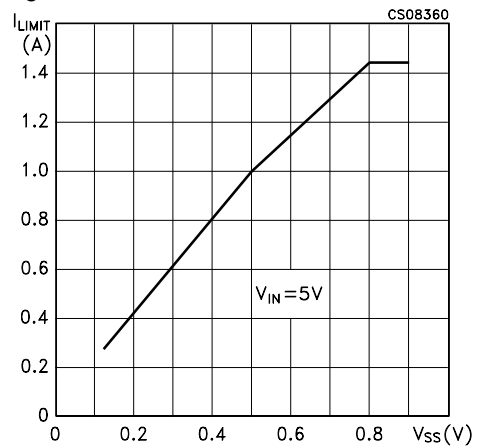

Figure 8 : Shutdown Threshold vs Temperature

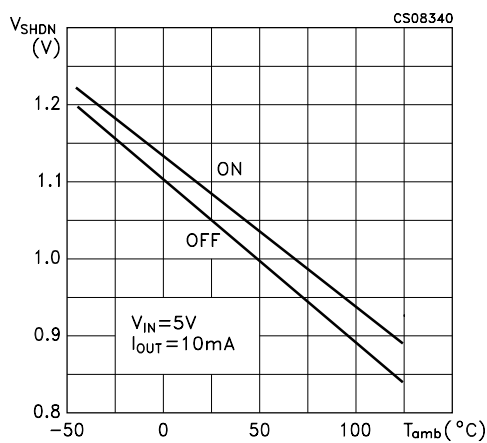

Figure 11 : LX On Resistance vs Temperature

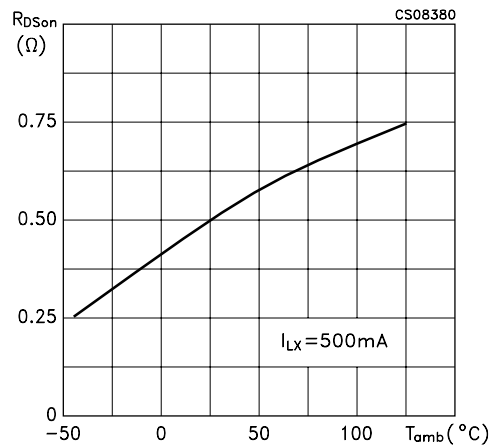

Figure 9 : Peak Inductor Current vs Output Current

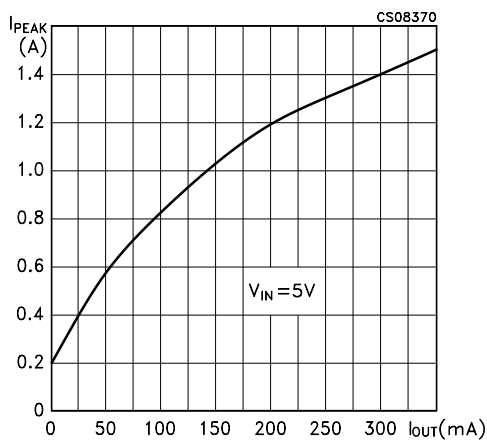
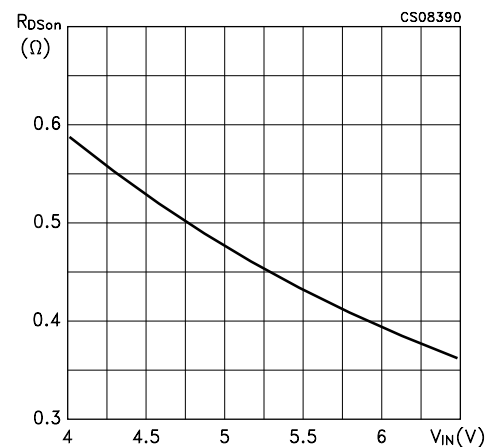
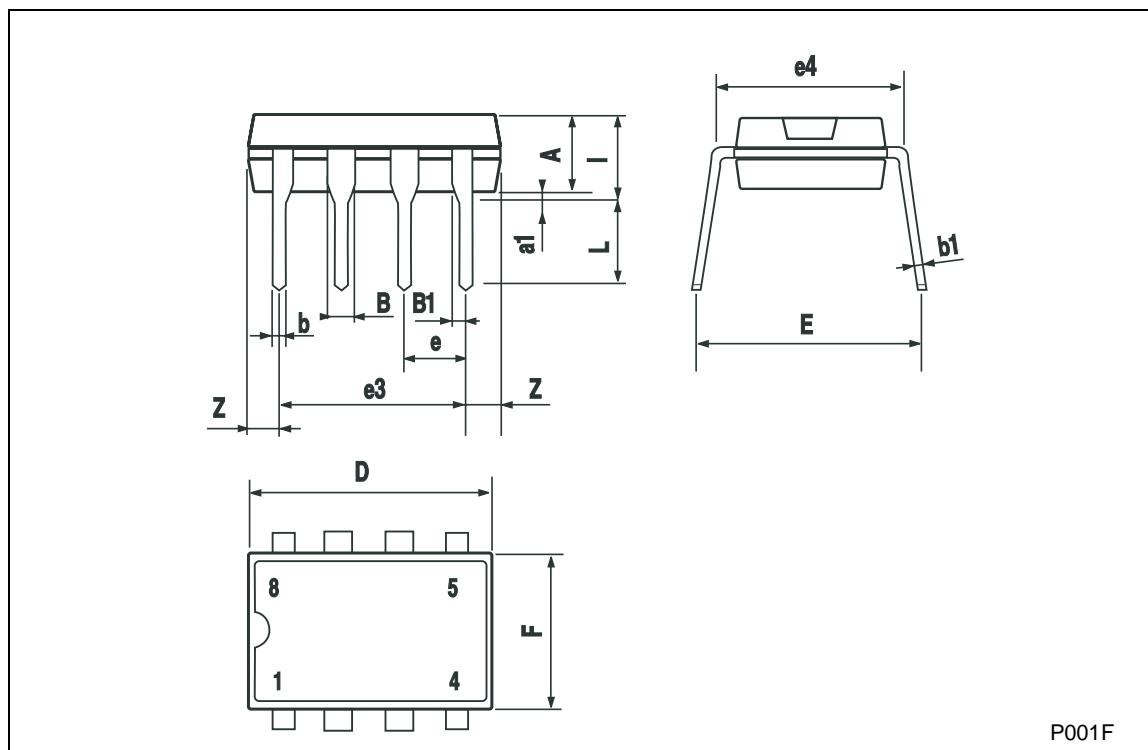

Figure 12 : LX On Resistance vs Input Voltage



Plastic DIP-8 MECHANICAL DATA

DIM.	mm.			inch		
	MIN.	TYP.	MAX.	MIN.	TYP.	MAX.
A		3.3			0.130	
a1	0.7			0.028		
B	1.39		1.65	0.055		0.065
B1	0.91		1.04	0.036		0.041
b		0.5			0.020	
b1	0.38		0.5	0.015		0.020
D			9.8			0.386
E		8.8			0.346	
e		2.54			0.100	
e3		7.62			0.300	
e4		7.62			0.300	
F			7.1			0.280
I			4.8			0.189
L		3.3			0.130	
Z	0.44		1.6	0.017		0.063



P001F

SO-8 MECHANICAL DATA

DIM.	mm.			inch		
	MIN.	TYP.	MAX.	MIN.	TYP.	MAX.
A			1.75			0.068
a1	0.1		0.25	0.003		0.009
a2			1.65			0.064
a3	0.65		0.85	0.025		0.033
b	0.35		0.48	0.013		0.018
b1	0.19		0.25	0.007		0.010
C	0.25		0.5	0.010		0.019
c1	45° (typ.)					
D	4.8		5.0	0.189		0.196
E	5.8		6.2	0.228		0.244
e		1.27			0.050	
e3		3.81			0.150	
F	3.8		4.0	0.149		0.157
L	0.4		1.27	0.015		0.050
M			0.6			0.023
S	8° (max.)					

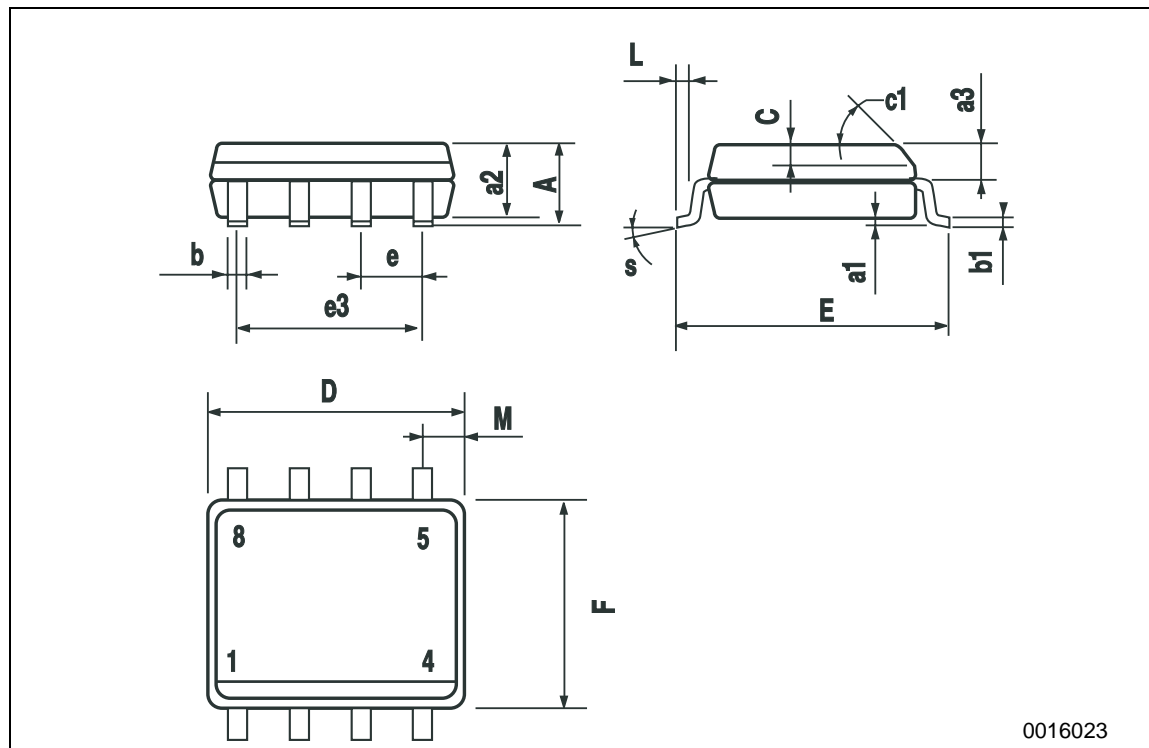

Information furnished is believed to be accurate and reliable. However, STMicroelectronics assumes no responsibility for the consequences of use of such information nor for any infringement of patents or other rights of third parties which may result from its use. No license is granted by implication or otherwise under any patent or patent rights of STMicroelectronics. Specifications mentioned in this publication are subject to change without notice. This publication supersedes and replaces all information previously supplied. STMicroelectronics products are not authorized for use as critical components in life support devices or systems without express written approval of STMicroelectronics.

© The ST logo is a registered trademark of STMicroelectronics

© 2002 STMicroelectronics - Printed in Italy - All Rights Reserved
STMicroelectronics GROUP OF COMPANIES

Australia - Brazil - Canada - China - Finland - France - Germany - Hong Kong - India - Israel - Italy - Japan - Malaysia - Malta - Morocco
Singapore - Spain - Sweden - Switzerland - United Kingdom - United States.

© <http://www.st.com>

