



# ST1CC40

## 3 A, 850 kHz monolithic synchronous step down constant current LED driver

### Features

- Step down current mode PWM regulator
- 3.5 V to 18 V input voltage
- Current sensing 100 mV Typ. with 5% tolerance
- Stand-by supply current: 6  $\mu$ A
- Cycle by cycle current limit with frequency foldback
- Integrated 95 m $\Omega$  and 69 m $\Omega$  power MOSFETs
- INH input pin
- All ceramic capacitor
- Internal compensate current mode control
- VFQFPN4x4-8L and SO-8 and packages

### Applications

- LED driving, MR16 bulb replacement
- General lighting, architectural lighting

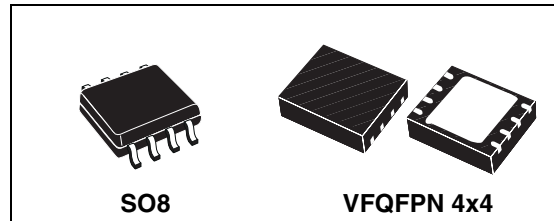

### Description

The ST1CC40 is a fixed frequency step-down DC-DC converter designed to operate as constant current source. The device operates with an input supply range from 3.5 V to 18 V and is able to provide up to 3 A output current with accurate regulation which makes it suitable to drive high power LEDs. Synchronous rectification improves overall system performance. The current is set by an external resistor through 100 mV Typ feedback voltage thus minimizing the power loss on the sensing resistor. 850 kHz switching frequency combined with low impedance ceramic capacitors minimize possible output ripple. The device is protected against thermal overheating, switching over current and output short circuit. The ST1CC40 is available in VFQFPN 4mm x 4mm 8 leads package, and standard SO-8.

Figure 1. Application circuit

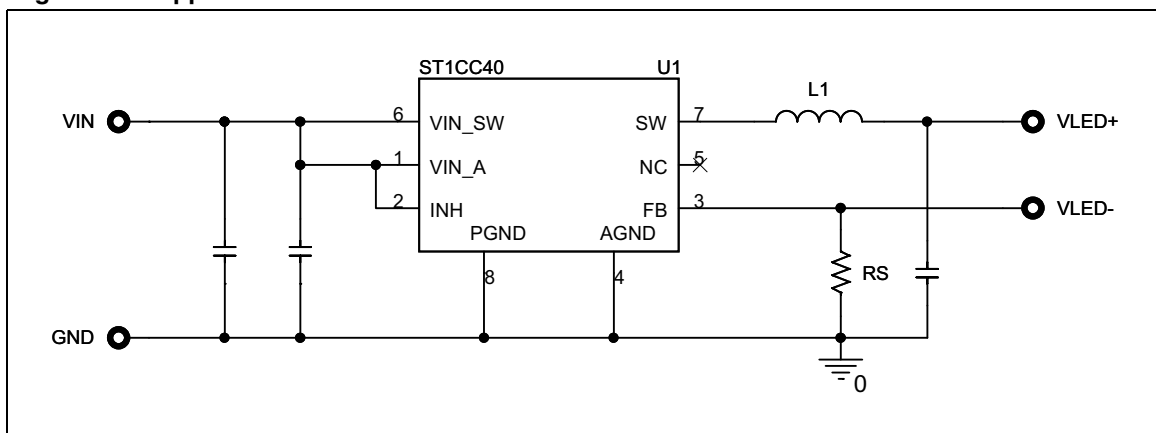

# Content

<b>1</b>	<b>Pin settings</b> .....	<b>3</b>
	1.1 Pin connection .....	3
	1.2 Pin description .....	3
<b>2</b>	<b>Maximum ratings</b> .....	<b>4</b>
<b>3</b>	<b>Thermal data</b> .....	<b>4</b>
<b>4</b>	<b>Electrical characteristics</b> .....	<b>5</b>
<b>5</b>	<b>Functional description</b> .....	<b>6</b>
<b>6</b>	<b>Package mechanical data</b> .....	<b>7</b>
<b>7</b>	<b>Order codes</b> .....	<b>10</b>
<b>8</b>	<b>Revision history</b> .....	<b>11</b>

# 1 Pin settings

## 1.1 Pin connection

Figure 2. Pin connection (top view)

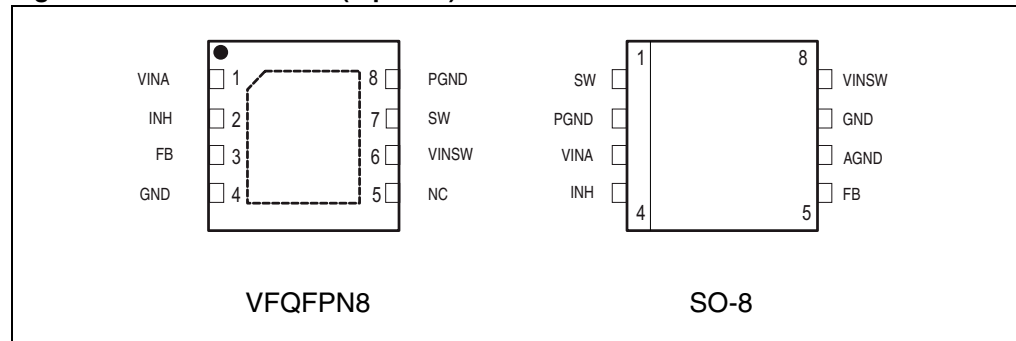

## 1.2 Pin description

Table 1. Pin description

N.		Type	Description
VFQFPN	S08-BW		
1	3	VINA	Unregulated DC input voltage
2	4	INH	Inhibit control input. Logic low disables operation. Toggling this pin with a periodic logic square wave of varying duty cycle at different frequencies controls the brightness of LEDs. Do leave this pin floating.
3	5	FB	Feedback input. The control loop regulates the current in such a way that the average voltage at the FB input is 100 mV (nominal). The cathode of the LED and the sense resistor ( $R_{sns}$ ) to ground to set the LED current should be connected at this point. The LED current is given by $I_{LED} = V_{FB}/R_{sns}$
4	6	AGND	Ground
5	-	NC	
6	8	VINSW	Power input voltage
7	1	SW	Regulator output switching pin
8	2	PGND	Power ground
-	7		Ground

## 2 Maximum ratings

**Table 2. Absolute maximum ratings**

Symbol	Parameter	Value	Unit
$V_{INSW}$	Power input voltage	-0.3 to 20	V
$V_{INA}$	Input voltage	-0.3 to 20	
$V_{EN}$	Enable voltage	-0.3 to $V_{INA}$	
$V_{SW}$	Output switching voltage	-1 to $V_{IN}$	
$V_{PG}$	Power Good	-0.3 to $V_{IN}$	
$V_{FB}$	Feedback voltage	-0.3 to 2.5	
$I_{FB}$	FB current	-1 to +1	mA
$P_{TOT}$	Power dissipation at $T_A < 60^\circ\text{C}$		W
$T_{OP}$	Operating junction temperature range	-40 to 125	$^\circ\text{C}$
$T_{stg}$	Storage temperature range	-55 to 150	$^\circ\text{C}$

## 3 Thermal data

**Table 3. Thermal data**

Symbol	Parameter	Value	Unit
$R_{thJA}$	Maximum thermal resistance junction-ambient <sup>(1)</sup>	VFQFPN	40
		SO8-BW	65

1. Package mounted on demonstration board.

## 4 Electrical characteristics

$T_J=25\text{ }^\circ\text{C}$ ,  $V_{CC}=12\text{ V}$ , unless otherwise specified.

**Table 4. Electrical characteristics**

Symbol	Parameter	Test condition	Values			Unit
			Min	Typ	Max	
$V_{IN}$	Operating input voltage range	(1)	3.5		18	V
$V_{FB}$	Feedback voltage		90	97	104	mV
$I_{FB}$	$V_{FB}$ pin bias current	(1)		50		nA
$R_{DSON-P}$	High side switch on resistance	$I_{SW}=750\text{mA}$		95		$\text{m}\Omega$
$R_{DSON-N}$	Low side switch on resistance	$I_{SW}=750\text{mA}$		69		$\text{m}\Omega$
$I_{LIM}$	Maximum limiting current	(2)	4.0		6.0	A
<b>Oscillator</b>						
$F_{SW}$	Switching frequency		0.7	0.850	1	MHz
D	Duty Cycle	(2)	0		100	%
<b>DC characteristics</b>						
$I_Q$	Quiescent current	$V_{INH} > 1.2\text{V}$		1.5	2.5	mA
$I_{QST-BY}$	Total stand-by quiescent current	$V_{INH} < 0.4\text{V}$		2	15	$\mu\text{A}$
<b>Enable</b>						
$V_{INH}$	INH threshold voltage	Device ON level	1.2			V
		Device OFF level			0.4	
$I_{INH}$	INH current			2		$\mu\text{A}$
<b>Soft start</b>						
$T_{SS}$	Soft start duration			1		ms
<b>Protection</b>						
$T_{SHDN}$	Thermal shutdown			150		$^\circ\text{C}$
	Hysteresis			15		

1. Specification referred to  $T_J$  from  $-40$  to  $+125^\circ\text{C}$ . Specification in the  $-40$  to  $+125^\circ\text{C}$  temperature range are assured by design, characterization and statistical correlation.

2. Guaranteed by design.

## 5 Functional description

The ST1CC40 is a constant frequency, current mode regulator with an internal power switch capable of generating 3 A constant current output. The architecture of the device is showed in the block diagram here below. The synchronous rectification saves the use of an external schottky diode and allows higher efficiency. The ST1CC40 is suitable to drive high power brightness LEDs.

0.85 MHz Typ switching frequency allows using tiny surface-mount components. The typical application requires only few external components 3 capacitors and the inductor. The LED brightness can be controlled by applying a periodic pulse signal to the INH/DIM pin and varying its duty cycle. This method controls the average light output by pulsing the LED current between the set value and zero and is called PWM dimming. Inhibit pin is used also to disable (logic low < 0.4 V) or enable (logic high > 1.2 V) the device. It can be connected to  $V_{inA}$  if not used. The ST1CC40 is provided with thermal shut down protection activated at 150 °C typ. Cycle-by-cycle over-current protection, protect the application and the regulator against over load outputs. An Internal soft start for start-up current limitation and power on delay helps to reduce the inrush current during start-up. The ST1CC40 offer 0.1 V Typ voltage reference with 5% max spread thus minimizes the power loss on the current sensing resistor.

The output current flowing through the LED string is determined by the value of the resistor  $R_{SNS}$  and is calculated by the following Equation:

$$R_{SNS} = V_{FB} / I_{OUT}$$

Where:

- $R_{SNS}$  is the value of the sensing resistor
- $V_{FB}$  is the reference voltage for the ST1CC40 in Volt (0.1 V typ)
- $I_{OUT}$  is the desired DC current in the LED string in Ampere

**Figure 3. Block diagram**

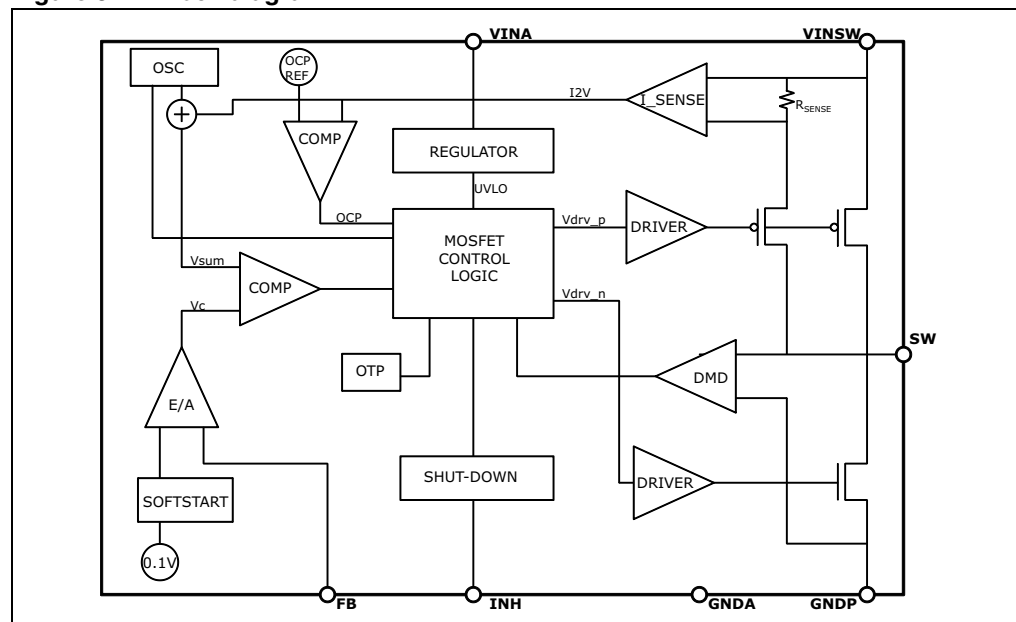

## 6 Package mechanical data

In order to meet environmental requirements, ST offers these devices in different grades of ECOPACK<sup>®</sup> packages, depending on their level of environmental compliance. ECOPACK<sup>®</sup> specifications, grade definitions and product status are available at: [www.st.com](http://www.st.com). ECOPACK<sup>®</sup> is an ST trademark.

Table 5. VFQFPN8 (4x4x1.08 mm) mechanical data

Dim.	mm			inch		
	Min	Typ	Max	Min	Typ	Max
A	0.80	0.90	1.00	0.0315	0.0354	0.0394
A1		0.02	0.05		0.0008	0.0020
A3		0.20			0.0079	
b	0.23	0.30	0.38	0.009	0.0117	0.0149
D	3.90	4.00	4.10	0.153	0.157	0.161
D2	2.82	3.00	3.23	0.111	0.118	0.127
E	3.90	4.00	4.10	0.153	0.157	0.161
E2	2.05	2.20	2.30	0.081	0.087	0.091
e		0.80			0.031	
L	0.40	0.50	0.60	0.016	0.020	0.024

Figure 4. Package dimensions

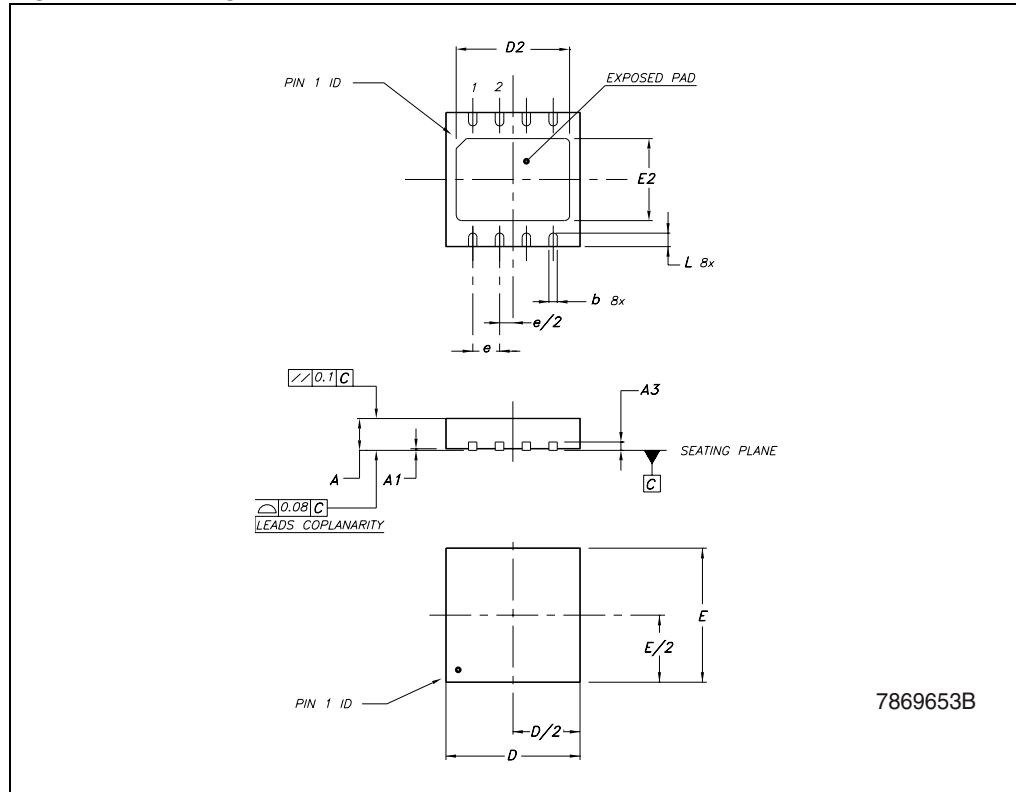

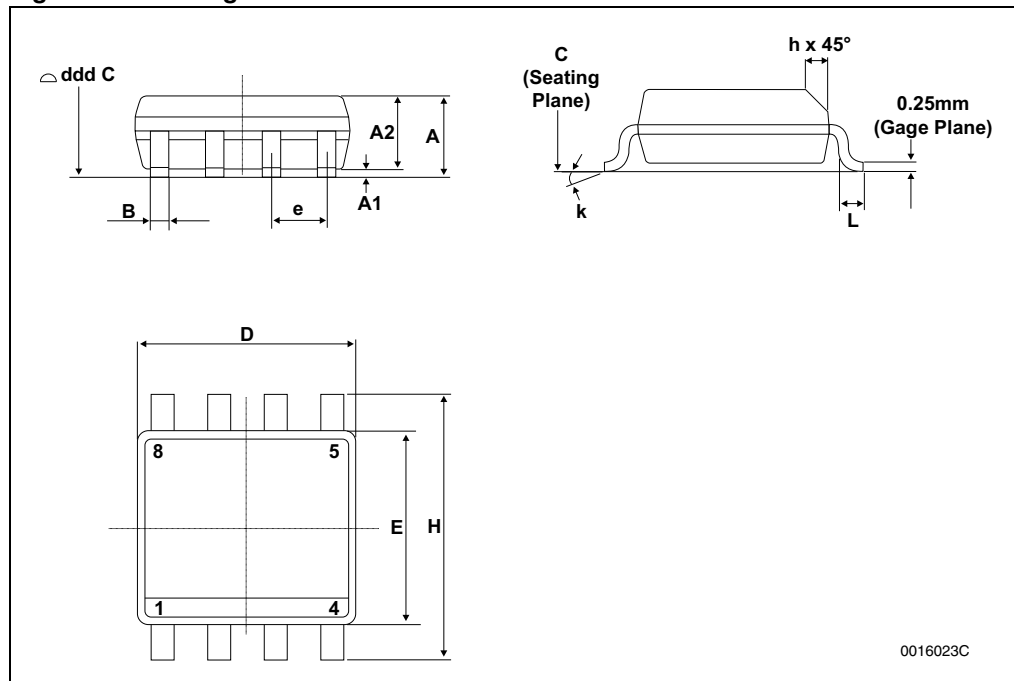

Table 6. SO8-BW mechanical data

Dim	mm			inch		
	Min	Typ	Max	Min	Typ	Max
A	135		1.75	0.053		0.069
A1	0.10		0.25	0.004		0.001
A2	1.10		1.65	0.043		0.065
B	0.33		0.51	0.013		0.020
C	0.19		0.25	0.007		0.01
D <sup>(1)</sup>	4.80		5.00	0.1890	0.1929	0.1969
E	3.80		4.00	0.15		0.157
e		1.27			0.050	
H	5.80		6.20	0.228		0.244
h	0.25		0.50	0.0098		0.0197
L	0.40		1.27	0.0157		0.0500
k	0°(min.), 8°(max.)					
ddd			0.10			0.0039

1. Dimensions D does not include mold flash, protrusions or gate burrs. Mold flash, protrusions or gate burrs shall not exceed 0.15mm (.006inch) in total (both side).

Figure 5. Package dimensions



## 7 Order codes

**Table 7. Ordering information**

<b>Order codes</b>	<b>Package</b>
ST1CC40PUR	VFQFPN 4x4 8L
ST1CC40DR	SO8-BW

## 8 Revision history

**Table 8. Document revision history**

Date	Revision	Changes
04-Mar-2011	1	First release

**Please Read Carefully:**

Information in this document is provided solely in connection with ST products. STMicroelectronics NV and its subsidiaries ("ST") reserve the right to make changes, corrections, modifications or improvements, to this document, and the products and services described herein at any time, without notice.

All ST products are sold pursuant to ST's terms and conditions of sale.

Purchasers are solely responsible for the choice, selection and use of the ST products and services described herein, and ST assumes no liability whatsoever relating to the choice, selection or use of the ST products and services described herein.

No license, express or implied, by estoppel or otherwise, to any intellectual property rights is granted under this document. If any part of this document refers to any third party products or services it shall not be deemed a license grant by ST for the use of such third party products or services, or any intellectual property contained therein or considered as a warranty covering the use in any manner whatsoever of such third party products or services or any intellectual property contained therein.

**UNLESS OTHERWISE SET FORTH IN ST'S TERMS AND CONDITIONS OF SALE ST DISCLAIMS ANY EXPRESS OR IMPLIED WARRANTY WITH RESPECT TO THE USE AND/OR SALE OF ST PRODUCTS INCLUDING WITHOUT LIMITATION IMPLIED WARRANTIES OF MERCHANTABILITY, FITNESS FOR A PARTICULAR PURPOSE (AND THEIR EQUIVALENTS UNDER THE LAWS OF ANY JURISDICTION), OR INFRINGEMENT OF ANY PATENT, COPYRIGHT OR OTHER INTELLECTUAL PROPERTY RIGHT.**

**UNLESS EXPRESSLY APPROVED IN WRITING BY AN AUTHORIZED ST REPRESENTATIVE, ST PRODUCTS ARE NOT RECOMMENDED, AUTHORIZED OR WARRANTED FOR USE IN MILITARY, AIR CRAFT, SPACE, LIFE SAVING, OR LIFE SUSTAINING APPLICATIONS, NOR IN PRODUCTS OR SYSTEMS WHERE FAILURE OR MALFUNCTION MAY RESULT IN PERSONAL INJURY, DEATH, OR SEVERE PROPERTY OR ENVIRONMENTAL DAMAGE. ST PRODUCTS WHICH ARE NOT SPECIFIED AS "AUTOMOTIVE GRADE" MAY ONLY BE USED IN AUTOMOTIVE APPLICATIONS AT USER'S OWN RISK.**

Resale of ST products with provisions different from the statements and/or technical features set forth in this document shall immediately void any warranty granted by ST for the ST product or service described herein and shall not create or extend in any manner whatsoever, any liability of ST.

ST and the ST logo are trademarks or registered trademarks of ST in various countries.

Information in this document supersedes and replaces all information previously supplied.

The ST logo is a registered trademark of STMicroelectronics. All other names are the property of their respective owners.

© 2011 STMicroelectronics - All rights reserved

STMicroelectronics group of companies

Australia - Belgium - Brazil - Canada - China - Czech Republic - Finland - France - Germany - Hong Kong - India - Israel - Italy - Japan - Malaysia - Malta - Morocco - Philippines - Singapore - Spain - Sweden - Switzerland - United Kingdom - United States of America

[www.st.com](http://www.st.com)