

Power Inductors CK Series

OUTLINE

High efficiency and Low DCR power inductor for battery-driven portable electric equipment power supplies (DC-DC converter, switching power supply) and other electronic equipment.

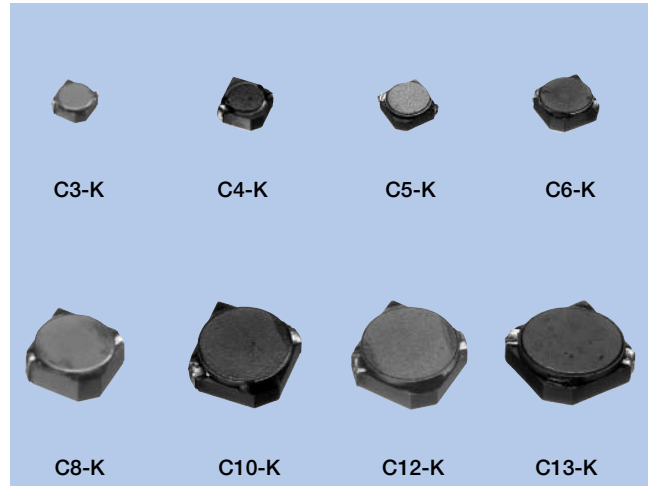

FEATURES

1. Low DCR
2. Low profile and high current
3. Magnetically shielded structure for electromagnetic interference

APPLICATIONS

For DSCs, DVD/MP3 Players, Mobile Phones, PDAs, Notebook Computers, LCD TVs, PDP TVs, Car Navigations, and other electronic equipment.

SPECIFICATIONS

Type	Size (mm)	H length (mm)	Inductance	Operational Frequency (kHz)	Rated Current (A)	DC Resistance (mΩ)	Pcs/Reel
C3-K1.5L	3.8×3.8	1.5	2.2~68	10~500	0.14~0.85	60~1050	3000
C3-K1.8L	3.8×3.8	1.8	1.2~68	10~500	0.27~1.80	25~980	3000
C4-K1.8R	4.8×4.8	1.9	1.0~150	10~500	0.22~2.40	18~1420	2000
C4-K1.8RA	4.8×4.8	1.9	1.0~150	10~500	0.31~3.50	22~2100	2000
C4-K3L	4.8×4.8	3.0	1.0~150	10~500	0.18~2.60	12~485	2000
C4-K3LA	4.8×4.8	3.0	1.0~150	10~500	0.36~3.00	13~976	2000
C5-K1.8L	5.6×5.6	1.9	1.0~150	10~500	0.28~3.90	10~1083	2000
C5-K1.8LA	5.6×5.6	1.8	1.2~150	10~500	0.30~3.10	17~1452	2000
C5-K2.5L	5.6×5.6	2.6	1.0~150	10~500	0.30~3.40	22~832	2000
C5-K3L	5.6×5.6	3.0	1.0~150	10~500	0.30~3.78	15~631	2000
C5-K3LA	5.6×5.6	3.0	1.2~100	10~500	0.50~3.50	11~575	2000
C6-K1.8L	6.6×6.6	1.9	2.2~150	10~500	0.48~3.00	35~1300	1000
C6-K3L	6.6×6.6	3.2	1.0~150	10~500	0.40~5.50	9~539	1000
C6-K3LA	6.6×6.6	3.2	1.2~150	10~500	0.55~5.60	16~685	1000
C6-K5LA	6.6×6.6	5.0	1.0~100	10~500	0.80~7.00	10~510	500
C8-K4L	8×8	4.0	1.0~150	10~500	0.73~7.00	10~421	500
C8-K5L	8×8	5.0	1.5~150	10~500	0.73~6.50	12~348	500
C8-K5LA	8×8	5.0	1.2~150	10~500	1.10~10.30	11~438	500
C10-K3L	10×10	3.0	1.2~150	10~500	0.70~6.20	16~696	500
C10-K4L	10×10	4.0	1.0~150	10~500	0.85~7.10	11~313	500
C12-K4.5L	11.5×11.5	4.5	1.0~150	10~500	1.20~7.10	7~430	500
C12-K7.5L	11.5×11.5	7.5	1.0~150	10~500	2.20~23.5	6~136	400
C13-K4.5L	13×13	4.5	1.0~150	10~500	1.33~11.0	8~339	500

DATA LIST (C3-K1.5L Series)

C3-K1.5L (Height : 1.5mm max.)

Item	Stamp	Inductance			DCR (mΩ) typ.	DC Current (A)	
		(μH)	Tolerance (%)	Test Freq. (kHz)		Inductance -10% typ.	Temp. Δ25K typ.
DE	2R2	2.2	±30	1kHz	60	0.85	1.10
DF	2R7	2.7	±30	1kHz	70	0.70	1.02
DG	3R3	3.3	±30	1kHz	80	0.66	0.96
DH	3R9	3.9	±30	1kHz	90	0.60	0.90
DJ	4R7	4.7	±30	1kHz	95	0.53	0.84
DK	5R6	5.6	±30	1kHz	100	0.50	0.78
DL	6R8	6.8	±30	1kHz	110	0.48	0.73
DM	8R2	8.2	±30	1kHz	120	0.45	0.68
EA	100	10	±20	1kHz	160	0.40	0.60
EB	120	12	±20	1kHz	225	0.34	0.54
EC	150	15	±20	1kHz	250	0.32	0.51
ED	180	18	±20	1kHz	260	0.30	0.48
EE	220	22	±20	1kHz	300	0.28	0.40
EF	270	27	±20	1kHz	430	0.24	0.38
EG	330	33	±20	1kHz	490	0.21	0.36
EH	390	39	±20	1kHz	610	0.20	0.32
EJ	470	47	±20	1kHz	740	0.18	0.30
EK	560	56	±20	1kHz	950	0.16	0.28
EL	680	68	±20	1kHz	1050	0.14	0.26

DATA LIST (C3-K1.8L Series)

C3-K1.8L (Height : 1.8mm max.)

Item	Stamp	Inductance			DCR (mΩ) typ.	DC Current (A)	
		(μH)	Tolerance (%)	Test Freq. (kHz)		Inductance -10% typ.	Temp. Δ25K typ.
DB	1R2	1.2	±30	1kHz	25	1.80	2.30
DD	1R8	1.8	±30	1kHz	30	1.55	2.10
DE	2R2	2.2	±30	1kHz	43	1.35	1.90
DF	2R7	2.7	±30	1kHz	47	1.25	1.80
DG	3R3	3.3	±30	1kHz	55	1.15	1.70
DH	3R9	3.9	±30	1kHz	65	1.05	1.50
DJ	4R7	4.7	±30	1kHz	75	0.92	1.40
DK	5R6	5.6	±30	1kHz	100	0.86	1.20
DL	6R8	6.8	±30	1kHz	110	0.81	1.10
DM	8R2	8.2	±30	1kHz	120	0.78	1.00
EA	100	10	±20	1kHz	160	0.70	0.90
EB	120	12	±20	1kHz	175	0.65	0.82
EC	150	15	±20	1kHz	210	0.58	0.75
ED	180	18	±20	1kHz	275	0.52	0.65
EE	220	22	±20	1kHz	300	0.46	0.60
EF	270	27	±20	1kHz	390	0.42	0.52
EG	330	33	±20	1kHz	520	0.38	0.46
EH	390	39	±20	1kHz	560	0.35	0.42
EJ	470	47	±20	1kHz	775	0.31	0.36
EK	560	56	±20	1kHz	860	0.29	0.33
EL	680	68	±20	1kHz	980	0.27	0.30

DATA LIST (C4-K1.8R Series)

C4-K1.8R (Height : 1.9mm max.)

Item	Stamp	Inductance (μ H)	Inductance		DCR (m Ω) typ.	DC Current (A)	
			Tolerance (%)	Test Freq. (kHz)		Inductance -10% typ.	Temp. Δ 25K typ.
DA	1R0	1.0	\pm 30	1kHz	18	2.40	3.20
DC	1R5	1.5	\pm 30	1kHz	23	2.20	2.70
DE	2R2	2.2	\pm 30	1kHz	29	2.00	2.40
DF	2R7	2.7	\pm 30	1kHz	34	1.80	2.30
DG	3R3	3.3	\pm 30	1kHz	39	1.70	2.20
DH	3R9	3.9	\pm 30	1kHz	53	1.50	2.10
DJ	4R7	4.7	\pm 30	1kHz	57	1.40	1.90
DK	5R6	5.6	\pm 30	1kHz	65	1.30	1.80
DL	6R8	6.8	\pm 30	1kHz	82	1.20	1.60
DM	8R2	8.2	\pm 30	1kHz	95	1.10	1.55
EA	100	10	\pm 20	1kHz	110	0.98	1.25
EB	120	12	\pm 20	1kHz	117	0.88	1.20
EC	150	15	\pm 20	1kHz	165	0.80	1.10
ED	180	18	\pm 20	1kHz	185	0.75	1.05
EE	220	22	\pm 20	1kHz	212	0.70	1.00
EF	270	27	\pm 20	1kHz	288	0.60	0.80
EG	330	33	\pm 20	1kHz	345	0.52	0.70
EH	390	39	\pm 20	1kHz	487	0.45	0.60
EJ	470	47	\pm 20	1kHz	545	0.40	0.55
EK	560	56	\pm 20	1kHz	595	0.35	0.53
EL	680	68	\pm 20	1kHz	693	0.33	0.50
EM	820	82	\pm 20	1kHz	850	0.31	0.45
FA	101	100	\pm 20	1kHz	1030	0.29	0.38
FB	121	120	\pm 20	1kHz	1260	0.25	0.32
FC	151	150	\pm 20	1kHz	1420	0.22	0.30

DATA LIST (C4-K1.8RA Series)

C4-K1.8RA (Height : 1.9mm max.)

Item	Stamp	Inductance (μ H)	Inductance		DCR (m Ω) typ.	DC Current (A)	
			Tolerance (%)	Test Freq. (kHz)		Inductance -10% typ.	Temp. Δ 25K typ.
DA	1R0	1.0	\pm 30	1kHz	22	3.50	2.30
DC	1R5	1.5	\pm 30	1kHz	26	3.10	2.10
DD	1R8	1.8	\pm 30	1kHz	32	2.80	2.00
DF	2R7	2.7	\pm 30	1kHz	39	2.20	1.80
DG	3R3	3.3	\pm 30	1kHz	52	2.10	1.50
DH	3R9	3.9	\pm 30	1kHz	70	2.00	1.30
DJ	4R7	4.7	\pm 30	1kHz	80	1.90	1.20
DK	5R6	5.6	\pm 30	1kHz	86	1.70	1.15
DL	6R8	6.8	\pm 30	1kHz	97	1.50	1.05
DM	8R2	8.2	\pm 30	1kHz	137	1.40	0.90
EA	100	10	\pm 20	1kHz	147	1.30	0.82
EB	120	12	\pm 20	1kHz	181	1.10	0.71
EC	150	15	\pm 20	1kHz	244	0.96	0.59
ED	180	18	\pm 20	1kHz	271	0.93	0.55
EE	220	22	\pm 20	1kHz	305	0.82	0.50
EF	270	27	\pm 20	1kHz	375	0.73	0.44
EG	330	33	\pm 20	1kHz	510	0.65	0.42
EH	390	39	\pm 20	1kHz	550	0.61	0.38
EJ	470	47	\pm 20	1kHz	635	0.57	0.35
EK	560	56	\pm 20	1kHz	740	0.51	0.32
EL	680	68	\pm 20	1kHz	1110	0.46	0.28
EM	820	82	\pm 20	1kHz	1230	0.43	0.26
FA	101	100	\pm 20	1kHz	1345	0.41	0.24
FB	121	120	\pm 20	1kHz	1550	0.37	0.22
FC	151	150	\pm 20	1kHz	2100	0.31	0.19

DATA LIST (C4-K3L Series)

C4-K3L (Height : 3mm max.)

Item	Stamp	Inductance			DCR (mΩ) typ.	DC Current (A)	
		(μH)	Tolerance (%)	Test Freq. (kHz)		Inductance -10% typ.	Temp. Δ25K typ.
DA	1R0	1.0	±30	1kHz	12	2.60	-
DC	1R5	1.5	±30	1kHz	15	1.80	-
DE	2R2	2.2	±30	1kHz	18	1.60	-
DG	3R3	3.3	±30	1kHz	21	1.20	-
DH	3R9	3.9	±30	1kHz	23	1.10	-
DJ	4R7	4.7	±30	1kHz	25	1.05	-
DK	5R6	5.6	±30	1kHz	27	0.90	-
DL	6R8	6.8	±30	1kHz	33	0.80	-
DM	8R2	8.2	±30	1kHz	38	0.75	-
EA	100	10	±30	1kHz	47	0.70	-
EB	120	12	±20	1kHz	54	0.65	-
EC	150	15	±20	1kHz	65	0.60	-
ED	180	18	±20	1kHz	95	0.50	-
EE	220	22	±20	1kHz	111	0.47	-
EF	270	27	±20	1kHz	122	0.45	-
EG	330	33	±20	1kHz	135	0.40	-
EH	390	39	±20	1kHz	180	0.35	-
EJ	470	47	±20	1kHz	196	0.32	-
EK	560	56	±20	1kHz	221	0.30	-
EL	680	68	±20	1kHz	258	0.27	-
EM	820	82	±20	1kHz	289	0.25	-
FA	101	100	±20	1kHz	381	0.22	-
FB	121	120	±20	1kHz	437	0.20	-
FC	151	150	±20	1kHz	485	0.18	-

DATA LIST (C4-K3LA Series)

C4-K3LA (Height : 3mm max.)

Item	Stamp	Inductance			DCR (mΩ) typ.	DC Current (A)	
		(μH)	Tolerance (%)	Test Freq. (kHz)		Inductance -10% typ.	Temp. Δ25K typ.
DA	1R0	1.0	±30	1kHz	13	3.00	4.00
DC	1R5	1.5	±30	1kHz	15	2.70	3.60
DD	1R8	1.8	±30	1kHz	19	2.40	3.20
DF	2R7	2.7	±30	1kHz	22	2.20	2.90
DG	3R3	3.3	±30	1kHz	24	2.15	2.80
DH	3R9	3.9	±30	1kHz	28	2.10	2.70
DK	5R6	5.6	±30	1kHz	47	1.75	2.50
DL	6R8	6.8	±30	1kHz	52	1.50	2.20
DM	8R2	8.2	±30	1kHz	57	1.30	2.00
EA	100	10	±20	1kHz	67	1.10	1.75
EB	120	12	±20	1kHz	72	1.00	1.60
EC	150	15	±20	1kHz	83	0.85	1.40
ED	180	18	±20	1kHz	127	0.80	1.30
EE	220	22	±20	1kHz	155	0.75	1.20
EF	270	27	±20	1kHz	177	0.70	1.10
EG	330	33	±20	1kHz	231	0.65	1.05
EH	390	39	±20	1kHz	252	0.60	0.90
EJ	470	47	±20	1kHz	281	0.50	0.80
EK	560	56	±20	1kHz	402	0.45	0.70
EL	680	68	±20	1kHz	449	0.42	0.60
EM	820	82	±20	1kHz	522	0.40	0.55
FA	101	100	±20	1kHz	754	0.38	0.50
FB	121	120	±20	1kHz	828	0.37	0.48
FC	151	150	±20	1kHz	976	0.36	0.44

DATA LIST (C5-K1.8L Series)

C5-K1.8L (Height : 1.9mm max.)

Item	Stamp	Inductance			DCR (mΩ) typ.	DC Current (A)	
		(μH)	Tolerance (%)	Test Freq. (kHz)		Inductance -10% typ.	Temp. Δ25K typ.
DA	1R0	1.0	±30	1kHz	10	3.90	5.50
DB	1R2	1.2	±30	1kHz	13	3.10	4.30
DD	1R8	1.8	±30	1kHz	19	2.50	4.00
DF	2R7	2.7	±30	1kHz	23	2.20	3.20
DG	3R3	3.3	±30	1kHz	32	1.80	2.80
DJ	4R7	4.7	±30	1kHz	38	1.50	2.60
DK	5R6	5.6	±30	1kHz	43	1.40	2.55
DL	6R8	6.8	±30	1kHz	58	1.30	2.05
DM	8R2	8.2	±30	1kHz	64	1.27	2.00
EA	100	10	±20	1kHz	85	1.15	1.65
EB	120	12	±20	1kHz	94	1.10	1.60
EC	150	15	±20	1kHz	112	0.90	1.50
ED	180	18	±20	1kHz	138	0.70	1.30
EE	220	22	±20	1kHz	163	0.68	1.15
EF	270	27	±20	1kHz	186	0.65	1.10
EG	330	33	±20	1kHz	243	0.55	1.00
EH	390	39	±20	1kHz	275	0.50	0.90
EJ	470	47	±20	1kHz	410	0.45	0.70
EK	560	56	±20	1kHz	432	0.43	0.65
EL	680	68	±20	1kHz	476	0.36	0.60
EM	820	82	±20	1kHz	716	0.34	0.50
FA	101	100	±20	1kHz	805	0.31	0.46
FB	121	120	±20	1kHz	940	0.30	0.44
FC	151	150	±20	1kHz	1083	0.28	0.40

DATA LIST (C5-K1.8LA Series)

C5-K1.8LA (Height : 1.8mm max.)

Item	Stamp	Inductance			DCR (mΩ) typ.	DC Current (A)	
		(μH)	Tolerance (%)	Test Freq. (kHz)		Inductance -10% typ.	Temp. Δ25K typ.
DB	1R2	1.2	±30	1kHz	17	3.10	3.37
DD	1R8	1.8	±30	1kHz	21	2.50	3.01
DF	2R7	2.7	±30	1kHz	30	2.23	2.60
DG	3R3	3.3	±30	1kHz	35	2.08	2.30
DH	3R9	3.9	±30	1kHz	51	1.92	2.00
DJ	4R7	4.7	±30	1kHz	57	1.70	1.86
DK	5R6	5.6	±30	1kHz	77	1.62	1.80
DL	6R8	6.8	±30	1kHz	85	1.54	1.75
DM	8R2	8.2	±30	1kHz	109	1.48	1.61
EA	100	10	±20	1kHz	118	1.40	1.50
EB	120	12	±20	1kHz	129	1.20	1.24
EC	150	15	±20	1kHz	165	0.97	1.03
ED	180	18	±20	1kHz	175	0.94	0.92
EE	220	22	±20	1kHz	226	0.90	0.83
EF	270	27	±20	1kHz	281	0.77	0.74
EG	330	33	±20	1kHz	382	0.64	0.63
EH	390	39	±20	1kHz	420	0.58	0.61
EJ	470	47	±20	1kHz	474	0.53	0.59
EK	560	56	±20	1kHz	581	0.49	0.54
EL	680	68	±20	1kHz	654	0.45	0.49
EM	820	82	±20	1kHz	836	0.40	0.44
FA	101	100	±20	1kHz	965	0.36	0.39
FB	121	120	±20	1kHz	1280	0.33	0.35
FC	151	150	±20	1kHz	1452	0.30	0.32

DATA LIST (C5-K2.5L Series)

C5-K2.5L (Height : 2.5mm max.)

Item	Stamp	Inductance			DCR (mΩ) typ.	DC Current (A)	
		(μH)	Tolerance (%)	Test Freq. (kHz)		Inductance -10% typ.	Temp. Δ25K typ.
DA	1R0	1.0	±30	1kHz	22	3.40	4.30
DC	1R5	1.5	±30	1kHz	25	2.90	3.80
DE	2R2	2.2	±30	1kHz	27	2.30	3.60
DG	3R3	3.3	±30	1kHz	29	2.00	3.20
DJ	4R7	4.7	±30	1kHz	31	1.80	2.80
DK	5R6	5.6	±30	1kHz	39	1.50	2.50
DL	6R8	6.8	±30	1kHz	45	1.45	2.30
DM	8R2	8.2	±30	1kHz	53	1.40	1.90
EA	100	10	±30	1kHz	58	1.20	1.80
EB	120	12	±30	1kHz	66	1.10	1.70
EC	150	15	±20	1kHz	125	0.90	1.30
ED	180	18	±20	1kHz	133	0.80	1.20
EE	220	22	±20	1kHz	151	0.70	1.10
EF	270	27	±20	1kHz	165	0.65	1.00
EG	330	33	±20	1kHz	193	0.60	0.95
EH	390	39	±20	1kHz	254	0.56	0.85
EJ	470	47	±20	1kHz	285	0.53	0.80
EK	560	56	±20	1kHz	369	0.50	0.75
EL	680	68	±20	1kHz	410	0.46	0.70
EM	820	82	±20	1kHz	459	0.43	0.65
FA	101	100	±20	1kHz	650	0.40	0.55
FB	121	120	±20	1kHz	723	0.35	0.52
FC	151	150	±20	1kHz	832	0.30	0.49

DATA LIST (C5-K3L Series)

C5-K3L (Height : 3mm max.)

Item	Stamp	Inductance			DCR (mΩ) typ.	DC Current (A)	
		(μH)	Tolerance (%)	Test Freq. (kHz)		Inductance -10% typ.	Temp. Δ25K typ.
DA	1R0	1.0	±30	1kHz	15	3.78	4.80
DC	1R5	1.5	±30	1kHz	18	3.06	4.50
DD	1R8	1.8	±30	1kHz	21	2.70	4.30
DF	2R7	2.7	±30	1kHz	24	2.25	3.80
DG	3R3	3.3	±30	1kHz	28	2.07	3.60
DH	3R9	3.9	±30	1kHz	30	1.62	2.80
DJ	4R7	4.7	±30	1kHz	34	1.53	2.60
DK	5R6	5.6	±30	1kHz	38	1.50	2.30
DL	6R8	6.8	±30	1kHz	43	1.35	2.00
DM	8R2	8.2	±30	1kHz	44	1.19	1.90
EA	100	10	±30	1kHz	46	1.10	1.80
EB	120	12	±30	1kHz	50	0.95	1.70
EC	150	15	±20	1kHz	69	0.88	1.60
ED	180	18	±20	1kHz	88	0.82	1.50
EE	220	22	±20	1kHz	92	0.80	1.40
EF	270	27	±20	1kHz	134	0.66	1.30
EG	330	33	±20	1kHz	142	0.60	1.20
EH	390	39	±20	1kHz	167	0.55	1.10
EJ	470	47	±20	1kHz	232	0.48	1.00
EK	560	56	±20	1kHz	265	0.46	0.90
EL	680	68	±20	1kHz	325	0.43	0.80
EM	820	82	±20	1kHz	383	0.39	0.70
FA	101	100	±20	1kHz	499	0.35	0.60
FB	121	120	±20	1kHz	553	0.32	0.55
FC	151	150	±20	1kHz	631	0.30	0.50

DATA LIST (C5-K3LA Series)

C5-K3LA (Height : 3mm max.)

Item	Stamp	Inductance			DCR (mΩ) typ.	DC Current (A)	
		(μH)	Tolerance (%)	Test Freq. (kHz)		Inductance -10% typ.	Temp. Δ25K typ.
DB	1R2	1.2	±30	1kHz	11	3.50	4.80
DD	1R8	1.8	±30	1kHz	15	3.20	3.50
DE	2R2	2.2	±30	1kHz	20	3.10	3.20
DG	3R3	3.3	±30	1kHz	30	2.40	2.70
DJ	4R7	4.7	±30	1kHz	33	2.10	2.40
DK	5R6	5.6	±30	1kHz	42	2.00	2.30
DL	6R8	6.8	±30	1kHz	46	1.95	2.20
DM	8R2	8.2	±30	1kHz	51	1.90	2.15
EA	100	10	±20	1kHz	65	1.55	1.80
EB	120	12	±20	1kHz	79	1.40	1.60
EC	150	15	±20	1kHz	83	1.25	1.55
ED	180	18	±20	1kHz	113	1.20	1.45
EE	220	22	±20	1kHz	120	1.10	1.40
EF	270	27	±20	1kHz	158	1.00	1.20
EG	330	33	±20	1kHz	209	0.90	0.95
EH	390	39	±20	1kHz	238	0.75	0.90
EJ	470	47	±20	1kHz	300	0.70	0.80
EK	560	56	±20	1kHz	375	0.62	0.75
EL	680	68	±20	1kHz	429	0.60	0.65
EM	820	82	±20	1kHz	538	0.52	0.60
FA	101	100	±20	1kHz	575	0.50	0.55

DATA LIST (C6-K1.8L Series)

C6-K1.8L (Height : 1.8mm max.)

Item	Stamp	Inductance			DCR (mΩ) typ.	DC Current (A)	
		(μH)	Tolerance (%)	Test Freq. (kHz)		Inductance -10% typ.	Temp. Δ25K typ.
DE	2R2	2.2	30	1kHz	35	3.00	2.60
DG	3R3	3.3	30	1kHz	46	2.80	2.50
DH	3R9	3.9	30	1kHz	54	2.50	2.10
DK	5R6	5.6	30	1kHz	61	2.30	1.90
DL	6R8	6.8	30	1kHz	68	2.20	1.80
DM	8R2	8.2	30	1kHz	74	2.00	1.70
EA	100	10	20	1kHz	81	1.80	1.60
EB	120	12	20	1kHz	115	1.60	1.40
EC	150	15	20	1kHz	135	1.40	1.30
ED	180	18	20	1kHz	145	1.30	1.10
EE	220	22	20	1kHz	195	1.20	1.00
EF	270	27	20	1kHz	208	1.10	0.95
EG	330	33	20	1kHz	296	1.00	0.85
EH	390	39	20	1kHz	328	0.90	0.75
EJ	470	47	20	1kHz	365	0.80	0.70
EK	560	56	20	1kHz	513	0.75	0.65
EL	680	68	20	1kHz	595	0.68	0.60
EM	820	82	20	1kHz	625	0.62	0.55
FA	101	100	20	1kHz	978	0.55	0.45
FB	121	120	20	1kHz	1100	0.51	0.40
FC	151	150	20	1kHz	1300	0.48	0.36

DATA LIST (C6-K3L Series)

C6-K3L (Height : 3.2mm max.)

Item	Stamp	Inductance			DCR (mΩ) typ.	DC Current (A)	
		(μH)	Tolerance (%)	Test Freq. (kHz)		Inductance -10% typ.	Temp. Δ25K typ.
DA	1R0	1.0	±30	1kHz	9	5.50	-
DC	1R5	1.5	±30	1kHz	11	4.60	-
DE	2R2	2.2	±30	1kHz	13	4.10	-
DG	3R3	3.3	±30	1kHz	17	3.30	-
DH	3R9	3.9	±30	1kHz	18	2.60	-
DJ	4R7	4.7	±30	1kHz	20	2.40	-
DL	6R8	6.8	±30	1kHz	28	1.90	-
DM	8R2	8.2	±30	1kHz	39	1.80	-
EA	100	10	±30	1kHz	43	1.60	-
EB	120	12	±20	1kHz	100	1.40	-
EC	150	15	±20	1kHz	121	1.30	-
ED	180	18	±20	1kHz	125	1.20	-
EE	220	22	±20	1kHz	143	1.10	-
EF	270	27	±20	1kHz	160	1.00	-
EG	330	33	±20	1kHz	176	0.90	-
EH	390	39	±20	1kHz	195	0.80	-
EJ	470	47	±20	1kHz	213	0.73	-
EK	560	56	±20	1kHz	244	0.70	-
EL	680	68	±20	1kHz	274	0.50	-
EM	820	82	±20	1kHz	306	0.45	-
FA	101	100	±20	1kHz	385	0.43	-
FB	121	120	±20	1kHz	463	0.42	-
FC	151	150	±20	1kHz	539	0.40	-

DATA LIST (C6-K3LA Series)

C6-K3LA (Height : 3.2mm max.)

Item	Stamp	Inductance			DCR (mΩ) typ.	DC Current (A)	
		(μH)	Tolerance (%)	Test Freq. (kHz)		Inductance -10% typ.	Temp. Δ25K typ.
DB	1R2	1.2	±30	1kHz	16	5.60	-
DD	1R8	1.8	±30	1kHz	20	4.80	-
DF	2R7	2.7	±30	1kHz	23	4.00	-
DG	3R3	3.3	±30	1kHz	27	3.60	-
DJ	4R7	4.7	±30	1kHz	30	3.30	-
DK	5R6	5.6	±30	1kHz	34	3.00	-
DL	6R8	6.8	±30	1kHz	38	2.70	-
DM	8R2	8.2	±30	1kHz	42	2.30	-
EA	100	10	±20	1kHz	52	2.10	-
EB	120	12	±20	1kHz	61	1.90	-
EC	150	15	±20	1kHz	73	1.80	-
ED	180	18	±20	1kHz	80	1.70	-
EE	220	22	±20	1kHz	125	1.50	-
EF	270	27	±20	1kHz	131	1.30	-
EG	330	33	±20	1kHz	188	1.20	-
EH	390	39	±20	1kHz	204	1.00	-
EJ	470	47	±20	1kHz	222	0.90	-
EK	560	56	±20	1kHz	251	0.84	-
EL	680	68	±20	1kHz	282	0.80	-
EM	820	82	±20	1kHz	374	0.75	-
FA	101	100	±20	1kHz	458	0.70	-
FB	121	120	±20	1kHz	545	0.60	-
FC	151	150	±20	1kHz	685	0.55	-

DATA LIST (C6-K5LA Series)

C6-K5LA (Height : 5mm max.)

Item	Stamp	Inductance			DCR (mΩ) typ.	DC Current (A)	
		(μH)	Tolerance (%)	Test Freq. (kHz)		Inductance -10% typ.	Temp. Δ40K typ.
DA	1R0	1.0	±30	1kHz	10	7.00	5.20
DC	1R5	1.5	±30	1kHz	12	6.20	4.90
DE	2R2	2.2	±30	1kHz	14	5.50	4.50
DG	3R3	3.3	±30	1kHz	18	4.80	4.30
DH	3R9	3.9	±30	1kHz	22	4.30	4.00
DJ	4R7	4.7	±30	1kHz	34	3.90	3.40
DL	6R8	6.8	±30	1kHz	40	3.60	3.00
DM	8R2	8.2	±30	1kHz	45	3.40	2.80
EA	100	10	±30	1kHz	50	3.10	2.60
EB	120	12	±30	1kHz	55	2.90	2.50
EC	150	15	±20	1kHz	60	2.70	2.40
ED	180	18	±20	1kHz	80	2.20	2.20
EE	220	22	±20	1kHz	90	2.10	2.10
EF	270	27	±20	1kHz	100	2.00	1.90
EG	330	33	±20	1kHz	140	1.80	1.70
EH	390	39	±20	1kHz	160	1.60	1.60
EJ	470	47	±20	1kHz	180	1.40	1.40
EK	560	56	±20	1kHz	205	1.30	1.30
EL	680	68	±20	1kHz	340	1.05	1.10
EM	820	82	±20	1kHz	485	0.90	0.90
FA	101	100	±20	1kHz	510	0.80	0.85

DATA LIST (C8-K4L Series)

C8-K4L (Height : 4mm max.)

Item	Stamp	Inductance			DCR (mΩ) typ.	DC Current (A)	
		(μH)	Tolerance (%)	Test Freq. (kHz)		Inductance -10% typ.	Temp. Δ25K typ.
DA	1R0	1.0	±30	1kHz	10	7.00	-
DC	1R5	1.5	±30	1kHz	12	6.50	-
DE	2R2	2.2	±30	1kHz	14	5.60	-
DF	2R7	2.7	±30	1kHz	16	5.20	-
DH	3R9	3.9	±30	1kHz	18	4.30	-
DJ	4R7	4.7	±30	1kHz	21	4.20	-
DK	5R6	5.6	±30	1kHz	23	4.10	-
DL	6R8	6.8	±30	1kHz	28	3.50	-
DM	8R2	8.2	±30	1kHz	33	3.10	-
EA	100	10	±20	1kHz	38	2.70	-
EB	120	12	±20	1kHz	44	2.60	-
EC	150	15	±20	1kHz	50	2.30	-
ED	180	18	±20	1kHz	54	2.20	-
EE	220	22	±20	1kHz	78	1.90	-
EF	270	27	±20	1kHz	89	1.50	-
EG	330	33	±20	1kHz	111	1.40	-
EH	390	39	±20	1kHz	121	1.30	-
EJ	470	47	±20	1kHz	142	1.20	-
EK	560	56	±20	1kHz	155	1.10	-
EL	680	68	±20	1kHz	200	1.05	-
EM	820	82	±20	1kHz	250	1.00	-
FA	101	100	±20	1kHz	310	0.95	-
FB	121	120	±20	1kHz	341	0.82	-
FC	151	150	±20	1kHz	421	0.73	-

DATA LIST (C8-K5L Series)

C8-K5L (Height : 5mm max.)

Item	Stamp	Inductance			DCR (mΩ) typ.	DC Current (A)	
		(μH)	Tolerance (%)	Test Freq. (kHz)		Inductance -10% typ.	Temp. Δ25K typ.
DC	1R5	1.5	±30	1kHz	12	6.50	-
DE	2R2	2.2	±30	1kHz	14	5.60	-
DF	2R7	2.7	±30	1kHz	16	5.20	-
DH	3R9	3.9	±30	1kHz	18	4.30	-
DJ	4R7	4.7	±30	1kHz	20	4.20	-
DK	5R6	5.6	±30	1kHz	22	4.10	-
DL	6R8	6.8	±30	1kHz	26	3.50	-
DM	8R2	8.2	±30	1kHz	28	3.10	-
EA	100	10	±20	1kHz	31	2.70	-
EB	120	12	±20	1kHz	34	2.60	-
EC	150	15	±20	1kHz	40	2.30	-
ED	180	18	±20	1kHz	46	2.20	-
EE	220	22	±20	1kHz	53	1.90	-
EF	270	27	±20	1kHz	64	1.50	-
EG	330	33	±20	1kHz	74	1.40	-
EH	390	39	±20	1kHz	86	1.30	-
EJ	470	47	±20	1kHz	100	1.20	-
EK	560	56	±20	1kHz	128	1.10	-
EL	680	68	±20	1kHz	150	1.05	-
EM	820	82	±20	1kHz	174	1.00	-
FA	101	100	±20	1kHz	209	0.95	-
FB	121	120	±20	1kHz	260	0.82	-
FC	151	150	±20	1kHz	348	0.73	-

DATA LIST (C8-K5LA Series)

C8-K5LA (Height : 5mm max.)

Item	Stamp	Inductance			DCR (mΩ) typ.	DC Current (A)	
		(μH)	Tolerance (%)	Test Freq. (kHz)		Inductance -30% typ.	Temp. Δ40K typ.
DB	1R2	1.2	±30	1kHz	11	10.3	7.00
DD	1R8	1.8	±30	1kHz	12	9.00	6.20
DE	2R2	2.2	±30	1kHz	16	7.50	5.80
DG	3R3	3.3	±30	1kHz	19	6.80	5.00
DH	3R9	3.9	±30	1kHz	25	5.70	4.30
DJ	4R7	4.7	±30	1kHz	27	5.50	4.00
DK	5R6	5.6	±30	1kHz	35	4.80	3.50
DL	6R8	6.8	±30	1kHz	38	4.50	3.30
DM	8R2	8.2	±30	1kHz	42	4.20	3.10
EA	100	10	±20	1kHz	55	3.60	2.80
EB	120	12	±20	1kHz	60	3.40	2.70
EC	150	15	±20	1kHz	65	3.20	2.60
ED	180	18	±20	1kHz	77	2.80	2.30
EE	220	22	±20	1kHz	88	2.60	2.20
EF	270	27	±20	1kHz	112	2.40	1.90
EG	330	33	±20	1kHz	124	2.20	1.70
EH	390	39	±20	1kHz	134	2.10	1.60
EJ	470	47	±20	1kHz	160	1.80	1.50
EK	560	56	±20	1kHz	226	1.60	1.30
EL	680	68	±20	1kHz	250	1.50	1.10
EM	820	82	±20	1kHz	317	1.40	1.05
FA	101	100	±20	1kHz	352	1.30	0.95
FB	121	120	±20	1kHz	392	1.20	0.90
FC	151	150	±20	1kHz	438	1.10	0.85

DATA LIST (C10-K3L Series)

C10-K3L (Height : 3mm max.)

Item	Stamp	Inductance			DCR (mΩ) typ.	DC Current (A)	
		(μH)	Tolerance (%)	Test Freq. (kHz)		Inductance -10% typ.	Temp. Δ40K typ.
DB	1R2	1.2	±30	1kHz	16	6.20	5.40
DD	1R8	1.8	±30	1kHz	21	5.60	4.80
DF	2R7	2.7	±30	1kHz	27	4.90	4.30
DH	3R9	3.9	±30	1kHz	29	4.30	3.70
DJ	4R7	4.7	±30	1kHz	35	3.90	3.60
DK	5R6	5.6	±30	1kHz	43	3.60	3.30
DM	8R2	8.2	±30	1kHz	48	3.20	3.20
EA	100	10	±20	1kHz	52	2.90	2.80
EB	120	12	±20	1kHz	68	2.60	2.60
EC	150	15	±20	1kHz	79	2.35	2.30
ED	180	18	±20	1kHz	98	2.20	2.25
EE	220	22	±20	1kHz	101	2.00	1.95
EF	270	27	±20	1kHz	131	1.85	1.80
EG	330	33	±20	1kHz	147	1.70	1.80
EH	390	39	±20	1kHz	194	1.55	1.75
EJ	470	47	±20	1kHz	219	1.40	1.65
EK	560	56	±20	1kHz	303	1.35	1.40
EL	680	68	±20	1kHz	346	1.20	1.30
EM	820	82	±20	1kHz	373	1.10	0.95
FA	101	100	±20	1kHz	490	0.95	0.90
FB	121	120	±20	1kHz	560	0.85	0.85
FC	151	150	±20	1kHz	696	0.70	0.70

DATA LIST (C10-K4L Series)

C10-K4L (Height : 4mm max.)

Item	Stamp	Inductance			DCR (mΩ) typ.	DC Current (A)	
		(μH)	Tolerance (%)	Test Freq. (kHz)		Inductance -10% typ.	Temp. Δ25K typ.
DA	1R0	1.0	±30	1kHz	11	7.10	-
DC	1R5	1.5	±30	1kHz	13	5.40	-
DE	2R2	2.2	±30	1kHz	16	5.30	-
DG	3R3	3.3	±30	1kHz	18	4.90	-
DJ	4R7	4.7	±30	1kHz	21	4.60	-
DK	5R6	5.6	±30	1kHz	23	4.10	-
DL	6R8	6.8	±30	1kHz	27	3.50	-
DM	8R2	8.2	±30	1kHz	30	3.30	-
EA	100	10	±30	1kHz	33	3.00	-
EB	120	12	±30	1kHz	36	2.90	-
EC	150	15	±30	1kHz	39	2.60	-
ED	180	18	±30	1kHz	43	2.40	-
EE	220	22	±30	1kHz	57	2.10	-
EF	270	27	±20	1kHz	91	2.00	-
EG	330	33	±20	1kHz	103	1.80	-
EH	390	39	±20	1kHz	116	1.70	-
EJ	470	47	±20	1kHz	128	1.50	-
EK	560	56	±20	1kHz	141	1.40	-
EL	680	68	±20	1kHz	161	1.20	-
EM	820	82	±20	1kHz	213	1.10	-
FA	101	100	±20	1kHz	255	1.00	-
FB	121	120	±20	1kHz	274	0.95	-
FC	151	150	±20	1kHz	313	0.85	-

DATA LIST (C12-K4.5L Series)

C12-K4.5L (Height : 4.5mm max.)

Item	Stamp	Inductance			DCR (mΩ) typ.	DC Current (A)	
		(μH)	Tolerance (%)	Test Freq. (kHz)		Inductance -10% typ.	Temp. Δ25K typ.
DA	1R0	1.0	±30	1kHz	7	7.10	-
DC	1R5	1.5	±30	1kHz	9	6.80	-
DE	2R2	2.2	±30	1kHz	12	6.60	-
DG	3R3	3.3	±30	1kHz	15	6.40	-
DJ	4R7	4.7	±30	1kHz	18	6.20	-
DL	6R8	6.8	±30	1kHz	21	6.00	-
DM	8R2	8.2	±30	1kHz	23	5.50	-
EA	100	10	±30	1kHz	26	5.20	-
EB	120	12	±30	1kHz	40	4.00	-
EC	150	15	±30	1kHz	45	3.90	-
ED	180	18	±30	1kHz	54	3.80	-
EE	220	22	±30	1kHz	58	3.20	-
EF	270	27	±30	1kHz	71	2.80	-
EG	330	33	±20	1kHz	102	2.60	-
EH	390	39	±20	1kHz	109	2.40	-
EJ	470	47	±20	1kHz	148	2.20	-
EK	560	56	±20	1kHz	163	1.90	-
EL	680	68	±20	1kHz	211	1.80	-
EM	820	82	±20	1kHz	228	1.70	-
FA	101	100	±20	1kHz	256	1.50	-
FB	121	120	±20	1kHz	298	1.30	-
FC	151	150	±20	1kHz	430	1.20	-

DATA LIST (C12-K7.5L Series)

C12-K7.5L (Height : 7.5mm max.)

Item	Stamp	Inductance			DCR (mΩ) typ.	DC Current (A)	
		(μH)	Tolerance (%)	Test Freq. (kHz)		Inductance -30% typ.	Temp. Δ40K typ.
DA	1R0	1.0	±30	1kHz	6	23.5	12.0
DC	1R5	1.5	±30	1kHz	7	17.1	10.0
DF	2R7	2.7	±30	1kHz	9	15.5	9.00
DH	3R9	3.9	±30	1kHz	10	13.2	8.20
DJ	4R7	4.7	±30	1kHz	12	11.3	7.50
DL	6R8	6.8	±30	1kHz	13	10.1	6.80
DM	8R2	8.2	±30	1kHz	15	8.55	6.30
EA	100	10	±20	1kHz	18	7.55	5.80
EB	120	12	±20	1kHz	20	7.10	5.60
EC	150	15	±20	1kHz	21	6.50	5.40
ED	180	18	±20	1kHz	23	6.15	5.20
EE	220	22	±20	1kHz	26	5.75	5.00
EF	270	27	±20	1kHz	33	4.65	4.20
EG	330	33	±20	1kHz	41	4.50	3.80
EH	390	39	±20	1kHz	43	4.25	3.60
EJ	470	47	±20	1kHz	57	3.90	3.30
EK	560	56	±20	1kHz	62	3.55	3.10
EL	680	68	±20	1kHz	68	3.20	2.90
EM	820	82	±20	1kHz	81	2.80	2.80
FA	101	100	±20	1kHz	91	2.55	2.60
FB	121	120	±20	1kHz	119	2.40	2.40
FC	151	150	±20	1kHz	136	2.20	2.20

DATA LIST (C13-K4.5L Series)

C13-K4.5L (Height : 4.5mm max.)

Item	Stamp	Inductance			DCR (mΩ) typ.	DC Current (A)	
		(μH)	Tolerance (%)	Test Freq. (kHz)		Inductance -10% typ.	Temp. Δ25K typ.
DA	1R0	1.0	±30	1kHz	8	11.0	-
DC	1R5	1.5	±30	1kHz	10	9.21	-
DF	2R7	2.7	±30	1kHz	13	8.23	-
DH	3R9	3.9	±30	1kHz	18	7.08	-
DJ	4R7	4.7	±30	1kHz	22	6.36	-
DL	6R8	6.8	±30	1kHz	25	5.54	-
DM	8R2	8.2	±30	1kHz	28	5.07	-
EA	100	10	±30	1kHz	32	4.61	-
EB	120	12	±30	1kHz	36	4.25	-
EC	150	15	±30	1kHz	39	3.95	-
ED	180	18	±30	1kHz	43	3.68	-
EE	220	22	±30	1kHz	51	3.23	-
EF	270	27	±30	1kHz	59	3.00	-
EG	330	33	±30	1kHz	68	2.67	-
EH	390	39	±20	1kHz	151	2.33	-
EJ	470	47	±20	1kHz	171	2.10	-
EK	560	56	±20	1kHz	187	1.99	-
EL	680	68	±20	1kHz	215	1.80	-
EM	820	82	±20	1kHz	235	1.71	-
FA	101	100	±20	1kHz	265	1.57	-
FB	121	120	±20	1kHz	296	1.44	-
FC	151	150	±20	1kHz	339	1.33	-

DIMENSIONS

C3-K Series

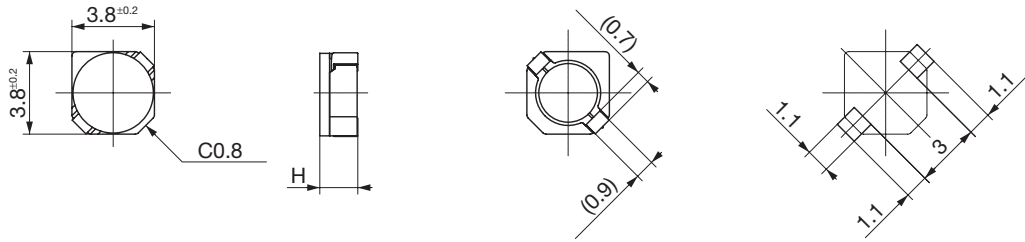

C4-K Series

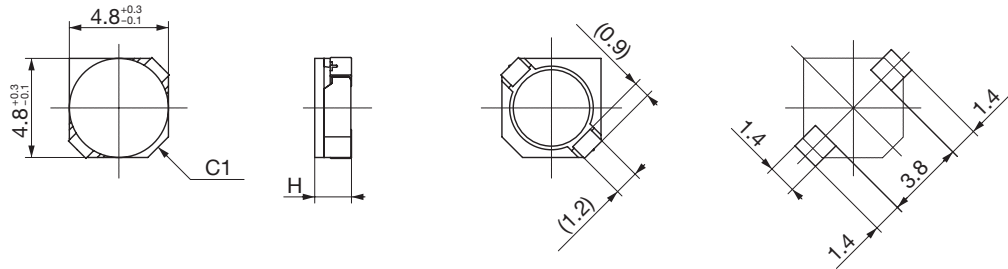

C5-K Series

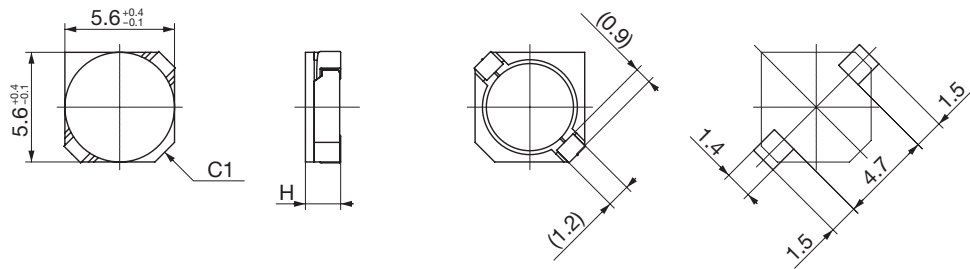

C6-K Series

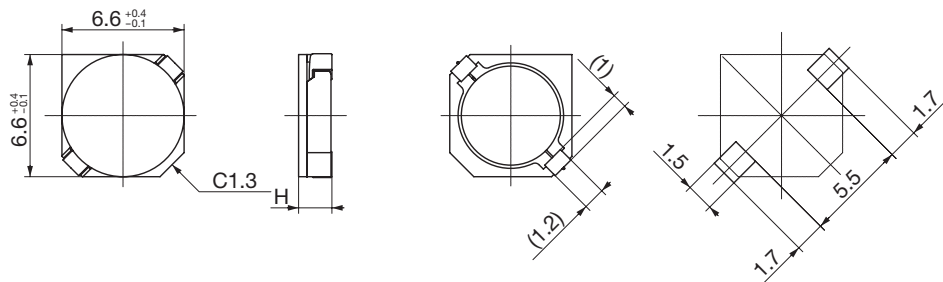

Unit : mm

C8-K Series

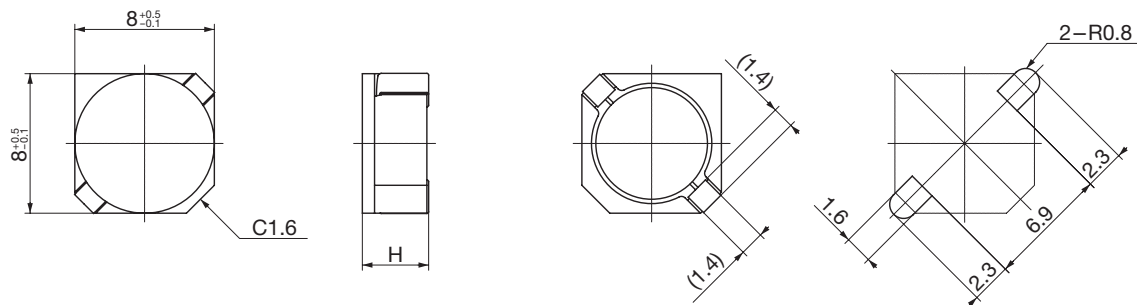

C10-K Series

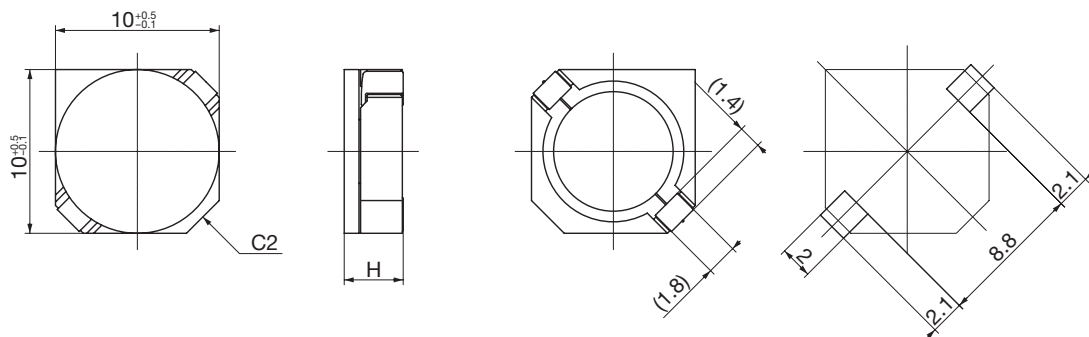

C12-K Series

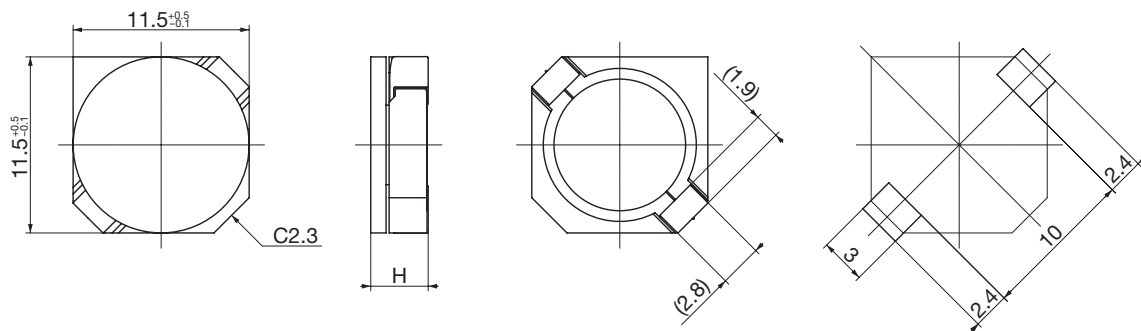

C13-K Series

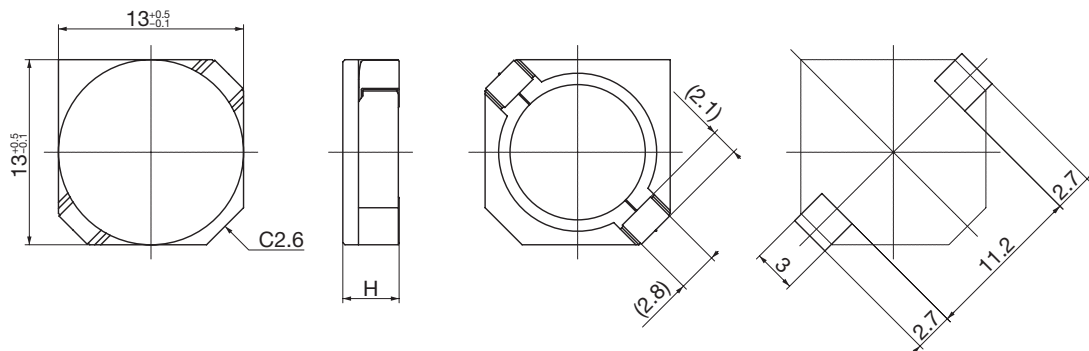

Unit : mm