

1W High Linearity and High Efficiency GaAs Power FETs

FEATURES

- 1W Typical Power at 6 GHz
- Linear Power Gain: $G_L = 13$ dB Typical at 6 GHz
- High Linearity: $IP_3 = 40$ dBm Typical at 6 GHz
- High Power Added Efficiency: Nominal PAE of 43% at 6 GHz
- Via Hole Source Ground
- Suitable for High Reliability Application
- Breakdown Voltage: $BV_{DGO} \geq 15$ V
- $L_g = 0.35$ μm , $W_g = 2.4$ mm
- Tight V_p ranges control
- High RF input power handling capability
- 100 % DC Tested

PHOTO ENLARGEMENT

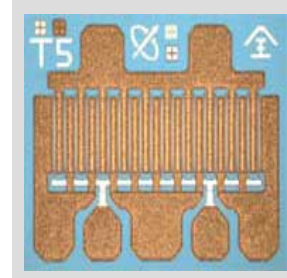

DESCRIPTION

The TC1501 is a GaAs Pseudomorphic High Electron Mobility Transistor (PHEMT) which has high linearity and high Power Added Efficiency. The device is processed with a propriety via-hole process, which provides low thermal resistance and low inductance. The short gate length enables the device to be used in circuits up to 20GHz. All devices are 100% DC tested to assure consistent quality. Bond pads are gold plated for either thermo-compression or thermo-sonic wire bonding. Backside gold plating is compatible with standard AuSn die-attach. Typical application include commercial and military high performance power amplifiers.

ELECTRICAL SPECIFICATIONS ($T_A = 25^\circ\text{C}$)

Symbol	Conditions	MIN	TYP	MAX	UNIT
P_{1dB}	Output Power at 1dB Gain Compression Point, $f = 6$ GHz $V_{DS} = 8$ V, $I_{DS} = 240$ mA	29.5	30		dBm
G_L	Linear Power Gain, $f = 6$ GHz $V_{DS} = 8$ V, $I_{DS} = 240$ mA	12	13		dB
IP_3	Intercept Point of the 3 rd -order Intermodulation, $f = 6$ GHz $V_{DS} = 8$ V, $I_{DS} = 240$ mA, $*P_{SCL} = 17$ dBm		40		dBm
PAE	Power Added Efficiency at 1dB Compression Power, $f = 6$ GHz		43		%
I_{DSS}	Saturated Drain-Source Current at $V_{DS} = 2$ V, $V_{GS} = 0$ V		600		mA
g_m	Transconductance at $V_{DS} = 2$ V, $V_{GS} = 0$ V		400		mS
V_P	Pinch-off Voltage at $V_{DS} = 2$ V, $I_D = 4.8$ mA		-1.7**		Volts
BV_{DGO}	Drain-Gate Breakdown Voltage at $I_{DGO} = 1.2$ mA	15	18		Volts
R_{th}	Thermal Resistance		12		$^\circ\text{C}/\text{W}$

Note:

* P_{SCL} : Output Power of Single Carrier Level.

**For the tight control of the pinch-off voltage. TC1501's are divided into 3 groups:

(1)TC1501P1519 : $V_p = -1.5\text{V}$ to -1.9V (2) TC1501P1620 : $V_p = -1.6\text{V}$ to -2.0V

(3)TC1501P1721 : $V_p = -1.7\text{V}$ to -2.1V In addition, the customers may specify their requirements.

ABSOLUTE MAXIMUM RATINGS (T_A=25 °C)

Symbol	Parameter	Rating
V _{DS}	Drain-Source Voltage	12 V
V _{GS}	Gate-Source Voltage	-5 V
I _{DS}	Drain Current	I _{DSS}
P _{in}	RF Input Power, CW	28 dBm
P _T	Continuous Dissipation	3.8 W
T _{CH}	Channel Temperature	175 °C
T _{STG}	Storage Temperature	- 65 °C to +175 °C

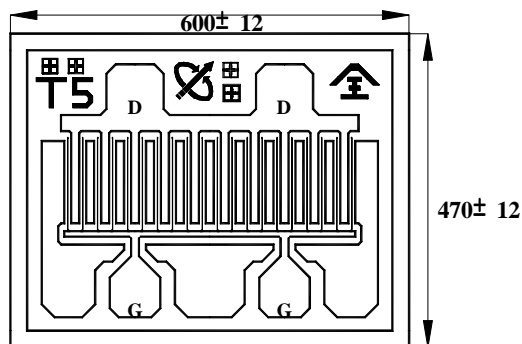
CHIP DIMENSIONS

Units: Micrometers
Chip Thickness: 50
Gate Pad: 79 x 59.5
Drain Pad: 86.0 x 76.0

CHIP HANDLING

DIE ATTACHMENT: Conductive epoxy or eutectic die attach is recommended. Eutectic die attach can be accomplished with Au-Sn (80% Au-20% Sn) perform at stage temperature: 290°C ± 5°C; Handling Tool: Tweezers; Time: less than 1min.

WIRE BONDING: The recommended wire bond method is thermocompression bonding with 0.7 to 1.0 mil (0.018 to 0.025 mm) gold wire. Stage temperature: 220°C to 250°C; Bond Tip Temperature: 150°C; Bond Force: 20 to 30 gms depending on size of wire and Bond Tip Temperature.

HANDLING PRECAUTIONS: The user must operate in a clean, dry environment. Care should be exercised during handling avoid damage to the devices. Electrostatic Discharge (ESD) precautions should be observed at all stages of storage, handling, assembly, and testing. The static discharge must be less than 300V.

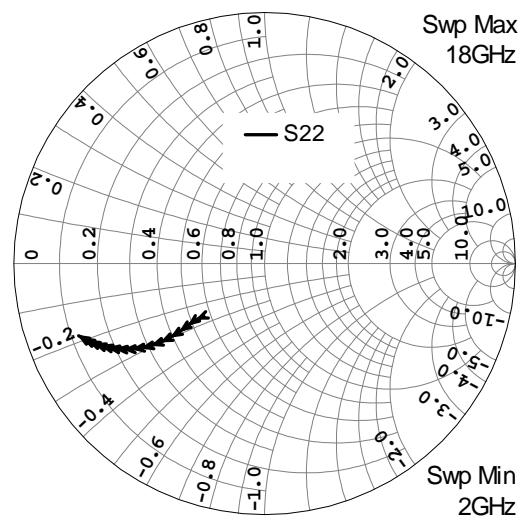
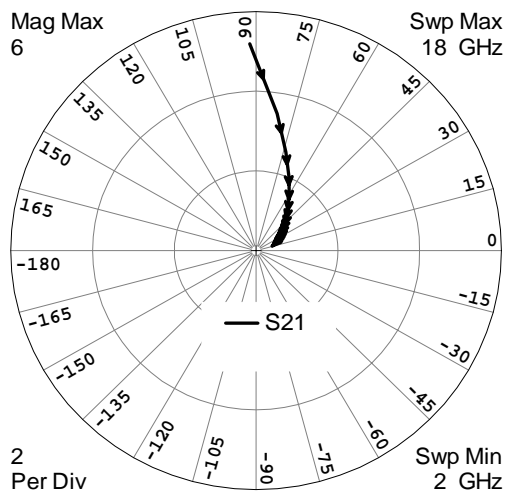
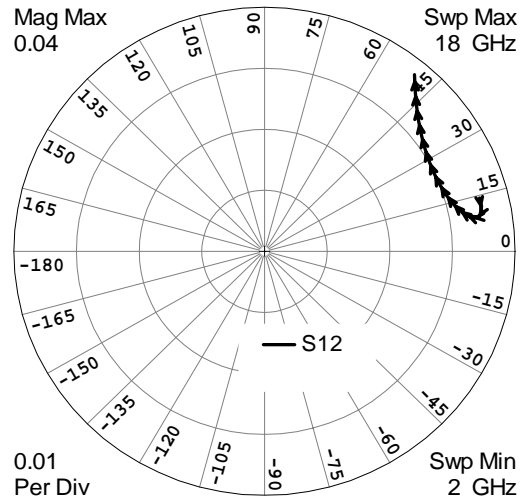
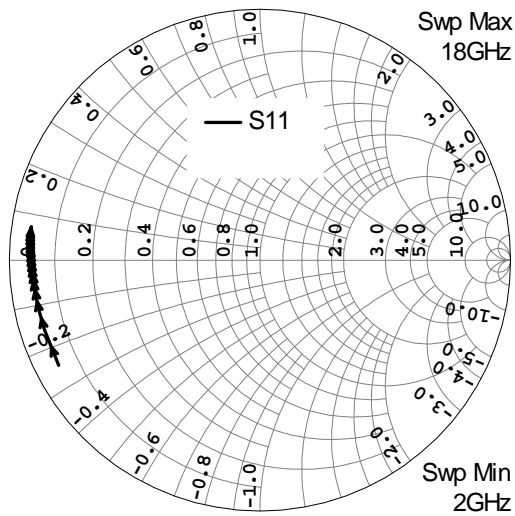
TYPICAL SCATTERING PARAMETERS (T_A=25 °C) V_{DS} = 8 V, I_{DS} = 240 mA

FREQUENCY (GHz)	S11		S21		S12		S22	
	MAG	ANG	MAG	ANG	MAG	ANG	MAG	ANG
0.05	0.99891	-11.249	22.18	173.81	0.0038131	84.101	0.20605	-13.841
0.1	0.99603	-22.286	21.835	167.74	0.0075079	78.333	0.20936	-27.208
0.2	0.98604	-43.003	20.603	156.38	0.014168	67.567	0.22045	-51.153
0.3	0.97335	-61.165	18.944	146.45	0.019538	58.24	0.23376	-70.488
0.4	0.96085	-76.492	17.175	138.1	0.023616	50.477	0.24626	-85.489
0.5	0.94996	-89.181	15.492	131.16	0.026624	44.136	0.25683	-96.998
0.6	0.94105	-99.625	13.98	125.41	0.028825	38.98	0.26545	-105.86
0.7	0.93396	-108.24	12.658	120.6	0.030443	34.77	0.27249	-112.74
0.8	0.92837	-115.4	11.516	116.54	0.031646	31.305	0.27834	-118.14
0.9	0.92397	-121.41	10.532	113.06	0.03255	28.425	0.28333	-122.42
1	0.92048	-126.49	9.6827	110.04	0.033239	26.007	0.28771	-125.84
1.1	0.91769	-130.84	8.9461	107.39	0.03377	23.955	0.29169	-128.61
1.2	0.91545	-134.59	8.3038	105.04	0.034182	22.199	0.29539	-130.85
1.3	0.91363	-137.85	7.7405	102.92	0.034505	20.683	0.29891	-132.68
1.4	0.91214	-140.71	7.2435	101	0.034758	19.364	0.30232	-134.18
1.5	0.91091	-143.24	6.8025	99.24	0.034957	18.208	0.30567	-135.42
1.6	0.90989	-145.49	6.4089	97.618	0.035113	17.19	0.30901	-136.44
1.7	0.90904	-147.5	6.0558	96.111	0.035234	16.288	0.31234	-137.28
1.8	0.90833	-149.32	5.7375	94.702	0.035326	15.485	0.3157	-137.97
1.9	0.90774	-150.96	5.4492	93.377	0.035395	14.767	0.3191	-138.54
2	0.90723	-152.45	5.187	92.124	0.035444	14.123	0.32254	-139.01
3	0.9040	-162.30	3.4748	81.52	0.0353	10.50	0.3571	-140.96
4	0.9041	-167.64	2.5798	73.64	0.0346	9.26	0.3983	-141.11
5	0.9051	-171.11	2.0300	66.87	0.0337	9.37	0.4415	-141.38
6	0.9065	-173.66	1.6573	60.79	0.0327	10.45	0.4843	-142.05
7	0.9081	-175.67	1.3879	55.24	0.0318	12.36	0.5254	-143.09
8	0.9098	-177.35	1.1843	50.12	0.0310	14.98	0.5638	-144.38
9	0.9115	-178.82	1.0254	45.38	0.0303	18.21	0.5993	-145.82
10	0.9131	-179.85	0.8983	40.99	0.0300	21.90	0.6315	-147.36
11	0.9147	-178.64	0.7947	36.92	0.0299	25.91	0.6606	-148.92
12	0.9161	-177.50	0.7090	33.15	0.0302	30.04	0.6868	-150.48
13	0.9175	-176.42	0.6371	29.65	0.0308	34.13	0.7103	-152.01
14	0.9188	-175.40	0.5762	26.40	0.0317	38.03	0.7314	-153.49
15	0.9199	-174.41	0.5241	23.40	0.0328	41.66	0.7502	-154.92
16	0.9210	-173.45	0.4791	20.62	0.0342	44.95	0.7670	-156.30
17	0.9220	-172.52	0.4400	18.05	0.0358	47.87	0.7821	-157.61
18	0.9229	-171.61	0.4058	15.67	0.0376	50.43	0.7956	-158.87

* The data does not include gate, drain and source bond wires.

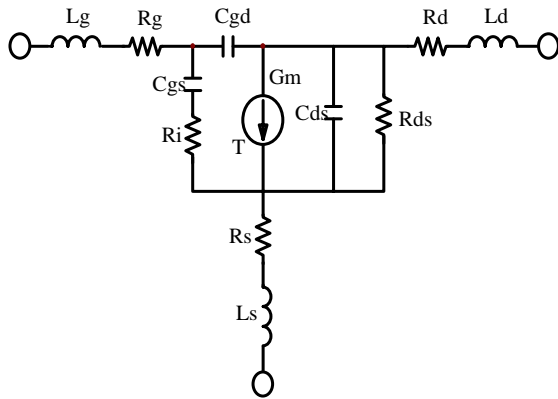
SMALL SIGNAL MODEL, $V_{DS} = 8\text{ V}$, $I_{DS} = 240\text{ mA}$
SCHEMATI

PARAMETERS

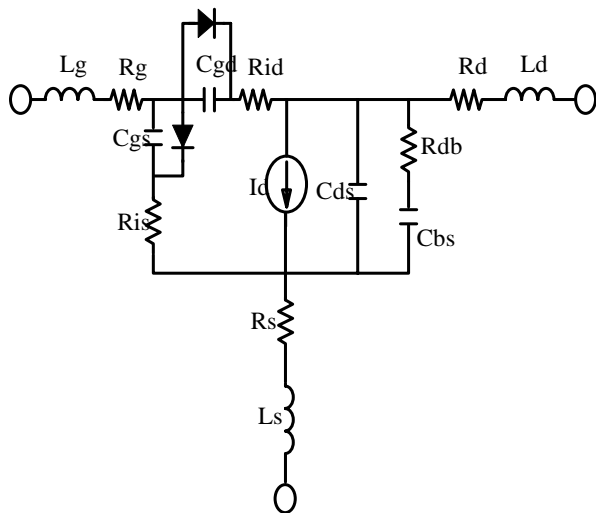
Lg	0.039 nH	Rs	0.394 Ohm
Rg	0.45 Ohm	Ls	0.01 nH
Cgs	4.435 pF	Cds	0.536 pF
Ri	0.91 Ohm	Rds	63.7 Ohm
Cgd	0.181 pF	Rd	0.63 Ohm
Gm	440.3 mS	Ld	0.008 nH
T	3.9 psec		

LARGE SIGNAL MODEL, $V_{DS} = 8\text{ V}$, $I_{DS} = 240\text{ mA}$
SCHEMATI

TOM2 MODEL PARAMETERS

VTO	-1.768 V	VMAX	0.5 V
ALPHA	2.81	CGD	0.1805 pF
BETA	0.549	CGS	7.22 pF
GAMMA	0.0173	CDS	0.5364 pF
DELTA	0.0818	RIS	0.908 Ohm
Q	0.96	RID	0.0001 Ohm
NG	0.1	VBR	15 V
ND	0.01	RDB	46.517 Ohm
TAU	3.9 ps	CBS	9.6833 pF
RG	0.454 Ohm	TNOM	25 °C
RD	0.63 Ohm	LS	0.0101 nH
RS	0.394 Ohm	LG	0.0391 nH
IS	1E-11 mA	LD	0.008 nH
N	1	AFAC	1
VBI	1 V	NFING	1
VDELTA	0.2 V		