

## FUJI POWER MOSFET Super FAP-G Series

### N-CHANNEL SILICON POWER MOSFET

#### ■ Outline Drawings

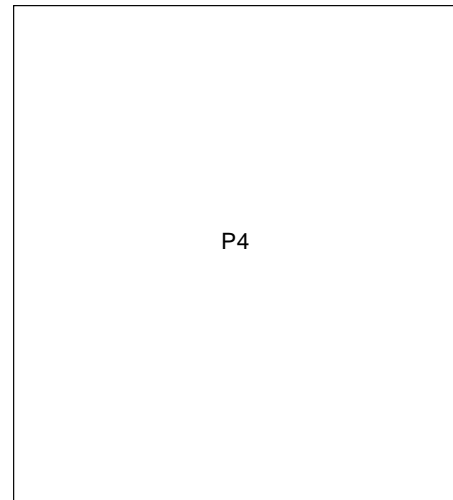

#### ■ Features

- High speed switching
- Low on-resistance
- No secondary breakdown
- Low driving power
- Avalanche-proof

#### ■ Applications

- Switching regulators
- UPS (Uninterruptible Power Supply)
- DC-DC converters

#### ■ Maximum ratings and characteristic Absolute maximum ratings

● (Tc=25°C unless otherwise specified)

Item	Symbol	Ratings	Unit
Drain-source voltage	V <sub>DS</sub>	500	V
Continuous drain current	I <sub>D</sub>	±12	A
Pulsed drain current	I <sub>D(puls)</sub>	±48	A
Gate-source voltage	V <sub>GS</sub>	±30	V
Repetitive or non-repetitive	IAR *2	12	A
Maximum Avalanche Energy	EAS*1	217	mJ
Maximum Drain-Source dV/dt	dV <sub>DS</sub> /dt *4	20	kV/μs
Peak Diode Recovery dV/dt	dV/dt *3	5	kV/μs
Max. power dissipation	P <sub>D</sub>	T <sub>a</sub> =25°C	1.67
		T <sub>c</sub> =25°C	95
Operating and storage temperature range	T <sub>ch</sub>	+150	°C
	T <sub>stg</sub>	-55 to +150	°C

\*1 L=2.77mH, V<sub>CC</sub>=50V \*2 T<sub>ch</sub>≤150°C \*3 I<sub>F</sub>≤-I<sub>D</sub>, -di/dt=50A/μs, V<sub>CC</sub>≤BV<sub>DSS</sub>, T<sub>ch</sub>≤150°C

\*4 V<sub>DS</sub>≤500V

#### ■ Equivalent circuit schematic

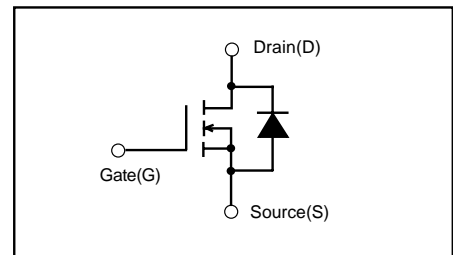

#### ● Electrical characteristics (Tc =25°C unless otherwise specified)

Item	Symbol	Test Conditions	Min.	Typ.	Max.	Units
Drain-source breakdown voltage	V <sub>(BR)DSS</sub>	I <sub>D</sub> =250μA V <sub>GS</sub> =0V	500			V
Gate threshold voltage	V <sub>GS(th)</sub>	I <sub>D</sub> =250μA V <sub>DS</sub> =V <sub>GS</sub>	3.0		5.0	V
Zero gate voltage drain current	I <sub>DSS</sub>	V <sub>DS</sub> =500V V <sub>GS</sub> =0V V <sub>DS</sub> =400V V <sub>GS</sub> =0V	T <sub>ch</sub> =25°C		25	μA
			T <sub>ch</sub> =125°C		250	
Gate-source leakage current	I <sub>GSS</sub>	V <sub>GS</sub> =±30V V <sub>DS</sub> =0V		10	100	nA
Drain-source on-state resistance	R <sub>DS(on)</sub>	I <sub>D</sub> =6A V <sub>GS</sub> =10V		0.40	0.52	Ω
Forward transconductance	g <sub>fs</sub>	I <sub>D</sub> =6A V <sub>DS</sub> =25V	5.5	11		S
Input capacitance	C <sub>iss</sub>	V <sub>DS</sub> =25V V <sub>GS</sub> =0V f=1MHz		1200	1800	pF
Output capacitance	C <sub>oss</sub>			140	210	
Reverse transfer capacitance	C <sub>rss</sub>			6.0	9.0	
Turn-on time t <sub>on</sub>	td(on)	V <sub>CC</sub> =300V I <sub>D</sub> =6A V <sub>GS</sub> =10V		17	26	ns
	tr			15	23	
Turn-off time t <sub>off</sub>	td(off)	R <sub>GS</sub> =10Ω		34	51	
	tf			7	11	
Total Gate Charge	Q <sub>G</sub>	V <sub>CC</sub> =250V		30	45	nC
Gate-Source Charge	Q <sub>GS</sub>	I <sub>D</sub> =12A		11	16.5	
Gate-Drain Charge	Q <sub>GD</sub>	V <sub>GS</sub> =10V		10	15	
Avalanche capability	I <sub>AV</sub>	L=2.77mH T <sub>ch</sub> =25°C	12			A
Diode forward on-voltage	V <sub>SD</sub>	I <sub>F</sub> =12A V <sub>GS</sub> =0V T <sub>ch</sub> =25°C		1.00	1.50	V
Reverse recovery time	t <sub>rr</sub>	I <sub>F</sub> =12A V <sub>GS</sub> =0V		0.7		μs
Reverse recovery charge	Q <sub>rr</sub>	-di/dt=100A/μs T <sub>ch</sub> =25°C		4.5		μC

#### ● Thermal characteristics

Item	Symbol	Test Conditions	Min.	Typ.	Max.	Units
Thermal resistance	R <sub>th(ch-c)</sub>	channel to case			1.32	°C/W
	R <sub>th(ch-a)</sub>	channel to ambient			75.0	°C/W

Characteristics

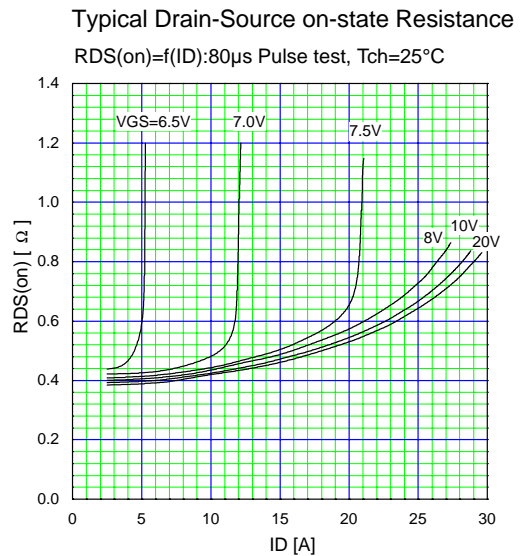
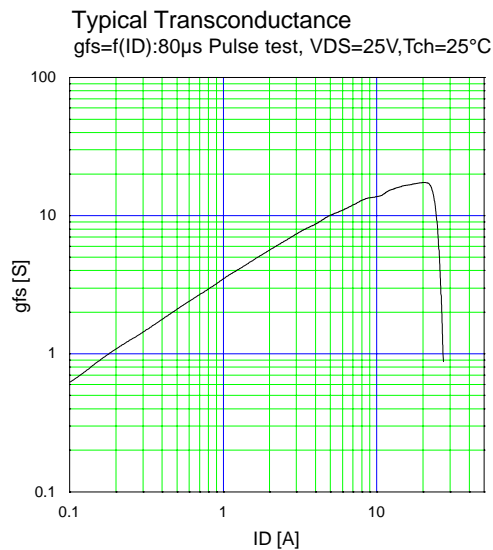
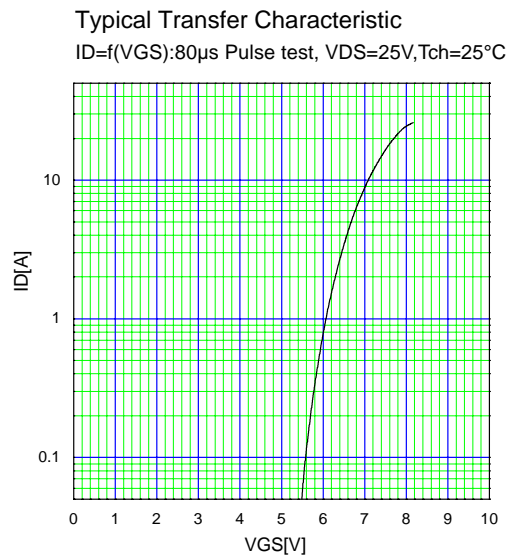
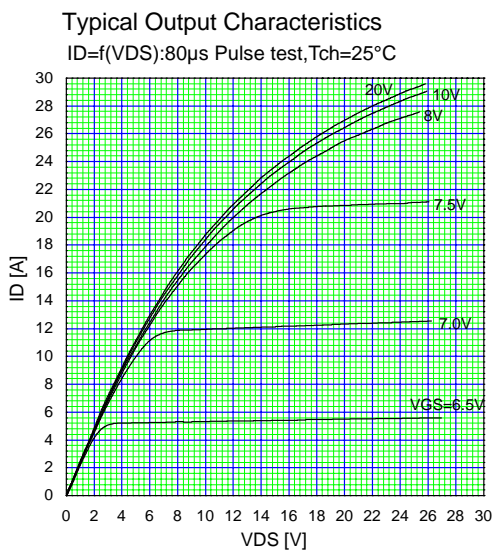
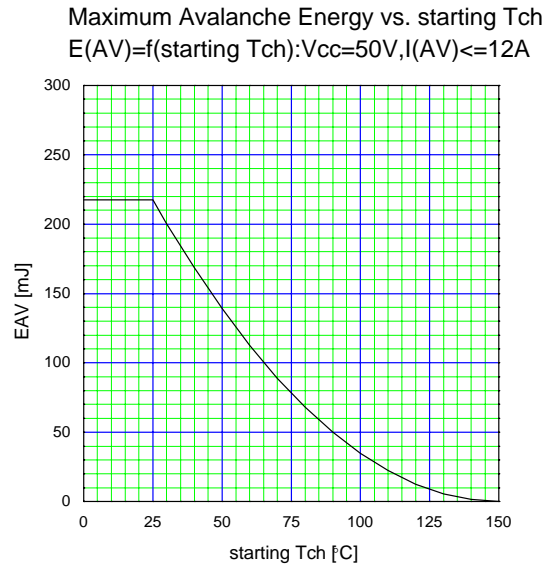
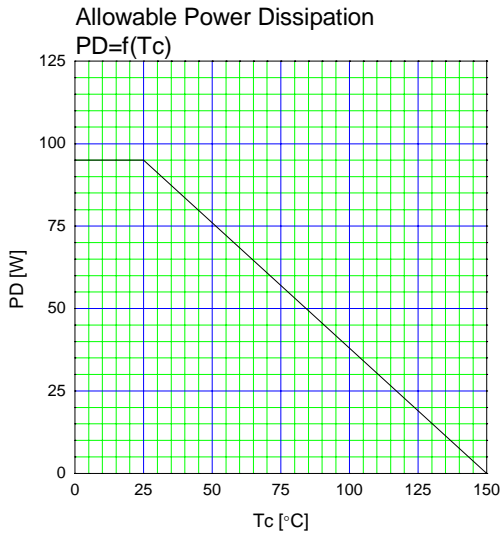

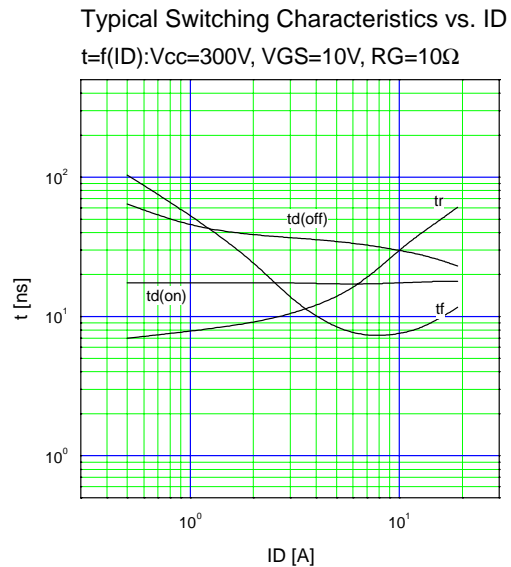
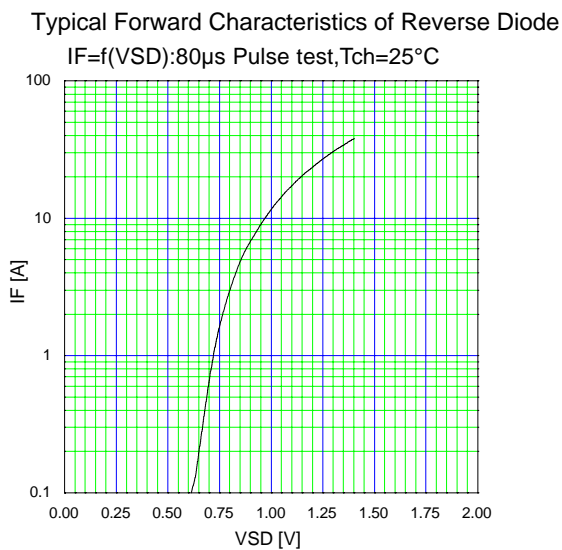
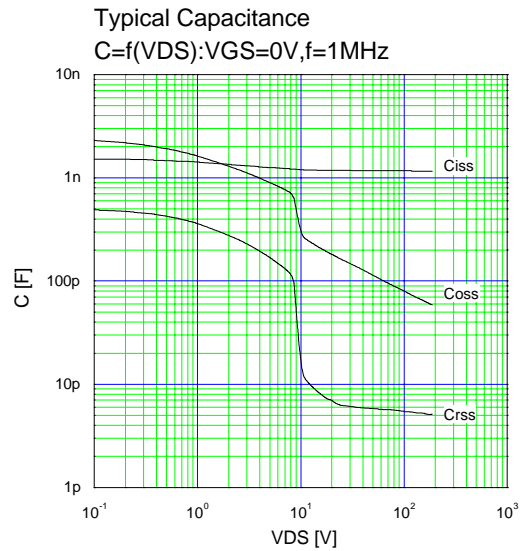
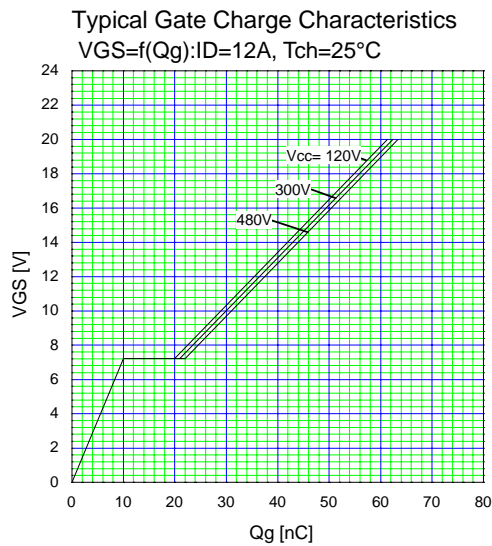
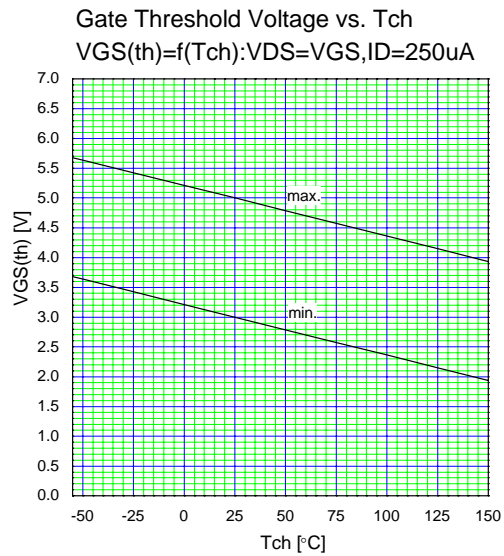
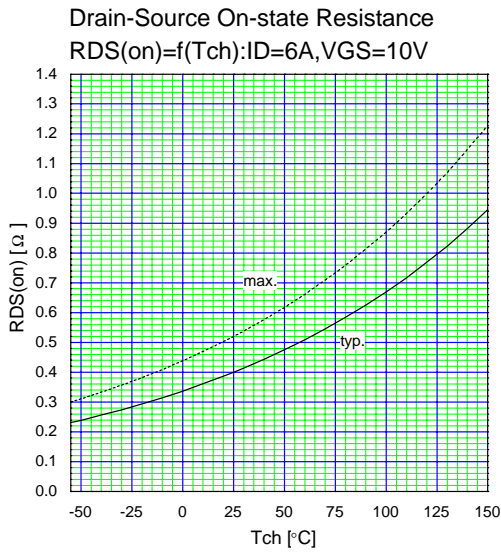

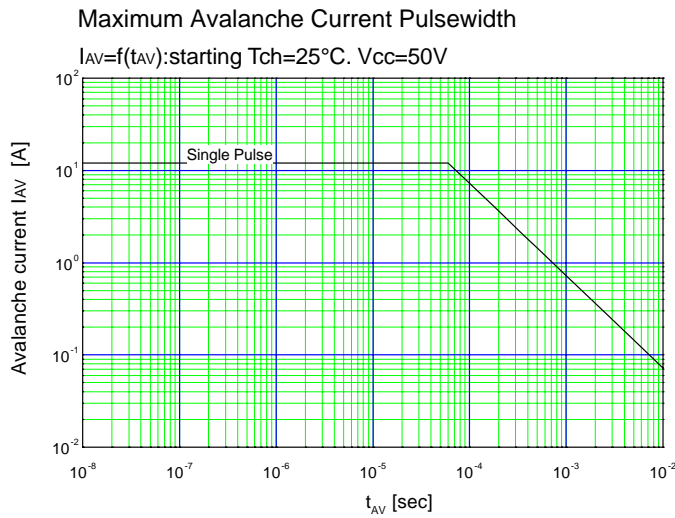
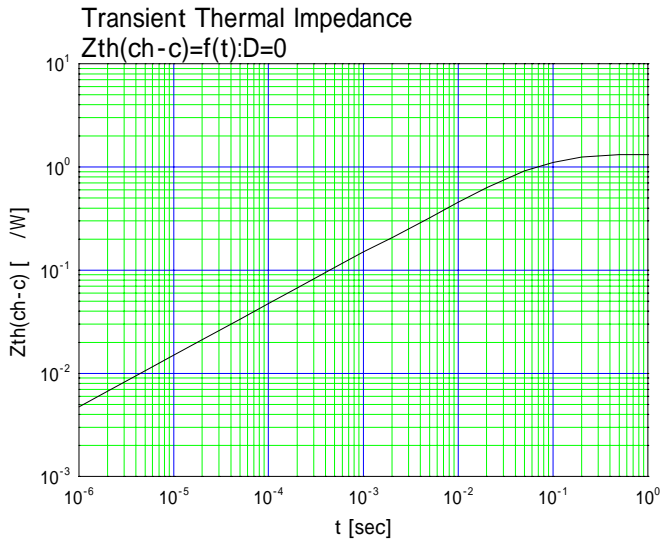

■ Outline Drawings (mm)

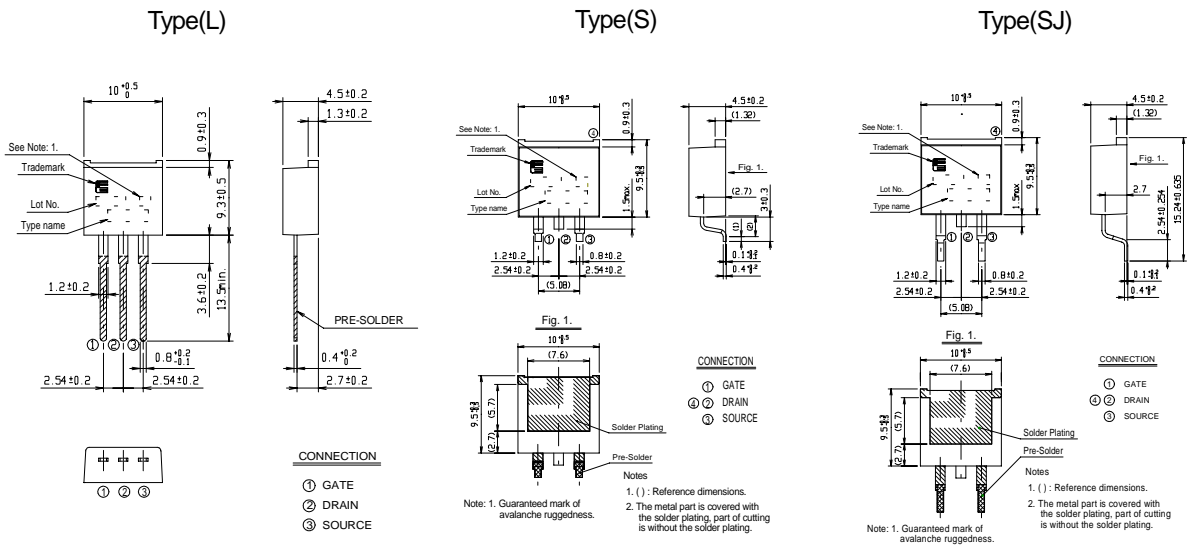

Note: 1. Guaranteed mark of avalanche ruggedness.