

Dual N-Channel 30-V (D-S) MOSFET with Schottky Diode

PRODUCT SUMMARY			
	V _{DS} (V)	r _{DS(on)} (Ω)	I _D (A)
Channel-1	30	0.011 @ V _{GS} = 10 V	10
		0.016 @ V _{GS} = 4.5 V	8.2
Channel-2		0.0085 @ V _{GS} = 10 V	14
		0.0095 @ V _{GS} = 4.5 V	13

SCHOTTKY PRODUCT SUMMARY		
V _{DS} (V)	V _{SD} (V) Diode Forward Voltage	I _F (A)
30	0.53 V @ 3 A	2.0

FEATURES

- TrenchFET® Power MOSFET
- 100% R_g Tested

APPLICATIONS

- DC/DC Converters
 - Game Stations
 - Video Equipment

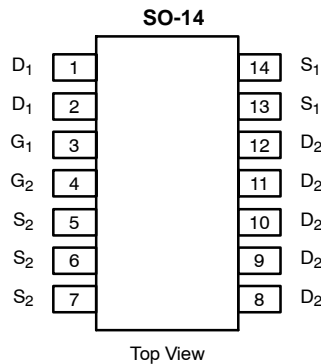

Ordering Information:
Si4310BDY—E3
Si4310BDY-T1—E3 (with Tape and Reel)

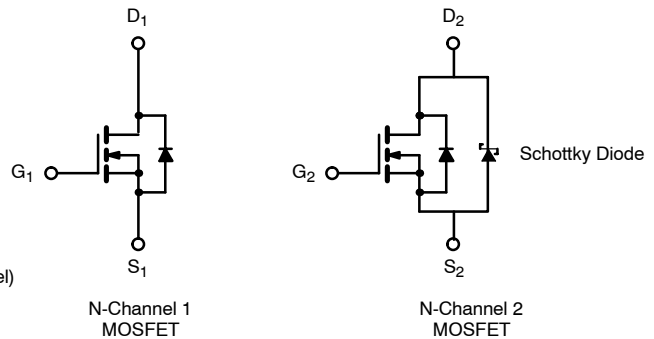

ABSOLUTE MAXIMUM RATINGS (T _A = 25 °C UNLESS OTHERWISE NOTED)							
Parameter	Symbol	Channel-1		Channel-2		Unit	
		10 secs	Steady State	10 secs	Steady State		
Drain-Source Voltage	V _{DS}	30				V	
Gate-Source Voltage	V _{GS}	± 20		± 20			
Continuous Drain Current (T _J = 150 °C) ^a	I _D	T _A = 25 °C	10	7.5	14	9.8	A
		T _A = 70 °C	8	6	11	7.8	
Pulsed Drain Current	I _{DM}	40		50		A	
Continuous Source Current (Diode Conduction) ^a	I _S	1.8	1.04	2.73	1.33		
Maximum Power Dissipation ^a	P _D	T _A = 25 °C	2	1.14	3.0	1.47	W
		T _A = 70 °C	1.28	0.73	1.9	0.94	
Operating Junction and Storage Temperature Range	T _J , T _{stg}	-55 to 150				°C	

THERMAL RESISTANCE RATINGS									
Parameter	Symbol	Channel-1		Channel-2		Schottky		Unit	
		Typ	Max	Typ	Max	Typ	Max		
Maximum Junction-to-Ambient ^a	R _{thJA}	t ≤ 10 sec	53	62.5	34	35	40	48	°C/W
		Steady-State	92	110	70	72	76	93	
Maximum Junction-to-Foot (Drain)	R _{thJF}	Steady-State	35	42	17	24	21	26	

Notes

a. Surface Mounted on 1" x 1" FR4 Board.

MOSFET SPECIFICATIONS ($T_J = 25^\circ\text{C}$ UNLESS OTHERWISE NOTED).									
Parameter	Symbol	Test Condition	Min	Typ ^a	Max	Unit			
Static									
Gate Threshold Voltage	$V_{GS(th)}$	$V_{DS} = V_{GS}, I_D = 250\ \mu\text{A}$	Ch-1	1.0		3.0	V		
			Ch-2	1.0		3.0			
Gate-Body Leakage	I_{GSS}	$V_{DS} = 0\ \text{V}, V_{GS} = \pm 20\ \text{V}$	Ch-1			100	nA		
			Ch-2			100			
Zero Gate Voltage Drain Current	I_{DSS}	$V_{DS} = 30\ \text{V}, V_{GS} = 0\ \text{V}$	Ch-1			1	μA		
			Ch-2			100			
		$V_{DS} = 30\ \text{V}, V_{GS} = 0\ \text{V}, T_J = 85^\circ\text{C}$	Ch-1			15			
			Ch-2			4000			
On-State Drain Current ^b	$I_{D(on)}$	$V_{DS} = 5\ \text{V}, V_{GS} = 10\ \text{V}$	Ch-1	20			A		
			Ch-2	30					
Drain-Source On-State Resistance ^b	$r_{DS(on)}$	$V_{GS} = 10\ \text{V}, I_D = 10\ \text{A}$	Ch-1		0.009	0.011	Ω		
		$V_{GS} = 10\ \text{V}, I_D = 14\ \text{A}$	Ch-2		0.0065	0.0085			
		$V_{GS} = 4.5\ \text{V}, I_D = 8.2\ \text{A}$	Ch-1		0.013	0.016			
		$V_{GS} = 4.5\ \text{V}, I_D = 13\ \text{A}$	Ch-2		0.0075	0.0095			
Forward Transconductance ^b	g_{fs}	$V_{DS} = 15\ \text{V}, I_D = 10\ \text{A}$	Ch-1		30		S		
		$V_{DS} = 15\ \text{V}, I_D = 14\ \text{A}$	Ch-2		60				
Diode Forward Voltage ^b	V_{SD}	$I_S = 1.8\ \text{A}, V_{GS} = 0\ \text{V}$	Ch-1		0.76	1.1	V		
		$I_S = 2.73\ \text{A}, V_{GS} = 0\ \text{V}$	Ch-2		0.485	0.53			
Dynamic^a									
Input Capacitance	C_{iss}	$V_{DS} = 15\ \text{V}, V_{GS} = 0\ \text{V}, f = 1\ \text{MHz}$	Ch-1	790	1580	2370	pF		
			Ch-2	1530	3060	4590			
Output Capacitance	C_{oss}		Ch-1	145	290	435			
			Ch-2	300	600	900			
Reverse Transfer Capacitance	C_{rss}		Ch-1	70	140	210			
			Ch-2	115	225	340			
Total Gate Charge	Q_g		Channel-1 $V_{DS} = 15\ \text{V}, V_{GS} = 4.5\ \text{V}, I_D = 10\ \text{A}$ Channel-2 $V_{DS} = 15\ \text{V}, V_{GS} = 4.5\ \text{V}, I_D = 14\ \text{A}$	Ch-1		12		18	nC
Gate-Source Charge	Q_{gs}			Ch-2		19		30	
		Ch-1			5.3				
Gate-Drain Charge	Q_{gd}	Ch-2			10				
		Ch-1			4.3				
Ch-2		5							
Gate Resistance	R_g	$f = 1\ \text{MHz}$	Ch-1	0.90	1.8	2.7	Ω		
			Ch-2	0.3	0.95	1.4			
Turn-On Delay Time	$t_{d(on)}$	Channel-1 $V_{DD} = 15\ \text{V}, R_L = 15\ \Omega$ $I_D \cong 1\ \text{A}, V_{GEN} = 10\ \text{V}, R_G = 6\ \Omega$ Channel-2 $V_{DD} = 15\ \text{V}, R_L = 15\ \Omega$ $I_D \cong 1\ \text{A}, V_{GEN} = 10\ \text{V}, R_G = 6\ \Omega$	Ch-1		13	20	ns		
			Ch-2		17	26			
Rise Time	t_r		Ch-1		10	15			
			Ch-2		12	20			
Turn-Off Delay Time	$t_{d(off)}$		Ch-1		33	50			
			Ch-2		53	80			
Fall Time	t_f		Ch-1		10	15			
			Ch-2		17	26			
Source-Drain Reverse Recovery Time	t_{rr}	$I_F = 1.8\ \text{A}, di/dt = 100\ \text{A}/\mu\text{s}$	Ch-1		25	40			
		$I_F = 2.73\ \text{A}, di/dt = 100\ \mu\text{A}/\mu\text{s}$	Ch-2		31	50			

Notes

- a. Guaranteed by design, not subject to production testing.
 b. Pulse test; pulse width $\leq 300\ \mu\text{s}$, duty cycle $\leq 2\%$.



SCHOTTKY SPECIFICATIONS (T _J = 25°C UNLESS OTHERWISE NOTED)						
Parameter	Symbol	Test Condition	Min	Typ	Max	Unit
Forward Voltage Drop	V _F	I _F = 3 A		0.485	0.53	V
		I _F = 3 A, T _J = 125°C		0.42	0.42	
Maximum Reverse Leakage Current	I _{rm}	V _r = 30 V		0.008	0.100	mA
		V _r = 30 V, T _J = 75°C		0.4	5	
		V _r = -30 V, T _J = 125°C		6.5	20	
Junction Capacitance	C _T	V _r = 15 V		102		pF

TYPICAL CHARACTERISTICS (25°C UNLESS NOTED) CHANNEL-1

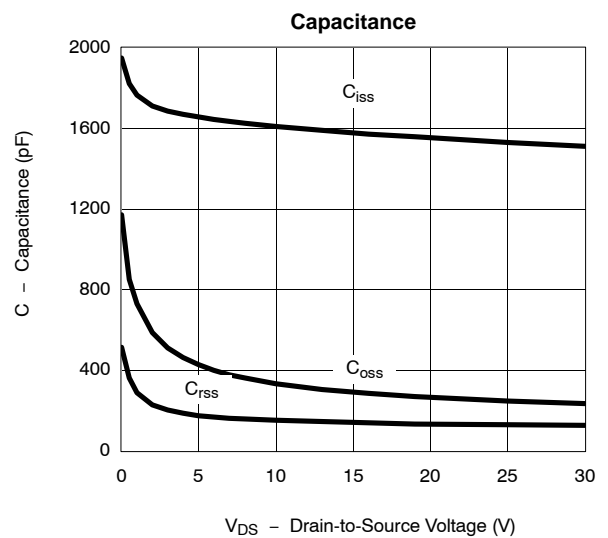
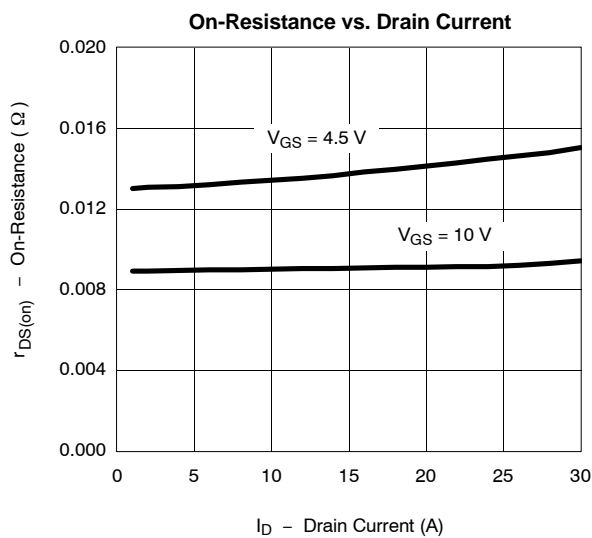
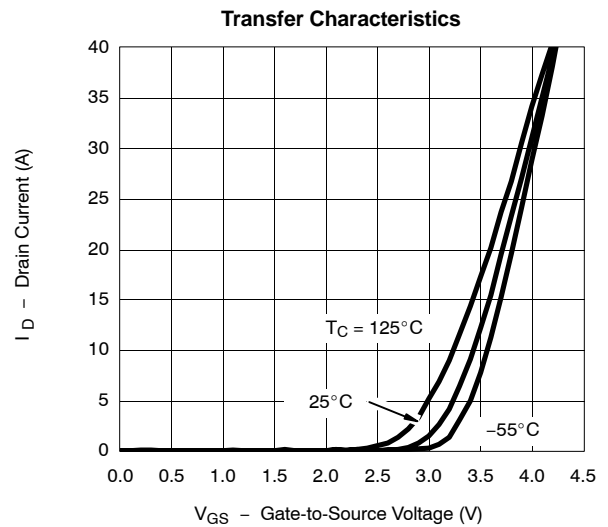
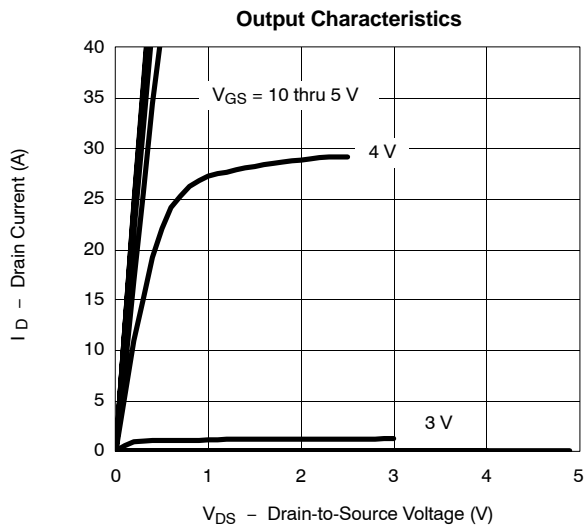

TYPICAL CHARACTERISTICS (25 °C UNLESS NOTED)

CHANNEL-1

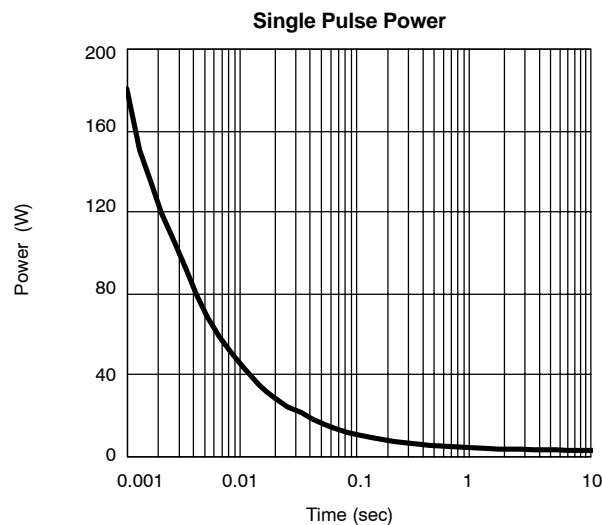
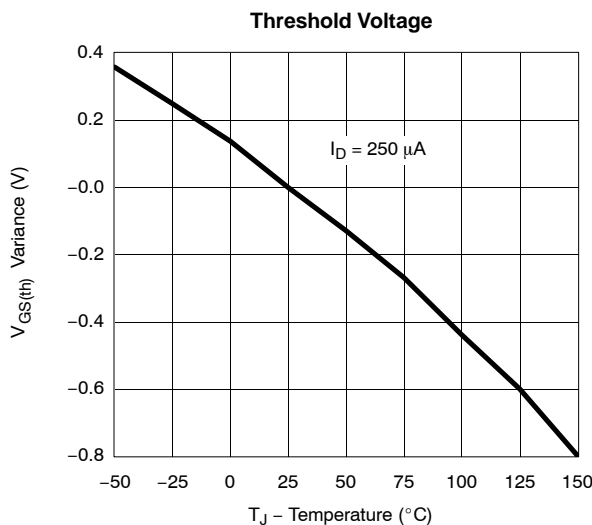
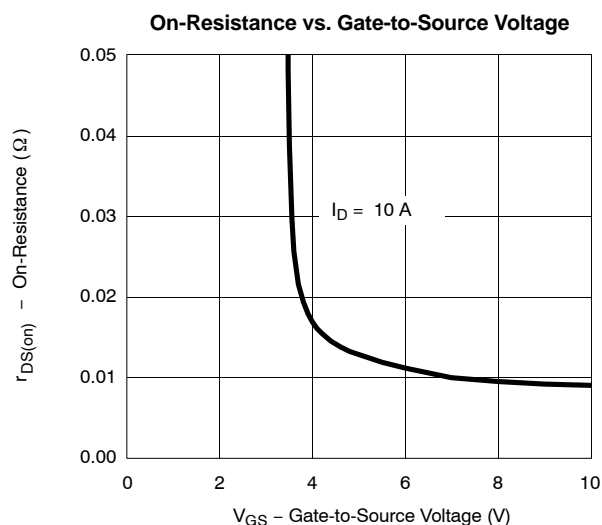
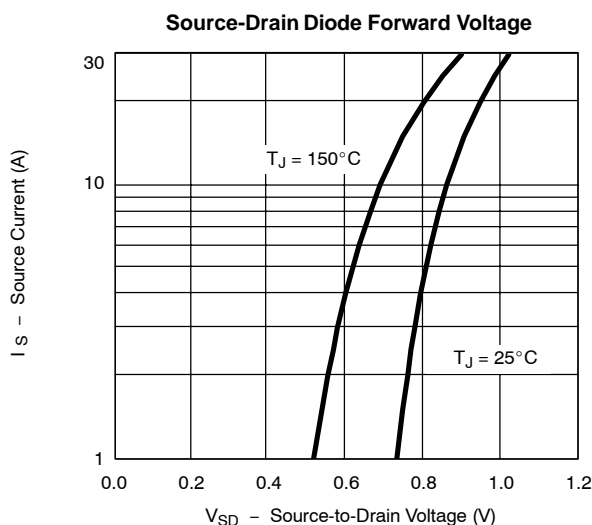
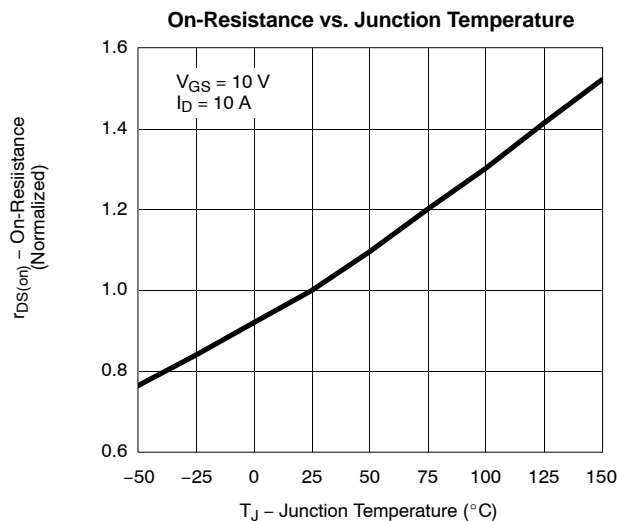
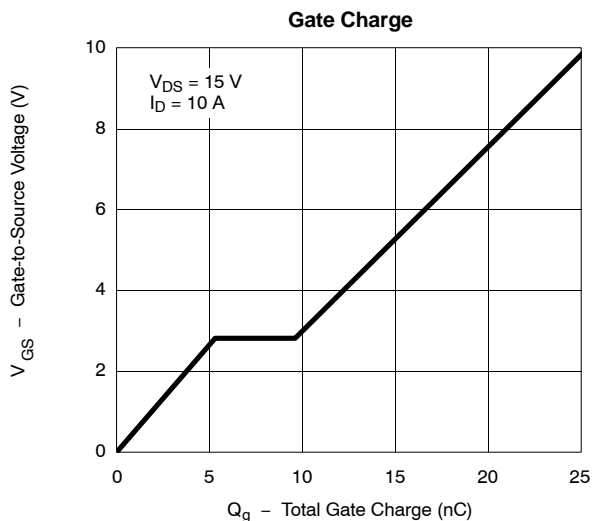



TYPICAL CHARACTERISTICS (25°C UNLESS NOTED) CHANNEL-1

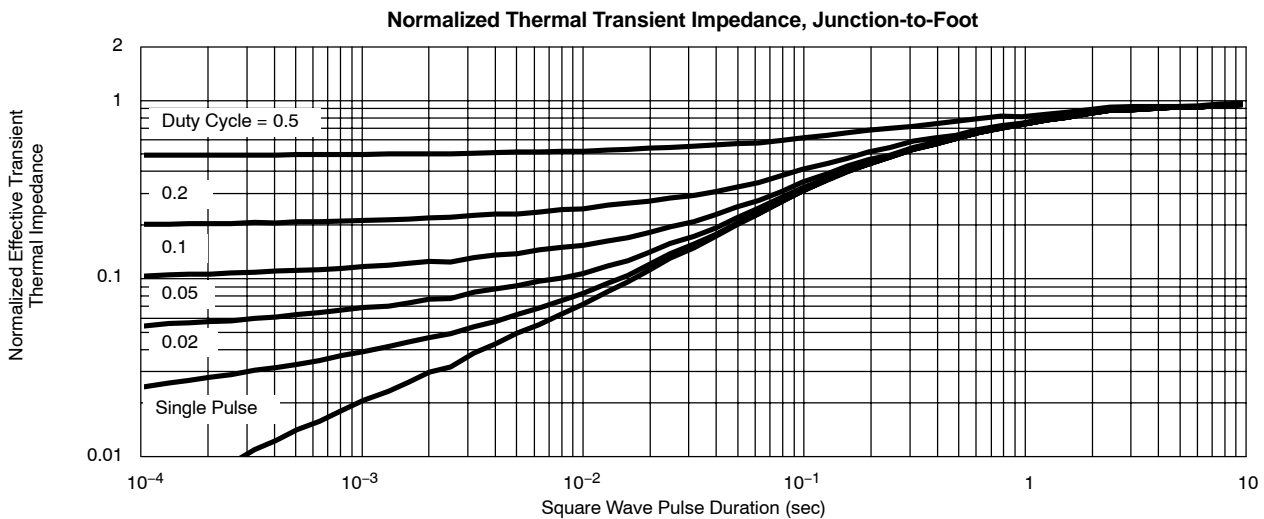
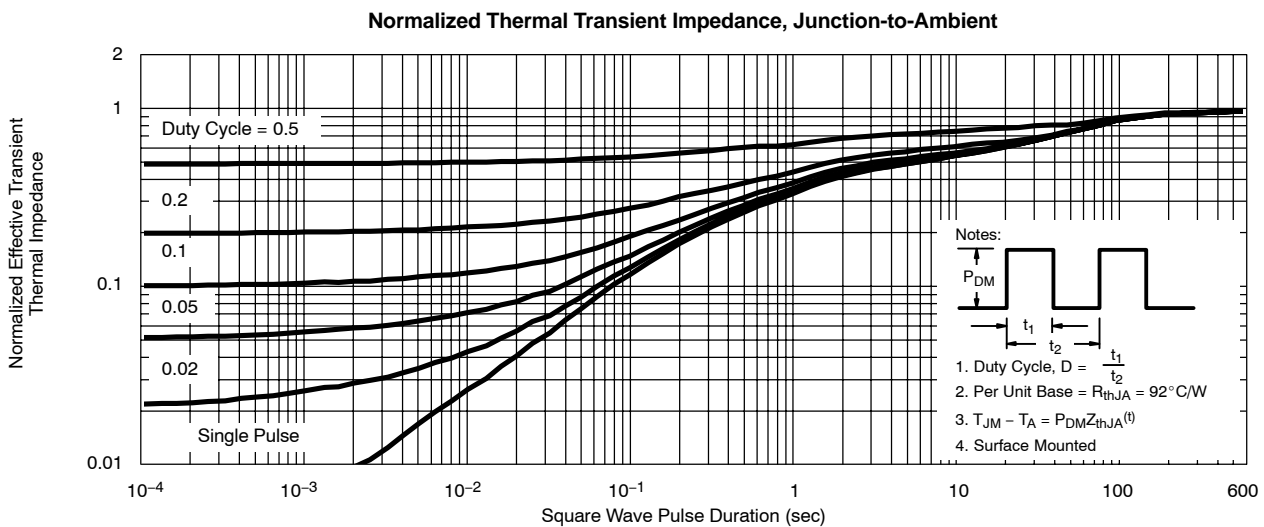
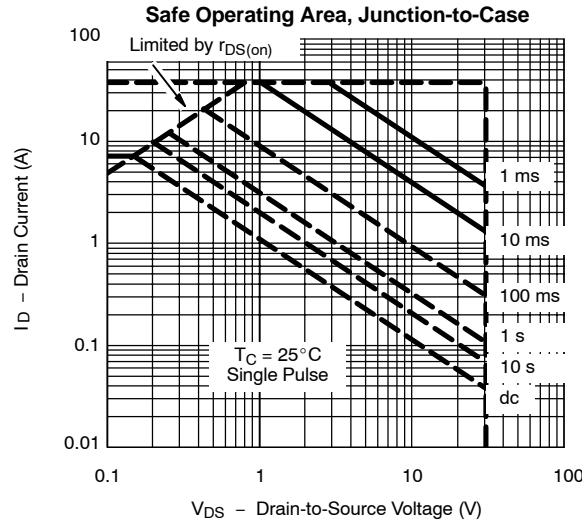

TYPICAL CHARACTERISTICS (25°C UNLESS NOTED)

CHANNEL-2

Output Characteristics

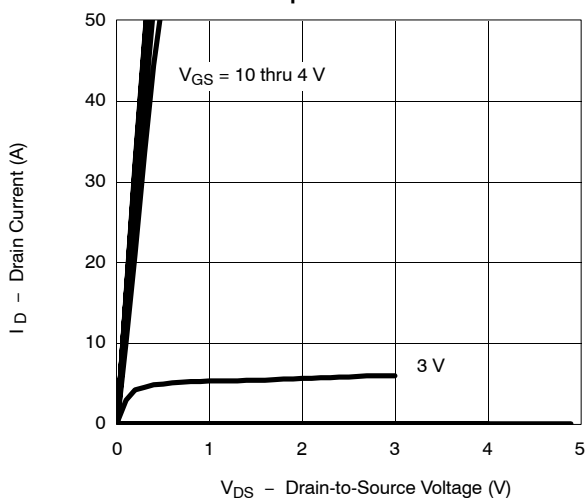

Transfer Characteristics

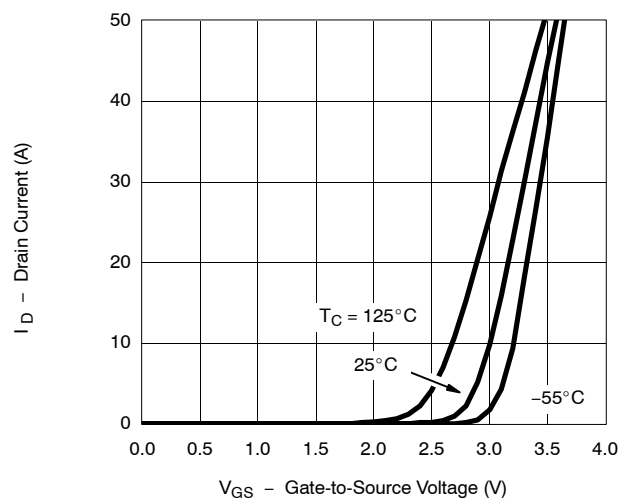

On-Resistance vs. Drain Current

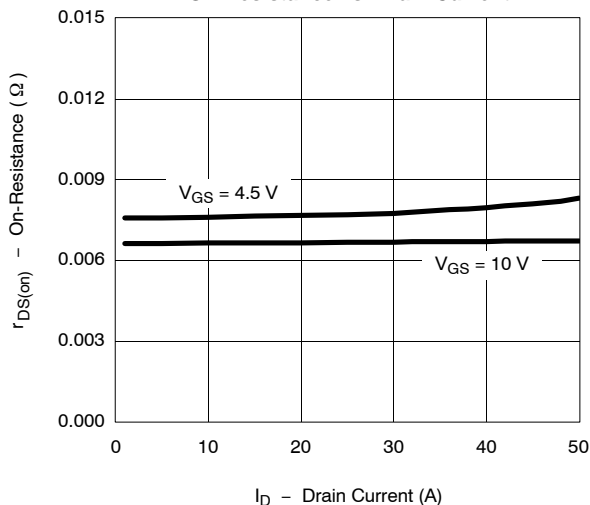

Capacitance

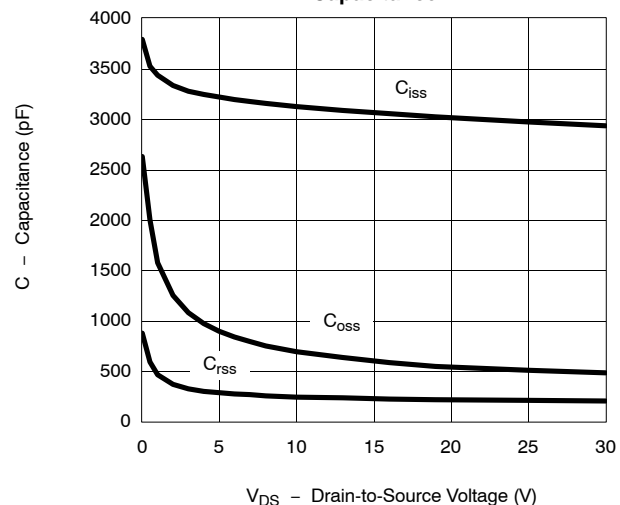

Gate Charge

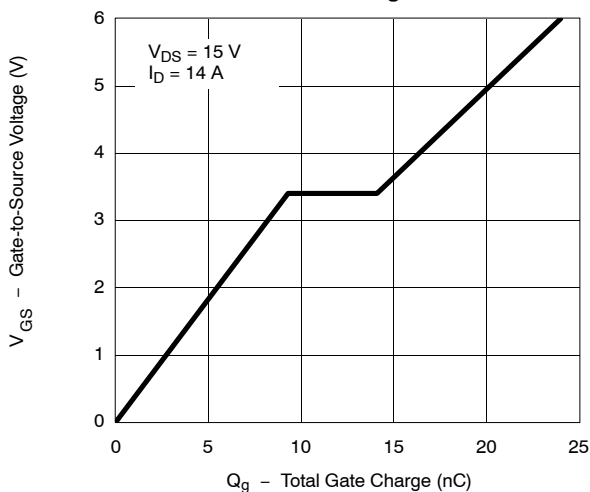

On-Resistance vs. Junction Temperature

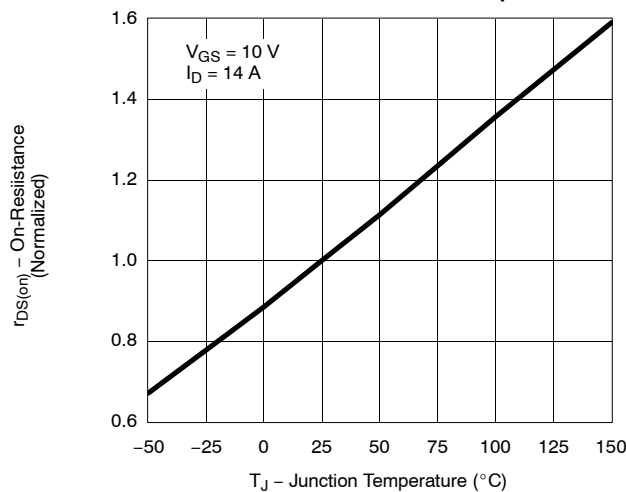



TYPICAL CHARACTERISTICS (25°C UNLESS NOTED)

CHANNEL-2

Source-Drain Diode Forward Voltage

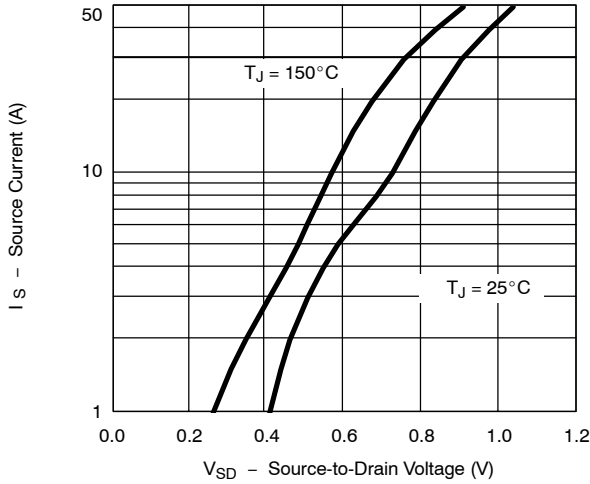

On-Resistance vs. Gate-to-Source Voltage

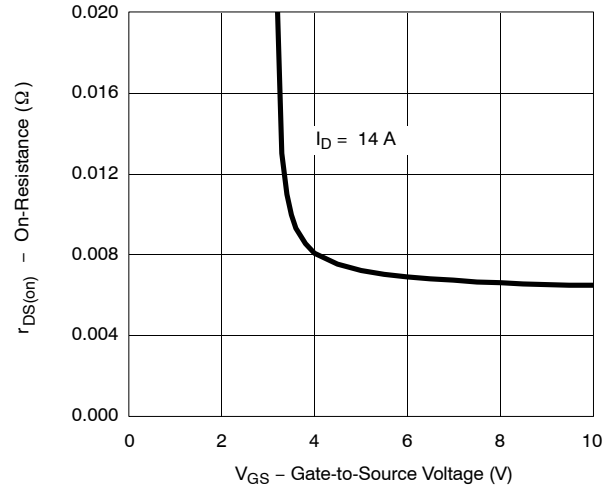

Reverse Current vs. Junction Temperature

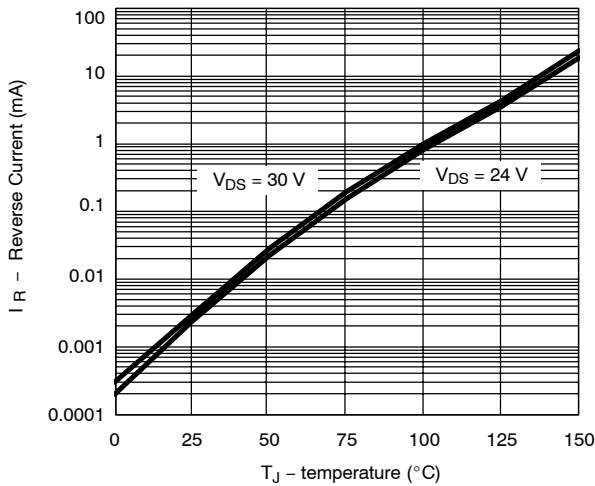

Single Pulse Power

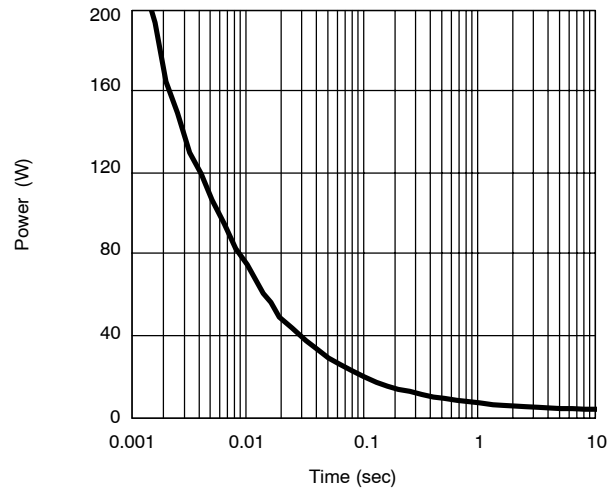

Safe Operating Area, Junction-to-Case

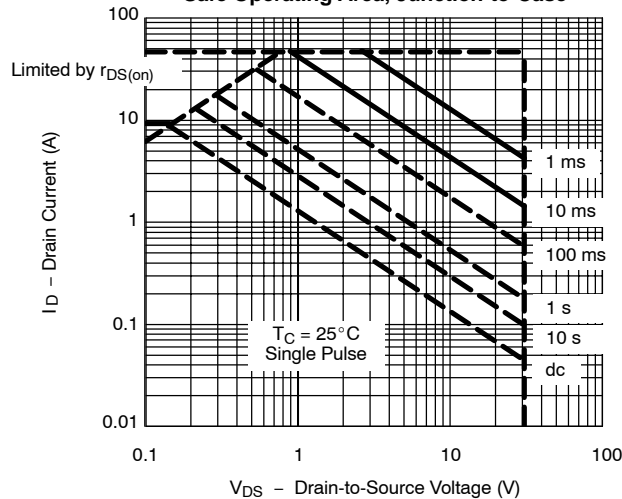

TYPICAL CHARACTERISTICS (25 °C UNLESS NOTED)

CHANNEL-2

Normalized Thermal Transient Impedance, Junction-to-Ambient

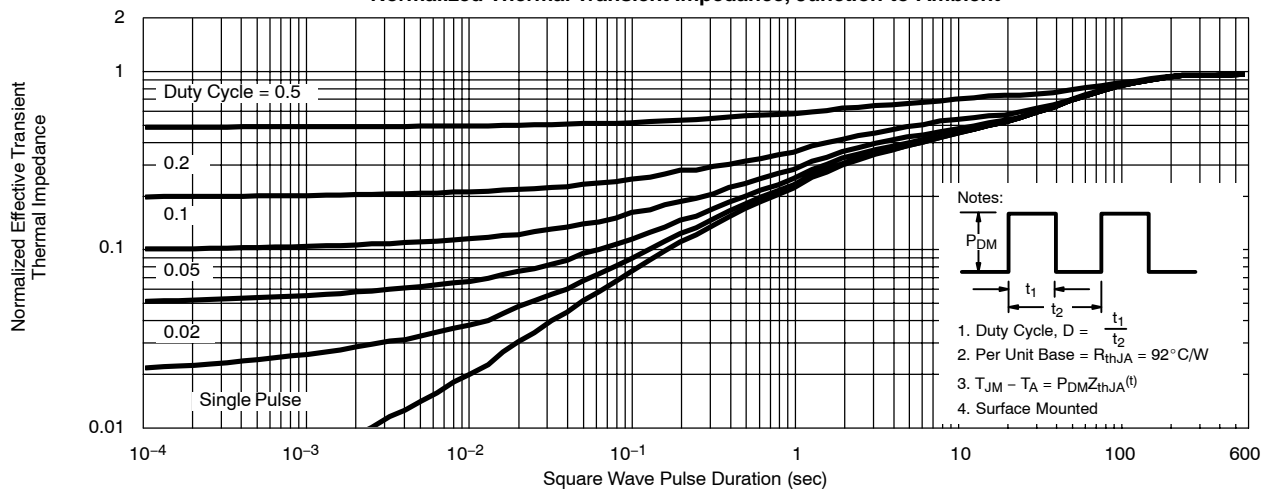

Normalized Thermal Transient Impedance, Junction-to-Foot

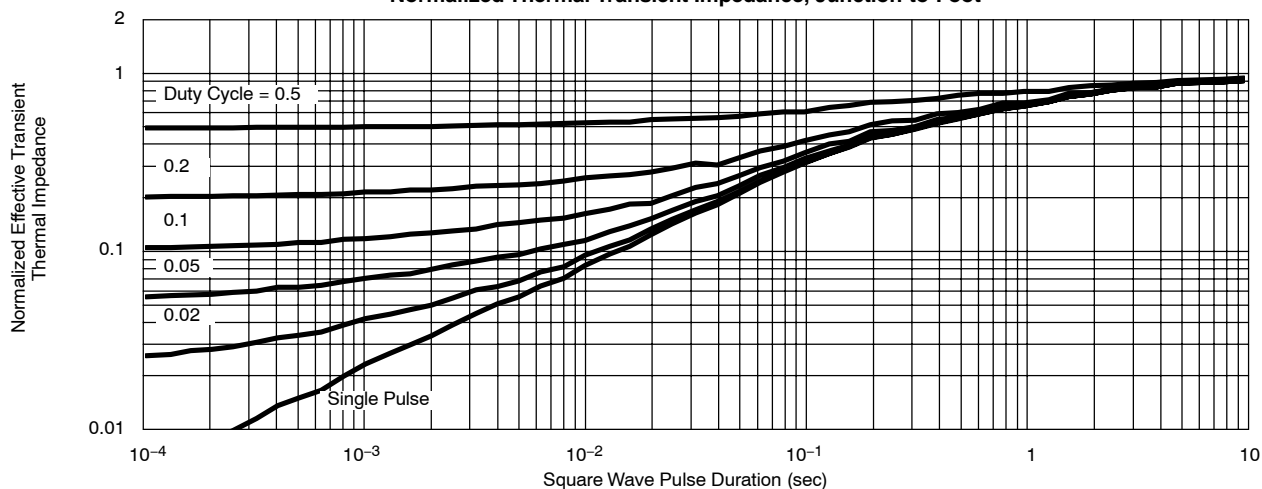

TYPICAL CHARACTERISTICS (25 °C UNLESS NOTED)

SCHOTTKY

Reverse Current vs. Junction Temperature

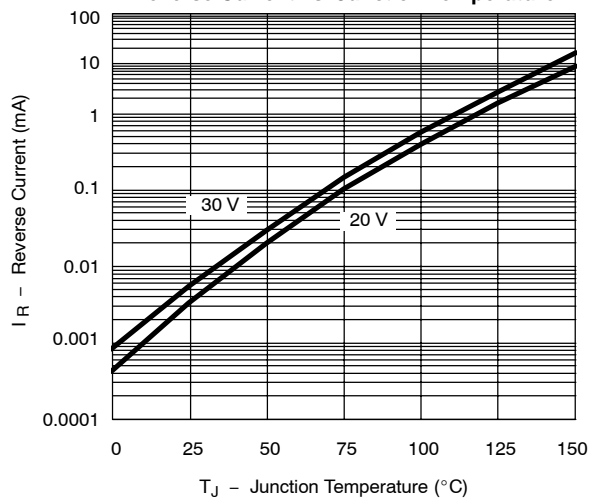

Forward Voltage Drop

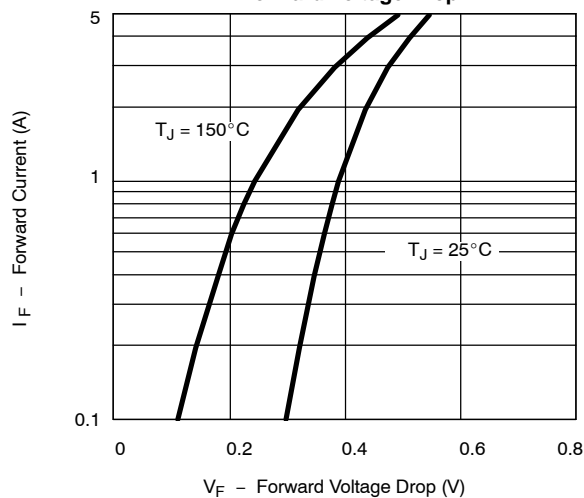



TYPICAL CHARACTERISTICS (25°C UNLESS NOTED) **SCHOTTKY**

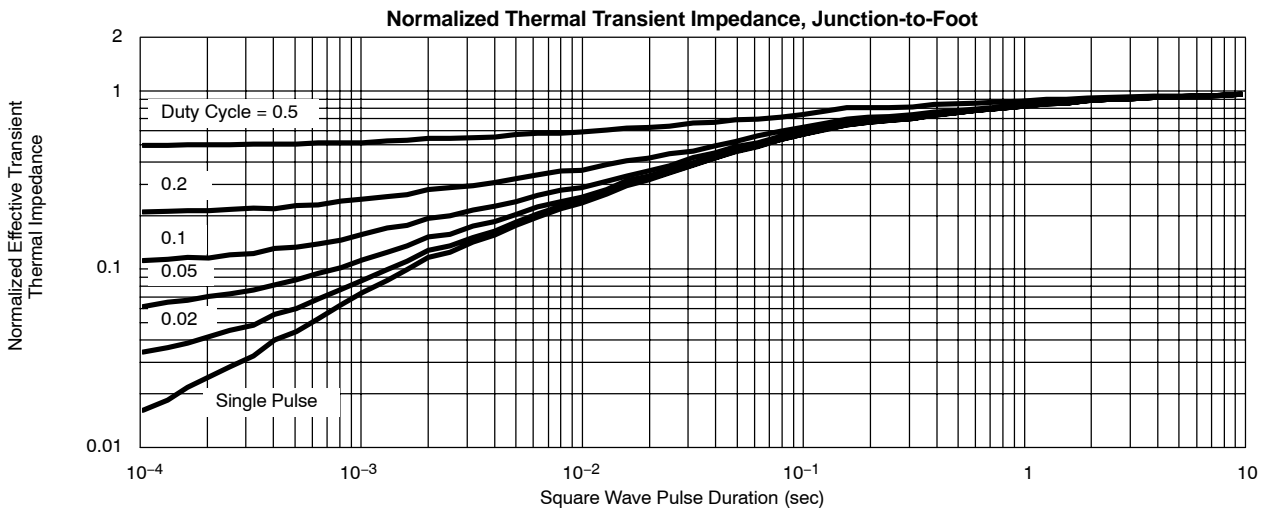
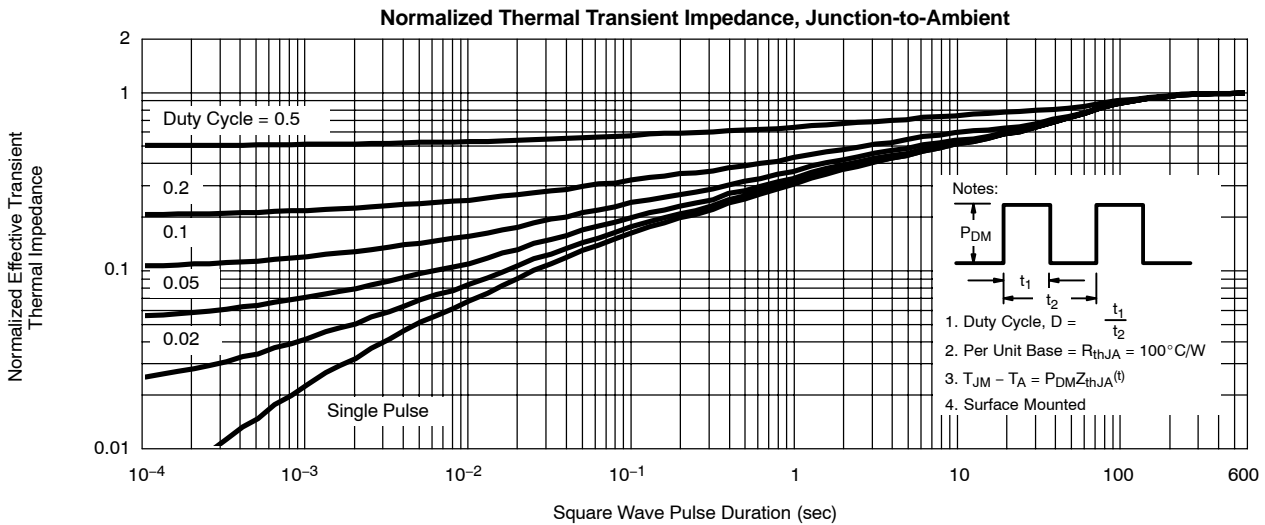
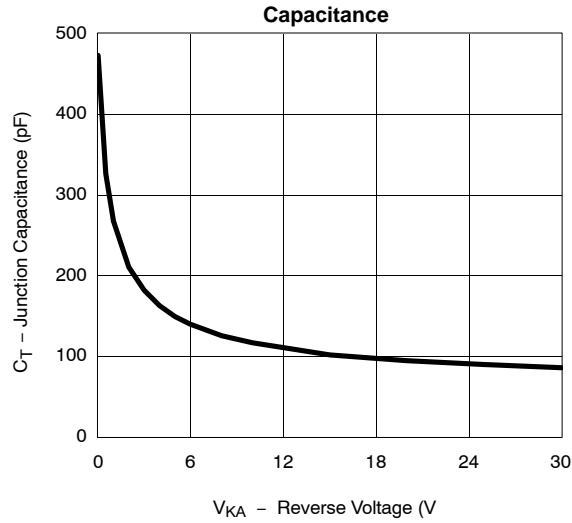



Notice

Specifications of the products displayed herein are subject to change without notice. Vishay Intertechnology, Inc., or anyone on its behalf, assumes no responsibility or liability for any errors or inaccuracies.

Information contained herein is intended to provide a product description only. No license, express or implied, by estoppel or otherwise, to any intellectual property rights is granted by this document. Except as provided in Vishay's terms and conditions of sale for such products, Vishay assumes no liability whatsoever, and disclaims any express or implied warranty, relating to sale and/or use of Vishay products including liability or warranties relating to fitness for a particular purpose, merchantability, or infringement of any patent, copyright, or other intellectual property right.

The products shown herein are not designed for use in medical, life-saving, or life-sustaining applications. Customers using or selling these products for use in such applications do so at their own risk and agree to fully indemnify Vishay for any damages resulting from such improper use or sale.