

### Description

The Si4720/21 is the first single chip FM radio transceiver. The proven and patented digital architecture of the Si4720/21 combines the functionality of the Si470x FM radio receiver with the Si471x FM transmitter, offering full FM receive and transmit capabilities in a single, ultra-small 3x3x0.55 mm QFN package. The device leverages Silicon Lab's highly successful and proven FM technology, and offers unmatched integration and performance allowing FM receive and transmit to be added to any portable device by using a single chip. As with the Si470x and Si471x products, the Si4720/21 offers industry leading size, performance, low power consumption, and ease of use.

The Si4720/21's digital integration reduces the required external components of traditional offerings, resulting in a solution requiring only an external inductor and bypass capacitor, and a PCB space of approximately 15 mm<sup>2</sup>. The Si4720/21 is layout compatible with Silicon Laboratories' Si470x FM radio receivers, Si473x AM/FM radio receivers, and the Si471x FM radio transmitter solutions, allowing a single PCB layout to accommodate a variety of music features. High yield manufacturability, unmatched performance, easy design-in, and software programmability are key advantages of the Si4720/21.

The Si4721 is the industry's first single-chip integrated FM radio transceiver including both receive and transmit support for the European Radio Data System (RDS) and the U.S. Radio Broadcast Data System (RBDS) standards. RDS allows digital information sent from the broadcaster to be displayed, such as station ID, song name and music category. In Europe, alternate frequency (AF) information is also provided to automatically change stations in areas where broadcasters use multiple frequencies. In transmit mode, digital information such as artist name, song title, music category, and branded messaging can be transmitted and displayed on any RDS/RBDS receiver.

Users are responsible for adjusting their system's radiated power levels to comply with local regulations on RF transmission (FCC, ETSI, ARIB, etc.).

### Features

- Integrated FM antenna support
- Excellent real-world performance
- Only two external components required
- Worldwide FM band support (76 to 108 MHz)
- RDS/RBDS processor (Si4721)
- Frequency synthesizer with integrated VCO
- Adjustable seek parameters
- Adjustable mono/stereo blend
- Adjustable soft mute
- Programmable transmit output voltage control
- Audio dynamic range control
- Advanced modulation control
- Analog/digital audio interface
- Programmable reference clock input
- Programmable pre/de-emphasis (50/75 μs)
- 2-wire and 3-wire control interface
- Integrated LDO regulator
- 2.7 to 5.5 V supply voltage
- 3x3x0.55 mm 20-pin Pb-free QFN package

### Applications

- Cellular handsets/hands free
- MP3 players
- Portable media players
- GPS/navigation devices
- Satellite digital audio radios
- Personal computers

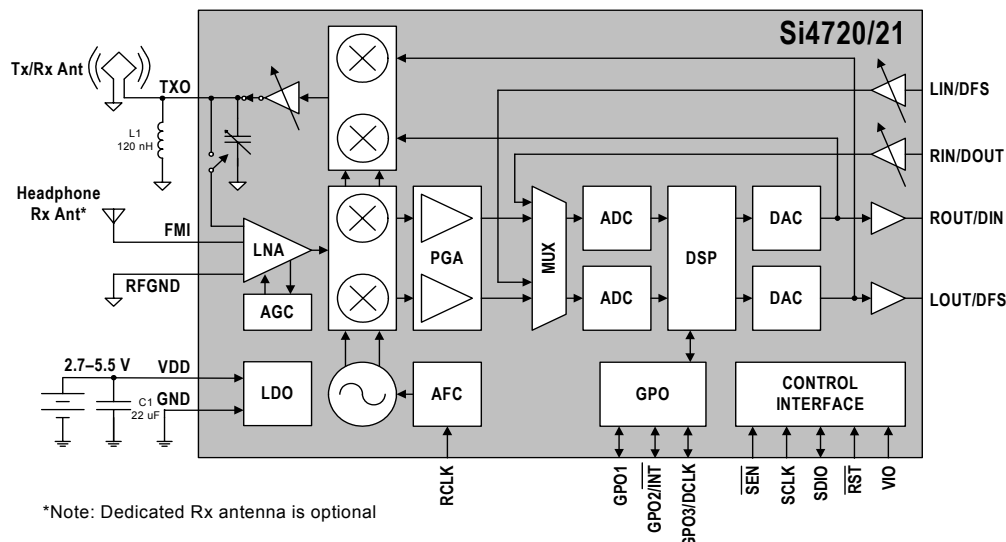

### Selected Electrical Specifications

Parameter	Symbol	Test Condition	Min	Typ	Max	Unit
Frequency Range	$f_{RF}$		76	—	108	MHz
Sensitivity Headphone Matching		(S+N)/N = 26 dB	—	2.2	3.5	$\mu$ V EMF
Sensitivity 50 $\Omega$ Matching		(S+N)/N = 26 dB	—	1.1	—	$\mu$ V EMF
Input IP3		$ f_2 - f_1  > 1$ MHz; $f_0 = 2 \times f_1 - f_2$ AGC disabled	100	105	—	dB $\mu$ V EMF
Adjacent Channel Selectivity		$\pm 200$ kHz	35	50	—	dB
Alternate Channel Selectivity		$\pm 400$ kHz	60	70	—	dB
RX Audio Output Voltage			72	80	90	mVrms
RX Audio Mono S/N			55	63	—	dB
RX Audio THD			—	0.1	0.5	%
Programmable Transmit Output Voltage, TXO			—	118	—	dB $\mu$ V
Transmit Voltage Accuracy		$V_{RF} = 102-118$ dB $\mu$ V	-2.5	—	2.5	dB
Transmit Channel Edge Power			—	—	-20	dBc
Transmit Adjacent Channel Power			—	-30	-26	dBc
Pre/de-emphasis Time Constant		TX_PREMPHASIS = 75 $\mu$ s	70	75	80	us
		TX_PREMPHASIS = 50 $\mu$ s	45	50	54	us
TX Audio SNR			—	63	—	dB
TX Audio THD			—	0.1	—	%
TX Audio Stereo Separation			30	35	—	dB
TX Sub Carrier Rejection Ratio	SCR		40	50	—	dB
TX Audio Input Signal Level (0 dB)	$V_{AI}$	$V_{IO} = 1.8$ V	—	—	0.636	$V_{pk}$
Supply Voltage	$V_{DD}$		2.7	—	5.5	V
Interface Supply Voltage	$V_{IO}$		1.5	—	3.6	V
RX Supply Current	$I_{RX}$		—	19.2	22	mA
TX Supply Current	$I_{TX}$	FM TX from Line Input	—	18.8	22.8	mA

### Pin Assignments

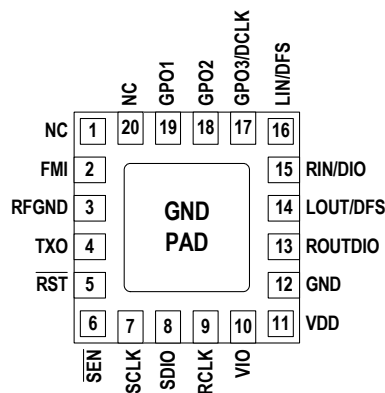

### Package Information

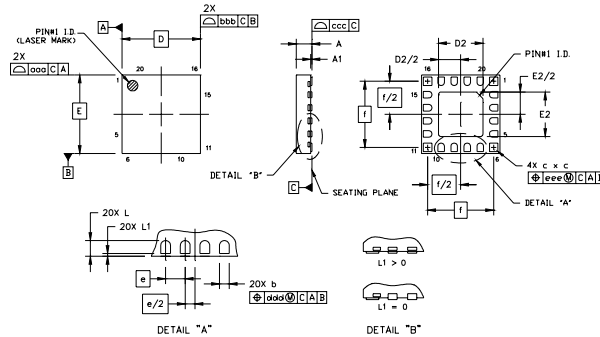

Symbol	Millimeters		
	Min	Nom	Max
A	0.50	0.55	0.60
A1	0.00	0.02	0.05
b	0.18	0.25	0.30
c	0.27	0.32	0.37
D	3.00 BSC		
D2	1.60	1.70	1.80
e	0.50 BSC		
E	3.00 BSC		
E2	1.60	1.70	1.80

Symbol	Millimeters		
	Min	Nom	Max
f	2.53 BSC		
L	0.35	0.40	0.45
L1	0.00	—	0.10
aaa	—	—	0.10
bbb	—	—	0.10
ccc	—	—	0.08
ddd	—	—	0.10
eee	—	—	0.10