

FB Series

Plastic Control Boxes



IDEC CORPORATION

Lightweight Plastic Boxes with IP65 Protection

A wide variety of $\varnothing 22\text{mm}$ control units can be installed.

Cover: Light Beige
 Dimensions: 76/140/200H \times 76W \times 59.5D mm
 Mounting Holes: 0 to 5 for mounting control units



HW Series

TW Series

XW Series
 (Emergency Stop Switch)

For Emergency Stop Switch

Cover: Yellow
 Dimensions: 76H \times 76W \times 59.5D mm
 Mounting Holes: 1 for mounting a control unit

Blank types

Blank enclosures, without mounting holes, are conducive to custom designed layouts, and also allow the user to install control units of other sizes.

Accessories

A wide variety of accessories can be installed to suit individual applications.

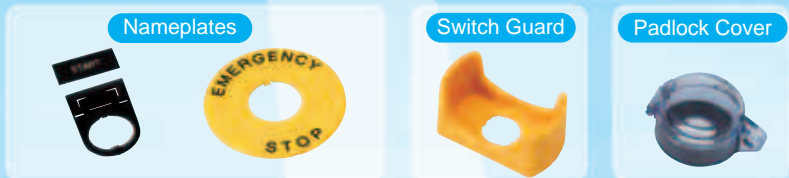

Yellow enclosure with switch guards HW9Z-KG3 and HW9Z-KG4 are SEMI S2 compliant. For details, see the SEMI EMO Switch Guards catalog (EP1125).

(06/07/04)

A Wide Variety of Control Units Can Be Installed.



A Wide Variety of Applications

Contact Cover Box

Control units become IP65 when covered with the contact cover box (Type No. FB1WR-111Z. See pages 6 and 7 for details).

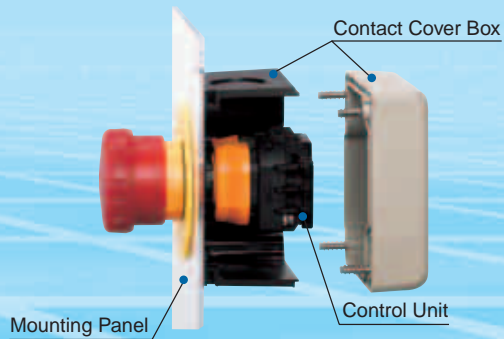

Junction Box

Control boxes without mounting holes can also be used as junction boxes to enclose terminal blocks.



Applicable terminal blocks:
BN10W, BN15MW, BN15LW, BN30W, BA111T, BA211T, BA311T

A wide variety of mounting styles to suit your applications

• Front Panel Mounting

The control boxes can be mounted to the front of the panel.
For details, see page 5.

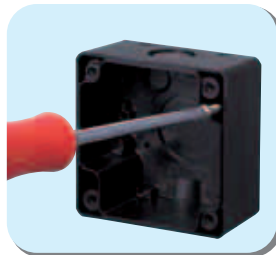

• Hook Mounting

The control boxes can be hung on a hook.



• Rear Panel Mounting

The control boxes can be mounted from behind the panel.
For details, see page 5.

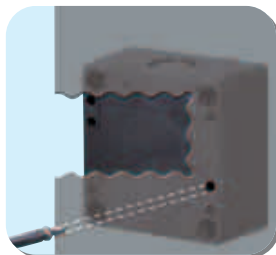

• Frame Mounting

The control boxes can be mounted on the middle, right, or left side of an aluminum frame by using two FB9Z-PK1 mounting brackets on the top and bottom of the box.
For details, see page 7.



FB Series Plastic Control Boxes

IP65 lightweight plastic enclosures for installing control units.

- $\varnothing 22\text{mm}$ control units can be installed.
- Blank front control boxes, without mounting holes, are also available.
- Blank front control boxes can also be used as junction boxes to mount terminal blocks.
- Yellow cover version for emergency stop switches is also available.
- Front panel mounting, rear panel mounting, hook mounting, and frame mounting options are available.
- UL/c-UL listing - pending

Types

• Box

Box Size	No. of Mounting Holes	Mounting Hole Description	Cover Color	Type No.
76mm	0	Without mounting hole	Light beige	FB1T-000Z
	1	$\varnothing 22\text{mm}$	Yellow	FB1W-111Y
	1	$\varnothing 22\text{mm}$		FB1W-111Z
140mm	0	Without mounting hole	Light beige	FB2T-000Z
	2	$\varnothing 22\text{mm}$, mounting centers 50mm		FB2W-211Z
	3	$\varnothing 22\text{mm}$, mounting centers 30mm		FB2W-312Z
200mm	0	Without mounting hole	Light beige	FB3T-000Z
	3	$\varnothing 22\text{mm}$, mounting centers 50mm		FB3W-311Z
	4	$\varnothing 22\text{mm}$, mounting centers 36mm		FB3W-413Z
	5	$\varnothing 22\text{mm}$, mounting centers 30mm		FB3W-512Z

• Specifications (Note 1)

Standard Operating Conditions	Ambient temperature: -25 to $+60^{\circ}\text{C}$ (no freezing) Relative humidity: 45 to 85%RH (no condensation) Storage temperature: -40 to $+80^{\circ}\text{C}$ (no freezing) Degree of pollution: 3
Degree of Protection	IP65 (when IP65 control units are installed) NEMA Type 4X Indoor Use Only (when Type 4X control units are installed)
Electric Shock Protection	Class II (when class II control units are installed)
Material	Cover/base: Polycarbonate Cover mounting screws: Stainless steel
Applicable Control Units	IDEC's HW/TW/XW series control units and accessories (Note 2) (Note 3)
Weight (approx.)	76mm type: 125g (FB1W-111Z) 140mm type: 184g (FB2W-211Z) 200mm type: 243g (FB3W-311Z)

Note 1: The above specifications are for control boxes. For control units, refer to the specifications of each control unit.

Note 2: Choose control units and accessories which match the mounting hole centers, effective depth behind the cover, and the thickness of the cover where control units are installed (3 mm). Note that control boxes with 30mm or 36mm mounting hole centers may limit the knob orientation of selector switches, because the contact blocks can be mounted in one direction only on these mounting centers.

Note 3: An XW series emergency stop switch of screw terminal type can be installed on a control box with one mounting hole or mounting holes of 50mm mounting centers, by connecting one clamping terminal to one terminal pole.

• Contact Cover Box

Size	No. of Mounting Holes	Mounting Hole Description	Cover Color	Type No.
76mm	1	$\varnothing 22\text{mm}$ hole in the base	Light beige	FB1WR-111Z

- Cover does not have a control unit mounting hole.
- For operating instructions, see page 6 and 7.

• Accessories

Description	Type No.	Ordering Type No.	Package Quantity
Mounting Bracket	FB9Z-PK1	FB9Z-PK1	1
DIN Rail Adapter	FB9Z-PK3	FB9Z-PK3PN02	2

- For the dimensions and operating instructions, see pages 7 and 8.
- Connectors and nuts are supplied by users.

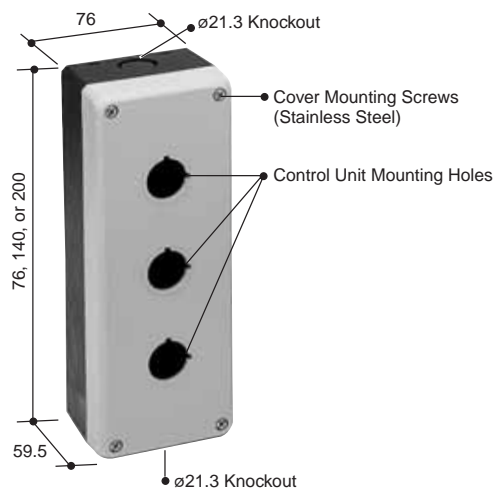

Dimensions

• 76mm Type (FB1)

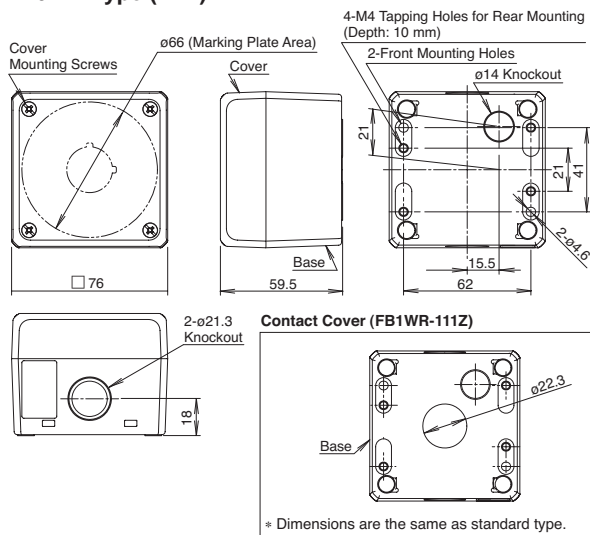

All dimensions in mm.

FB Series Plastic Control Boxes

• 140/200mm Type (FB2/FB3)

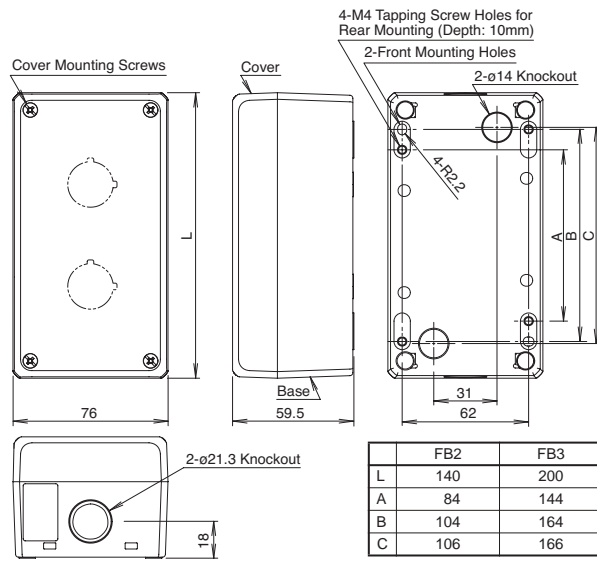

All dimensions in mm.

Control Unit Mounting Hole Centers

Type	FB1	FB2		FB3		
		2 mounting holes	3 mounting holes	3 mounting holes	4 mounting holes	5 mounting holes
Appearance						

Mounting Hole Dimensions

Type	FB1	FB2	FB3	FB2/FB3
		50mm mounting centers	36/50mm mounting centers	30mm mounting centers
Shape				

Note: For contact cover boxes, see page 4.

Internal Dimensions

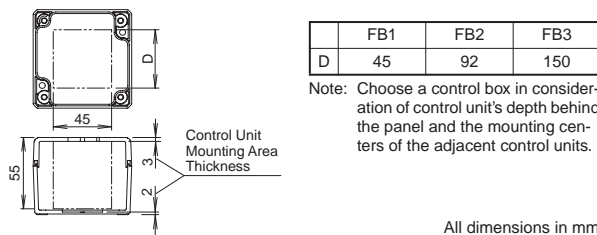

Applicable Accessories

Series	Description
HW Series Control Units	Nameplate: HWAM, HWAQ, HWAS, HWAV-*
	Marking plate for nameplate: HWNP-*
	Anti-rotation ring: HW9Z-RL
	EMO switch guard: HW9Z-KG3, HW9Z-KG4
	Switch guard: HW9Z-K1, HW9Z-K11
	Pushbutton clear boot: OC-31, OC-32
XW Series Emergency Stop Switches	Padlock cover: HW9Z-KL1
	Nameplate: HWAV-*
	EMO switch guard: HW9Z-KG3, HW9Z-KG4
	Anti-rotation ring: HW9Z-RL

TW Series Control Units	Nameplate:	NWA-*, NWAQ-*, NWAAS-0, NVAL-0, NWAQL-0, NWA-*
	Anti-rotation ring:	OGL-31
	Metal protector:	OLW-C
	Pushbutton clear boot:	OC-31, OC-32
	Button cover:	OCW-10*, OCW-11*
	Padlock cover:	HW9Z-KL1, HS9Z-PC22

Note: Confirm the specifications of control box, control units, and accessories before choosing accessories, referring to separate catalogs.

Applicable DIN Rail

Description	Material	Type No.
DIN Rail	Aluminum	BAA1000
	Steel	BAP1000
Mounting Clip	Steel	BNL6

Note: Use DIN rail adapters FB9Z-PK3 when installing a DIN rail in the control box. See pages 7 and 8.

Applicable Terminal Block / Transformer

Series / Type No.	
Terminal Block	BN-W Series: BN10W, BN15MW, BN15LW, BN30W
	BA Series: BA111T, BA211T, BA311T
Separate Mounting Transformer	TWR5**

Note: Install the terminal blocks and separate mounting transformers on a DIN rail using two DIN rail adapters (FB9Z-PK3). Choose the types and quantity of terminal blocks, transformers, mounting clips, and control boxes carefully taking the specifications into consideration. The separate mounting transformer can be installed on a DIN rail adapter directly.

Instructions

Installation

Panel Mounting

1. Installing the FB series from the front

- Using two M4 screws, install the base onto the panel. Recommended tightening torque: 1.4 to 2.0 N·m

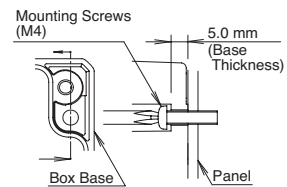

- * Determine the screw length in consideration of the base and panel thickness.
- * Mounting screws are not supplied with the FB series. Use M4 mounting screws.

2. Installing the FB series from the rear

- Insert four M4 tapped screws into holes for tapping screws on the back of the base (depth: 8 to 10 mm, tapping screw hole diameter: $\phi 3.7$ mm), and fasten the screws to a tightening torque of 1.3±0.1 N·m (Nitto Seiko M4-P-TITE).

- * Mounting screws are not supplied with the FB series. Use M4 tapping screws (recommended screws: Nitto Seiko M4-P-TITE).
- * The value of the recommended tightening torque has been confirmed with a M4 tapping screw (Nitto Seiko M4-P-TITE). When using other screws, check that the tapping screw hole is not damaged and the screw can be securely tightened.

3. Installation using mounting bracket FB9Z-PK1

- Refer to installation instructions on page 7.

Installing and Removing the Control Unit

- Refer to installation instructions for each control unit.

Installing the Safety Lever Lock for HW Series Control Units (HW9Z-LS, yellow)

- When installing the HW series control units in the direction shown below, install the safety lever lock with the lever in the unlocked position, lock the lever, and push in the safety lever lock.

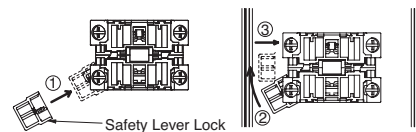

FB Series Plastic Control Boxes

Instructions

Installing the Cable Gland

- Break a desired knockout to mount a cable gland using a hammer and a screwdriver, and install the cable gland.
- When breaking the knockout to make a cable gland hole, be careful not to damage the internal contact block.
- Note that cracks or burrs on the cable gland hole will degrade the waterproof characteristics.



Installing the Cover and Base

- Attach the cover to the base so that the TOP mark on the cover and base are in the same direction.
- Use cover mounting screws to attach the cover to the base. (Recommended tightening torque: 1.3±0.1 N·m)
- Make sure that the cover and the base are attached in the correct direction. Otherwise, the FB series may be damaged.

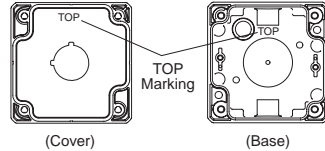

Applicable Crimping Terminal

HW/TW Series

Non-insulated Terminal

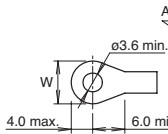

Insulated Terminal

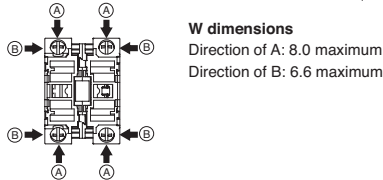
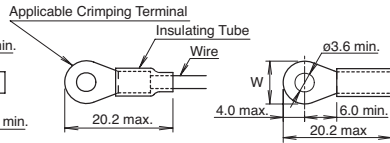

W dimensions
Direction of A: 8.0 maximum
Direction of B: 6.6 maximum

XW Series (Screw Terminal Type)

Non-insulated Terminal

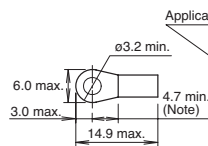

Insulated Terminal

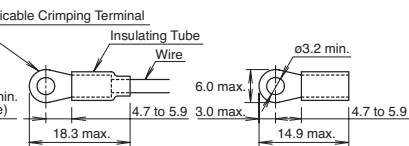

- When a spade terminal is used, the dimension is 4.7 to 5.9 mm.
- Be sure to install an insulating tube on the crimping terminal.
- When using crimping terminals for the XW series, use only one crimping terminal for each terminal.
- Make sure that the wiring does not contact the FB series.

Applicable Cable Gland

- Use cable glands with waterproof characteristics (IP65, TYPE 4X) which can be mounted on a panel thickness of 3 mm or more.
- Locking nuts are not attached.

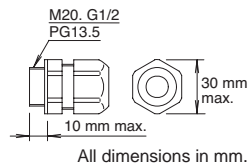

- When using flexible conduit and metal cable gland.

- Applicable Flexible Conduit Example: Type VF-03 (Nihon Flex)

Gland Port Size	Plastic Cable Gland	Metal Cable Gland
M20	—	RLC-103EC20 (Nihon Flex)
G1/2	—	RLC-103 (Nihon Flex)
PG13.5	—	RBC-103PG13.5 (Nihon Flex)

- When using plastic cable gland, metal cable gland and multi-core cable

Gland Port Size	Plastic Cable Gland	Metal Cable Gland
M20	5311 1220 [Skintop-ST-M] Applicable gasket: GPM20 (LAPP, Germany)	ALS-** EC20 (Nihon Flex)
G1/2	5380 6030 [Skintop-ST-PF] Applicable gasket: GP 050 (LAPP, Germany)	ALS16-** (Nihon Flex)
PG13.5	5301 5030 [Skintop-ST] Applicable gasket: GP13.5 (LAPP, Germany)	ABS-** PG13.5 (Nihon Flex)

- Locking nut for installing the cable gland

Gland Port Size	Locking Nut Type No. (made of plastic)
M20	HW9Z-NM20 (IDEC)
G1/2	HW9Z-G (IDEC)
PG13.5	HW9Z-PG135 (IDEC)

- Tighten cable glands to a torque of 3.0±0.3 N·m.
- Insufficient tightening of the cable gland may degrade the waterproof characteristics.
- Electric shock protection Class II is maintained only when a plastic cable gland is used. When using metallic cable glands, install a proper grounding provision or use only one cable gland.
- Determine the cable gland for a multi-core cable according to the outside diameter of the cable sheath.
- When wiring from the back of FB series, use the ø14 knockout on the back of the control box. A cable gland cannot be installed to the ø14 knockout.

Notes

Applicable Wire Size

- Determine the wire size in consideration of the applicable wire for control units and the applicable diameter of cables.

Wiring

- Avoid foreign objects such as dust, liquid, and oil from entering the switch while connecting a conduit or wiring.
- Do not twist or pull the cable of flexible conduit with excessive force. Otherwise, the wire, FB series, and control units may be damaged.
- Because the FB series is not provided with a PG terminal, bonding circuits cannot be interconnected.

Installation of control units on 30mm centers

- When mounting HW/TW series control units on 30mm mounting centers (close mounting), make sure to use a barrier (optional: HW-VG1) to secure the insulation properties of the terminal. The barriers (HW-VG1) can be easily pressed into the side of the contact block.

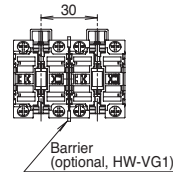

Operation

- Avoid any contact with oil or coolants. Otherwise, the control box may be damaged.
- Use the FB series for INDOOR applications only.

Contact Cover Box

Specifications, applicable units, and wiring

- Same as the standard control boxes.

Installing XW series control units to the FB1WR-112Z contact cover

- Remove the contact block and the locking ring from the operator and check that the rubber gasket is in place. Insert the operator from panel front into the panel hole. Attach the rubber gasket and the base to the operator unit (place the rubber gasket between the panel and the base) and tighten the locking ring using locking ring wrench MW9Z-T1. Recommended tightening torque: 2.0 N·m
- Attach the contact block to the operator. After wiring, attach the cover to the base using four cover mounting screws. Recommended tightening torque: 1.3±0.1 N·m
- Use a nameplate if necessary.

Instructions

- Determine the panel thickness by excluding the thickness of the base (2.0 mm) and accessories (if used) from the maximum panel thickness for the control unit.

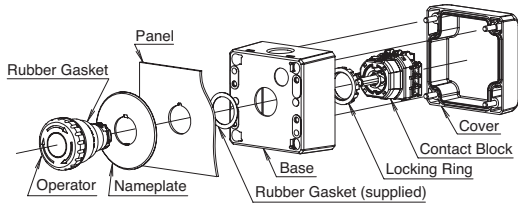

- Do not expose the cable to excessive force, otherwise failure or damage may be caused. When mounting strength is needed, insert M4 tapping screws from the front of the panel (screw tightening depth: 8 to 10mm / tapping screw hole: $\varnothing 3.7\text{mm}$)
- Determine the mounting hole centers referring to the dimensions of the contact cover box on page 4.

Mounting Bracket

Hook Mounting

- Attach the FB9Z-PK1 mounting bracket on the FB series with the supplied screws (two M4 tapping screws). Recommended tightening torque: $1.3 \pm 0.1 \text{ N}\cdot\text{m}$
- Do not tighten the FB9Z-PK1 onto the FB series with excessive force. The tapping screw hole may be damaged and may not securely hold the control box.
- When using the FB9Z-PK1 as hook mounting brackets, make sure that vibrations or shocks do not cause the control box to fall off, and that the control unit operates properly.
- Make sure that the mounting strength is secured.

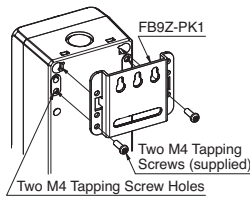

Frame Mounting

- The FB9Z-PK1 can be used as frame mounting brackets by attaching two FB9Z-PK1 as shown at right.
- Attach the FB9Z-PK1 on the FB series with the supplied screws (two M4 tapping screws). Recommended tightening torque: $1.3 \pm 0.1 \text{ N}\cdot\text{m}$.
- Do not tighten the FB9Z-PK1 onto the FB series with excessive force. The tapping screw hole may be damaged and may not securely hold the control box.
- Using two M6 screws, fasten the FB9Z-PK1 securely on the frame. Recommended tightening torque: $5.0 \pm 0.3 \text{ N}\cdot\text{m}$
- * M6 mounting screws and nuts are not supplied with the FB9Z-PK1.
- * The value of the recommended tightening torque for M6 screws has been confirmed with a hexagon socket head screw. When other screws are used and tightened to a smaller torque, make sure that the screws do not become loose after mounting.

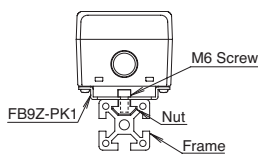

- Do not expose the FB series to excessive force, otherwise failure or damage may be caused.
- Make sure that the mounting strength is secured in consideration of the operation of control unit.

Dimensions

<FB9Z-PK1>

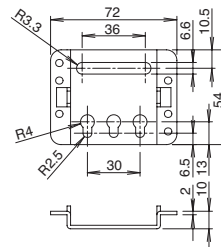

FB Series Control Box			
	FB1	FB2	FB3
L	76	140	200
A	19	18.5	18.5
B	12.5	12	12

<Hook Mounting>

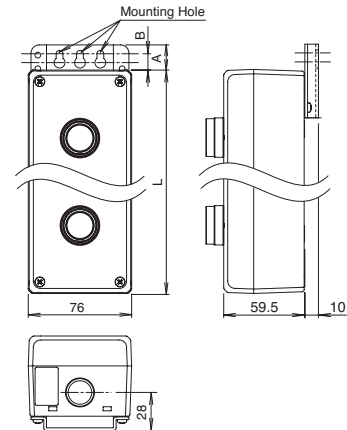

<Frame Mounting>

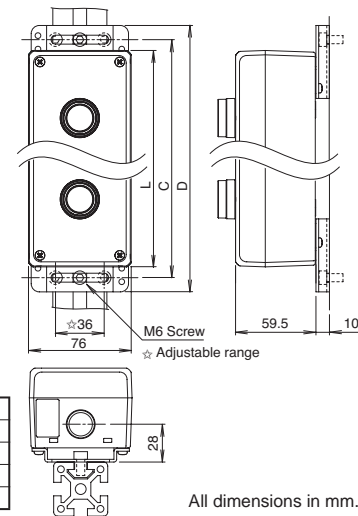

FB Series Control Box			
	FB1	FB2	FB3
L	76	140	200
C	93	156	216
D	114	177	237

All dimensions in mm.

DIN Rail Adapter

Installing the FB9Z-PK3 DIN Rail Adapter

- To attach the FB9Z-PK3 on the FB series, position the positioning hole of the FB9Z-PK3 with the positioning boss in the control box using four M3 tapping screws (supplied) as shown in the figure below. Recommended tightening torque: $0.9 \pm 0.1 \text{ N}\cdot\text{m}$
- Do not tighten the FB9Z-PK3 onto the FB series with excessive force. The tapping screw hole may be damaged and may not securely hold the control box.

Installing the DIN Rail

- To attach a DIN rail, use plain washers and spring washers on two M5 screws and tighten firmly. Recommended tightening torque: $2.0 \pm 0.1 \text{ N}\cdot\text{m}$
- DIN rail mounting screw (M5) Screw length: (spring washer thickness + plain washer thickness + DIN rail thickness) + 3 to 5 mm

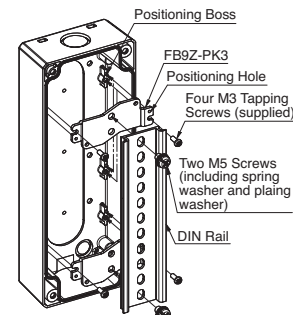

FB Series Plastic Control Boxes

Instructions

- M5 screws, spring washers, and plain washers are not supplied.
- The length of DIN rail must be within the effective internal dimensions.
- Do not tighten the M5 screw onto the FB9Z-PK3 with excessive force. The screw hole may be damaged and may not securely hold the FB9Z-PK3.

Mounting Control Units on DIN Rail

- Refer to each instruction sheet.

Installing the Separate Mounting Type Transformer

- After attaching the FB9Z-PK3 on the FB series, attach the separate mounting type transformer on the FB9Z-PK3, using plain washers and spring washers on two M3 screws as shown in the figure below. Recommended tightening torque: 0.5 to 0.8 N·m

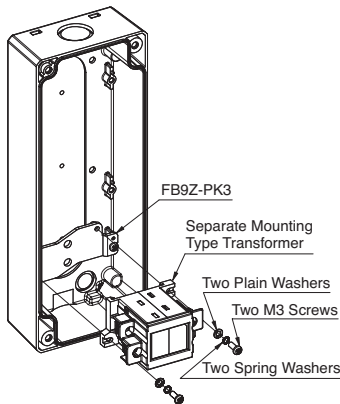

- Separate mounting type transformer mounting screw (M3) Screw Length: (Spring washer thickness) + (Plain washer thickness) + 7 to 10 mm
- M3 screws, spring washers, and plain washers are not supplied.
- Do not tighten the screw with excessive force. The screw hole and the separate mounting type transformer may be damaged.

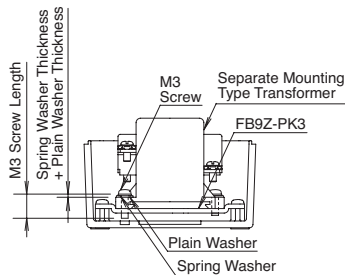

Specifications and other descriptions in this catalog are subject to change without notice.



IDEC CORPORATION

IDEC CORPORATION (USA)
1175 Elko Drive, Sunnyvale, CA 94089-2209, USA
Tel: +1-408-747-0550 / (800) 262-IDEC (4332)
Fax: +1-408-744-9055 / (800) 635-6246
E-mail: opencontact@idec.com

IDEC CANADA LIMITED
Unit 22-151, Brunel Road Mississauga, Ontario, L4Z 1X3, Canada
Tel: +1-905-890-8561, Toll Free: (888) 317-4332
Fax: +1-905-890-8562
E-mail: sales@ca.idec.com

IDEC AUSTRALIA PTY. LTD.
2/3 Macro Court, Rowville, Victoria 3178, Australia
Tel: +61-3-9763-3244, Toll Free: 1800-68-4332
Fax: +61-3-9763-3255
E-mail: sales@au.idec.com

IDEC ELECTRONICS LIMITED
Unit 2, Beechwood, Chineham Business Park, Basingstoke, Hampshire RG24 8WA, UK
Tel: +44-1256-321000, Fax: +44-1256-327755
E-mail: sales@uk.idec.com

IDEC ELEKTROTECHNIK GmbH
Wendenstrasse 331, D-20537 Hamburg, Germany
Tel: +49-40-25 30 54 10, Fax: +49-40-25 30 54 24
E-mail: service@idec.de

IDEC (SHANGHAI) CORPORATION
Room 608-609, 6F, Gangtai Plaza, No. 700, Yan'an East Road, Shanghai 200001, P.R.C.
Tel: +86-21-5353-1000, Fax: +86-21-5353-1263
E-mail: idec@cn.idec.com

IDEC (SHANGHAI) CORPORATION
Beijing Office
Unit 1002, No. 10 Kuntai Building, Zhaowai Dajie, Zhao Yang District, Beijing, 100020, P.R.C.
Tel: +86-10-6599-5541, Fax: +86-10-6599-5540

IDEC (SHENZHEN) CORPORATION
Unit AB-3B2, Tian Xiang Building, Tian'an Cyber Park, Fu Tian District, Shenzhen, Guang Dong 518040, P.R.C.
Tel: +86-755-8356-2977, Fax: +86-755-8356-2944

IDEC IZUMI (H.K.) CO., LTD.
Unit 1505-07, DCH Commercial Centre No. 25, Westlands Road, Quarry Bay, Hong Kong
Tel: +852-2803-8989, Fax: +852-2565-0171
E-mail: info@hk.idec.com

IDEC TAIWAN CORPORATION
8F-1, No. 79, Hsin Tai Wu Road, Sec. 1, Hsi-Chih, Taipei County, Taiwan
Tel: +886-2-2698-3929, Fax: +886-2-2698-3931
E-mail: service@idecwn.com.tw

IDEC IZUMI ASIA PTE. LTD.
No. 31, Tannery Lane #05-01, Dragon Land Building, Singapore 347788
Tel: +65-6746-1155, Fax: +65-6844-5995
E-mail: info@sg.idec.com

www.idec.com

Dimensions

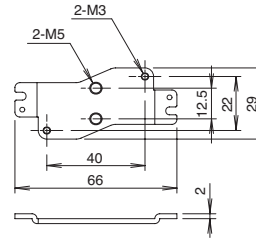
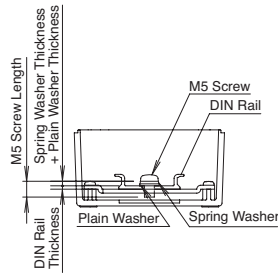

Inside Dimensions of FB Series Control Box

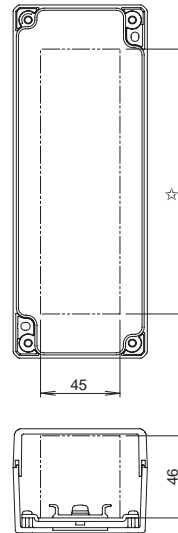

FB9Z-PK3 Installation Positions

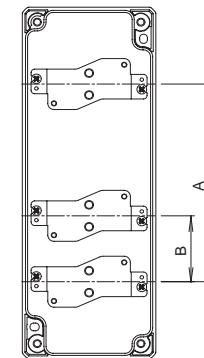

FB Series Control Box		
	FB2	FB3
A	50	112.5
B	—	37.5

☆ See internal dimensions on page 5.

All dimensions in mm.

Other Precautions

- Rated current of terminal blocks depends on operating conditions such as wire type, number of bundle wires, and ambient temperature. Check the specifications of terminal blocks carefully, and use terminal blocks within the specification values. Otherwise electric shock or fire hazard may be caused.
- FB series is rated as Class II protection against electric shock (no reliance on installation protective measures, according to IEC 61140). When using a blank front control box as a junction box and grounding is necessary, provide appropriate grounding, for example installing a grounding terminal block inside the box.
- For wiring, refer to the instructions of the FB series control boxes and control units used.