

PLL frequency synthesizer for tuners

BU2624AF

The BU2624AF is a PLL frequency synthesizer IC designed for use in car stereos, high-fidelity audio systems, and CD radio cassettes.

Featuring low current dissipation, low superfluous radiation, two frequency measurement counter systems, and two phase comparison outputs, this chip is ideal for high-performance multi-band systems.

●Applications

Car stereos, high-fidelity audio systems, radio cassettes, receivers, and other frequency generating devices

●Features

- | | |
|--|--|
| 1) Built-in high-speed prescaler can divide 130MHzVCO. | 5) Unlock detection circuit |
| 2) Low current dissipation (during operation: 6.0mA, PLL OFF: 300µA Typ.) | 6) Five output ports (open drain) |
| 3) Seven standard frequencies: 50kHz, 25kHz, 12.5kHz, 10kHz, 9kHz, 5kHz, and 1kHz. | 7) SD input port |
| 4) Two counters for intermediate frequency detection | 8) Two charge pump outputs |
| | 9) Serial data input (CE, CK, DA) |
| | 10) Control of phase comparison output |

●Absolute maximum ratings (Ta = 25°C)

Parameter	Symbol	Limits	Unit	Conditions
Power supply voltage	V _{DD}	-0.3~+7.0	V	V _{DD}
Maximum input voltage 1	V _{IN1}	-0.3~+7.0	V	CE,CK,DA,SD
Maximum input voltage 2	V _{IN2}	-0.3~V _{DD} +0.3	V	XIN,FMIN,AMIN,IF1,IF2,SD
Maximum output voltage 1	V _{OUT1}	-0.3~+10.0	V	P0, P1, P2, P3, P4, CD
Maximum output voltage 2	V _{OUT2}	-0.3~V _{DD} +0.3	V	PD1, PD2, XOUT
Maximum output current	I _{OUT}	0~4.0	mA	P0, P1, P2, P3, P4, CD
Power dissipation	P _d	450*	mW	
Operating temperature	T _{opr}	-40~+85	°C	
Storage temperature	T _{stg}	-55~+125	°C	

* Reduced by 0mW for each increase in Ta of 1°C over 25°C.

●Recommended operating conditions (Ta = 25°C)

Parameter	Symbol	Min.	Typ.	Max.	Unit
Power supply voltage	V _{DD}	4.0	—	6.0	V

● Block diagram

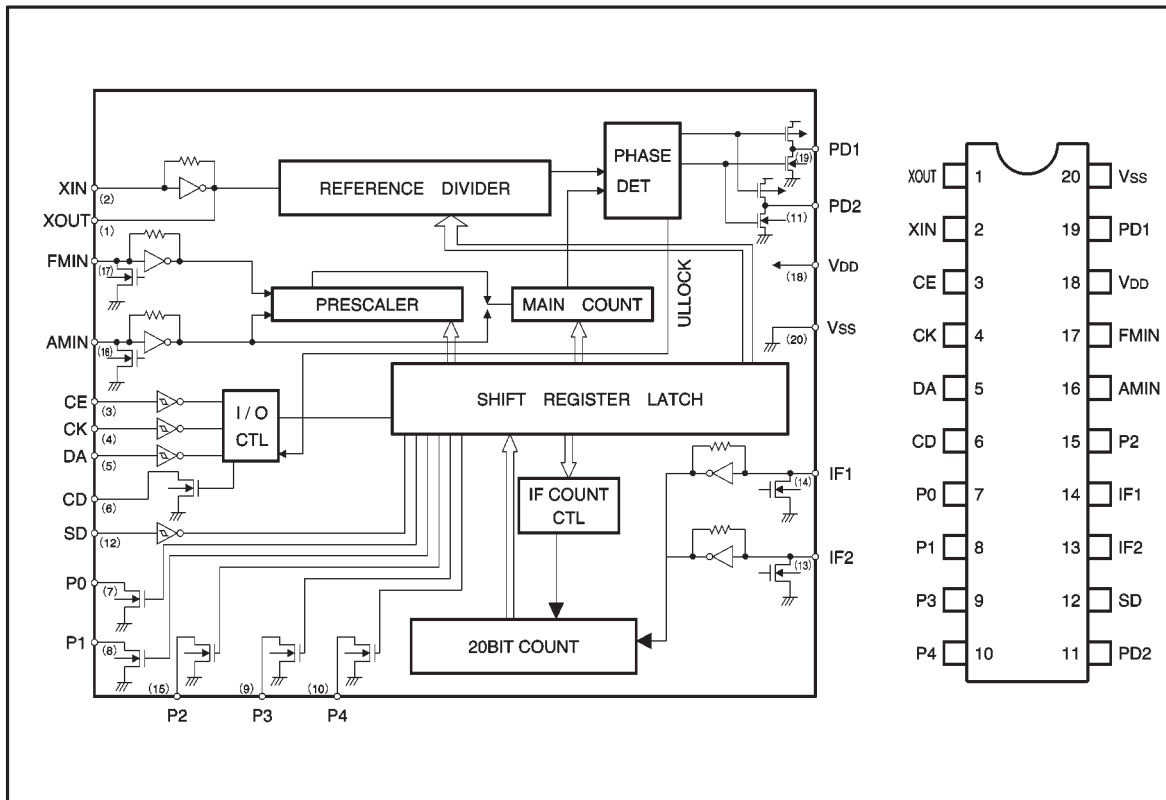

● Pin descriptions

Pin No.	Symbol	Pin name	Function	I / O
1	XOUT	Crystal oscillation	For generation of standard frequency and internal clock. Connected to 7.2 MHz crystal resonator.	OUT
2	XIN			IN
3	CE	Chip enable Clock signal Serial data	When CE is H, DA (which is generated when CK starts) goes to the internal shift register, and is latched according to the timing of CE shutdown. Also, output data is generated from the CD terminal when CK starts up.	IN
4	CK			
5	DA			
6	CD	Count data	Frequency data and unlock data are output.	Nch open drain
7	P0	Output port	Controlled on the basis of input data.	
8	P1			
9	P3			
10	P4			
11	PD2	Phase comparison output	Operates in the same ways as PD1	3-state
12	SD	Input port	Output to the CD.	Schmidt input
13	IF2	IF2 input	Intermediate frequency input Selected on the basis of input data.	IN
14	IF1	IF1 input		
15	P2	Output port	Controlled on the basis of input data.	Nch open drain
16	AMIN	AM input	Local input for AM	IN
17	FMIN	FM input	Local input for FM	IN
18	V _{DD}	Power supply	Power supply, with 4.0V to 6.0V applied voltage.	
19	PD1	Phase comparison output	High level when value obtained by dividing local output is higher than standard frequency. Low level when value is lower. High impedance when value is same.	3-state
20	V _{SS}	GROUND		

●Electrical characteristics (unless otherwise noted, Ta = 25°C, V_{DD} = 5.0V)

Parameter	Symbol	Min.	Typ.	Max.	Unit	Conditions
Power supply current 1	I _{DD1}	—	6.0	10.0	mA	F _{MIN} =130MHz, 100mV _{rms}
Quiescent current	I _{DD2}	—	0.3	1.0	mA	No input, PLL=OFF
Input high level voltage	V _{IH}	0.8V _{DD}	—	—	V	CE, CK, DA, SD
Input low level voltage	V _{IL}	—	—	0.2V _{DD}	V	CE, CK, DA, SD
Input high level current 1	I _{IH1}	—	—	1.0	μA	CE, CK, DA, SD V _{IN} =V _{DD}
Input high level current 2	I _{IH2}	—	0.3	—	μA	XIN V _{IN} =V _{DD}
Input high level current 3	I _{IH3}	—	6.0	—	μA	F _{MIN} , A _{MIN} , IF1, IF2 V _{IN} =V _{DD}
Input low level current 1	I _{IL1}	-1.0	—	—	μA	CE, CK, DA, SD V _{IN} =V _{SS}
Input low level current 2	I _{IL2}	—	-0.3	—	μA	XIN V _{IN} =V _{SS}
Input low level current 3	I _{IL3}	—	-0.6	—	μA	F _{MIN} , A _{MIN} , IF1, IF2 V _{IN} =V _{SS}
Output low level voltage 1	V _{OL1}	—	0.2	0.5	V	P0, P1, P2, P3, P4, CD I _o =1.0mA
Off level leakage current 1	I _{OFF1}	—	—	1.0	μA	P0, P1, P2, P3, P4, CD V _o =10V
Output low level voltage 2	V _{OL2}	—	—	0.3	V	F _{MIN} , A _{MIN} , IF1, IF2 I _{OUT} =0.1mA
Output high level voltage	V _{OH}	V _{DD} 1.0	V _{DD} 0.25	—	V	PD1, PD2 I _{OUT} =-1.0mA
Output low level voltage 3	V _{OL3}	—	0.15	1.0	V	PD1, PD2 I _{OUT} =1.0mA
Off level leakage current 2	I _{OFF2}	—	—	100	nA	PD1, PD2 V _{OUT} =V _{DD}
Off level leakage current 3	I _{OFF3}	-100	—	—	nA	PD1, PD2 V _{OUT} =V _{SS}
Internal feedback resistor 1	R _{F1}	—	10	—	MΩ	XIN
Internal feedback resistor 2	R _{F2}	—	500	—	kΩ	F _{MIN} , A _{MIN} , IF1, IF2
Input frequency 1	F _{IN1}	—	7.2	—	MHz	XIN, Sine wave, C coupling
Input frequency 2	F _{IN2}	10	—	130	MHz	F _{MIN} , Sine wave, C coupling V _{IN} =50mV _{rms}
Input frequency2-1	F _{IN2-1}	20	—	180	MHz	F _{MIN} , Sine wave, C coupling V _{IN} =100mV _{rms}
Input frequency 3	F _{IN3}	0.5	—	30	MHz	A _{MIN} , Sine wave, C coupling V _{IN} =70mV _{rms}
Input frequency 4	F _{IN4}	0.4	—	16	MHz	IF1, IF2, Sine wave, C coupling V _{IN} =70mV _{rms}
Input amplitude 1	F _{IN1}	50	—	1.5	V _{rms}	F _{MIN} , Sine wave, C coupling 10~130MHz
Input amplitude 1-2	F _{IN1-2}	100	—	1.5	V _{rms}	F _{MIN} , Sine wave, C coupling 130~180MHz
Input amplitude 2	F _{IN2}	70	—	1.5	V _{rms}	A _{MIN} , IF1, IF2, Sine wave, C coupling
Minimum pulse width	TW	1.0	—	—	μs	CK, DA
Input rise time	TR	—	—	500	ns	CE, CK, DA
Input fall time	TF	—	—	500	ns	CE, CK, DA

©Not designed for radiation resistance.

● Circuit operation
Input data format

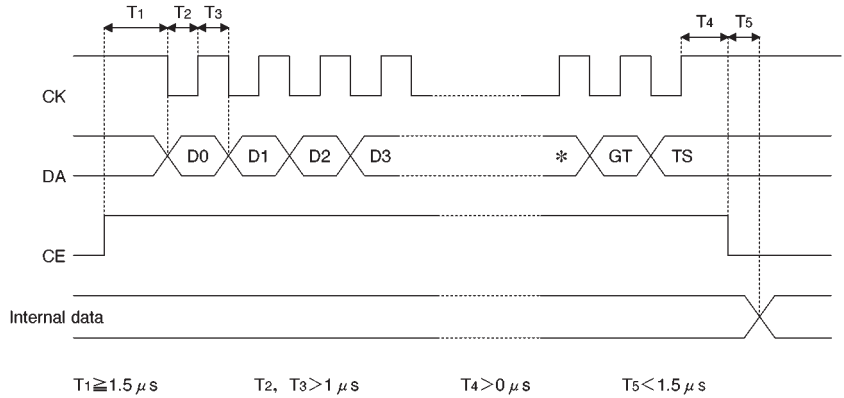

D ₀	D ₁	D ₂	D ₃	D ₄	D ₅	D ₆	D ₇	D ₈	D ₉	D ₁₀	D ₁₁	D ₁₂	D ₁₃	D ₁₄	D ₁₅
----------------	----------------	----------------	----------------	----------------	----------------	----------------	----------------	----------------	----------------	-----------------	-----------------	-----------------	-----------------	-----------------	-----------------

← Input from D0.

P ₀	P ₁	P ₂	P ₃	P ₄	PH	PL	CT	R ₀	R ₁	R ₂	S	PS	IFS	GT	TS
----------------	----------------	----------------	----------------	----------------	----	----	----	----------------	----------------	----------------	---	----	-----	----	----

Output data format CE output is set to LO.

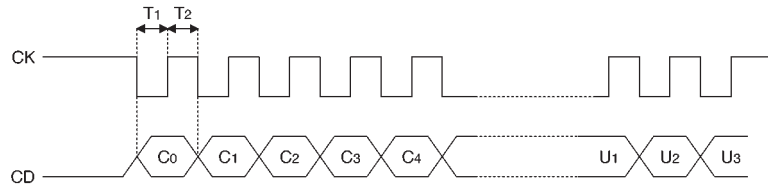

Figures for output assume the presence of pullup resistance. $T_1, T_2 > \mu s$

Output data format

C ₀	C ₁	C ₂	C ₃	C ₄	C ₅	C ₆	C ₇	C ₈	C ₉	C ₁₀	C ₁₁	C ₁₂	C ₁₃	C ₁₄	C ₁₅
----------------	----------------	----------------	----------------	----------------	----------------	----------------	----------------	----------------	----------------	-----------------	-----------------	-----------------	-----------------	-----------------	-----------------

← Input done from C₀.

C ₁₆	C ₁₇	C ₁₈	C ₁₉	U ₀	U ₁	U ₂	U ₃
-----------------	-----------------	-----------------	-----------------	----------------	----------------	----------------	----------------

* Data is output only when CT = 1 or GT = 1.

Explanation of the data

- (1) Division data: For D₀ through D₁₅ (When S = 1, use D₄ through D₁₅.)

D ₀	D ₁	D ₂	D ₃	D ₄	D ₅	D ₆	D ₇	D ₈	D ₉	D ₁₀	D ₁₁	D ₁₂	D ₁₃	D ₁₄	D ₁₅
----------------	----------------	----------------	----------------	----------------	----------------	----------------	----------------	----------------	----------------	-----------------	-----------------	-----------------	-----------------	-----------------	-----------------

Examples:

Divide ratio=1106(D) 1106(D)÷2=553(D)=229(H) S=0

1 0 0 1 | 0 1 0 0 | 0 1 0 0 | 0 0 0 0

Divide ratio=1107(D)=453(H) S=1, PS=1

1 1 0 0 | 1 0 1 0 | 0 0 1 0 | 0 0 0 0

Divide ratio=926(D)=39E(H) S=1, PS=0

× × × × | 0 1 1 1 | 1 0 0 1 | 1 1 0 0

- (2) CT: Frequency measurement beginning data 1: Begins measurement.

0: Resets internal counter, IF1 and IF2 go to pul down.

- (3) Output port control data: P0, P1, P2, P3, P4

- (4) PL PH: Control of charge pump output

PH = 0, PL = 0 PLL operation

PH = 0, PL = 1 PD1 PD2 LO level

PH = 1, PL = 0 PD1 PD2 HI level

PH = 1, PL = 1 PD1 PD2 LO level

- (5) R₀, R₁, R₂, standard frequency data

Data			Standard frequency
R ₀	R ₁	R ₂	
0	0	0	25kHz
0	0	1	12.5kHz
0	1	0	50kHz
0	1	1	10kHz
1	0	0	5kHz
1	0	1	9kHz
1	1	0	1kHz
1	1	1	* PLL OFF

* FMIN = pulldown, AMIN = pulldown, PD = high impedance

- (6) S: switch between FMIN and AMIN 0: FMIN

1: AMIN

- (7) PS: If this bit is set to ON while AMIN is selected, swallow counter division is possible.

- (8) IFS: Selection between IF1 and IF2 during IF count 0: IF1 1: IF2

- (9) GT: Frequency measurement time and unlock detection ON/OFF

CT	GT	Frequency measurement	Unlock detection	Data output
0	0	OFF	OFF	NG
0	1	OFF	ON	OK
1	0	ON Gate time = 8 ms	ON	
1	1	ON Gate time = 16 ms	ON	

- (10) TS: Test data (0) is input

Frequency counter

(1) Structure

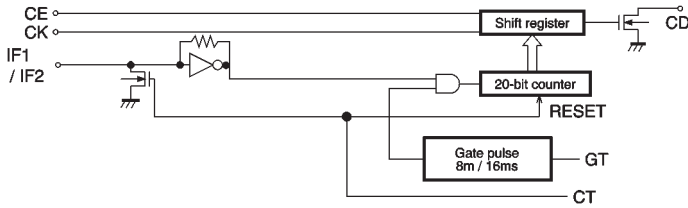

(2) How the frequency counter operates

When control data CT equals 1, the 20-bit counter and the amp go into operation. When CT equals 0, amp input goes to pulldown and the counter is reset.

Measuring time (gate pulse) is selected (8 ms/16 ms) on the basis of control data GT.

When control data CT equals 0, the counter is reset.

(3) Explanation of output data

D0: LSB D19: MSB

Unlock detection

When control data GT equals 1, or CT equals 1, the unlock detection circuit goes into operation for 8ms.

When CT equals 1, the unlock detection circuits stops operating before the frequency counter gate pulse is emitted.

When CT equals 0, or GT equals 0, the unlock detection circuit is reset.

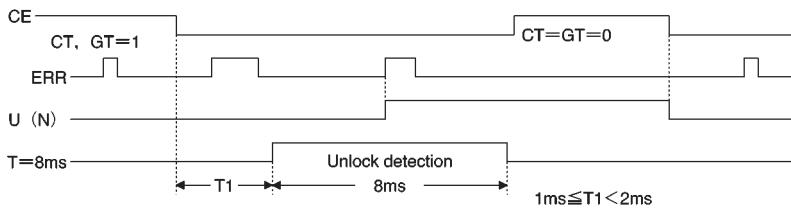

Explanation of the output data

U0	U1	U2	U3	ERR	Time
0	0	0	0	<	1.1 μs
1	0	0	0	<	2.2 μs
1	1	0	0	<	3.3 μs
1	1	1	0	<	4.4 μs
1	1	1	1	<	ERR

Frequency counter and unlock detection

(1) When CT = 1: Frequency count and unlock detection are carried out.

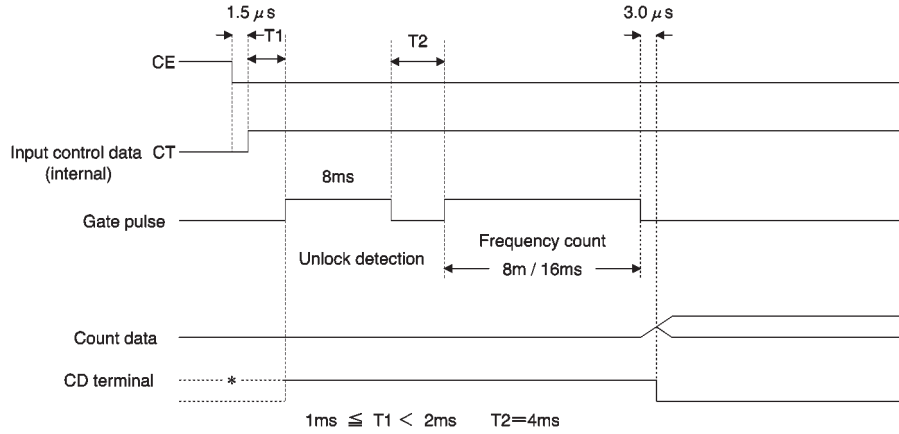

(2) When CT = 0 and GT = 1: Only unlock detection is carried out.

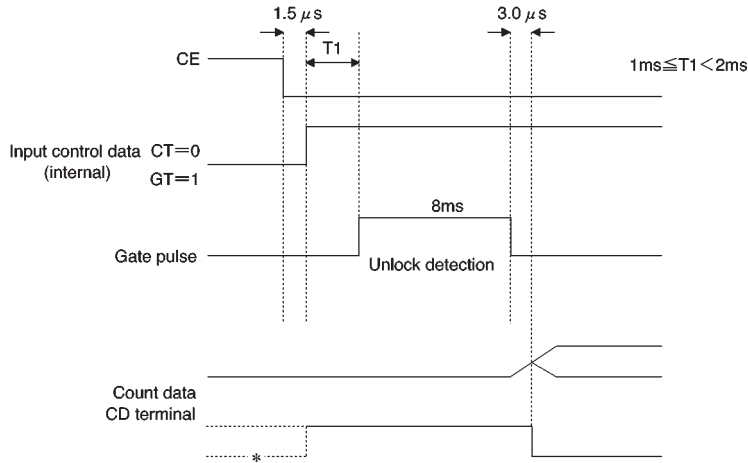

Explanation of CD terminal

When frequency measurement or unlock detection is finished, the CD terminal goes to LO to indicate that the count and unlock detection have finished.

It also synchronizes with CK to output counter data.

When the next data is input, it goes to HI.

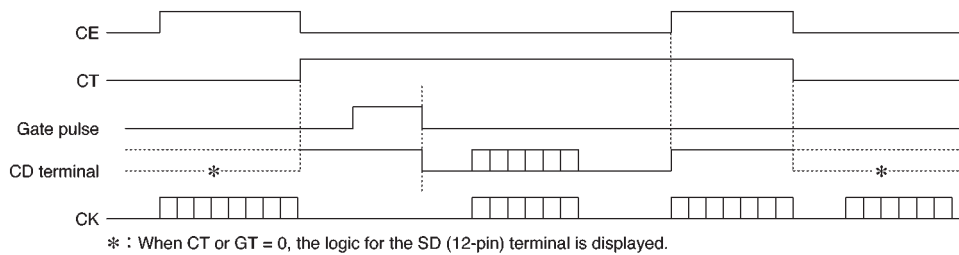

* : When CT or GT = 0, the logic for the SD (12-pin) terminal is displayed.

● External dimensions (Units: mm)

