

UNCONTROLLED DOCUMENT

* PATENT PENDING

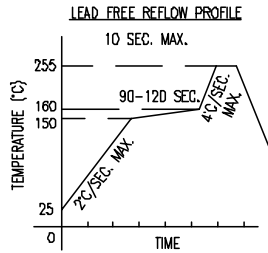

TOTAL TIME ABOVE 220°C IS 60 SECONDS MAX.

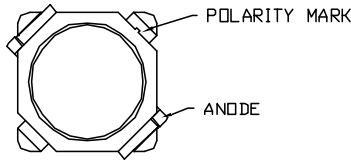
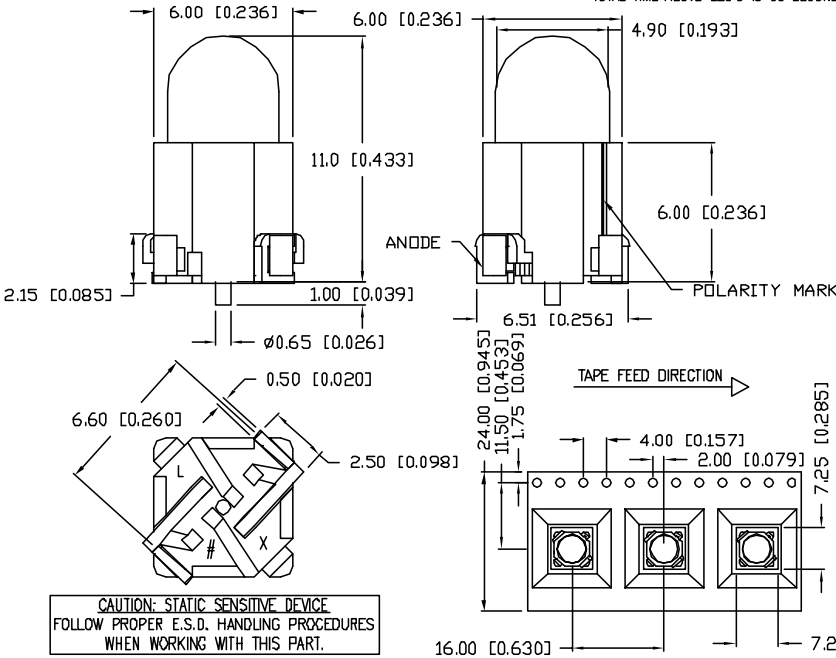

CAUTION: STATIC SENSITIVE DEVICE
FOLLOW PROPER E.S.D. HANDLING PROCEDURES
WHEN WORKING WITH THIS PART.

*UNLESS OTHERWISE SPECIFIED TOLERANCES PER DECIMAL PRECISION ARE: X=±1 (±0.039), XX=±0.5 (±0.025), XXX=±0.25 (±0.010), XXXX=±0.127 (±0.005). LEAD SIZE=±0.05 (±0.002), LEAD LENGTH=±0.75 (±0.030). MIN.=^{+DECIMAL PRECISION}_{-0.00} MAX.=^{+0.00}_{-DECIMAL PRECISION}

PART NUMBER
SML-H1505UWW-TR

REV.

ELECTRO-OPTICAL CHARACTERISTICS $T_A=25^\circ\text{C}$ $I_f=20\text{mA}$

PARAMETER	MIN	TYP	MAX	UNITS	TEST COND
FORWARD VOLTAGE		3.4	3.6	V_f	
REVERSE VOLTAGE	5.0			V_r	$I_f=100\mu\text{A}$
AXIAL INTENSITY	1600	3000		mcd	$I_f=20\text{mA}$
CHROMATICITY X COORDINATES(*1) Y	0.2020 0.1530	-	0.3622 0.3939		
VIEWING ANGLE		40		2x theta	
EMITTED COLOR:	WHITE				
EPOXY LENS FINISH:	WHITE DIFFUSED				

*1. THE ICI STANDARD COLORMETRIC SYSTEM.

LIMITS OF SAFE OPERATION AT 25°C PER DIE

PARAMETER	MAX	UNITS
PEAK FORWARD CURRENT*	100	mA
STEADY CURRENT	30	mA
POWER DISSIPATION	80	mW
DERATE FROM 25°C	-1.2	mW/°C
OPERATING TEMP.	-20 TO +80	°C
STORAGE TEMP.	-30 TO +100	°C
SOLDERING TEMP.	+260	°C
2.0mm FROM BODY		5 SEC. MAX

NOTE:
1. CATHODE IS ORIENTED TOWARDS THE TAPE SPROCKET HOLES.

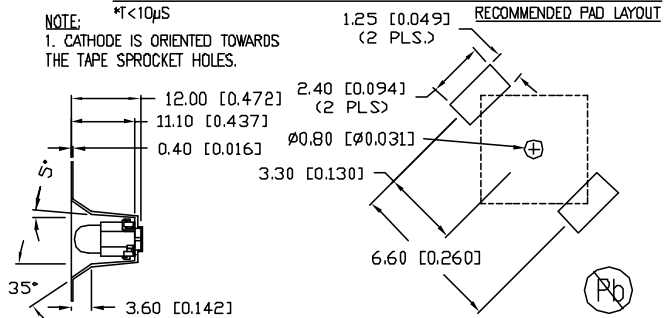

UNCONTROLLED DOCUMENT

REV.	PART NUMBER SML-H1505UWW-TR
5mm SURFACE MOUNTED DOME LED, ULTRA WHITE LED, WHITE DIFFUSED.	

CONFIDENTIAL INFORMATION
THE INFORMATION CONTAINED IN THIS DOCUMENT IS THE PROPERTY OF LUMEX INC. EXCEPT AS SPECIFICALLY AUTHORIZED IN WRITING BY LUMEX INC., THE HOLDER OF THIS DOCUMENT SHALL KEEP ALL INFORMATION CONTAINED HEREIN CONFIDENTIAL AND SHALL PROTECT SAME IN WHOLE OR IN PART FROM DISCLOSURE AND DISSEMINATION TO ALL THIRD PARTIES.

RELIABILITY NOTE
OUR MANY YEARS OF EXPERIENCE DATA ACCUMULATION INDICATE THAT SOLDER HEAT IS A MAJOR CAUSE OF EARLY AND FUTURE FAILURE. PLEASE PAY ATTENTION TO YOUR SOLDERING PROCESS.

290 E. HELEN ROAD
PALATINE, IL 60067-6976
PHONE: +1.847.359.2790
US WEB: www.lumex.com
TW WEB: www.lumex.com.tw

DRAWN BY: JN	CHECKED BY:	APPROVED BY:	DATE: 03.31.08 PAGE: 1 OF 1 SCALE: N/A
-----------------	-------------	--------------	--