

FLL810IQ-3C

L-Band High Power GaAs FET

FEATURES

- Push-Pull Configuration
- High Power Output: 80W
- High PAE: 50%.
- Excellent Linearity
- Suitable for class AB operation.
- Hermetically Sealed Package

DESCRIPTION

The FLL810IQ-3C is an 80 Watt GaAs FET that employs a push-pull design. This device offers excellent linearity, ease of matching, and greater consistency in covering the frequency band of 2.5 to 2.7 GHz. This new product is uniquely suited for use in MMDS applications as it offers high gain, long term reliability and ease of use.

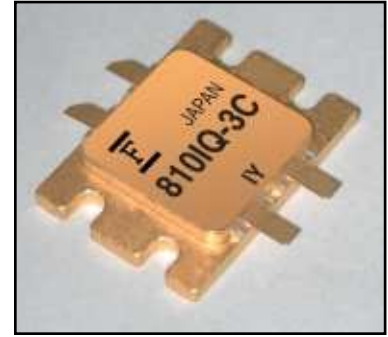

ABSOLUTE MAXIMUM RATINGS (Ambient Temperature Ta=25°C)

Item	Symbol	Condition	Rating	Unit
Drain-Source Voltage	V_{DS}		15	V
Gate-Source Voltage	V_{GS}		-5	V
Total Power Dissipation	P_T	$T_c = 25^\circ\text{C}$	136	W
Storage Temperature	T_{stg}		-65 to +175	°C
Channel Temperature	T_{ch}		+175	°C

Fujitsu recommends the following conditions for the reliable operation of GaAs FETs:

1. The drain-source operating voltage (V_{DS}) should not exceed 12 volts.
2. The forward and reverse gate currents should not exceed 176 and -51.8 mA respectively with gate resistance of 5Ω.
3. The operating channel temperature (T_{ch}) should not exceed 145°C.

ELECTRICAL CHARACTERISTICS (Case Temperature Tc=25°C)

Item	Symbol	Conditions	Limits			Unit
			Min.	Typ.	Max.	
Drain Current	I_{DSS}	$V_{DS} = 5V, V_{GS} = 0V$	-	8	-	A
Pinch-Off Voltage	V_p	$V_{DS} = 5V, I_{DS} = 220mA$	-0.1	-0.3	-0.5	V
Gate-Source Breakdown Voltage	V_{GSO}	$I_{GS} = -2.2mA$	-5	-	-	V
Output Power	P_{out}	$V_{DS} = 12V$ $f = 2.6\text{ GHz}$ $I_{DS} = 5.0A$ $P_{in} = 40.0dBm$	48.0	49.0	-	dBm
Linear Gain (Note 1)	GL		11.0	12.0	-	dB
Power-Added Efficiency	η_{add}		-	50	-	%
Drain Current	I_{DSR}		-	11.5	15.0	A
Thermal Resistance	R_{th}	Channel to Case	-	0.8	1.1	°C/W

CASE STYLE: IQ

Note 1: The condition for GL is the same as Pout except Pin = 25.0dBm.

FLL810IQ-3C

L-Band High Power GaAs FET

OUTPUT POWER vs. FREQUENCY

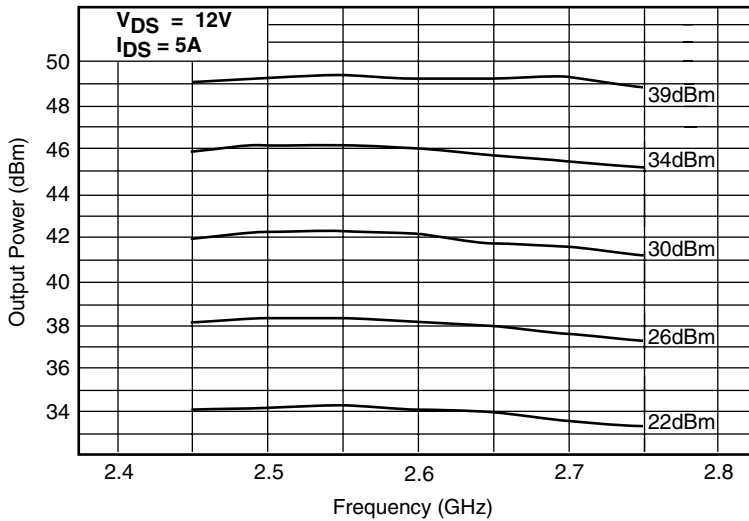

IMD & IDS(RF) vs. TOTAL OUTPUT POWER

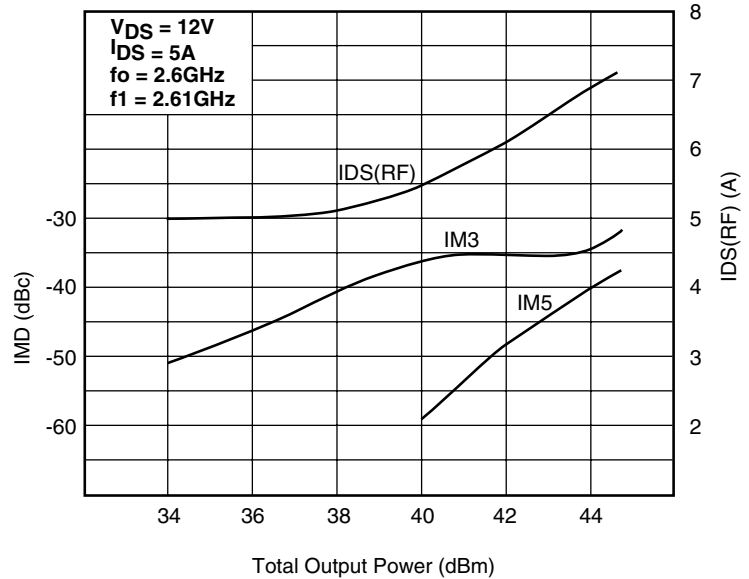

OUTPUT POWER & η_{add} vs. INPUT POWER

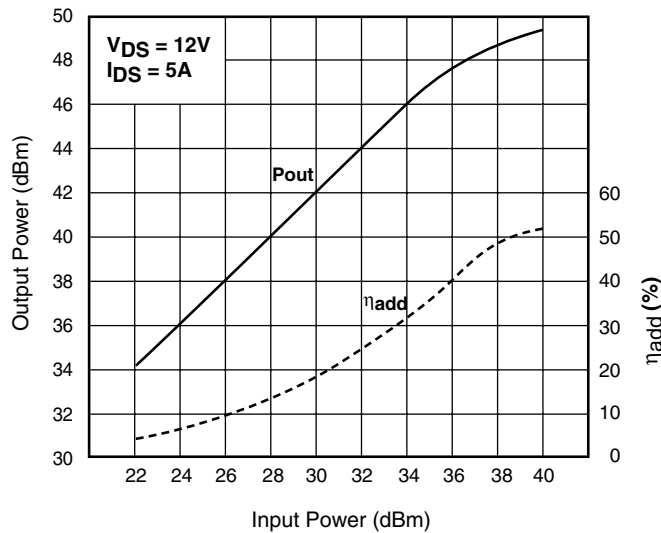

FLL810IQ-3C

L-Band High Power GaAs FET

S-PARAMETERS

$V_{DS} = 12V, I_{DS} = 2500mA$

FREQUENCY (MHZ)	S11		S21		S12		S22	
	MAG	ANG	MAG	ANG	MAG	ANG	MAG	ANG
1500	.856	137.9	1.167	39.2	.021	43.0	.841	167.3
1600	.786	131.5	1.430	25.6	.026	31.2	.805	167.9
1700	.698	124.7	1.722	10.3	.029	15.8	.790	169.2
1800	.579	118.4	2.020	-8.0	.034	0.9	.777	170.2
1900	.455	115.3	2.323	-27.7	.036	-16.4	.795	171.0
2000	.347	115.2	2.564	-48.5	.039	-39.5	.818	169.7
2100	.247	119.8	2.784	-67.9	.041	-59.6	.819	167.1
2200	.141	142.0	3.064	-90.1	.041	-84.9	.781	163.5
2300	.200	-160.2	3.418	-114.9	.039	-114.5	.668	162.4
2400	.425	-159.8	3.446	-143.7	.035	-150.5	.560	170.4
2500	.634	-179.2	3.332	-173.7	.029	170.0	.556	-175.3
2600	.738	156.5	2.845	161.4	.024	122.6	.659	-168.5
2700	.750	129.4	2.436	134.5	.023	84.7	.747	-168.5
2800	.693	94.5	2.125	113.9	.020	47.3	.822	-170.0
2900	.620	48.8	1.618	89.3	.020	12.3	.879	-172.2
3000	.601	0.2	1.345	67.3	.019	-15.0	.910	-175.1
3100	.713	-39.5	1.031	50.9	.017	-35.8	.931	-177.6
3200	.804	-68.6	.748	31.0	.014	-60.2	.922	-179.8
3300	.863	-89.7	.587	19.4	.015	-70.4	.936	178.2
3400	.895	-104.3	.420	9.2	.014	-85.8	.936	176.2
3500	.909	-115.6	.335	0.5	.009	-96.7	.951	174.2

Note: This S-Parameter data shows measurements performed on a single-ended push-pull FET. These parameters should be used to determine the calculated Push-Pull S-Parameter amplifier designs.

[Download S-Parameters, click here](#)

FLL810IQ-3C

L-Band High Power GaAs FET

Case Style "IQ"

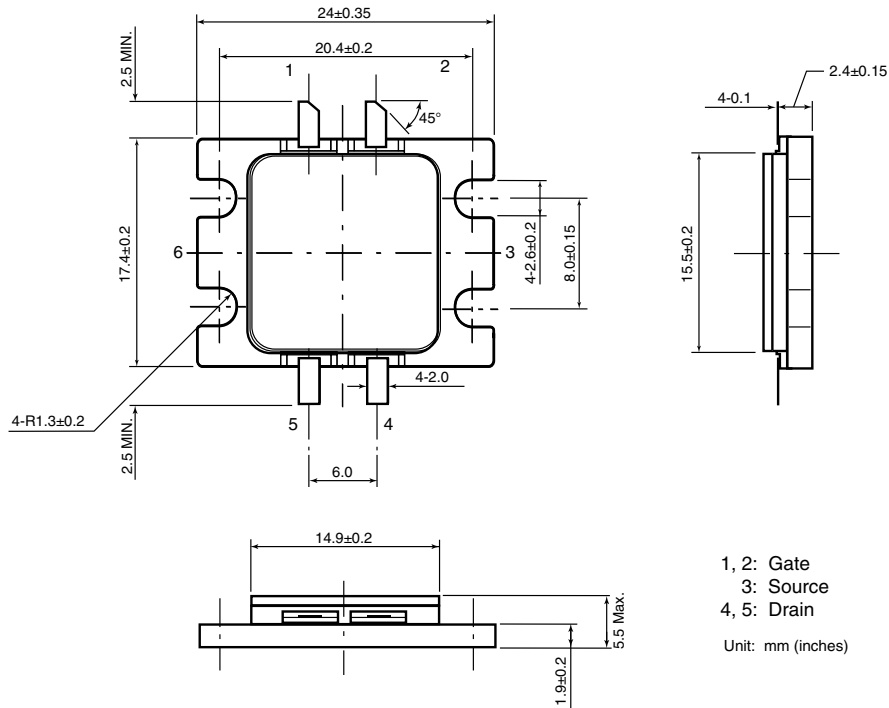

For further information please contact:

FUJITSU COMPOUND SEMICONDUCTOR, INC.

2355 Zanker Rd.
San Jose, CA 95131-1138, U.S.A.
Phone: (408) 232-9500
FAX: (408) 428-9111
www.fcsi.fujitsu.com

FUJITSU QUANTUM DEVICES EUROPE LTD.

Network House
Norreys Drive
Maidenhead, Berkshire SL6 4FJ
Phone: +44 (0)1628 504800
FAX: +44 (0)1628 504888

CAUTION

Fujitsu Compound Semiconductor Products contain **gallium arsenide (GaAs)** which can be hazardous to the human body and the environment. For safety, observe the following procedures:

- Do not put these products into the mouth.
- Do not alter the form of this product into a gas, powder, or liquid through burning, crushing, or chemical processing as these by-products are dangerous to the human body if inhaled, ingested, or swallowed.
- Observe government laws and company regulations when discarding this product. This product must be discarded in accordance with methods specified by applicable hazardous waste procedures.

Fujitsu Limited reserves the right to change products and specifications without notice.
The information does not convey any license under rights of Fujitsu Limited or others.
© 2001 FUJITSU COMPOUND SEMICONDUCTOR, INC.
Printed in U.S.A. FCSI05019M200

