

NPN SILICON RF TRANSISTOR

DESCRIPTION:

The **ASI MRF951** is Designed for high gain. Low noise small-signal amplifiers. Applications up to 2.0 GHz.

FEATURES:

- Low Noise Figure
- High Gain
- **Omnigold™** Metalization System

MAXIMUM RATINGS

I_C	100 mA
V_{CBO}	20 V
V_{CEO}	10 V
V_{EBO}	1.5 V
P_{DISS}	1.0 W @ $T_C = 25\text{ }^\circ\text{C}$
T_J	-65 $^\circ\text{C}$ to +150 $^\circ\text{C}$
T_{STG}	-65 $^\circ\text{C}$ to +150 $^\circ\text{C}$
θ_{JC}	100 $^\circ\text{C}/\text{W}$

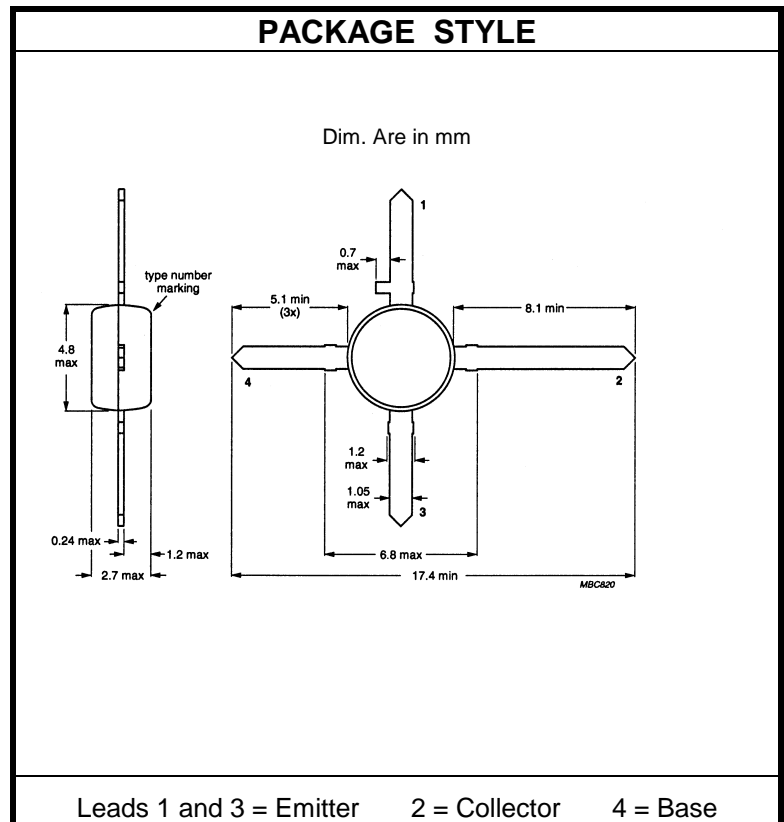
CHARACTERISTICS $T_C = 25\text{ }^\circ\text{C}$

SYMBOL	TEST CONDITIONS			MINIMUM	TYPICAL	MAXIMUM	UNITS
BV_{CBO}	$I_C = 0.1\text{ mA}$			20			V
BV_{CEO}	$I_C = 0.1\text{ mA}$			10			V
I_{CBO}	$V_{CB} = 10\text{ V}$					0.1	μA
I_{EBO}	$V_{EB} = 1.0\text{ V}$					0.1	μA
h_{FE}	$V_{CE} = 6.0\text{ V}$	$I_C = 5.0\text{ mA}$		50		200	---
C_{cb}	$V_{CB} = 10\text{ V}$	$f = 1.0\text{ MHz}$			0.45		pF
G_{NF}	$V_{CE} = 6.0\text{ V}$	$I_C = 5.0\text{ mA}$	$f = 1.0\text{ GHz}$		14		dB
			$f = 2.0\text{ GHz}$		9.0		
$NF_{50\Omega}$	$V_{CE} = 6.0\text{ V}$	$I_C = 5.0\text{ mA}$			1.9	2.8	dB