

## PROGRAMMABLE CALCULATOR WITH 10-BIT DUAL DISPLAY

### DESCRIPTION

The SC3449 is a monolithic CMOS circuit for scientific calculators, having the basic calculation, the memory calculation, fraction calculation, percentage calculation, scientific function calculation, statistics back to return to compute, degree, cent, second calculation etc. ,and you can directly press the key according to the sequence of the formulas, while the calculators will automatically operate in terms of the algorithm. Using a 3V power supply it can display ten arithmetic figures, 12 characters composing of lattice, and the state mark of the calculation. The calculator can turn off by itself.

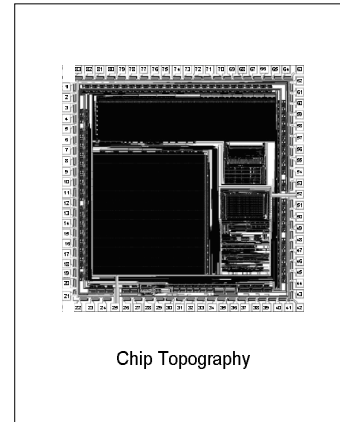

### FEATURES

- \* Monolithic CMOS structure
- \* Scientific operation
- \* Statistic operation
- \* Fraction operation
- \* Coordinate transform
- \* Conversion and operation between Decimal and hex
- \* Editing input operation
- \* Independent memory M
- \* Memories A, B, C, D, E, F, X, Y
- \* Producing stochastic numbers
- \* Register "ANS" for final answers
- \* 3V typical power supply
- \* 43uA typical power dissipation
- \* 32kx8bit built-in large capacitance program ROM
- \* Embedded microprogramming control
- \* Showing the electricity-saving mode
- \* Turnoff automatically
- \* 83-pin COB package
- \* Calculation range:  $\pm 10^{-99} \sim \pm 9.999999999 \times 10^{99}$

### ORDERING INFORMATION

Device	Package
SC3449	DIE

### APPLICATIONS

- \* Science function calculators

**BLOCK DIAGRAM**

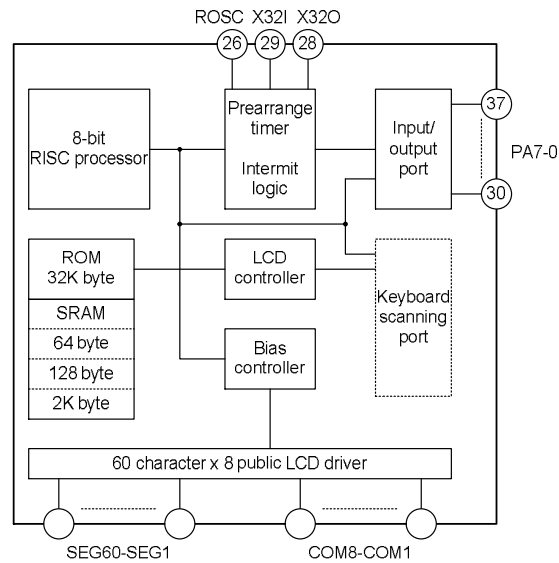

**ABSOLUTE MAXIMUM RATINGS**

Characteristics	Symbol	Rating	Unit
DC Power Supply	VDD	< 6	V
Input Voltage	VIN	-0.5 ~ VDD + 0.5	V
Operation Temperature	Tamb	0 ~ +60	°C
Storage Temperature	TSTO	-50 ~ +150	°C

Note: Error or device damaging will occur when the value is over these absolute maximum ratings. Normal operation parameter is to see AC/DC electrical parameter.

**DC ELECTRICAL CHARACTERISTICS** (Tamb = 25 °C, VDD = 3 V)

Characteristics	Symbol	Test Condition	Min.	Typ.	Max.	Unit
Operating Voltage	VDD	2 batteries	2.4	-	3.6	V
Operating Current	IOP	FCPU = 500KHz @ 3V, no key-press	-	35	-	μA
standby Current	ISTBY	VDD = 3V, 32768Hz OFF, ROSC OFF	-	0	0.1	μA
Input High Level	VIH	VDD = 3V	2.0	-	-	V
Input Low Level	VIL	VDD = 3V	-	-	0.8	V
Output High Current (PA5 - 0)	IOH	VDD = 3V VOH = 2V	-	1.0	-	mA
Output Sink Current (PA5 - 0)	IOL	VDD = 3V VOL = 1V	-	-1.0	-	mA

(To be continued)

(Continued)

Characteristics	Symbol	Test Condition	Min.	Typ.	Max.	Unit
Output High Current (PA7 - 6)	IOH	VDD = 3V VOH = 2V	-	2.5	-	mA
Output Sink Current (PA7 - 6)	IOL	VDD = 3V VOL = 1V	-	-2.5	-	mA
Oscillator Resistor	Rosc	FCPU = 500KHz @ 3V	-	350	-	KΩ
CPU Clock frequency	FCPU	VDD = 3V	-	-	1.0	MHz

### PIN CONFIGURATION

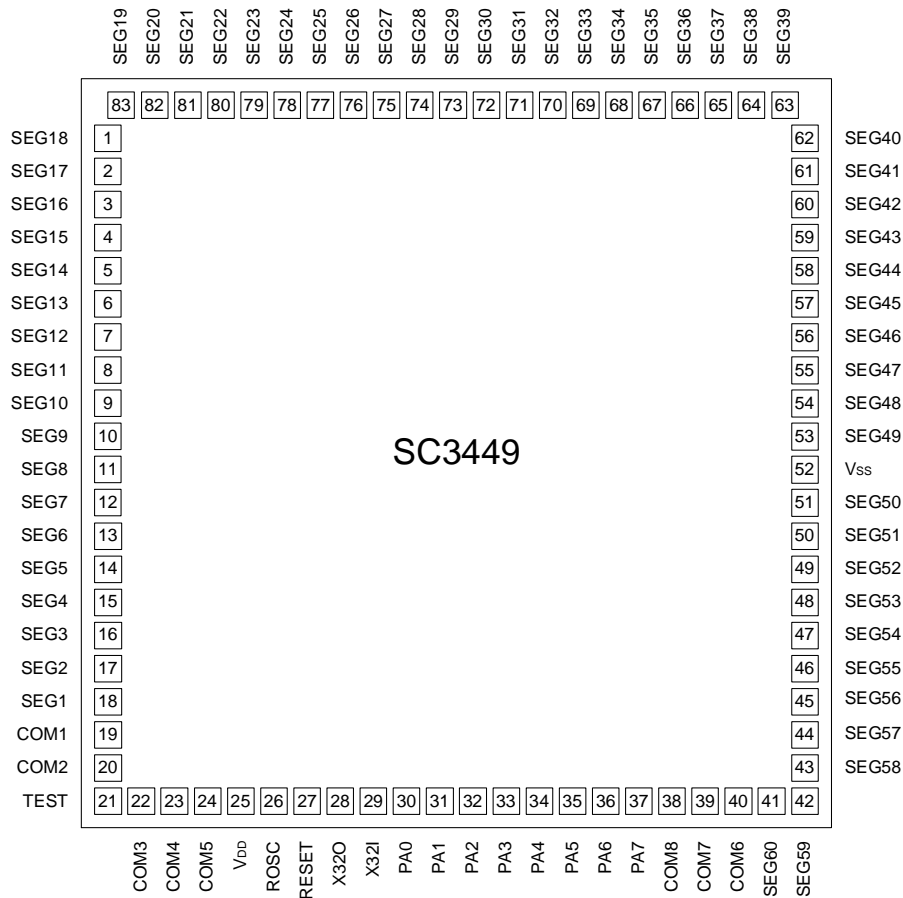

### PIN DESCRIPTION

Pin No.	Pin name	Pin description
25	VDD	Power supply input
52	VSS	Ground input
27	RESET	System reset input (internal pull-up) , low active

(To be continued)

(Continued)

Pin No.	Pin name	Pin description
21	TEST	Testing input (internal pull-down) , high active
29	X32I	32.768KHz crystal oscillator input <sup>[note]</sup>
28	X32O	32.768KHz crystal oscillator output
26	ROSC	R oscillator input, connect to VDD by a resistor
37 ~ 30	PA7 ~ 0	Input/output port
38 ~ 40 24 ~ 22 20 ~ 19	COM8 ~ COM6 COM5 ~ COM3 COM2 ~ COM1	LCD common output
41 ~ 51 53 ~ 83 1 - 18	SEG60 ~ SEG50 SEG49 ~ SEG19 SEG18 ~SEG1	LCD segment output <sup>[note]</sup>

Note: The 32kHz crystal oscillation of the chip is gained by Rosc frequency detaching, therefore no need to add a 32768Hz crystal oscillator outside, the pin X32I should attach to Vss, pin X32O hang in the air.

The CMOS chip has already enacted seg8~seg1 to input by reusing the keys simultaneously. That is besides the LCD display, it can also be as input keys combining with Pa7~Pa1.

## FUNCTION DESCRIPTION

### 1. Calculator function

#### 1. LCD display

Screen with dual row display. See the LCD display screen sketch map on the seventh section.

The first row shows the formulas that are input by 6\*5 lattice display.

The second row shows the calculating results.

The bottom shows the mark of the calculating state.

#### 2. Calculation mode

Application	Mode name	Mode directional symbol
<b>Calculation mode</b>		
General calculation	COMP	
Standard tolerance calculation	SD	SD
Regression calculation	REG	REG
<b>Angle unit mode</b>		
Degree	DEG	D
Radian	RAD	R
Centigrade	GRA	G
<b>Display mode</b>		
Exponent display (cancel the decimal fraction (FIX) and efficient digits enactment (SCI))	NORM1 NORM2	
Decimal digits enactment	FIX	Fix
Efficient digits enactment	SCI	Sci











Note:

- Calculation mode directional symbol will show at the bottom of the display screen.
- General computing (COMP), standard tolerance calculation (SD) and regression calculation (REG) can be used together with the angle unit mode.
- You should check the actual calculation and angle mode to see whether they are according with the requirement every time before a calculation.





### **3. Input limit**

The storage area used to memorize the calculation program can memory 79 steps. When input the 73<sup>rd</sup> step, the cursor will change from “\_” to “■”. This indicates the enacted storage capacity area is not enough. And if you need to input more things, please divide the calculation into two or more operation section.



### **4. Input error revising**

- Use  or  to move the cursor to the place where you want to revise.
- Use  to remove the numbers or functions at the present cursor.
- Press   and the cursor will flicker “[ ]”, that is to say it has already enters the inserting state. In this state, the input characters will insert the place where the present cursor is.
- Press , ,   or , the cursor will come back to the common state from the inserting state.







### **5. Recurrence function**

- Press  or  to show the last calculation in the display interface, and you can amend the content of the formulas to calculate over again.
- The content of the recurrence memory won't be cleared if you press the key . So you can also make use of the last calculation result even you press the key .
- It will clear the recurrence memory every time when to begin a new calculation、to change the calculation state or shut off the power supply.

### **6. Error indicator**

When the calculation error appears, press  or  and the cursor will stay where the error is.

### **7. Exponent display method**

The calculator shows ten digits at most. When above ten digits, it will automatically use the exponent display method. For decimal fraction, you can choose one from the two methods to appoint when to use the exponential form. Press      (or ) to choose form NORM1 or NORM2.

#### **• NORM1**



When use NORM1, for the integer above 10 digits or the decimal fraction digits above 2, it will adopt the exponential form.

#### **• NORM2**

When use NORM2, for the integer above 10 digits or the decimal fraction digits above 9, it will adopt the exponential form.

- All the examples in the instruction use NORM1 to denote the calculation result.

### **8. Answer memory**

Every time you press the key  after you input the numerical value or formulas, the calculation result will keep into the answer memory automatically. And press  to show the content in the answer memory.

- The answer memory can memory mantissa of 12 digits and exponent of 2 digits.

- If the calculation result is wrong (ERROR) after the above operation, the value in the answer memory will not be updated.

## 2. Calculation and demonstration

Note: The key-press expression is circled by the outline border and the input number is not.

### 1. Basic calculation

Use COMP mode to carry out the basic calculation

	Arithmetic formula	Key-press	Result vision
Example1	$3 \times (5 \times 10^{-9})$	3 $\times$ ( 5 EXP (-) 9 ) =	$1.5^{-08}$
Example2	$5 \times (9 + 7)$	5 $\times$ ( 9 + 7 ) =	80.

- The key operation  $\boxed{\text{M}}$  before the equal mark  $\boxed{=}$  can be omitted.

### 2. Memory calculation

Independent memory

- The numerical value can be directly kept into the memory, and it can add to the numerical value in the memory. It can also subtract the numerical value from the memory. The independent memory is convenient for cumulating the sum.
- The memory area used by variable M is the same as that used by the independent memory.
- If you want to clear the numerical value in the independent memory, press  $\boxed{\text{SHIFT}} \boxed{\text{MCl}} \boxed{=}$  or  $0 \boxed{\text{STO}} \boxed{\text{M}}$ .

	Arithmetic formula	Key-press	Result vision
Example	$23 + 9 = 32$	23 $+$ 9 $\boxed{\text{STO}} \boxed{\text{M}}$	32.
	$53 - 6 = 47$	53 $-$ 6 $\boxed{\text{M}+}$	47.
	$-)45 \times 2 = 90$	45 $\times$ 2 $\boxed{\text{SHIFT}} \boxed{\text{M}+}$	90.
	(sum) $-11$	$\boxed{\text{RCL}} \boxed{\text{M}}$	-11.

Variable

- The calculator stocks 9 variables(A to F, M, X and Y) that can memory data, constants, calculation results and other numerical values.
- Using the operation  $\boxed{\text{SHIFT}} \boxed{\text{MCl}} \boxed{=}$  you can delete all the data of 9 variables.
- Using the following operation can delete the data given to some variable:  $0 \boxed{\text{STO}} \boxed{\text{A}}$ . The operation will delete the data of variable A.

	Arithmetic formula	Key-press	Result vision
Example	$193.2 \div 23 = 8.4$	193.2 $\boxed{\text{STO}} \boxed{\text{A}}$ $\boxed{\div}$ 23 $\boxed{=}$	8.4
	$193.2 \div 28 = 6.9$	$\boxed{\text{ALPHA}} \boxed{\text{A}}$ $\boxed{\div}$ 28 $\boxed{=}$	6.9

### 3. Fraction calculation

Fraction calculation

- Use COMP mode to go along the fraction operation.
- When the summation of the fraction digits (integer + numerator + denominator + semicolon) is above 10 digits, the calculator will automatically show this numerical value in the decimal fraction form.

	Arithmetic formula	Key-press	Result vision
Example 1	$\frac{2}{3} + 1\frac{4}{5}$	2 $\boxed{\frac{a}{b/c}}$ 3 $\boxed{+}$ 1 $\boxed{\frac{a}{b/c}}$ 4 $\boxed{\frac{a}{b/c}}$ 5 $\boxed{=}$	$2\_ 7\_ 15.$
Example 2	$\frac{1}{2} + 1.6$	1 $\boxed{\frac{a}{b/c}}$ 2 $\boxed{+}$ 1.6 $\boxed{=}$	2.1

- The mixed calculation of fraction/decimal fraction will be shown in the decimal fraction form.

Transform the decimal fraction form to fraction form

	Arithmetic formula	Key-press	Result vision
Example	$2.75 \rightarrow 2\frac{3}{4}$	2.75 [=] a b/c SHIFT d/c	2.75 2_3_4. 11_4.

Transform the fraction form to fraction form decimal fraction

	Arithmetic formula	Key-press	Result vision
Example	$\frac{1}{2} \leftrightarrow 0.5$ (Fraction↔Decimal fraction)	1 a b/c 2 = a b/c a b/c	1_2. 0.5 1_2.

- Please use parenthesis() in combinational arithmetics between function ( A function, B function, power and root operation etc.)and fraction operator ab/c.

	Arithmetic formula	Key-press	Result vision
Example 1	$\sin \frac{8}{5}$	Sin ( 8 a b/c 5 ) =	Sin(8_5)=0.027921638
Example 2	$\frac{\sin 8}{5}$	( Sin 8 ) a b/c 5 =	(Sin8)_5=0.02783462

#### 4. Percentage calculation

- Use COMP mode to go along the percentage calculation

	Arithmetic formula	Key-press	Result vision
Example 1	Calculating the12% of 1500	1500 x 12 SHIFT % =	180.
Example 2	What percent is 660 of 880	660 ÷ 880 SHIFT % =	75.

#### 5. Science function calculation

- Use COMP mode to go along the science function calculation
- $\pi=3.14159265359$

Trigonometric /counter-trigonometric function

	Arithmetic formula	Key-press	Result vision
Example1	$\sin 63^\circ 52'41''$	MODE MODE 1 → "D" Sin 63 ° ' 52 ° ' 41 ° ' =	0.897859012
Example2	$\cos(\frac{\pi}{3} \text{ rad})$	MODE MODE 2 → "R" Cos ( ( SHIFT π ÷ 3 ) ) =	0.5
Example3	$\cos^{-1} \frac{\sqrt{2}}{2} = \frac{\pi}{4}$	MODE MODE 2 → "R" SHIFT cos <sup>-1</sup> ( ( √ 2 ÷ 2 ) ) = Ans ÷ SHIFT π =	0.785398163 0.25
Example4	$\tan^{-1} 0.741$	MODE MODE 1 → "D" SHIFT tan <sup>-1</sup> 0.741 =	36.53844577

*Hyperbolic/counter-hyperbolic function*

	Arithmetic formula	Key-press	Result vision
Example1	Sinh 3.6	Hyp Sin 3.6 =	18.28545536
Example2	sinh-130	Hyp SHIFT sin-1 30 =	4.094622224

*Angle unit counterchange*

Please press **SHIFT** **DRG** **▶** to pick up the menu on the display screen.

D	R	G
1	2	3

Press 1, 2 or 3 to choose the angle unit corresponding to the showing numerical value.

	Arithmetic formula	Key-press	Result vision
Example	Transfer 4.25 radian into degree	<b>MODE</b> <b>MODE</b> 1 → "D" 4.25 <b>SHIFT</b> <b>DRG</b> <b>▶</b> 2(R) =	4.25' 243.5070629

*Common and natural logarithm/inverse logarithm*

	Arithmetic formula	Key-press	Result vision
Example1	Log1.23	<b>Log</b> 1.23 =	0.089905111
Example2	Ln90	<b>Ln</b> 90 =	4.49980967
Example3	$e^{10}$	<b>SHIFT</b> <b>e<sup>x</sup></b> 10 =	22026.46579
Example4	$10^{1.5}$	<b>SHIFT</b> <b>10<sup>x</sup></b> 1.5 =	31.6227766
Example5	$2^4$	2 <b>x<sup>y</sup></b> 4 =	16.

*Square root, cube root, root, square, cube, reciprocal, factorial, stochastic number and pi*

	Arithmetic formula or requirement	Key-press	Result vision
Example1	$\sqrt{2} + \sqrt{3} \times \sqrt{5}$	<b>√</b> 2 <b>+</b> <b>√</b> 3 <b>×</b> <b>√</b> 5 =	5.287196908
Example2	$\sqrt[3]{5} + \sqrt[3]{-27}$	<b>∛</b> 5 <b>+</b> <b>∛</b> (-) 27 =	-1.290024053
Example3	$\sqrt[7]{123} (= 123^{\frac{1}{7}})$	7 <b>SHIFT</b> <b>∛</b> 123 =	1.988647795
Example4	$123+30^2$	123 <b>+</b> 30 <b>x<sup>2</sup></b> =	1023.
Example5	$12^3$	12 <b>x<sup>3</sup></b> =	1728.
Example6	$\frac{1}{\frac{1}{3} - \frac{1}{4}}$	<b>(</b> 3 <b>x<sup>1</sup></b> <b>-</b> 4 <b>x<sup>1</sup></b> <b>)</b> <b>x<sup>-1</sup></b> =	12.
Example7	8!	8 <b>SHIFT</b> <b>x!</b> =	40320.
Example8	Producing a stochastic number between 0.000 and 0.999	<b>SHIFT</b> <b>Ran#</b> =	(For example, the result every time is different) 0.526
Example9	$3\pi$	3 <b>SHIFT</b> <b>π</b> =	9.424777961



*Decimal digits, efficient digits, RND*

	Arithmetic formula or requirement	Key-press	Result vision
Example1	200÷7×14=400 (appointed 3 digits decimal fraction) (Calculating the internal data are unchangeable)	200 $\div$ 7 $\times$ 14 $=$	400.
		$\text{MODE}$ $\text{MODE}$ $\text{MODE}$ 1 3	400.000 Fix
		200 $\div$ 7 $=$ $\times$ 14 $=$	28.571 400.000

*Going along the same calculation by appointed decimal digits.*

	Arithmetic formula or requirement	Key-press	Result vision
Example2	(Calculating the internal rounding)	200 $\div$ 7 $=$	28.571
		$\text{SHIFT}$ $\text{Rnd}$	28.571
		$\times$ 14 $=$	399.994

- Pressing  $\text{MODE}$   $\text{MODE}$   $\text{MODE}$  3 1 can delete the enactment of the decimal digits (FIX)

	Arithmetic formula or requirement	Key-press	Result vision
Example3	1÷3 Showing the calculation result by two efficient digits (SCI 2)	$\text{MODE}$ $\text{MODE}$ $\text{MODE}$ 2 2 1 $\div$ 3 $=$	3.3 <sup>-01</sup> Sci

- Pressing  $\text{MODE}$   $\text{MODE}$   $\text{MODE}$  3 1 can delete the enactment of the efficient digits.

*Engineering calculation*

	Arithmetic formula	Key-press	Result vision
Example1	Converse 56, 088 meter to kilometer	56088 $=$ $\text{ENG}$	56.088 <sup>-03</sup>
Example2	Converse 0.08125 gram to milligram	0.08125 $=$ $\text{ENG}$	81.25 <sup>-03</sup>

*Coordinate transform*

- The result will assign the variable E and F automatically

	Arithmetic formula or requirement	Key-press	Result vision	Note
Example1	Transfer the polar coordinates (r=2, $\theta=60^\circ$ ) to right-angle coordinates (x, y). (DEG mode)	$\text{SHIFT}$ $\text{Rec}$ 2 , 60 $)$ $=$	1. D	x
		$\text{RCL}$ $\text{F}$	1.732050808	y

- Pressing  $\boxed{\text{RCL}} \boxed{\text{E}}$  ,  $\boxed{\text{RCL}} \boxed{\text{F}}$  can make the numerical value replace the present showing numerical value.

	Arithmetic formula or requirement	Key-press	Result vision	Note
Example2	Transfer the right-angle coordinates $(1, \sqrt{3})$ to polar coordinates $(r, \theta)$ . (RAD state)	$\boxed{\text{Pol}} \boxed{1} \boxed{.} \boxed{\sqrt{}} \boxed{3} \boxed{)} \boxed{=}$ $\boxed{\text{RCL}} \boxed{\text{F}}$	2. R 1.047197551	r  $\theta$

- Pressing  $\boxed{\text{RCL}} \boxed{\text{E}}$  ,  $\boxed{\text{RCL}} \boxed{\text{F}}$  can make the numerical value replace the present showing numerical value.

#### Permutation

	Arithmetic formula or requirement	Key-press	Result vision
Example	Using numbers from 1 to 7 can compose how many different four digits numbers, and the value of them can not repeat.(1234 is admitted, but 1123 is not)	$7 \boxed{\text{SHIFT}} \boxed{\text{nPr}} \boxed{4} \boxed{=}$	840.

#### Combination

	Arithmetic formula or requirement	Key-press	Result vision
Example	Take 4 things among 10, asking how many combinations can be composed.	$10 \boxed{\text{nCr}} \boxed{4} \boxed{=}$	210.

### 6. Statistics calculation

#### Standard deviation (SD mode)

- Press  $\boxed{\text{MODE}} \boxed{2}$  to enter the SD state, and go along the statistics calculation using standard deviation.
- Please press  $\boxed{\text{SHIFT}} \boxed{\text{ScI}} \boxed{=}$  at first without fail to clear the statistics memory before input the data.
- The input data are used to calculate the value of  $n$ ,  $\sum x^2$ ,  $\sum x$ ,  $\bar{x}$ ,  $\sigma_n$ ,  $\sigma_{n-1}$ , you can use the demonstrational operation in the right diagram to calculate.

$\boxed{\text{RCL}} \boxed{\text{A}}$	$\sum x^2$
$\boxed{\text{RCL}} \boxed{\text{B}}$	$\sum x$
$\boxed{\text{RCL}} \boxed{\text{C}}$	$n$
$\boxed{\text{SHIFT}} \boxed{\bar{x}}$	$\bar{x}$
$\boxed{\text{SHIFT}} \boxed{\sigma_n}$	$\sigma_n$
$\boxed{\text{SHIFT}} \boxed{\sigma_{n-1}}$	$\sigma_{n-1}$

	Arithmetic formula or requirement	Key-press	Result vision
Example	Answer for the data $\sigma_{n-1}$ , $\sigma_n$ , $\bar{x}$ , $n$ , $\sum x$ , $\sum x^2$ : 55, 54, 51, 55, 53, 53, 54, 52	55 $\overline{DT}$ 54 $\overline{DT}$ 51 $\overline{DT}$ 55 $\overline{DT}$ 53 $\overline{DT}$ $\overline{DT}$ 54 $\overline{DT}$ 52 $\overline{DT}$	52. SD
	(Sample standard deviation $\sigma_{n-1}$ )	$\overline{SHIFT}$ $\overline{x\sigma_{n-1}}$ $\overline{=}$	1.407885953
	(Collectivity standard deviation $\sigma_n$ )	$\overline{SHIFT}$ $\overline{x\sigma_n}$ $\overline{=}$	1.316956719
	(Arithmetic average value $\bar{x}$ )	$\overline{SHIFT}$ $\overline{x}$ $\overline{=}$	53.375
	(The numbers of the datan)	$\overline{RCL}$ $\overline{C}$ $\overline{=}$	8.
	(Sum $\sum x$ )	$\overline{RCL}$ $\overline{B}$ $\overline{=}$	427.
	(square sum $\sum x^2$ )	$\overline{RCL}$ $\overline{A}$ $\overline{=}$	22805.

Notice when input data:

- Pressing  $\overline{DT}$   $\overline{DT}$  can input the same data twice.
- Using  $\overline{SHIFT}$   $\overline{;}$  you can input the same data time after time. For example, if you want to input 100 ten times, you can press 110  $\overline{SHIFT}$   $\overline{;}$  10  $\overline{DT}$
- The above result can be required in arbitrary order not necessarily in the above order.
- If you need to delete the just inputting data, you can press  $\overline{SHIFT}$   $\overline{CL}$ .

Regression calculation (Regression REG state)

- Press  $\overline{MODE}$  3 to enter the regression (REG) state, and then choose one type among the following regression types to go along the regression calculation.

- 1 : Linearity regression
- 2 : Logarithm regression
- 3 : Exponent regression

- $\overline{▶}$  1 : Power regression
- $\overline{▶}$  2 : Reverse regression
- $\overline{▶}$  3 : Quadratic regression

- Please press  $\overline{SHIFT}$   $\overline{ScI}$   $\overline{=}$  at first without fail to clear the statistics memory before you input the data.
- The result of the regression calculation decided by the input numerical value can be take out according to the demonstrational operation in the following diagram.

$\overline{RCL}$ $\overline{A}$	$\sum x^2$	$\overline{SHIFT}$ $\overline{x\sigma_{n-1}}$	$x\sigma_{n-1}$
$\overline{RCL}$ $\overline{B}$	$\sum x$	$\overline{SHIFT}$ $\overline{y}$	$\overline{y}$
$\overline{RCL}$ $\overline{C}$	$n$	$\overline{SHIFT}$ $\overline{y\sigma_n}$	$y\sigma_n$
$\overline{RCL}$ $\overline{D}$	$\sum y^2$	$\overline{SHIFT}$ $\overline{y\sigma_{n-1}}$	$y\sigma_{n-1}$
$\overline{RCL}$ $\overline{E}$	$\sum y$	$\overline{SHIFT}$ $\overline{A}$	Regression coefficient A
$\overline{RCL}$ $\overline{F}$	$\sum xy$	$\overline{SHIFT}$ $\overline{B}$	Regression coefficient B
$\overline{RCL}$ $\overline{M}$	$\sum x^3$	$\overline{SHIFT}$ $\overline{C}$	Regression coefficient C
$\overline{RCL}$ $\overline{X}$	$\sum x^2 y$	$\overline{SHIFT}$ $\overline{I}$	Regression coefficient $\hat{x}$
$\overline{RCL}$ $\overline{Y}$	$\sum x^4$	$\overline{SHIFT}$ $\overline{\hat{x}}$	$\hat{y}$
$\overline{SHIFT}$ $\overline{x}$	$\bar{x}$	$\overline{SHIFT}$ $\overline{\hat{y}}$	
$\overline{SHIFT}$ $\overline{x\sigma_n}$	$x\sigma_n$		

- Linearity regression
- The linearity regression formula is  $y=A+B x$
- Example: the air pressure: air temperature

Go along the linearity regression calculation in the left diagram and answer the constant and relevant coefficient. Then estimate the air pressure when the temperature is 18°C and the air temperature when the air pressure is 1000 hPa.

Air temperature x	Air pressure y
10°C	1003 hPa
15°C	1005 hPa
20°C	1010 hPa
25°C	1011 hPa
30°C	1014 hPa

- Please input the data< air temperature x data, air pressure y data> DT according to the following format. DT

	Requirement or operation	Key-press	Result vision
Example	Enter the regression (REG) mode	MODE 3 1 SHIFT [Sc] =	
	(Linearity regression)	10 [.] 1003 [DT] 15 [.] 1005 [DT]	0.
	(Clear the memory)	20 [.] 1010 [DT] 25 [.] 1011 [DT]	
	(Input data)	30 [.] 1014 [DT]	
	(Regression coefficient A)	SHIFT [A] =	30. 997.4
	(Regression coefficient B)	SHIFT [B] =	0.56 0.982607369
	(Correlative coefficient r)	SHIFT [r] =	1007.48
	(Air pressure at 18°C)	18 [SHIFT] [y]	4.642857143
(Air temperature at 1000hPa)	1000 [SHIFT] [x]		

- Quadratic regression

The regression formula of quadratic regression is:

$$y = A + Bx + Cx^2$$

Using the data in the right diagram to go along the quadratic regression and ask for the every regression coefficient in the formula. Then using this regression formula estimate the value of  $\hat{y}$  when  $x_i=16$  (The estimate value of y) and the value of  $\hat{x}$  when (The estimate value of x)

$x_i$	$y_i$
29	1.6
50	23.5
74	38.0
103	46.4
118	48.0

	Requirement	Key-press	Result vision	
Example	Enter the regression (REG) mode (Quadratic regression) (Clear the memory) (Input data)	MODE 3 $\blacktriangleright$ 3 SHIFT $\square$ $\square$ 29 $\square$ 1.6 $\square$ 50 $\square$ 23.5 $\square$ 74 $\square$ 38.0 $\square$ 103 $\square$ 46.4 $\square$ 118 $\square$ 48.0 $\square$		0.
	(Regression coefficient A)	SHIFT A $\square$	118. -	
	(Regression coefficient B)	SHIFT B $\square$	35.5985693	
	(Regression coefficient C)	SHIFT C $\square$	1.495939412 -	
	(The value of $\hat{y}$ when $x_i=16$ )	16 SHIFT $\hat{y}$	6.716296661 <sup>-03</sup>	
	(The value of $\hat{x}$ when $y_i=20$ )	20 SHIFT $\hat{x}$	-13.38291065	
	(The value of $\hat{x}$ when $y_i=20$ )	SHIFT $\hat{x}$	47.14556729	
				175.5872106

Notice when input data:

- Pressing  $\square$   $\square$  can input the same data twice.
- Using  $\square$   $\square$  you can input the same data time after time. For example, if you want to input 20 and 30 five times, you can press 20  $\square$  30  $\square$  5  $\square$ .
- The above result can be required in arbitrary order not necessarily in the above order.
- If you need to delete the just inputting data, you can press  $\square$   $\square$ .

### 7. Degree, minute, and second calculation

- You can use degree(hour), minute and second to go along calculation, and you can also perform sexagesimal system calculation between minute and second, also can transfer between sexagesimal system and decimal system.

	Arithmetic formula	Key-press	Result vision
Example1	Transfer the decimal number 2.258 to sexagesimal system	2.258 $\square$ SHIFT $\square$ $\square$	2.258 2° 15' 28.8"
Example2	Perform the calculation 12° 34' 56" x 3.45	12 $\square$ 34 $\square$ 56 $\square$ $\square$ 3.45 $\square$	43° 24' 31.2"

### 3. The technological instruction relevant to the calculation

#### When come up against problems

If the result is different from the prospective result, or there appears errors, please carry out the following steps:

1. Press  $\square$  1 (COMP) state
2. Press  $\square$   $\square$  1 (DEG) state
3. Press  $\square$   $\square$   $\square$  3 1 (NORM 1 state)
4. Check the using formula to make sure whether it is right.
5. Enter the right state, calculate again.

If the above operations cannot solve the problem yet, please press the reset key RESET, and all the data in the calculator will be deleted.

**Error information**

After the error information appears, the calculator stop working, then press the key **AC** to clear the error, or press **◀ ▶** to show the formula and correct the mistakes.

**Ma ERROR**

The result is over the calculation range of the calculator.

Use a numerical value which is over the input range to go along the functional calculation.

Trying for a unreasonable operation (for example, divide zero, act.)

**Stk ERROR**

Over the capacity range of the stack memory or the operational son stack memory.

**Syn ERROR**

Go along the unreasonable mathematical operation.

**The operation priority**

1. Coordinates transform: Pol (x, y), Rec(r,θ)

2. A type function:  $x^2$ ,  $x^3$ ,  $x^{-1}$ ,  $x!$ ,  $^{\circ}$ ,  $^{\circ}$

You should first input the numerical value and then press the function key in this functional calculation.

3. Power and root  $x^y$ ,  $\sqrt[x]{y}$

4.  $a \frac{b}{c}$

5. Multiplication without multiplicative sign before  $\pi$ , memory's name, variable's name:  $2\pi$ ,  $5A$ ,  $\pi A$  act.

6. B type function:  $\sqrt{\quad}$ ,  $\sqrt[3]{\quad}$ ,  $\log$ ,  $\ln$ ,  $e^x$ ,  $10^x$ ,  $\sin$ ,  $\cos$ ,  $\tan$ ,  $\sin^{-1}$ ,  $\cos^{-1}$ ,  $\tan^{-1}$ ,  $\sinh$ ,  $\cosh$ ,  $\tanh$ ,  $\sinh^{-1}$ ,  $\cosh^{-1}$ ,  $\tanh^{-1}$ , (-)You should first press the function key and then input the numerical value in this functional calculation.

7. Multiplication without multiplicative sign before the B type function.  $2\sqrt{3}$ ,  $A\log 2$  act.

8. Permutation and combination:  $nPr$ ,  $nCr$

9.  $\times$ ,  $\div$

10.  $+$ ,  $-$

• The calculation with the same PRI according to the right to left order to go along.

For example:  $e^x \ln \sqrt{120} \rightarrow e^x (\ln \sqrt{120})$

Other calculation is according to the left to right order.

• The calculation in the bracket will be first carried out.

**Stack memory**

The internal operation number stack memory of the calculator has 10 operation levels, and the dictation stack memory has 24 operation levels. When the calculation is too complex and is over the capacity range of the stack memory, the stack memory error information (Stk ERROR) will appear.

**Turnoff automatically function**

Without any operation for 6 minutes, the calculator will turn off by itself, and press AC/ON to renew power supply.

**Input range**

Internal digits: 12 digits

Precision: Take  $\pm 1$  of the tenth number's precision as standard.



Function	Input range	
sinx/cosx	DEG	$0 \leq  x  \leq 4.499999999 \times 10^{10}$
	RAD	$0 \leq  x  \leq 785398163.3$
	GRAD	$0 \leq  x  \leq 4.999999999 \times 10^{10}$
tanx	DEG	The same as sinx other than when $ x  = (2n-1) \times 90$
	RAD	The same as sinx other than when $ x  = (2n-1) \times \pi/2$
	GRAD	The same as sinx other than when $ x  = (2n-1) \times 100$
$\text{Sin}^{-1}x$	$0 \leq  x  \leq 1$	
$\text{cos}^{-1}x$		
$\text{Tan}^{-1}x$	$0 \leq  x  \leq 9.999999999 \times 10^{99}$	
Sinhx	$0 \leq  x  \leq 230.2585092$	
coshx		
tanhx	$0 \leq  x  \leq 9.999999999 \times 10^{99}$	
$\sinh^{-1}x$	$0 \leq  x  \leq 4.999999999 \times 10^{99}$	
$\cosh^{-1}x$	$1 \leq  x  \leq 4.999999999 \times 10^{99}$	
$\tanh^{-1}x$	$0 \leq  x  \leq 9.999999999 \times 10^{-1}$	
Logx/lnx	$0 < x \leq 9.999999999 \times 10^{99}$	
$10^x$	$-9.999999999 \times 10^{99} \leq x \leq 99.99999999$	
$e^x$	$-9.999999999 \times 10^{99} \leq x \leq 230.2585092$	
$\sqrt{x}$	$0 \leq x < 1 \times 10^{100}$	
$\sqrt[3]{x}$	$ x  < 1 \times 10^{100}$	
$x^2$	$ x  < 1 \times 10^{50}$	
1/x	$ x  < 1 \times 10^{100}; x \neq 0$	
x!	$0 \leq x \leq 69$ (x is an integer)	
nPr	$0 \leq n < 1 \times 10^{10}, 0 \leq r \leq n$ (n,r are integers) $1 \leq \{n!/(n-r)!\} < 1 \times 10^{100}$	
nCr	$0 \leq n < 1 \times 10^{10}, 0 \leq r \leq n$ (n,r are integers) $1 \leq \{n!/\{r!(n-r)!\}\} < 1 \times 10^{100}$	
Pol(x, y)	$ x ,  y  \leq 9.999999999 \times 10^{49}$ $(x^2 + y^2) \leq 9.999999999 \times 10^{99}$	
Rec(r, $\theta$ )	$0 \leq r \leq 9.999999999 \times 10^{99}$ $\theta$ : the same as sinx	
° , ° , °	$ a ,  b ,  c  < 1 \times 10^{100}$	
	Decimal system $\leftrightarrow$ sexagesimal system $0^\circ 0' 0'' \leq x \leq 999999^\circ 59'$	
$x^y$	$x > 0$ : $-1 \times 10^{100} < y \log x < 100$ $x = 0$ : $y > 0$ $x < 0$ : $y = n, \frac{1}{2n+1}$ (n is a integer) At the same time $-1 \times 10^{100} < y \log  x  < 100$	

(To be continued)

(Continued)

Function	Input range
$\sqrt[x]{y}$	$y > 0: x \neq 0, -1 \times 10^{100} < 1/x \log y < 100$ $y = 0: x > 0$ $Y < 0: x = 2n + 1, \frac{1}{n}$ (n is a integer; $n \neq 0$ ) At the same time $-1 \times 10^{100} < 1/x \log  y  < 100$
$a \frac{b}{c}$	The total digits of the integer, numerator and denominator is less than 10 digits (including semicolon)
SD(REG)	$ x  < 1 \times 10^{50},  y  < 1 \times 10^{50}, n < 1 \times 10^{100}$ $x\sigma_n, y\sigma_n, \bar{x}, \bar{y} : n \neq 0$ $x\sigma_{n-1}, y\sigma_{n-1}, A, B, r: n \neq 0, 1$

The precision of a single operation is to the mantissa's last effective number's  $\pm 1$ . When you operate continuously (including some internal continuous calculation, such as  $X^y, \sqrt[x]{x}, x!, \sqrt[3]{x}, nPr, nCr$ ), the calculation error is accumulated. In addition, it is likely to enlarge the error about the odd dot or inflexion of the function.

Calculation range:  $P \pm 10^{-99} \sim \pm 9.999999999 \times 10^{99}$ , if the absolute value of the input or the last or the midterm value is less than  $10^{-99}$ , this value is regarded as zero in the calculating and the display.

#### 4. LCD PLACEMENT DIAGRAM

LCD display screen

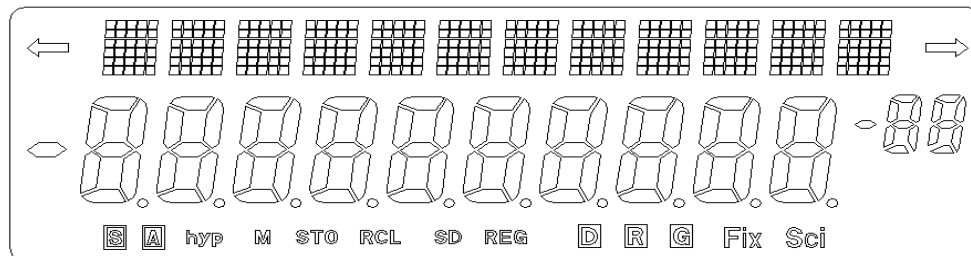

COMMON connection line

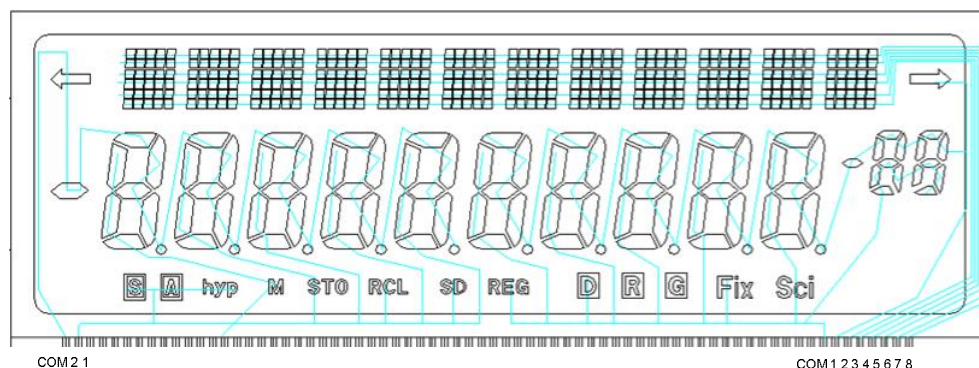



SEGMENT connection line

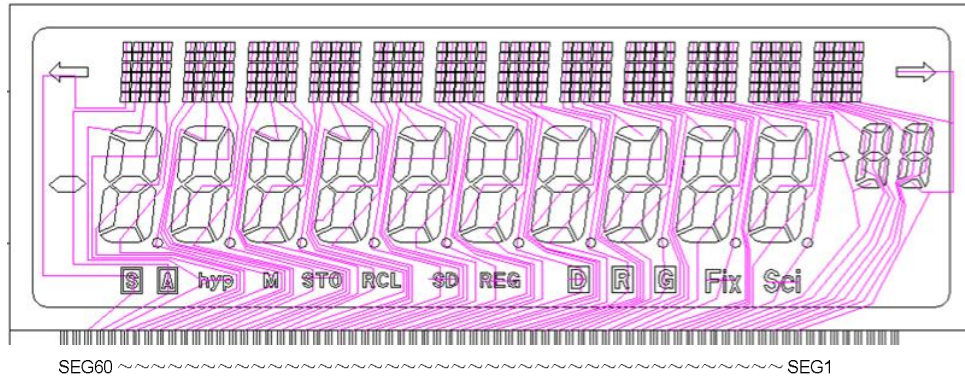

TYPICAL APPLICATION CIRCUIT DIAGRAM

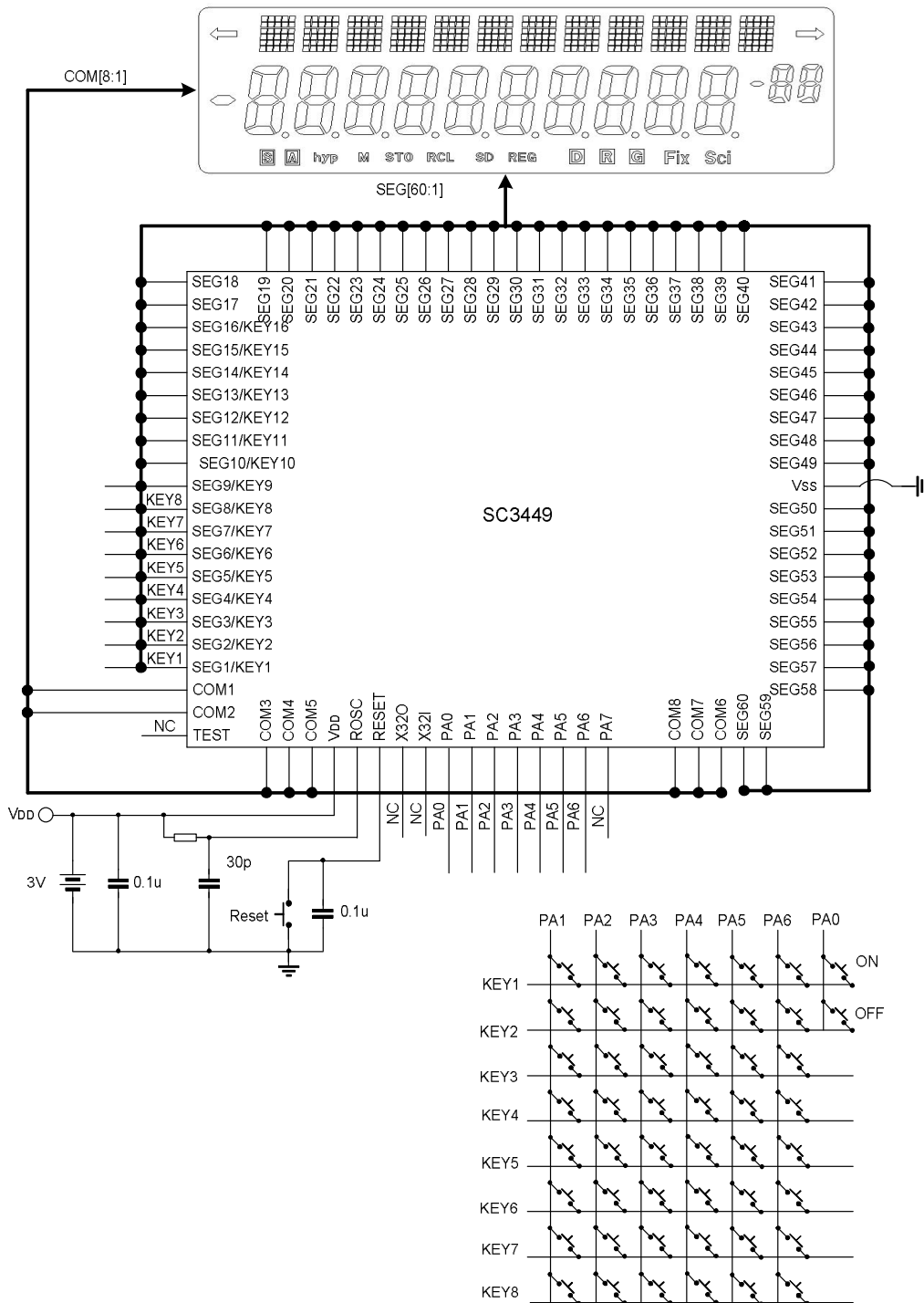

The key-press definition is to see the key-press matrix section.

**KEYBOARD MATRIX AND DEFINITION**

Key-press input matrix

Key	Pa1	Pa2	Pa3	Pa4	Pa5	Pa6	Pa0
Key1	x! x <sup>-1</sup>	nPr nCr	Rec( Pol(	$\sqrt[3]{\quad}$	x <sup>3</sup>	$\sqrt[x]{\quad}$ x <sup>y</sup>	Mcl Scl AC / ON
Key2	← Eng	d/c a_b/c	$\sqrt{\quad}$	x <sup>2</sup>	10 <sup>x</sup> Log	e <sup>x</sup> Ln	OFF
Key3	A (-)	← B ° , , ,	C Hyp	Sin <sup>-1</sup> D Sin	Cos <sup>-1</sup> E Cos	Tan <sup>-1</sup> F Tan	
Key4	STO	RCL	r (	X )	; Y ,	M- M M+ DT CL	
Key5	A 7	B 8	C 9	INS DEL	MODE	SHIFT	
Key6	y 4	yσ <sub>n</sub> 5	yσ <sub>n-1</sub> 6	x	÷	ALPHA	
Key7	x 1	xσ <sub>n</sub> 2	xσ <sub>n-1</sub> 3	$\hat{x}$ +	$\hat{y}$ -	←	
S8	Rnd 0	Ran# .	π EXP	DRG ANS	% =	→	

**CHIP TOPOGRAPHY**

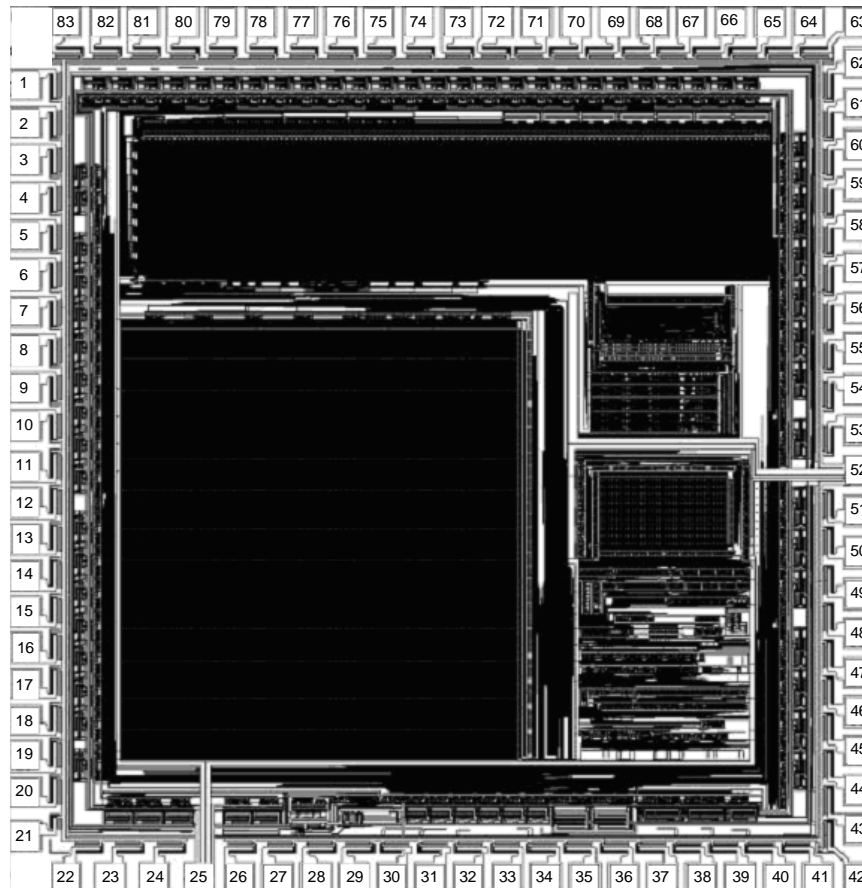

CMOS chip dimension: 3.33X3.44(mm<sup>2</sup>)

Note: The substrate is connected to GND.

**THE COORDINATE OF THE KEY**

Pad No.	Symbol	X	Y	Pad No.	Symbol	X	Y
1	SEG18	1544.2	-1364.9	43	SEG58	-1542.4	1417.3
2	SEG17	1544.2	-1223.9	44	SEG57	-1542.4	1271.0
3	SEG16	1544.2	-1082.0	45	SEG56	-1542.4	1124.4
4	SEG15	1544.2	-940.7	46	SEG55	-1542.4	978.2
5	SEG14	1544.2	-799.3	47	SEG54	-1542.4	832.0
6	SEG13	1544.2	-656.5	48	SEG53	-1542.4	685.3
7	SEG12	1544.2	-515.0	49	SEG52	-1542.4	539.2
8	SEG11	1544.2	-373.5	50	SEG51	-1542.4	384.0
9	SEG10	1544.2	-232.5	51	SEG50	-1542.4	228.6

(To be continued)

(Continued)

Pad No.	Symbol	X	Y	Pad No.	Symbol	X	Y
10	SEG9	1544.2	-90.8	52	Vss	-1542.4	78.7
11	SEG8	1544.2	63.4	53	SEG49	-1542.4	-74.0
12	SEG7	1544.2	200.0	54	SEG48	-1542.4	-226.3
13	SEG6	1544.2	335.0	55	SEG47	-1542.4	-379.0
14	SEG5	1544.2	470.0	56	SEG46	-1542.4	-531.6
15	SEG4	1544.2	604.8	57	SEG45	-1542.4	-684.0
16	SEG3	1544.2	739.6	58	SEG44	-1542.4	-836.4
17	SEG2	1544.2	874.6	59	SEG43	-1542.4	-988.8
18	SEG1	1544.2	1009.4	60	SEG42	-1542.4	-1141.4
19	COM1	1544.2	1144.2	61	SEG41	-1542.4	-1293.0
20	COM2	1544.2	1279.0	62	SEG40	-1542.4	-1445.7
21	TEST	1544.2	1442.0	63	SEG39	-1542.4	-1596.6
22	COM3	1394.2	1598.4	64	SEG38	-1357.6	-1596.6
23	COM4	1229.4	1598.4	65	SEG37	-1213.6	-1596.6
24	COM5	1066.8	1598.4	66	SEG36	-1069.5	-1596.6
25	VDD	900.6	1598.4	67	SEG35	-925.6	-1596.6
26	ROSC	750.7	1598.4	68	SEG34	-781.4	-1596.6
27	RESET	609.7	1598.4	69	SEG33	-637.7	-1596.6
28	X32O	468.2	1598.4	70	SEG32	-493.7	-1596.6
29	X32I	328.2	1598.4	71	SEG31	-349.5	-1596.6
30	PA0	187.2	1598.4	72	SEG30	-205.3	-1596.6
31	PA1	43.9	1598.4	73	SEG29	-55.1	-1596.6
32	PA2	-99.4	1598.4	74	SEG28	89.4	-1596.6
33	PA3	-242.3	1598.4	75	SEG27	233.7	-1596.6
34	PA4	-385.6	1598.4	76	SEG26	378.0	-1596.6
35	PA5	-529.0	1598.4	77	SEG25	522.6	-1596.6
36	PA6	-672.6	1598.4	78	SEG24	671.8	-1596.6
37	PA7	-815.6	1598.4	79	SEG23	819.0	-1596.6
38	COM8	-959.0	1598.4	80	SEG22	962.7	-1596.6
39	COM7	-1103.5	1598.4	81	SEG21	1106.7	-1596.6
40	COM6	-1248.8	1598.4	82	SEG20	1250.4	-1596.6
41	SEG60	-1392.0	1598.4	83	SEG19	1394.2	-1596.6
42	SEG59	-1542.4	1598.4				

Note: the origin of the coordinate is in the middle of the chip.



#### **HANDLING MOS DEVICES:**

Electrostatic charges can exist in many things. All of our MOS devices are internally protected against electrostatic discharge but they can be damaged if the following precautions are not taken:

- Persons at a work bench should be earthed via a wrist strap.
- Equipment cases should be earthed.
- All tools used during assembly, including soldering tools and solder baths, must be earthed.
- MOS devices should be packed for dispatch in antistatic/conductive containers.

Note: Silan reserves the right to make changes without notice in this specification for the improvement of the design and performance.  
Silan will supply the best possible product for customers.

ATTACH

Revision History

Data	REV	Description	Page
2005.08.16	1.0	Original	
2007.11.19	1.1	Modify the "Fraction calculation "	