

# 3 to 5cells Li-ion/Li-polymer battery protection IC

## Monolithic IC MM3474 Series

### Outline

MM3474 Series is an overcharge, overdischarge and overcurrent protection IC for a Li-ion/Li-polymer rechargeable battery, which detects overcharge, overdischarge, discharging overcurrent and short of a single-cell Li-ion/Li-polymer battery.

This supports 3 to 5 cells connected in series, and switches over to the desired no. of cells by sending High/Low signal to SEL terminal.

This also provides the control terminals of output over discharge detection (SDC) and output over charge detection (SOC), which allows configuring an application with fewer external parts for 8 to 10 cells connected in series.

### Features

(Unless otherwise specified, Topr=+25°C)

1. Range and accuracy of detection/release voltage

● Overcharge detection voltage	3.6V to 4.5V, 5mV steps	Accuracy±25mV (Topr=-5 to +60°C)
● Overcharge release voltage	3.4V to 4.5V, 50mV steps	Accuracy±50mV
● Overdischarge detection voltage	2.0V to 3.0V, 50mV steps	Accuracy±80mV
● Overdischarge release voltage	2.0V to 3.4V, 50mV steps	Accuracy±100mV
● Overcurrent detect voltage	50mV to 300mV, 5mV steps	Accuracy±15mV
● Short detection voltage	0.2V to 1.0V, 50mV steps	Accuracy±100mV

2. Each detection delay time set by the external capacitor

3. The setting for three cell , for four cell , and for five cell protection can be set with the SEL1 pin and the SEL2 pin.

4. Low current consumption

● Consumption current1(Vdd) , Vcell=4.4V	Typ. 10.0µA, Max. 20.0µA
● Consumption current1(V5) , Vcell=4.4V	Typ. 4.0µA, Max. 8.0µA
● Consumption current3(Vdd) , Vcell=1.8V	Typ. 1.5µA, Max. 3.0µA
● Consumption current3(V5) , Vcell=1.8V	Typ. 1.5µA, Max. 3.0µA

5. Absolute maximum ratings

● VDD pin	VSS2-0.3V ~ +30V
● V5 pin	V4-0.3V ~ VDD+0.3V
● Between the input terminals of voltage of battery	-0.3V ~ +10V
● V- pin , CS pin	VDD-30V ~ VDD+0.3V
● OV pin , DCHG pin	VSS2-0.3V ~ VDD+0.3V
● SEL pin	VSS2-0.3V ~ VDD+0.3V
● SDC pin , SOC pin	VSS2-0.3V ~ VDD+0.3V
● Storage temperature	-55 to +125°C
● Operation temperature	-40 to +85°C

### Pin Assignment

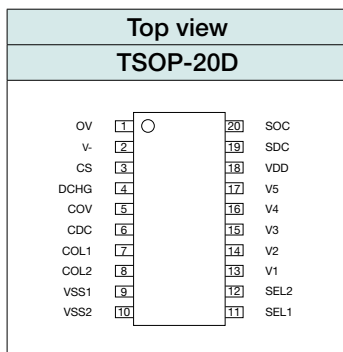

**Selection Guide** (2000pcs/Reel)

Product name	Detection / Release voltage						Detection / Release voltage						Optional function
	Overcharge detection voltage	Overcharge release voltage	Overdischarge detection voltage	Overdischarge release voltage	Overcurrent detection voltage	Short detection voltage	Overcharge detection dead time	Overcharge release dead time	Overdischarge detection dead time	Overdischarge release dead time	Overcurrent detection dead time	Overcurrent release dead time	Overdischarge release
	V <sub>CELLU</sub>	V <sub>CELLO</sub>	V <sub>CELLS</sub>	V <sub>CELLD</sub>	V <sub>OC</sub>	V <sub>SHORT</sub>	tov1	toV2	tdc1	tdc2	toc1	toc2	*1
	V	V	V	V	mV	V	sec	msec	sec	msec	msec	msec	
MM3474C01VBE	4.250	4.150	2.800	3.000	250	1.00	1.0	0.1	1.0	Max.5	10.0	10.0	Non Latch
MM3474C02VBE	4.250	4.150	2.400	2.600	250	1.00	1.0	0.1	1.0	Max.5	10.0	10.0	Non Latch
MM3474C03VBE	4.250	4.150	2.800	3.000	250	0.80	1.0	0.1	1.0	Max.5	10.0	10.0	Non Latch
MM3474D01VBE	3.850	3.650	2.300	2.500	150	1.00	1.0	0.1	1.0	Max.5	10.0	10.0	Non Latch
MM3474D03VBE	3.800	3.600	2.000	2.500	150	0.60	1.0	0.1	1.0	Max.5	10.0	10.0	Non Latch
MM3474E01VBE	4.250	4.150	2.800	3.000	150	1.00	1.0	0.1	1.0	Max.5	10.0	10.0	Non Latch
MM3474E02VBE	4.200	4.100	2.800	3.000	150	1.00	1.0	0.1	1.0	Max.5	10.0	10.0	Non Latch
MM3474E03VBE	4.175	4.100	2.800	3.000	150	0.50	1.0	0.1	1.0	Max.5	10.0	10.0	Non Latch
MM3474E04VBE	4.250	4.150	2.800	3.000	100	0.50	1.0	0.1	1.0	Max.5	10.0	10.0	Non Latch
MM3474E05VBE	4.250	4.150	2.800	3.000	50	0.40	1.0	0.1	1.0	Max.5	10.0	10.0	Non Latch
MM3474F01VBE	4.250	4.150	2.500	3.000	150	1.00	1.0	0.1	1.0	Max.5	10.0	10.0	Non Latch
MM3474F02VBE	4.200	4.100	2.500	3.000	100	1.00	1.0	0.1	1.0	Max.5	10.0	10.0	Non Latch
MM3474F03VBE	4.250	4.150	2.500	3.000	100	0.30	1.0	0.1	1.0	Max.5	10.0	10.0	Latch
MM3474F04VBE	4.250	4.210	2.500	3.000	100	0.80	1.0	0.1	1.0	Max.5	10.0	10.0	Non Latch
MM3474F05VBE	4.250	4.150	2.500	3.000	100	0.25	1.0	0.1	1.0	Max.5	10.0	10.0	Non Latch
MM3474G01VBE	4.200	4.100	2.750	3.000	100	1.00	1.0	0.1	1.0	Max.5	10.0	10.0	Non Latch
MM3474G02VBE	4.250	4.150	2.750	3.000	100	1.00	1.0	0.1	1.0	Max.5	10.0	10.0	Non Latch
MM3474G03VBE	4.200	4.100	2.750	3.000	100	0.40	1.0	0.1	1.0	Max.5	10.0	10.0	Non Latch
MM3474G05VBE	4.250	4.150	2.750	3.000	100	0.40	1.0	0.1	1.0	Max.5	10.0	10.0	Non Latch
MM3474J01VBE	4.250	4.100	2.800	3.000	50	1.00	1.0	0.1	1.0	Max.5	10.0	10.0	Non Latch
MM3474K01VBE	4.250	4.100	3.000	3.300	100	0.30	1.0	0.1	1.0	Max.5	10.0	10.0	Non Latch
MM3474L01VBE	3.650	3.500	2.000	2.700	100	0.30	1.0	0.1	1.0	Max.5	10.0	10.0	Non Latch
MM3474L02VBE	3.750	3.550	2.200	2.700	100	0.40	1.0	0.1	1.0	Max.5	10.0	10.0	Non Latch
MM3474M01VBE	4.350	4.150	2.300	3.000	150	0.50	1.0	0.1	1.0	Max.5	10.0	10.0	Non Latch
MM3474N01VBE	3.900	3.600	2.000	3.000	100	0.20	1.0	0.1	1.0	Max.5	10.0	10.0	Latch

\*1 Non Latch : voltage release  
 Latch : voltage release + load remove

Please inquire to us, if you request a rank other than the above.

Application Circuit

• 5 cells protection circuit

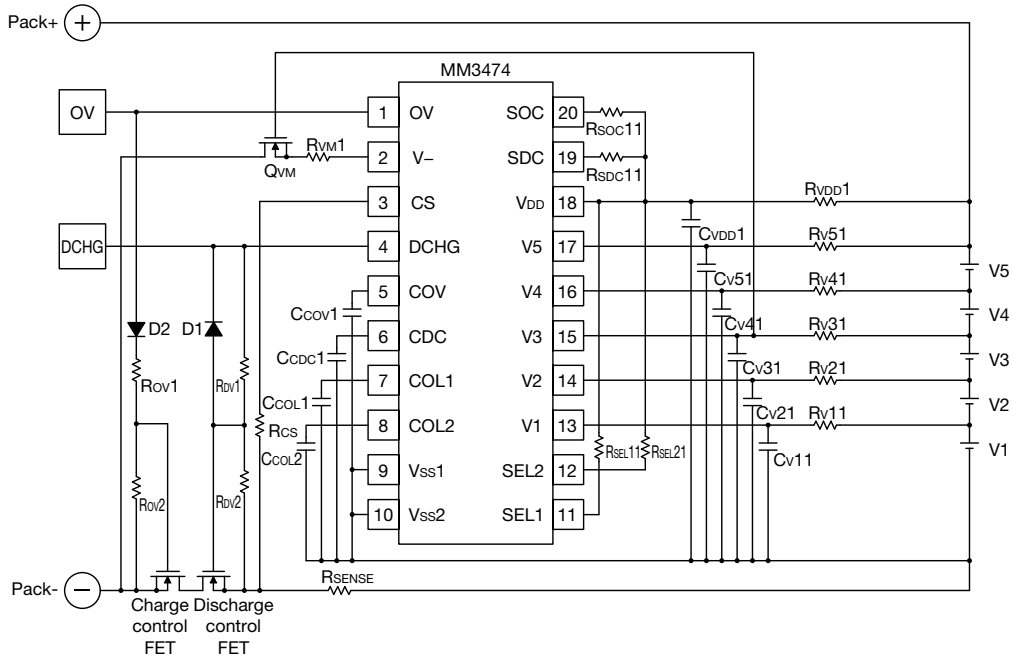

SEL1	SEL2	mode
H	H	5Cell in series
H	L	4Cell in series (Connect V1 and VSS terminal)
L	H	3Cell in series (Connect V2,V1 and VSS terminal)

\* It becomes a static test mode in SEL1=SEL2=Low.

Application Circuit

• 10 cells protection circuit

