

POWER MANAGEMENT

Features

- Input voltage range — 2.7V to 5.5V
- Dual buck converters with independent control
- High efficiency — over 90% peak
- Up to 800mA Load
- Programmable output voltages per channel — 8
- Fixed-frequency operation — 1MHz
- Optional SYNC clock input
- Optional power-save under light-load conditions
- Shutdown current <math>< 1\mu\text{A}</math>
- Soft-start to limit in-rush current
- 4mm x 4mm MLPQ package

Applications

- Mobile phones
- Cordless phones
- MP3 players
- Digital cameras
- PDAs
- Single Li-Ion cell or (3) NiMH/NiCd cell devices
- Digital multimedia broadcast (DMB) devices
- Portable gaming systems

Description

The SC198A is a dual high-efficiency synchronous buck converter designed for use in low power applications. Each converter is capable of supplying up to 800mA of average current at one of eight programmable output voltages used as microprocessor supply voltages.

The SC198A uses a single control logic block for the two converters, but their controls can be set independently. The device uses a flexible clocking method allowing the user to set the fixed internal 1MHz oscillator or synchronize the clock to an external source. The device also has an optional power-save mode that optimizes efficiency for light loads.

The SC198A provides output voltage flexibility while conserving board space by using control pins to select the output voltage. This eliminates at least four parts from the traditional dual buck converter bill of materials.

Typical Application Circuit

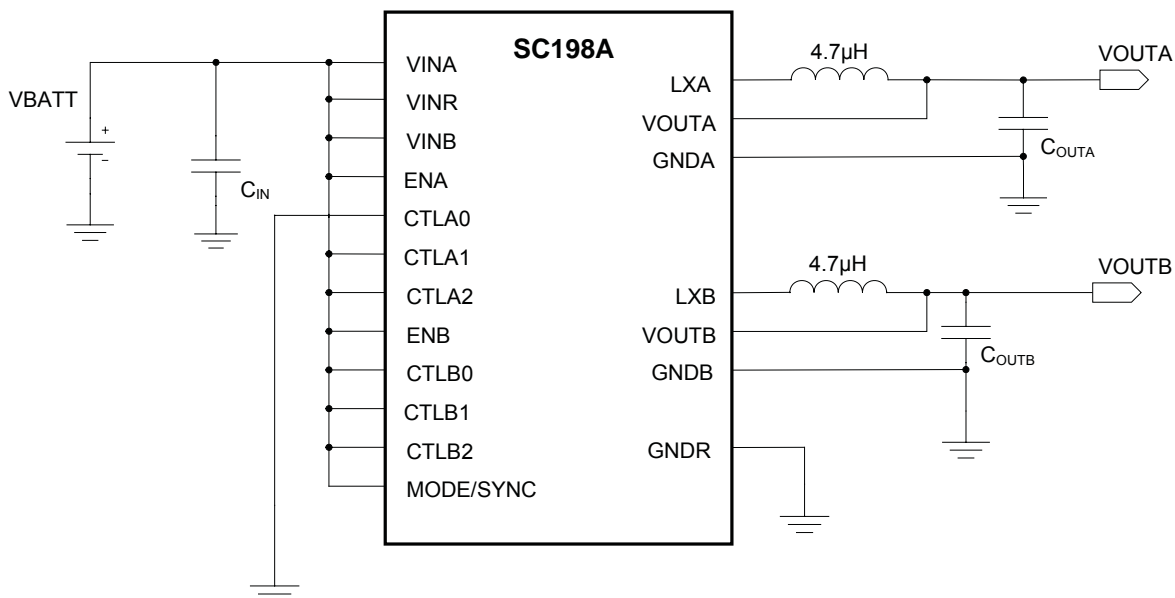

Pin Configuration

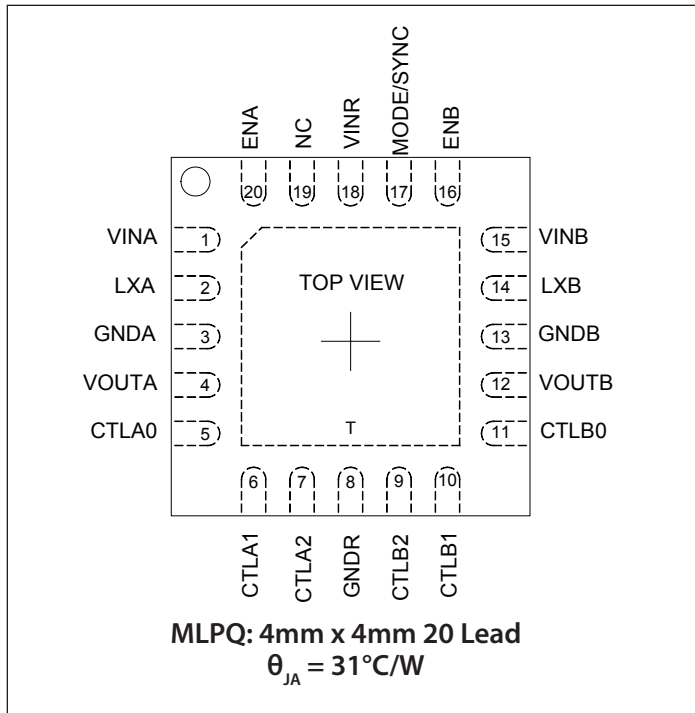

Ordering Information

Device	Package
SC198AMLTRT ^{(1) (2)}	MLPQ-20
SC198AEVB	Evaluation Board

Notes:

- (1) Available in tape and reel only. A reel contains 3,000 devices.
- (2) Lead-free package only. Device is WEEE and RoHS compliant.

Marking Information

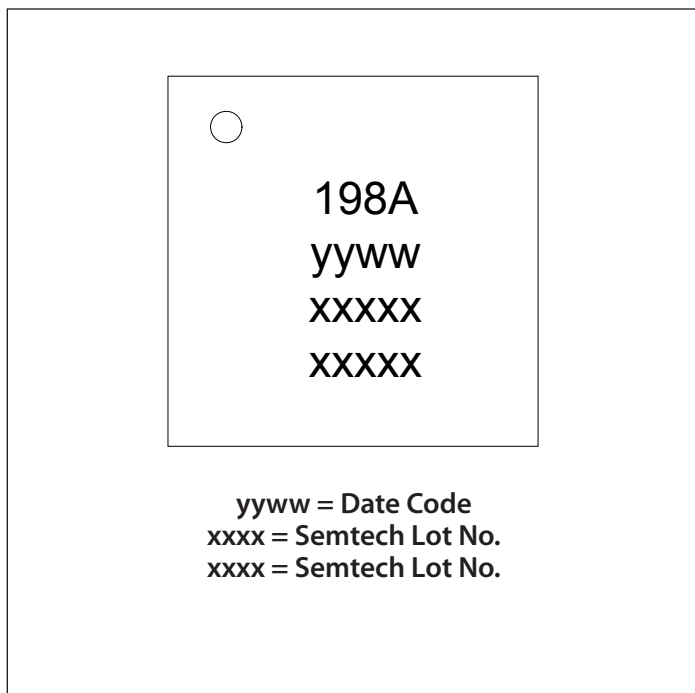

Absolute Maximum Ratings

V_{IN} (V)	-0.3 to +7
V_{OUT} (V)	-0.3 to $V_{IN} + 0.3$
V_{LXA} and V_{LXB} (V)	-1 to $V_{IN} + 1$
Pin Voltage - All Other Pins (V)	-0.3 to ($V_{IN} + 0.3$)
Output Short Circuit to GND Duration	Continuous
LXA and LXB Currents (A)	1.2
ESD Protection Level ⁽¹⁾ (kV)	2

Recommended Operating Conditions

Ambient Temperature Range (°C)	-40 to +85
V_{IN} (V)	2.7 to 5.5

Thermal Information

Thermal Resistance, Junction to Ambient ⁽²⁾ (°C/W)	31
Maximum Junction Temperature (°C)	+150
Storage Temperature Range (°C)	-65 to +150
Peak IR Reflow Temperature (10s to 30s) (°C)	+260

Exceeding the above specifications may result in permanent damage to the device or device malfunction. Operation outside of the parameters specified in the Electrical Characteristics section is not recommended.

NOTES:

- (1) Tested according to JEDEC standard JESD22-A114-B.
- (2) Calculated from package in still air, mounted to 3 x 4.5 (in), 4 layer FR4 PCB with thermal vias under the exposed pad per JESD51 standards.

Electrical Characteristics

Unless otherwise noted: $V_{IN} = 3.6V$, $V_{MODE/SYNC} = V_{IN}$, $L = 4.7\mu H$, $C = 10\mu F$, $T_A = -40^\circ C$ to $+85^\circ C$. Typical values are at $T_A = 25^\circ C$ for both outputs.

Parameter	Symbol	Conditions	Min	Typ	Max	Units
Input Voltage Range	V_{IN}	$V_{OUT} = 1.8V$	2.7		5.5	V
		$V_{OUT} = 3.3V$	4.0		5.5	
V_{OUT} Accuracy ⁽¹⁾	ΔV_{OUT}	$I_{OUT} = 10mA$ to $800mA$, $V_{IN} \geq 0.7V + V_{OUT}$	-3		3	%
Line Regulation	ΔV_{LINE}	$V_{IN} = 2.7$ to $5.5V$, $V_{OUT} = 1.8V$, $I_{OUT} = 300mA$			0.2	% / V
		$V_{IN} = 4.0$ to $5.5V$, $V_{OUT} = 3.3V$, $I_{OUT} = 300mA$				
Load Regulation	ΔV_{LOAD}	$I_{OUT} = 10mA$ to $800mA$, $V_{OUT} = 1.8V$			0.0008	% / mA
		$I_{OUT} = 10mA$ to $800mA$, $V_{OUT} = 3.3V$, $V_{IN} = 5.0V$				
Minimum Duty Cycle	DC_{MIN}				18	%
LXA, LXB Current Limit	I_{LIM}		1.2			A
Quiescent Current	I_Q	$I_{OUT} = 0mA$, $SYNC = 0$, $ENA, ENB = V_{IN}$			50	μA
Shutdown Current	I_{SD}	$V_{ENA}, V_{ENB} = 0$, LXA, LXB = Open		0.1	1	μA
LXA and LXB Leakage Current	I_{LXA}, I_{LXB}	$V_{IN} = 5.5V$, $V_{LX} = 0V$, PMOS		0.1	1	μA
		$V_{IN} = 5.5V$, $V_{LX} = V_{IN}$, NMOS	-2	0.1		μA
P-Channel On Resistance	R_{DSP}	$I_{LXA}, I_{LXB} = 100mA$		0.35		Ω

Electrical Characteristics (continued)

Parameter	Symbol	Conditions	Min	Typ	Max	Units
N-Channel On Resistance	R_{DSN}	$I_{LXA}, I_{LXB} = 100\text{mA}$		0.25		Ω
Start-Up Time	t_{START}				5	ms
Oscillator Frequency	f_{OSC}		0.95	1.1	1.25	MHz
SYNC Frequency (upper)	f_{SYNCU}		1.25			MHz
SYNC Frequency (lower)	f_{SYNCL}				0.75	MHz
Thermal Shutdown	T_{HI}			145		$^{\circ}\text{C}$
Thermal Shutdown Hysteresis	T_{HYSR}			10		$^{\circ}\text{C}$
UVLO Threshold	V_{UVL}	Decreasing V_{IN}	2.4	2.5	2.6	V
UVLO Hysteresis	V_{UVLHYS}			50		mV
Logic Input High ⁽²⁾	V_{IH}		1.6			V
Logic Input Low ⁽²⁾	V_{IL}				0.6	V

Notes:

- (1) See Output Voltage Options table in the Application Information section.
- (2) For ENA, ENB, SYNC, CTLA0, CTLA1, CTLA2, CTLB0, CTLB1, CTLB2.

Pin Descriptions

Pin #	Pin Name	Pin Function
1	VINA	Input power supply voltage for converter A
2	LXA	Connection point for the inductor on converter A
3	GNDA	Ground reference to converter A
4	VOUTA	Feedback control input for converter A
5	CTLA0	Voltage select control pin 0 for output A (see Table 1 — Output Voltage Options).
6	CTLA1	Voltage select control pin 1 for output A (see Table 1 — Output Voltage Options).
7	CTLA2	Voltage select control pin 2 for output A (see Table 1 — Output Voltage Options).
8	GNDR	Ground for reference supply
9	CTLB2	Voltage select control pin 2 for output B (see Table 1 — Output Voltage Options).
10	CTLB1	Voltage select control pin 1 for output B (see Table 1 — Output Voltage Options).
11	CTLB0	Voltage select control pin 0 for output B (see Table 1 — Output Voltage Options).
12	VOUTB	Feedback control input for converter B
13	GNDB	Ground reference for converter B
14	LXB	Connection point for the inductor on converter B
15	VINB	Input power supply voltage for converter B
16	ENB	Enable pin for output B
17	MODE/SYNC	Oscillator synchronization input — connect to VIN for forced PWM mode, ground for power-save mode or connect to an external clock for frequency synchronization.
18	VINR	Reference supply input
19	NC	Not connected — Leave open
20	ENA	Enable pin for output A
T	THERMAL PAD	Thermal pad for heatsinking purposes — connect to ground plane using multiple vias — not connected internally

Block Diagram

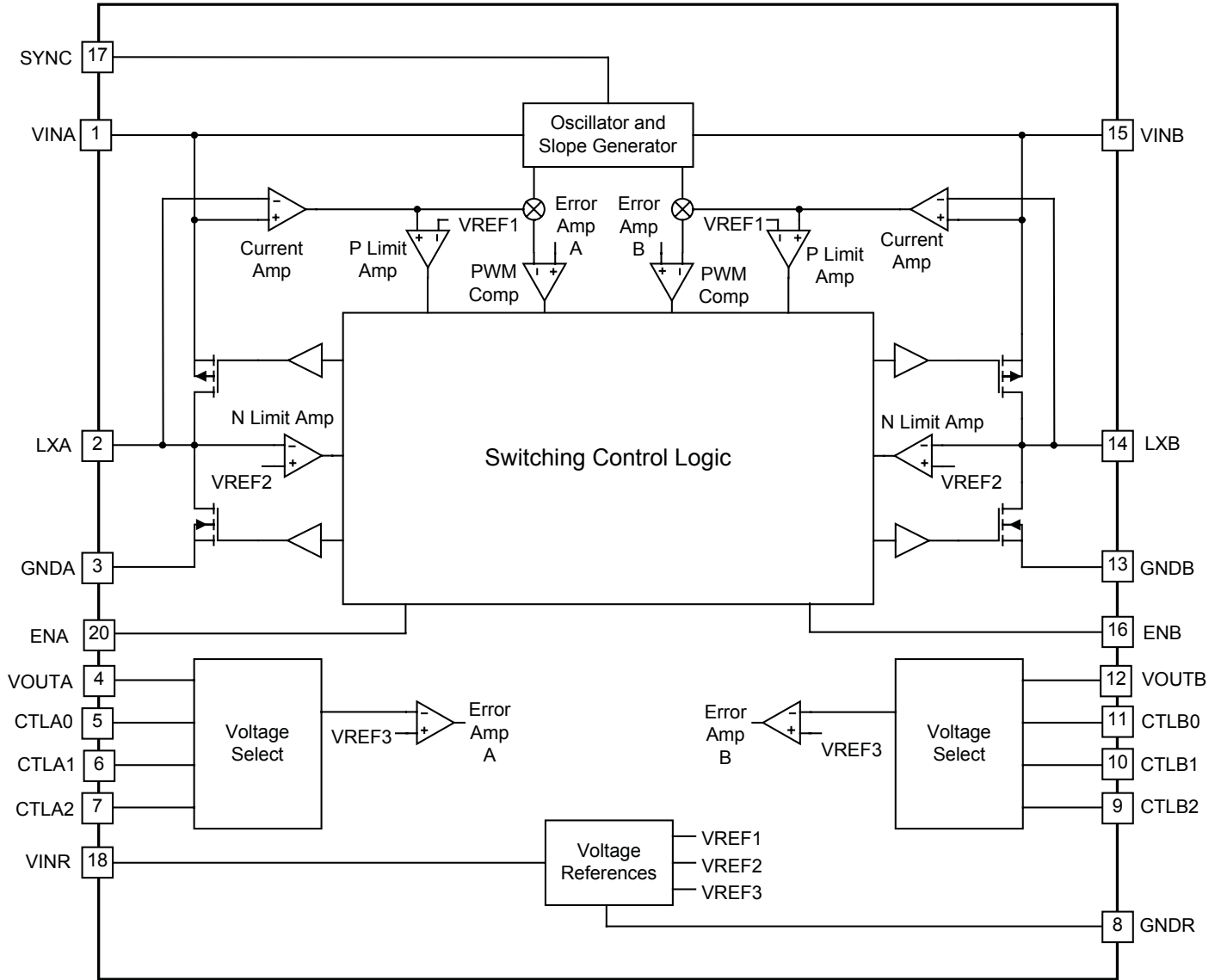

Typical Characteristics

Efficiency vs. Load at $V_{IN} = 2.7V$, Side A

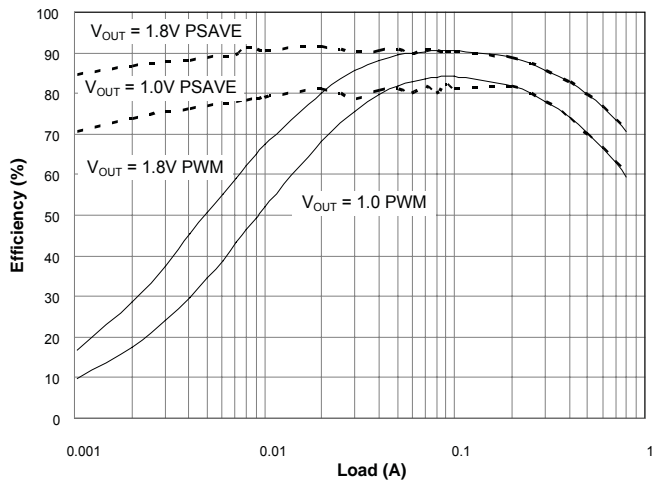

Efficiency vs. Load at $V_{IN} = 3.6V$, Side A

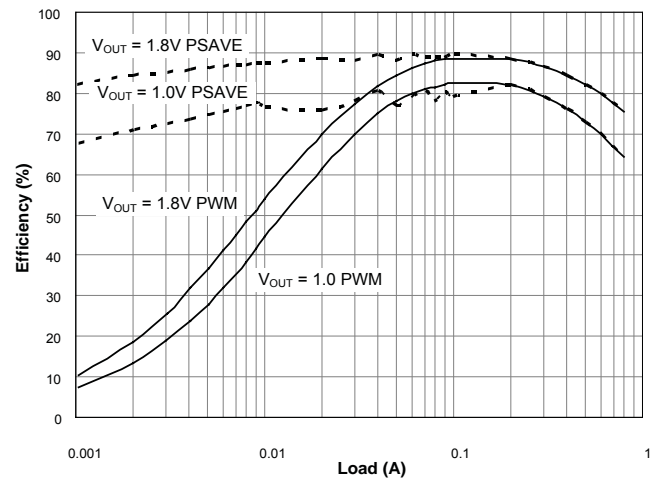

Efficiency vs. Load at $V_{IN} = 5.5V$, Side A

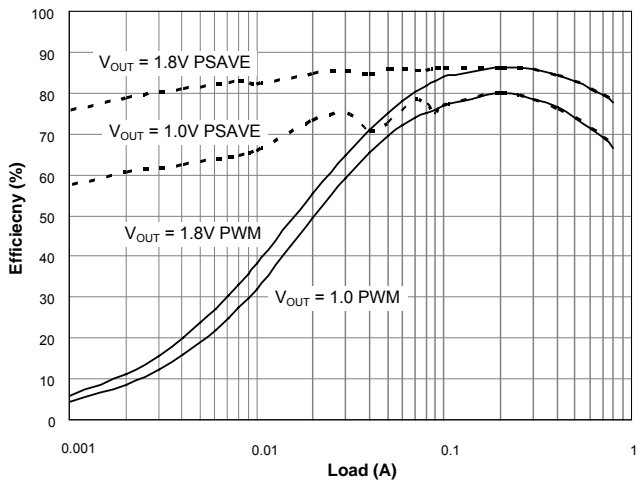

Efficiency vs. Load at $V_{IN} = 5.5V$, Side B

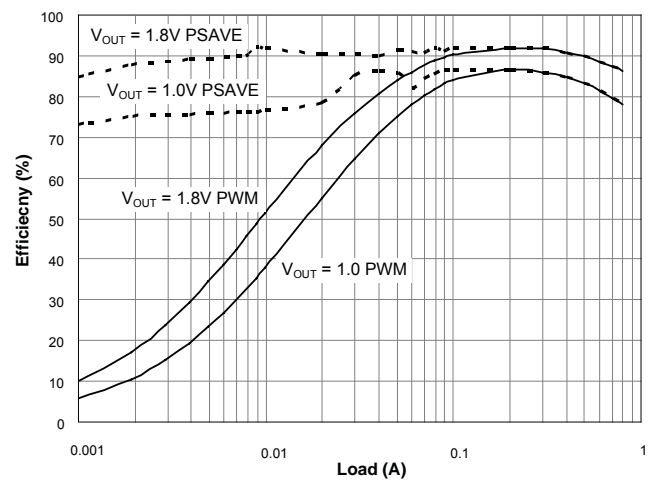

Line Regulation at 300mA

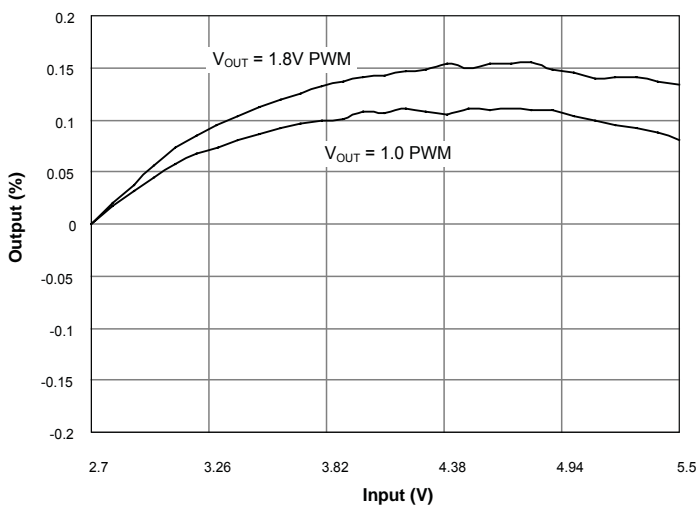

Load Regulation — $V_{OUT} = 1.8V, V_{IN} = 3.6V$

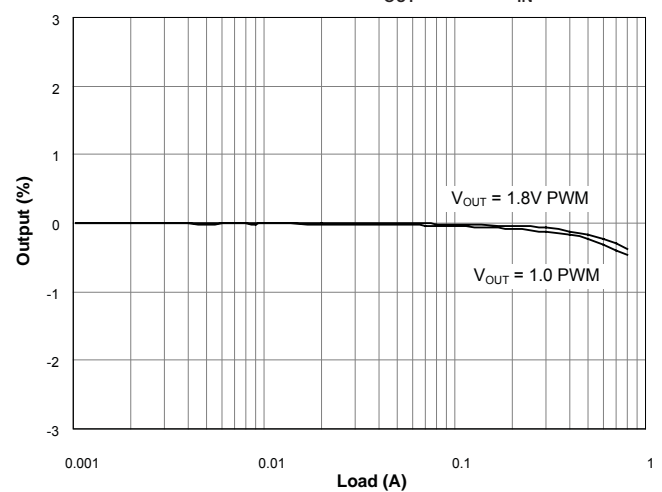

Typical Characteristics (continued)

V_{OUT} vs. V_{IN} — 3.3V Programmed Output

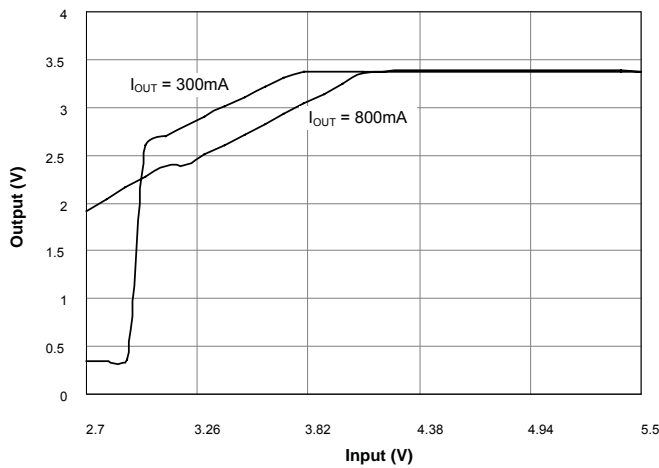

V_{OUT} vs. V_{IN} — 1.8V Programmed Output

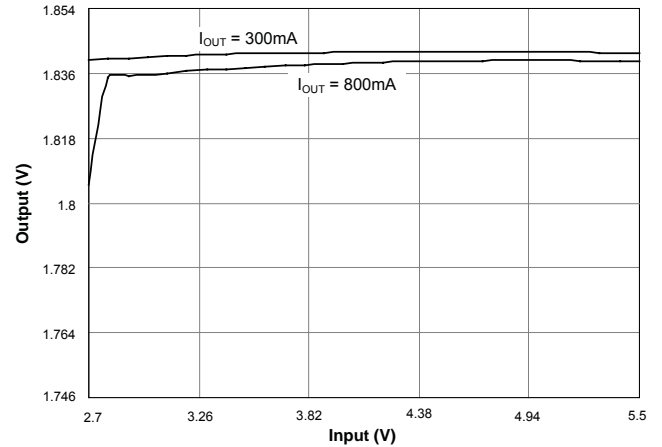

Crosstalk in PSAVE

$V_{IN} = 5.0V, 25^{\circ}C, V_{OUTA} = 1.0V, I_{OUTA} = 80mA, V_{OUTB} = 3.3V, I_{OUTB} = 0mA$

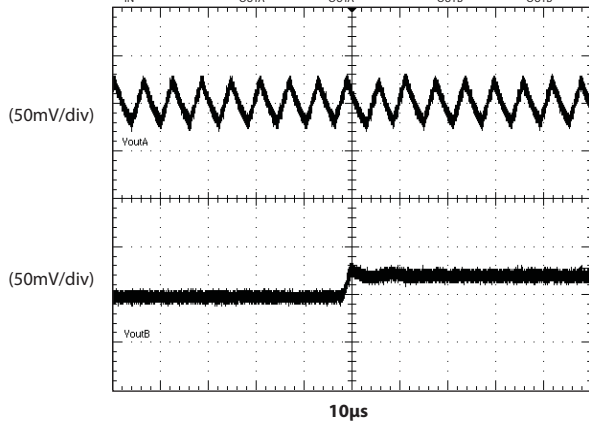

Crosstalk — Side A (PSAVE) Side B (PWM)

$V_{IN} = 5.0V, 25^{\circ}C, V_{OUTA} = 1.0V, I_{OUTA} = 80mA, V_{OUTB} = 3.3V, I_{OUTB} = 800mA$

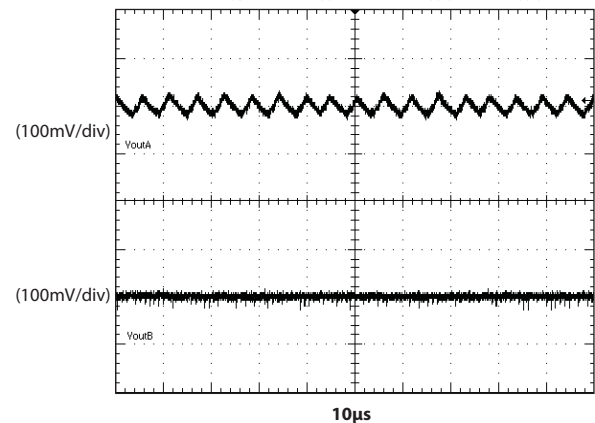

Transient in PSAVE

$V_{OUT} = 1.0V, V_{IN} = 3.6V, 25^{\circ}C, I_{OUT} = 0 \text{ to } 800mA$

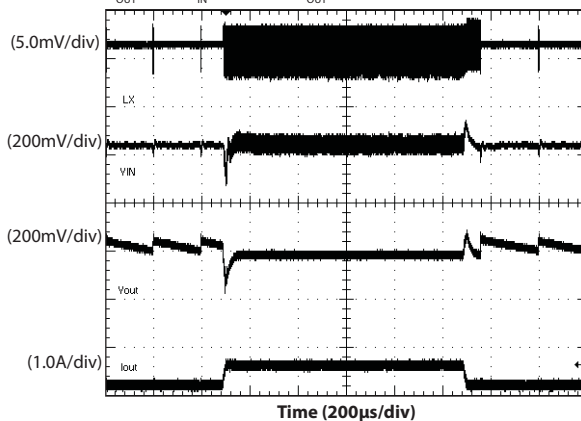

Transient in PWM

$V_{OUT} = 1.8V, V_{IN} = 3.6V, 25^{\circ}C, I_{OUT} = 0 \text{ to } 800mA$

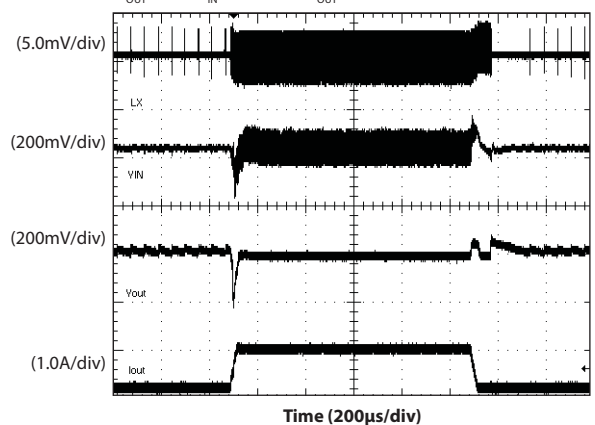

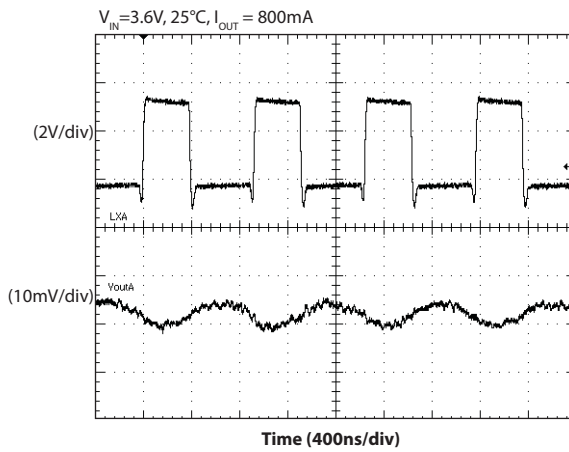
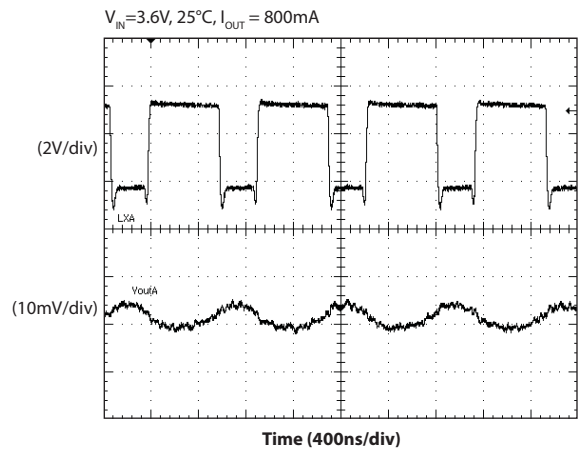
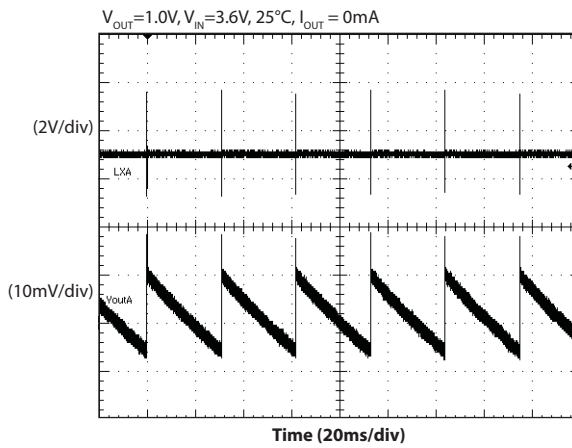
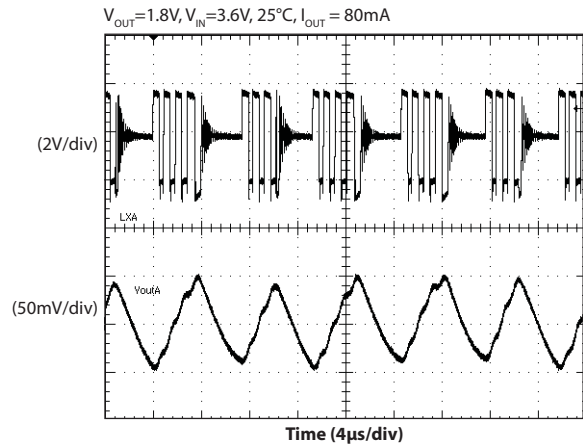
Typical Characteristics (continued)
Switching Waveforms — $V_{OUT}=1.0V$

Switching Waveforms — $V_{OUT}=1.8V$

Switching Waveforms in PSAVE

Switching Waveforms in PSAVE

Application Information

Detailed Description

The SC198A is a dual step-down, pulse-width modulated DC-DC converter with programmable output voltage and power-save mode. This device has a 1MHz internal oscillator that can be used during forced PWM mode or power-save mode (PSAVE).

Operation

During normal operation, the PMOS switch is activated on each rising edge of the internal oscillator. Current feedback for the switching regulator is through the PMOS current path, and it is amplified and summed with the internal slope compensation network. The voltage feedback loop uses an internal feedback divider. The on-time is determined by comparing the summed current feedback and the output of the error amplifier. The period is set by the onboard oscillator or by an external clock attached to the MODE/SYNC pin. When synchronizing to an external frequency, the SC198A operates in PWM mode only. The device has an internal synchronous NMOS rectifier and does not require a Schottky diode on the LX pin. The device is designed to operate as a buck converter in PWM mode with a fixed frequency of 1MHz. At light loads, the part can enter PSAVE mode to maximize efficiency.

Output Filter

The SC198A converter also has internal loop compensation. The internal compensation is designed to work with a specific output filter corner frequency defined by the equation

$$f_c = \frac{1}{2\pi\sqrt{L \times C_{OUT}}}$$

When selecting output filter components, the LC product should not vary over a wide range. The practical lower limit for the inductor value is 4.7µH to ensure system stability. Selection of smaller inductor and capacitor values will shift the corner frequency higher, which may impact stability. The internal compensation is designed to operate with a single-pole output filter where $L = 4.7\mu\text{H}$ and $C_{OUT} = 10\mu\text{F}$.

Programmable Output Voltage

The SC198A has three control pins per output to allow selection of a voltage level from eight predetermined output voltage levels (see Table 1). CAUTION — All CTL pins must be pulled high or low for proper operation (they must not be allowed to float). The output voltage can be selected while the device is enabled and loaded.

Table 1 — Output Voltage Options

Programmable Output Voltage				
CTLA2/B2	CTLA1/B1	CTLA0/B0	Nominal Output Voltage (V)	
			A	B
0	0	0	1.0	1.8
0	0	1	1.1	2.2
0	1	0	1.2	2.5
0	1	1	1.3	2.7
1	0	0	1.4	2.8
1	0	1	1.5	2.9
1	1	0	1.6	3.0
1	1	1	1.8	3.3

Continuous Conduction and Oscillator Synchronization

The SC198A is designed to operate in continuous conduction mode, where it maintains a fixed frequency. When the MODE/SYNC pin is tied high, the part runs under control of the internal oscillator in PWM mode. The part can be synchronized to an external clock by connecting a clock signal to the MODE/SYNC pin. The part synchronizes to the rising edge of the clock.

Power-Save Mode Operation

The SC198A has a power-save mode (PSAVE) which may be selected by tying the MODE/SYNC pin to GND. Selecting PSAVE mode enables automatic activation of PSAVE mode at light loads, thus maximizing efficiency across the full load range. The device will automatically detect the load current at which it should enter PSAVE mode. The device is optimized to track maximum efficiency.

Application Information (continued)

In PSAVE mode (see Figure 1), VOUT regulation is controlled by bursts in switching. While the output voltage is between the low and high voltage thresholds, switching is stopped to reduce loss. When the voltage drops to the lower threshold, the switch bursts at a fixed on time until the upper threshold is reached. At this point the output voltage is allowed to ramp down to the lower threshold without switching to conserve power. In the PSAVE mode, less switching is used. This results in less power loss which can be seen in the difference of efficiency between PWM mode and PSAVE mode at light loads.

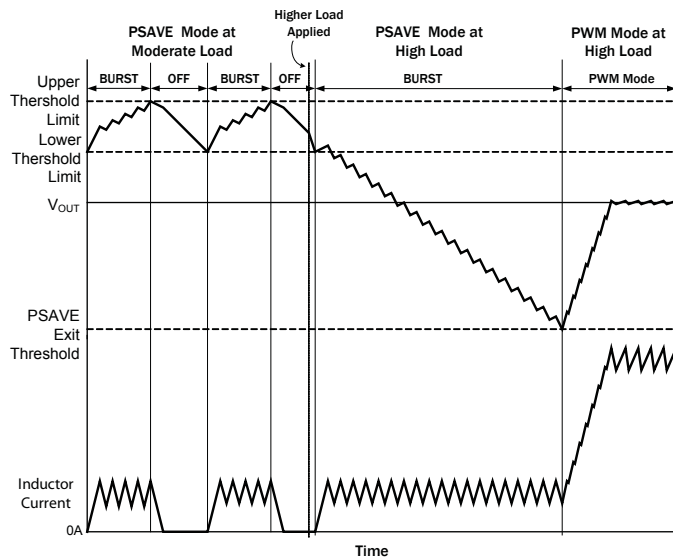

Figure 1 — PSAVE Operation

The PSAVE switching burst frequency is controlled such that the inductor current ripple during the burst is similar to that in PWM mode.

The SC198A automatically detects when to exit PSAVE mode. The device sets a maximum peak current in PSAVE mode, and then detects when VOUT falls due to the load increasing above the level that the peak current will support.

For the SC198A to exit PSAVE mode, the load must be increased, which causes VOUT to decrease until the PSAVE exit threshold is reached. PSAVE levels are set high to minimize the undershoot when the SC198A exits PSAVE. Figure 1 shows PSAVE mode operation and exiting into PWM mode at increased load.

Protection Features

The SC198A provides the following protection features:

- Thermal Shutdown
- Current Limit
- Over-Voltage Protection
- Soft-Start

Thermal Shutdown

The SC198A has a thermal shutdown feature to protect against damage if the junction temperature exceeds 145°C. In thermal shutdown, the on-chip power devices are disabled, tri-stating the LX output. Switching resumes when the temperature drops by 10°C. During this time, if the output voltage decreases by more than 60% of its programmed value, a soft-start will be invoked.

Current Limit

The internal power devices are protected by current limit functions. In the event of a short to ground on the output, the part enters frequency foldback mode. This causes the switching frequency to decrease by a factor determined by the output voltage. This prevents the inductor current from staircasing.

Over-Voltage Protection

In the event of an over-voltage on the output in switcher mode, the PWM drive is disabled, effectively tri-stating the LX output. The part will not resume switching until the output voltage has fallen below 2% of the regulation voltage.

Soft-Start

The soft-start mode operates by limiting the current through the inductor and controlling the switching frequency. The current limit is increased over several milliseconds in discrete steps. This has the desired effect of limiting in-rush current from the input supply. The soft-start mode is cancelled once the output reaches regulation. Soft-start is only re-enabled by power cycling, toggling enable, a UVLO event, or shutdown.

Applications Information (continued)

Inductor Selection

The SC198A was designed for optimum performance when using a 4.7µH inductor. The magnitude of the inductor current ripple is dependent on the inductor value and is determined by the equation

$$\Delta I_L = \frac{V_{OUT}}{L \times f_{osc}} \left(1 + \frac{V_{OUT}}{V_{IN}} \right)$$

This equation demonstrates the relationship between input voltage, output voltage, and inductor ripple current. The inductor should also have a low DCR to minimize the conduction losses and maximize efficiency. The minimum DC current rating of the inductor should be equal to the maximum load current plus half of the inductor current ripple as shown by the equation

$$I_{L(Peak)} = I_{OUT(MAX)} + \frac{\Delta I_L}{2}$$

Final inductor selection will depend on various design considerations such as efficiency, EMI, size, and cost. Table 2 lists some manufacturers of practical inductor options.

Table 2 — Recommended Inductors

Manufacturer/ Part No.	Value (µH)	DCR (Ω)	Rate Current (A)	Tolerance (+%)	Dimensions LxWxH (mm)
Coilcraft LP06610-472ML	4.7	0.20	1.1	±20	6.60 × 5.50 × 1.10
Coilcraft 1812PS-472KLB	4.7	0.11	2.10	±20	5.87 × 4.89 × 3.81
Coilcraft D01608C-472ML	4.7	0.09	1.5	±20	6.60 × 4.50 × 13.0

Capacitor Selection

Input Capacitor

The source input current to a buck converter is non-continuous. To prevent large input voltage ripple a low ESR ceramic capacitor is required. A minimum value of 4.7µF should be used for sufficient input voltage filtering and a 22µF MLCC may be used for optimum input voltage filtering.

Output Capacitor

Output voltage ripple is dominated by the filter capacitance ESR as shown in the equation

$$V_{OUT(P-P)} = \Delta I_L \times ESR_{COUT}$$

Capacitors with X7R or X5R ceramic dielectric are strongly recommended for their low ESR and superior temperature and voltage characteristics. Y5V capacitors should not be used as their temperature coefficients make them unsuitable for this application.

When selecting capacitors for the application, first consider the DC voltage characteristic of the capacitor. The capacitance value at the DC operating voltage may be considerably lower than the rated value. Table 3 lists recommended capacitor values which have been chosen to minimize the impact of this limitation. A 10µF ceramic capacitor is the minimum recommended value for the output filter capacitor. It is important to ensure the capacitor value does not drop below 9µF for the operating range of the application.

Table 3 — Recommended Capacitors

Manufacturer/ Part No.	Value (µF)	Rated Voltage (VDC)	Type	Case Size
Murata GRM21BR60J226ME39	22	6.3	X5R	0805
Murata GRM188R60J106ME47	10	6.3	X5R	0603
Murata GRM21BR60J106KE01B	10	6.3	X5R	0805

Applications Information (continued)

PCB Layout Considerations

Poor layout can degrade the performance of the DC-DC converter and can be a contributory factor in EMI problems, ground bounce, thermal issues, and resistive voltage losses. Poor regulation and instability can result.

The following design rules are recommended:

1. Place the inductor and filter capacitors as close to the device as possible and use short wide traces between the power components.
2. Route the output voltage feedback path away from inductor and LX node to minimize noise and magnetic interference.
3. Use a ground plane to further reduce noise interference on sensitive circuit nodes.

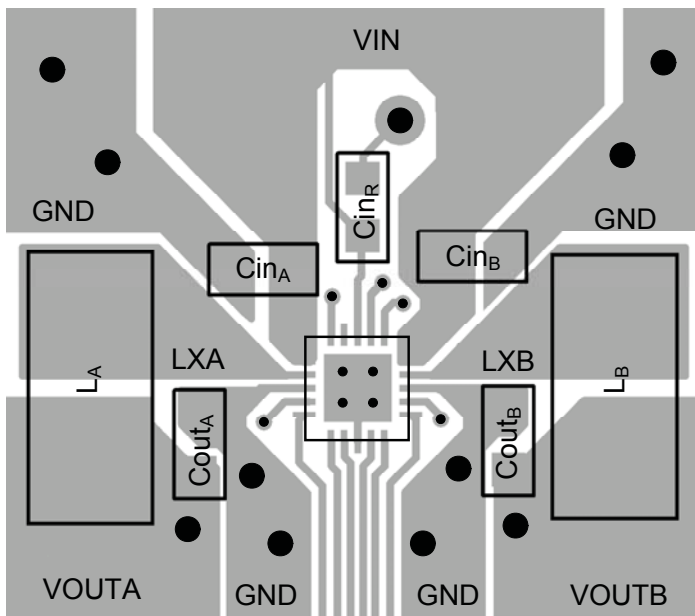

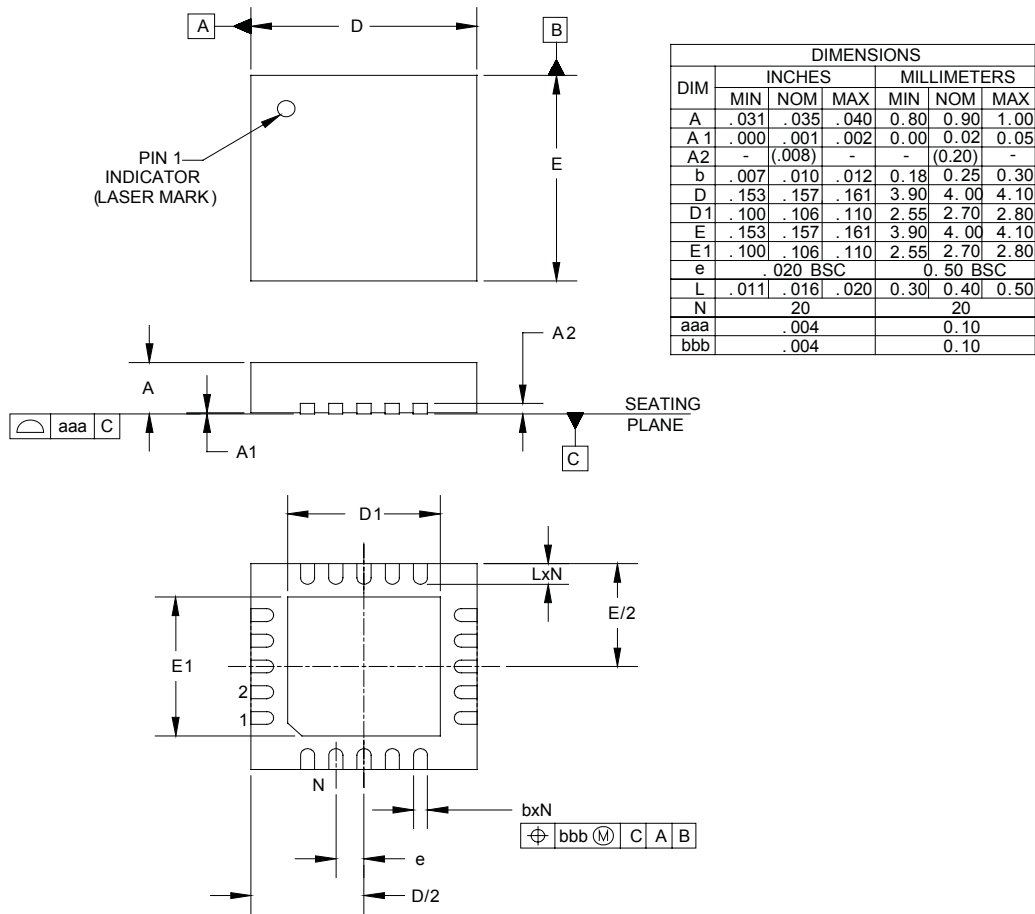
Outline Drawing – MLPQ-20 4x4

- NOTES :
1. CONTROLLING DIMENSIONS ARE IN MILLIMETERS (ANGLES IN DEGREES).
 2. COPLANARITY APPLIES TO THE EXPOSED PAD AS WELL AS THE TERMINALS

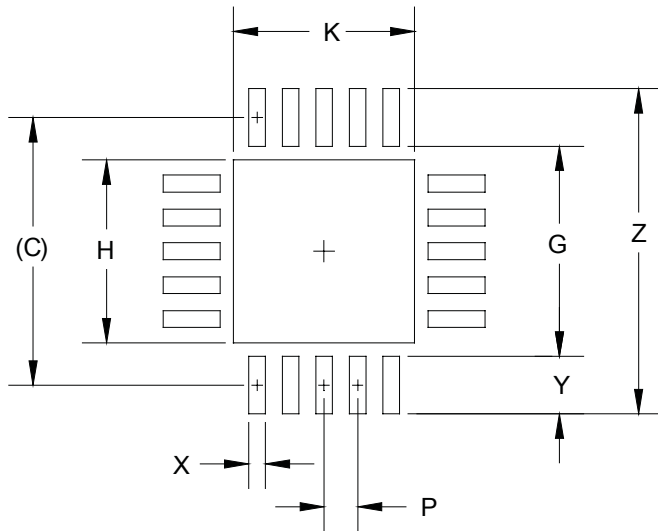
Land Pattern – MLPQ-20 4x4

DIMENSIONS		
DIM	INCHES	MILLIMETERS
C	(.155)	(3.95)
G	.122	3.10
H	.106	2.70
K	.106	2.70
P	.021	0.50
X	.010	0.25
Y	.033	0.85
Z	.189	4.80

NOTES

1. THIS LAND PATTERN IS FOR REFERENCE PURPOSES ONLY
CONSULT YOUR MANUFACTURING GROUP TO ENSURE YOUR
COMPANY'S MANUFACTURING GUIDELINES ARE MET

Contact Information

Semtech Corporation
 Power Mangement Products Division
 200 Flynn Road, Camarillo, CA 93012
 Phone: (805) 498-2111 Fax: (805) 498-3804

www.semtech.com