

TRISIL™ FOR TELECOM EQUIPMENT PROTECTION

FEATURES

- Bidirectional crowbar protection
- Voltage: 8V
- Low leakage current : $I_R = 2\mu\text{A max}$
- Holding current: $I_H = 150\text{ mA min}$
- Repetitive peak pulse current :
 $I_{PP} = 75\text{ A (10/1000}\mu\text{s)}$

MAIN APPLICATIONS

Any sensitive equipment requiring protection against lightning strikes and power crossing:

- Ethernet, T1/E1

DESCRIPTION

The SMP75-8 is a very low voltage transient surge arrester especially designed to protect sensitive telecommunication equipment against lightning strikes and other transients. Its low voltage makes it suitable to protect low voltage transformer in T1/E1, ethernet links without saturation of the transformer.

BENEFITS

Trisils are not subject to ageing and provide a fail safe mode in short circuit for a better protection. They are used to help equipment to meet main standards such as UL1950, IEC950 / CSA C22.2 and UL1459. They have UL94 V0 approved resin. SMB package is JEDEC registered (DO-214AA). Trisils comply with the following standards GR-1089 Core, ITU-T-K20/K21, VDE0433, VDE0878, IEC61000-4-5 and FCC part 68.

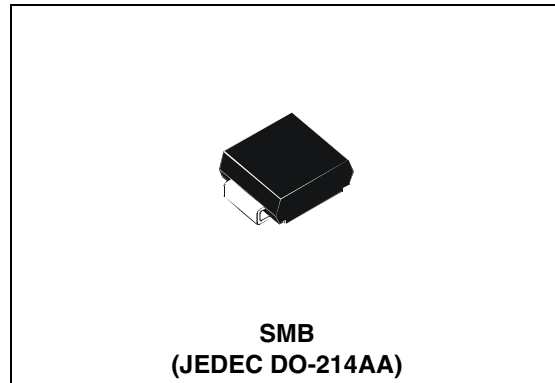


Table 1: Order Code

Part Number	Marking
SMP75-8	L08

Figure 1: Schematic Diagram

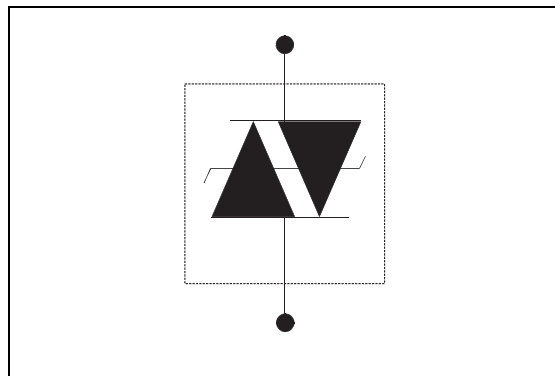


Table 2: In compliances with the following standards

STANDARD	Peak Surge Voltage (V)	Waveform Voltage	Required peak current (A)	Current waveform	Minimum serial resistor to meet standard (Ω)
GR-1089 Core First level	2500	2/10 μ s	500	2/10 μ s	5
	1000	10/1000 μ s	100	10/1000 μ s	3.3
GR-1089 Core Second level	5000	2/10 μ s	500	2/10 μ s	10
GR-1089 Core Intra-building	1500	2/10 μ s	100	2/10 μ s	0
ITU-T-K20/K21	6000	10/700 μ s	150	5/310 μ s	10
	1500		37.5		0
ITU-T-K20 (IEC61000-4-2)	8000	1/60 ns	ESD contact discharge		0
	15000		ESD air discharge		0
VDE0433	4000	10/700 μ s	100	5/310 μ s	0
	2000		50		0
VDE0878	4000	1.2/50 μ s	100	1/20 μ s	0
	2000		50		0
IEC61000-4-5	4000	10/700 μ s	100	5/310 μ s	0
	4000	1.2/50 μ s	100	8/20 μ s	0
FCC Part 68, lightning surge type A	1500	10/160 μ s	200	10/160 μ s	2.5
	800	10/560 μ s	100	10/560 μ s	0
FCC Part 68, lightning surge type B	1000	9/720 μ s	25	5/320 μ s	0

Table 3: Absolute Ratings ($T_{amb} = 25^{\circ}\text{C}$)

Symbol	Parameter		Value	Unit
I_{PP}	Repetitive peak pulse current	10/1000 μ s	75	A
		8/20 μ s	250	
		10/560 μ s	100	
		5/310 μ s	120	
		10/160 μ s	150	
		1/20 μ s	250	
		2/10 μ s	250	
I_{FS}	Fail-safe mode : maximum current (note 1)	8/20 μ s	5	kA
I_{TSM}	Non repetitive surge peak on-state current (sinusoidal)	t = 0.2 s	14	A
		t = 1 s	8	
		t = 2 s	6.5	
		t = 15 mn	2	
I^2t	I^2t value for fusing	t = 16.6 ms	12	A^2s
		t = 20 ms	12.2	
T_{stg}	Storage temperature range		-55 to 150	$^{\circ}\text{C}$
T_j	Maximum junction temperature		150	$^{\circ}\text{C}$
T_L	Maximum lead temperature for soldering during 10 s.		260	$^{\circ}\text{C}$

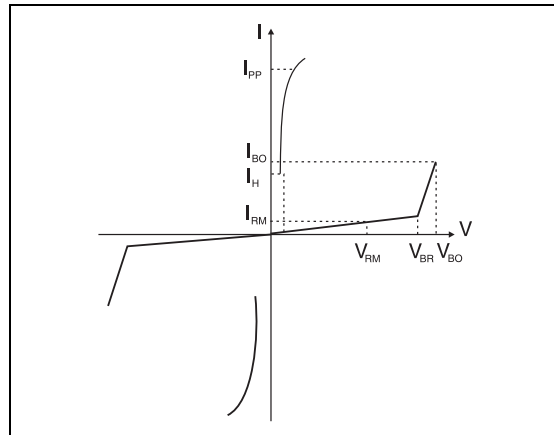
Note 1: in fail safe mode, the device acts as a short circuit

Table 4: Thermal Resistances

Symbol	Parameter	Value	Unit
$R_{th(j-a)}$	Junction to ambient (with recommended footprint)	100	°C/W
$R_{th(j-l)}$	Junction to leads	20	°C/W

Table 5: Electrical Characteristics ($T_{amb} = 25^{\circ}C$)

Symbol	Parameter
V_{RM}	Stand-off voltage
V_{BR}	Breakdown voltage
V_{BO}	Breakover voltage
I_{RM}	Leakage current
I_{PP}	Peak pulse current
I_{BO}	Breakover current
I_H	Holding current
V_R	Continuous reverse voltage
I_R	Leakage current at V_R
C	Capacitance



Types	$I_{RM} @ V_{RM}$		$I_R @ V_R$		Dynamic V_{BO}	Static $V_{BO} @ I_{BO}$		I_H	C
	max.		max. note1		max. note 2	max.	max.	typ.	max.
	μA	V	μA	V	V	V	mA	mA	note 5
SMP75-8	2	6	5	8	20	15	800	50	60

- Note 1:** I_R measured at V_R guarantee $V_{BR} min \geq V_R$
- Note 2:** see functional test circuit 1
- Note 3:** see test circuit 2
- Note 4:** see functional holding current test circuit 3
- Note 5:** $V_R = 2V$ bias, $V_{RMS}=1V$, $F=1MHz$

Figure 2: Pulse waveform

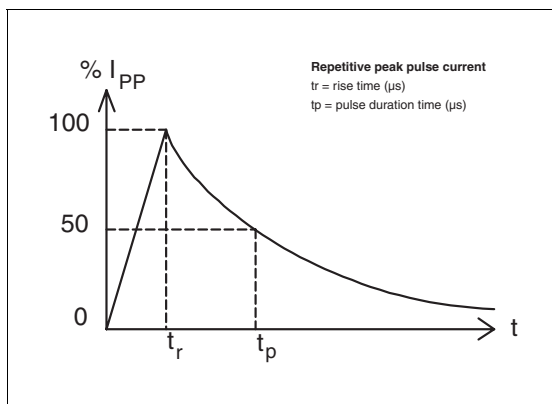


Figure 3: Non repetitive surge peak on-state current versus overload duration

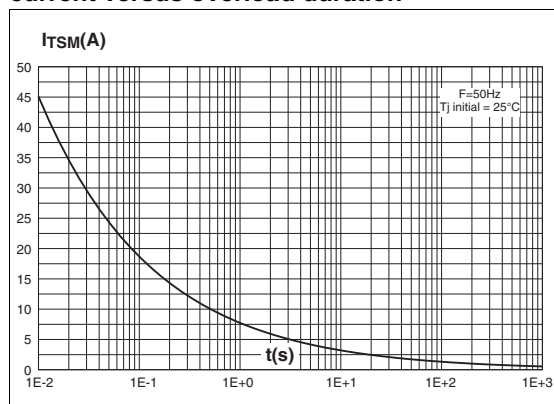


Figure 4: On-state voltage versus on-state current (typical values)

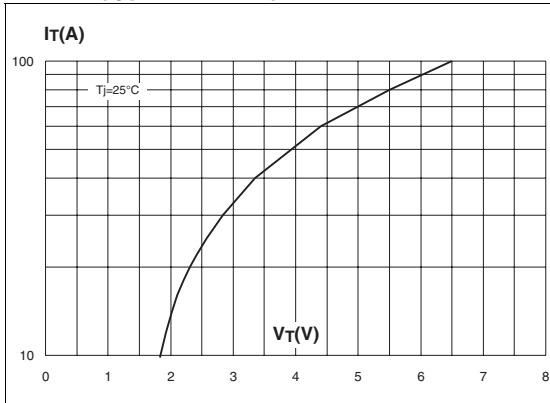


Figure 5: Relative variation of holding current versus junction temperature

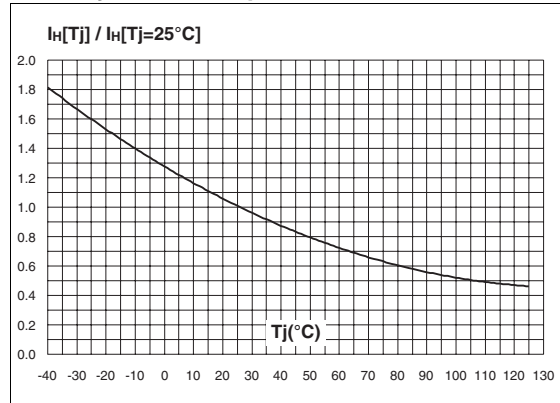


Figure 6: Relative variation of breakover voltage versus junction temperature

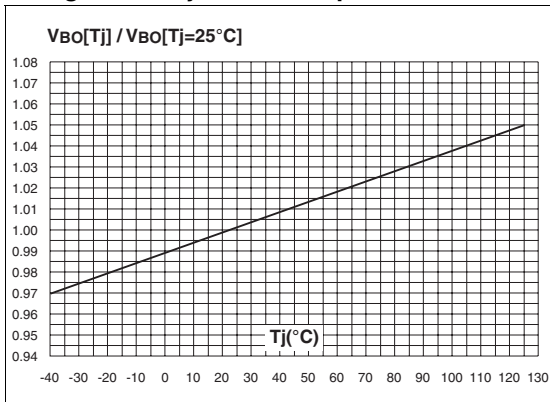


Figure 7: Relative variation of leakage current versus reverse voltage applied (typical values)

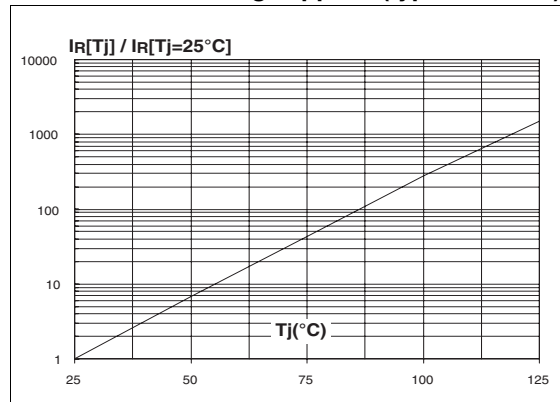


Figure 8: Variation of thermal impedance junction to ambient versus pulse duration (Printed circuit board FR4, SCu=35µm, recommended pad layout)

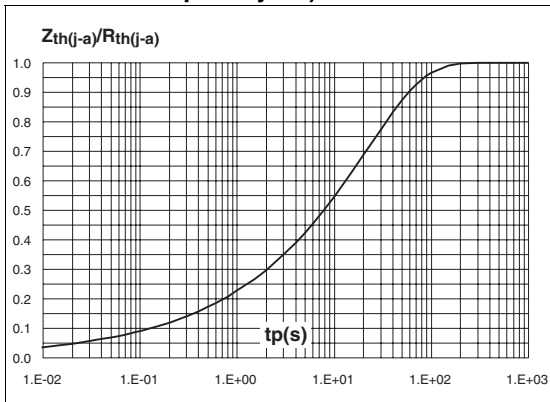


Figure 9: Relative variation of junction capacitance versus reverse voltage applied (typical values)

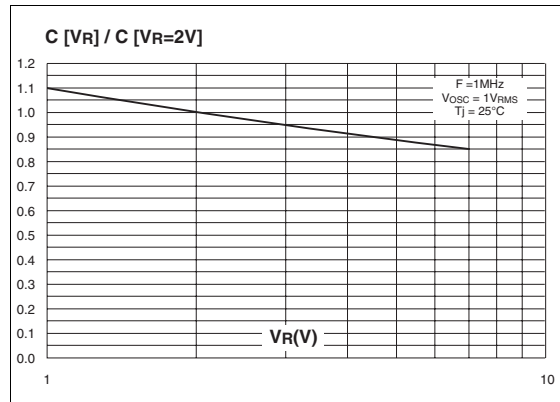


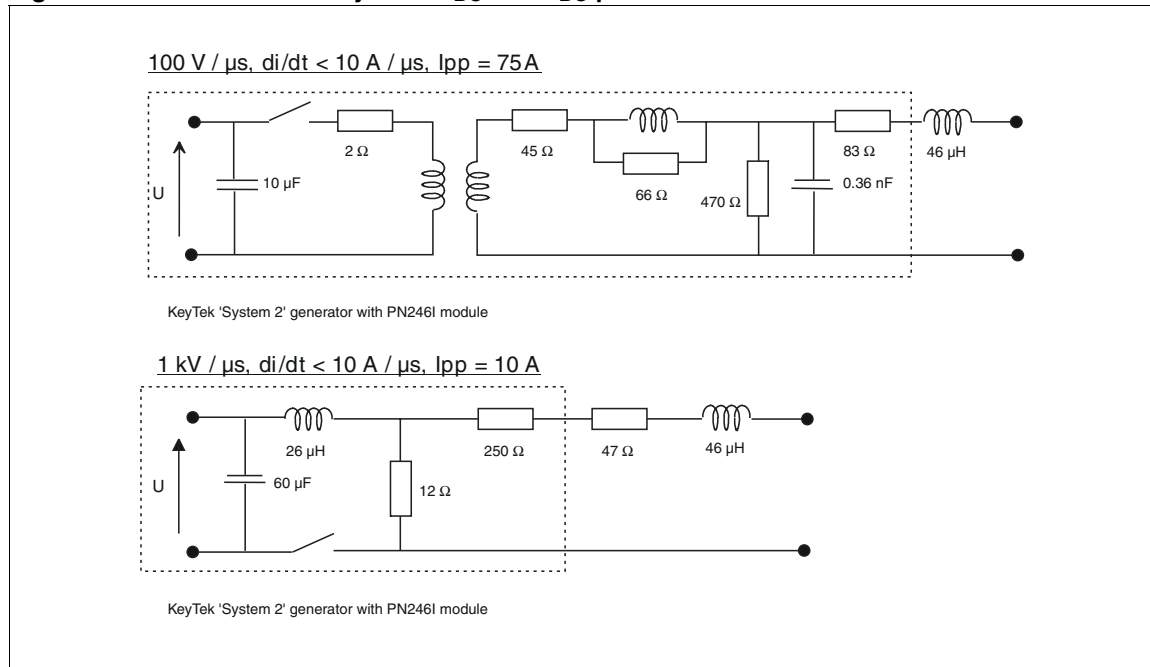
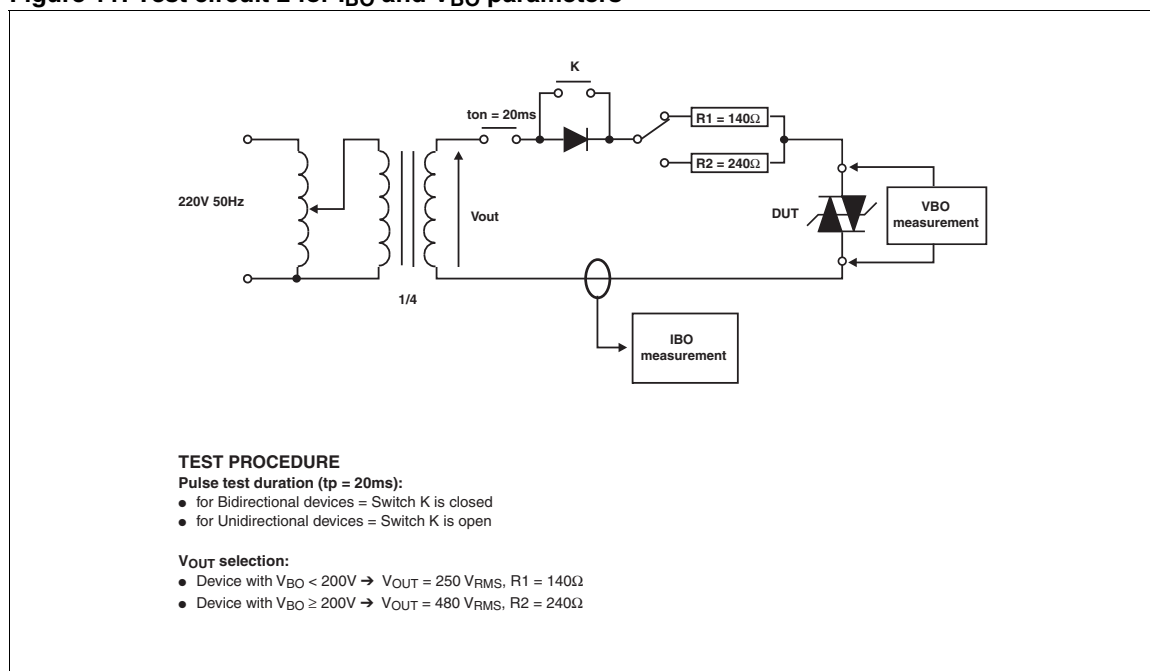
Figure 10: Test circuit 1 for dynamic I_{BO} and V_{BO} parametersFigure 11: Test circuit 2 for I_{BO} and V_{BO} parameters

Figure 12: Test circuit 3 for dynamic I_H parameter

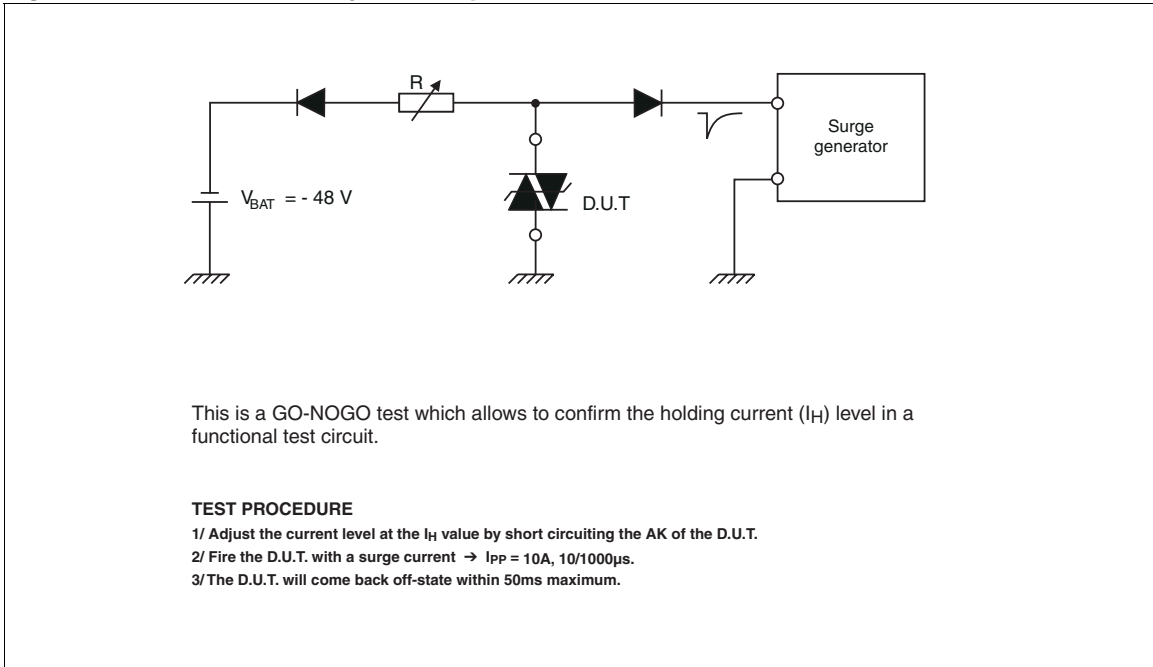


Figure 12: Ordering Information Scheme

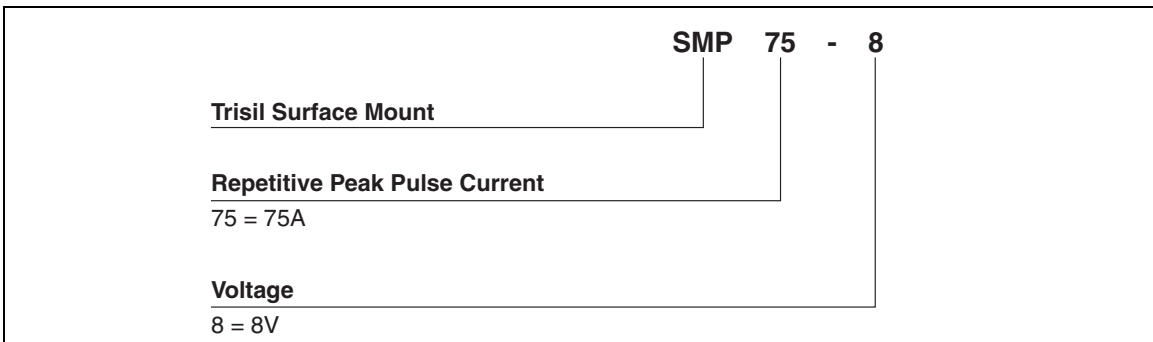


Figure 13: SMB Package Mechanical data

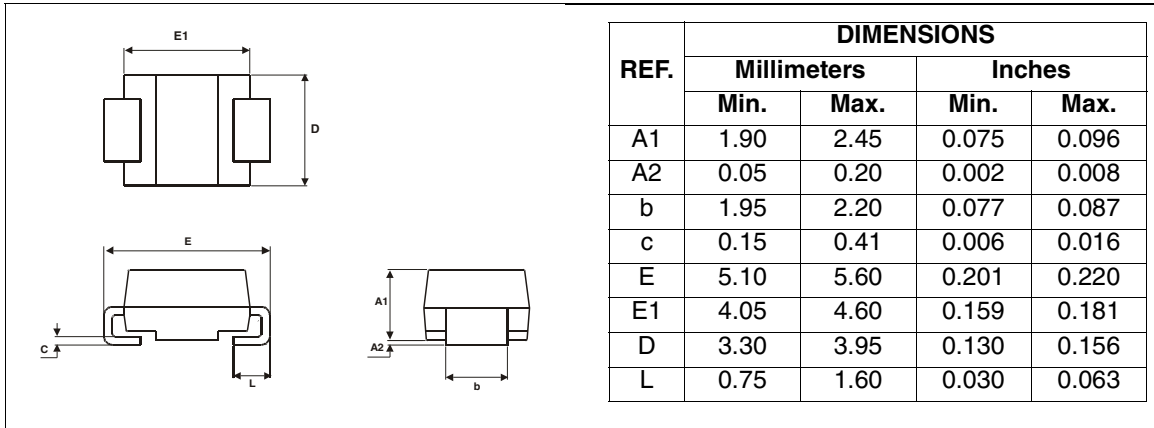
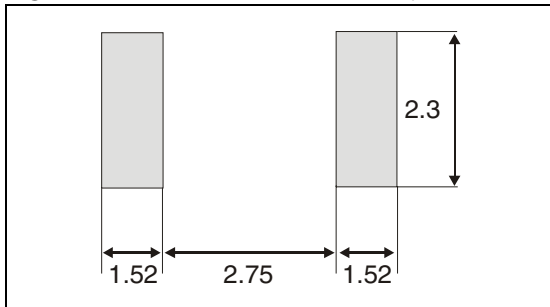


Figure 14: Foot Print Dimensions (in millimeters)



In order to meet environmental requirements, ST offers these devices in ECOPACK® packages. These packages have a Lead-free second level interconnect . The category of second level interconnect is marked on the package and on the inner box label, in compliance with JEDEC Standard JESD97. The maximum ratings related to soldering conditions are also marked on the inner box label. ECOPACK is an ST trademark. ECOPACK specifications are available at: www.st.com.

Table 6: Ordering Information

Part Number	Marking	Package	Weight	Base qty	Delivery mode
SMP75-8	L08	SMB	0.11 g	2500	Tape & reel

Table 7: Revision History

Date	Revision	Description of Changes
19-July-2005	3	Previous issue
02-Jan-2006	4	Added ECOPACK statement and changed page layout. Minor updates to technical values in Tables 2, 3, and 5.

Information furnished is believed to be accurate and reliable. However, STMicroelectronics assumes no responsibility for the consequences of use of such information nor for any infringement of patents or other rights of third parties which may result from its use. No license is granted by implication or otherwise under any patent or patent rights of STMicroelectronics. Specifications mentioned in this publication are subject to change without notice. This publication supersedes and replaces all information previously supplied. STMicroelectronics products are not authorized for use as critical components in life support devices or systems without express written approval of STMicroelectronics.

The ST logo is a registered trademark of STMicroelectronics.
All other names are the property of their respective owners

© 2006 STMicroelectronics - All rights reserved

STMicroelectronics group of companies

Australia - Belgium - Brazil - Canada - China - Czech Republic - Finland - France - Germany - Hong Kong - India - Israel - Italy - Japan -
Malaysia - Malta - Morocco - Singapore - Spain - Sweden - Switzerland - United Kingdom - United States of America
www.st.com