



Film capacitors

MKP Snubbers

Series/Type: B32656S

Date: August 2007
Version: 2

© EPCOS AG 2007. Reproduction, publication and dissemination of this data sheet, enclosures hereto and the information contained therein without EPCOS' prior express consent is prohibited.

MKP capacitors for snubbing



Climatic

- Maximum operating temperature 100 °C
- Climatic category (IEC 60068-1): 55/100/56

Construction

- Dielectric: Polypropylene (MKP) film
- Wound technology with internal series connection
- Plastic case (UL 94 V-0)
- Epoxy resin sealing (UL 94 V-0)

Terminals

- Strap terminals, tinned copper (maximum torque 10 Nm)

Marking

Manufacturer's logo, ordering code, style (MKP), rated capacitance (coded), cap. tolerance (code letter), rated DC voltage, date of manufacture (coded)

Delivery mode

Bulk

Dimensional drawing

T1 (code no. 561)

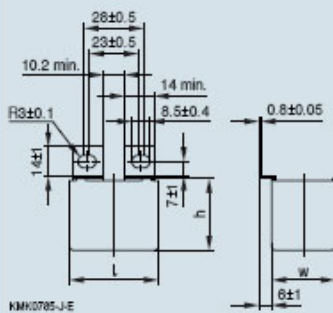

T2 (code no. 562)

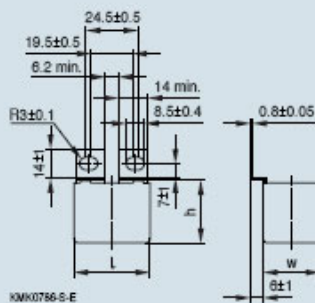

T3 (code no. 563)

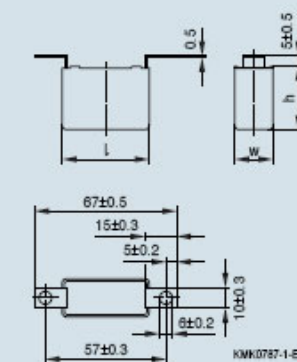

T4 (code no. 564)

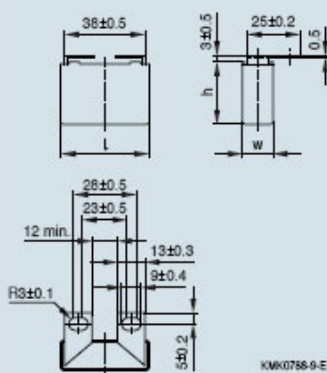

T5 (code no. 565)

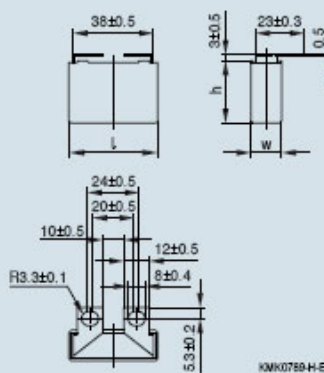

T6 (code no. 566)

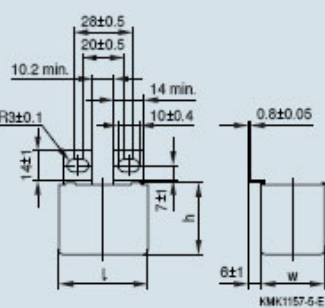

Characteristics and ordering codes											
C _R μF	Max. dimensions w x h x l mm	Ordering code	Terminals						dv/dt V/μs	ESR 100 kHz mΩ	I _{rms} 100 kHz A
			T1	T2	T3	T4	T5	T6			
V_R = 850 V DC / V_{rms} = 450 V AC											
0.22	12 x 22.5 x 42	B32656S8224+***							400	10	5
0.27	12 x 22.5 x 42	B32656S8274+***							400	9	6
0.33	12 x 22.5 x 42	B32656S8334+***							400	9	6
0.39	12 x 22.5 x 42	B32656S8394+***							400	8	7
0.47	12 x 22.5 x 42	B32656S8474+***							400	8	8
0.56	14 x 25 x 42	B32656S8564+***							400	7	8
0.68	16 x 28.5 x 42	B32656S8684+***							400	6	9
0.82	16 x 28.5 x 42	B32656S8824+***							400	6	10
1.00	18 x 32.5 x 42	B32656S8105+***							400	6	11
1.20	18 x 32.5 x 42	B32656S8125+***							400	5	11
1.50	31 x 26.5 x 43.6	B32656S8155+***							400	5	13
1.80	28 x 37 x 42	B32656S8185+***							400	4.5	15
2.20	30 x 45 x 42	B32656S8255+***							400	3.5	17
V_R = 1000 V DC / V_{rms} = 480 V AC											
0.22	12 x 22.5 x 42	B32656S0224+***							450	10	6
0.27	12 x 22.5 x 42	B32656S0274+***							450	9	7
0.33	14 x 25 x 42	B32656S0334+***							450	9	7
0.39	14 x 25 x 42	B32656S0394+***							450	8	8
0.47	14 x 25 x 42	B32656S0474+***							450	8	9
0.56	16 x 28.5 x 42	B32656S0564+***							450	7	9
0.68	16 x 28.5 x 42	B32656S0684+***							450	6	10
0.82	18 x 32.5 x 42	B32656S0824+***							450	6	11
1.00	20 x 39.5 x 42	B32656S0105+***							450	6	12
1.20	20 x 39.5 x 42	B32656S0125+***							450	5	13
1.50	30 x 45 x 42	B32656S0155+***							450	5	15
1.80	30 x 45 x 42	B32656S0185+***							450	4.5	16
V_R = 1250 V DC / V_{rms} = 500 V AC											
0.12	12 x 22.5 x 42	B32656S7124+***							500	15	5
0.15	12 x 22.5 x 42	B32656S7154+***							500	15	6
0.22	14 x 25 x 42	B32656S7224+***							500	10	8
0.27	14 x 25 x 42	B32656S7274+***							500	9	8
0.33	16 x 28.5 x 42	B32656S7334+***							500	9	8
0.39	18 x 32.5 x 42	B32656S7394+***							500	8	9
0.47	18 x 32.5 x 42	B32656S7474+***							500	8	9
0.56	20 x 39.5 x 42	B32656S7564+***							500	7	10
0.68	20 x 39.5 x 42	B32656S7684+***							500	6	10
0.82	28 x 37 x 42	B32656S7824+***							500	6	11
1.00	28 x 37 x 42	B32656S7105+***							500	6	13
1.20	30 x 45 x 42	B32656S7125+***							500	5	14

Available terminal types

+ = Capacitance tolerance code
 J = ±5%
 K = ±10%

*** = Terminal configuration

T1 = 561
 T2 = 562
 T3 = 563
 T4 = 564
 T5 = 565
 T6 = 566

Characteristics and ordering codes

C _R μF	Max. dimensions w x h x l mm	Ordering code	Terminals						dv/dt V/μs	ESR 100 kHz mΩ	I _{rms} 100 kHz A
			T1	T2	T3	T4	T5	T6			
V_R = 1600 V DC / V_{rms} = 750 V AC											
0.068	12 x 22.5 x 42	B32656S1683+***							600	25	5
0.10	12 x 22.5 x 42	B32656S1104+***							600	20	6
0.12	14 x 25 x 42	B32656S1124+***							600	15	6
0.15	14 x 25 x 42	B32656S1154+***							600	15	7
0.22	16 x 28.5 x 42	B32656S1224+***							600	10	9
0.27	18 x 32.5 x 42	B32656S1274+***							600	9	10
0.33	20 x 39.5 x 42	B32656S1334+***							600	9	10
0.39	28 x 37 x 42	B32656S1394+***							600	8	11
0.47	28 x 37 x 42	B32656S1474+***							600	8	12
0.56	30 x 45 x 42	B32656S1564+***							600	7	13
0.68	30 x 45 x 42	B32656S1684+***							600	6	14
V_R = 2000 V DC / V_{rms} = 800 V AC											
0.047	12 x 22.5 x 42	B32656S2473+***							700	35	5
0.068	14 x 25 x 42	B32656S2683+***							700	25	6
0.10	14 x 25 x 42	B32656S2104+***							700	20	7
0.12	16 x 28.5 x 42	B32656S2124+***							700	15	7
0.15	18 x 32.5 x 42	B32656S2154+***							700	15	8
0.22	20 x 39.5 x 41.5	B32656S2224+***							700	10	10
0.27	28 x 37 x 42	B32656S2274+***							700	9	11
0.33	28 x 37 x 42	B32656S2334+***							700	9	12
0.39	30 x 45 x 42	B32656S2394+***							700	8	13
0.47	30 x 45 x 42	B32656S2474+***							700	8	15

Available terminal types

+ = Capacitance tolerance code
 J = ±5%
 K = ±10%

*** = Terminal configuration
 T1 = 561
 T2 = 562
 T3 = 563
 T4 = 564
 T5 = 565
 T6 = 566

Technical data

Operating temperature range	Max. operating temperature $T_{op,max}$	+100 °C		
	Upper category temperature T_{max}	+100 °C		
	Lower category temperature T_{min}	-55 °C		
	Rated temperature T_R	+85 °C		
Dissipation factor $\tan \delta$ (in 10^{-3}) at 20 kHz and 20 °C (upper limit values)	at	$C_R \leq 0.1 \mu F$	$0.1 \mu F < C_R \leq 1 \mu F$	$C_R > 1 \mu F$
	1 kHz	–	0.5	0.5
	10 kHz	–	0.8	1.5
	100 kHz	5.0	–	–
Insulation resistance R_{ins} or time constant $\tau = C_R \cdot R_{ins}$ at 20 °C, rel. humidity $\leq 65\%$ (minimum as-delivered values)	$C_R \leq 0.33 \mu F$	$C_R \leq 0.33 \mu F$		
	100 G Ω	30 000 s		
DC test voltage	1.6 · V_R , 2 s			
Category voltage V_C (continuous operation with V_{DC} or V_{AC} at $f \leq 1$ kHz)	T_A (°C)	DC voltage derating	AC voltage derating	
	$T_A \leq 85$ $85 < T_A \leq 100$	$V_C = V_R$ $V_C = V_R \cdot (165 - T_A) / 80$	$V_{C,rms} = V_{R,rms}$ $V_{C,rms} = V_{R,rms} \cdot (165 - T_A) / 80$	
Operating voltage V_{op} for short operating periods (V_{DC} or V_{AC} at $f \leq 1$ kHz)	T_A (°C)	DC voltage (max. hours)	AC voltage (max. hours)	
	$T_A \leq 85$ $85 < T_A \leq 100$	$V_{op} = 1.25 \cdot V_C$ (2000 h) $V_{op} = 1.25 \cdot V_C$ (1000 h)	$V_{op} = 1.0 \cdot V_{C,rms}$ (2000 h) $V_{op} = 1.0 \cdot V_{C,rms}$ (1000 h)	
Damp heat test	56 days / 40 °C / 93% relative humidity			
Limit values after damp heat test	Capacitance change ($\Delta C/C$)	$\leq 3\%$		
	Dissipation factor change ($\Delta \tan \delta$)	$\leq 0.3 \cdot 10^{-3}$ (at 1 kHz) $\leq 1.0 \cdot 10^{-3}$ (at 10 kHz)		
	Insulation resistance R_{ins} or time constant $\tau = C_R \cdot R_{ins}$	$\geq 50\%$ of minimum as-delivered values		
Reliability:				
Failure rate λ	1 fit ($\leq 1 \cdot 10^{-9}/h$) at 0.5 · V_R , 40 °C			
Service life t_{SL}	up to 200 000 h at 1.0 · V_R , 40 °C			
For conversion to other operating conditions and temperatures refer to chapter "Quality assurance", data book 2005 "Film Capacitors", page 390.				
Failure criteria:				
Total failure	Short circuit or open circuit			
Failure due to variation of parameters	Capacitance change ($\Delta C/C$)		$> 10\%$	
	Dissipation factor $\tan \delta$		> 4 times upper limit value	
	Insulation resistance R_{ins}		$< 1500 M\Omega$ ($C_R \leq 0.33 \mu F$)	
	or time constant $\tau = C_R \cdot R_{ins}$		< 500 s ($C_R \leq 0.33 \mu F$)	

Pulse handling capability

"dv/dt" values represent the maximum permissible voltage change per unit of time for non-sinusoidal voltages, expressed in V/ μ s.

" k_0 " represents the maximum permissible pulse characteristic of the waveform applied to the capacitor, expressed in V^2/μ s.

Note: The maximum values of dv/dt and k_0 must not be exceeded in order to avoid damaging the capacitor.

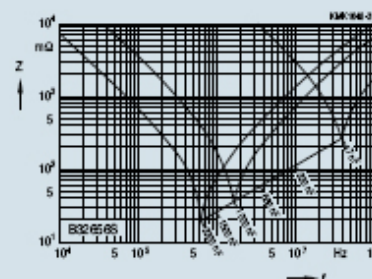
Impedance versus frequency curve (typical values)

Cautions and Warnings

- Do not exceed the upper category temperature (UCT).
- Do not apply any mechanical stress to the capacitor terminals.
- Avoid any compressive, tensile or flexural stress.
- Do not move the capacitor after it has been soldered to the PC board.
- Do not pick up the PC board by the soldered capacitor.
- Do not place the capacitor on a PC board whose hole space differs from the specified lead space.
- Do not exceed the specified time or temperature limits during soldering.
- Avoid external energy inputs, such as fire or electricity.
- Avoid overload of the capacitors.

Resistance to soldering heat

Resistance to soldering heat is tested to IEC 60068-2-20, test Tb, method 1A. Conditions:

Series	Solder bath temp.	Soldering time
MKT boxed (except 2.5 x 6.5 x 7.2 mm); coated; MKP/MFP	260 ±5 °C	10 ±1 s
MKT boxed (case 2.5 x 6.5 x 7.2 mm)	260 ±5 °C	5 ±1 s

General notes on soldering

Permissible heat-exposure loads on film capacitors are primarily characterized by the upper category temperature T_{max} . Long exposure to temperatures above this type-related temperature limit can lead to changes in the plastic dielectric and thus irreversibly change a capacitor's electrical characteristics. For short exposure times (as in practical soldering processes), the heat load (and thus the possible effects on the capacitor) will also depend on other factors such as:

- The pre-heating temperature and time.
- The forced cooling immediately after soldering.
- The terminal characteristics: diameter, length, thermal resistance, special configurations (e.g. crimping).
- The height of the capacitor above the solder bath.
- Shadowing by neighboring components.
- Additional heating due to heat dissipation by neighboring components.
- Use of solder-resistant coatings.

The overheating associated with some of these factors can usually be reduced by suitable countermeasures. For example, if a pre-heating step cannot be avoided, an additional or reinforced cooling process may have to be included.

Cleaning

To determine whether a particular solvent, often used to remove flux residues and other substances, is suitable for the capacitors described, please refer to data book 2005 "Film Capacitors", in which this information is available. Even when suitable solvents are used, a reversible change of the electrical characteristics may occur in uncoated capacitors immediately after they have been washed. Thus it is always recommended to dry the components (e.g. 4 h at 70 °C) before they are subjected to subsequent electrical testing.

Embedding of capacitors in finished assemblies

In many applications, finished circuit assemblies are embedded in plastic resins. In this case, both chemical and thermal influences of the embedding ("potting") and

curing processes must be taken into account. Our experience has shown that the following potting materials can be recommended considering maximum curing temperature 100 °C:

- Non-flexible epoxy resins with acid-anhydride hardeners
- Chemically inert, non-conducting fillers

Caution: Consult us first if you also wish to embed other uncoated component types!

Storage conditions

All capacitors listed in this product profile can be stored for short periods at any temperature within the entire range of category temperatures. For long storage periods, however, the following conditions should be observed:

- Storage temperature -40 to +40 °C
- Maximum relative humidity 80%, no dew allowed on the capacitor
- Maximum duration 24 months (12 months for taped components)

Resistance to vibration

A capacitor's ability to withstand vibration (e.g. such as that occurring in applications involving rotating machinery) is tested to IEC 60068-2-6. The test procedure used here involves continuous sinusoidal vibration along three orthogonal axes, with a continuously varying frequency (10 ... 500 Hz), an acceleration amplitude of 10 g, a displacement amplitude of 0.75 mm and a duration of 360 minutes for each axis. EPCOS offers film capacitors specially designed for operation under more severe vibration regimes such as those found in automotive applications. Consult our catalog "Film Capacitors for Automotive Electronics".

Passive flammability

The passive flammability test is applied to ensure that components bearing the corresponding qualification contribute less energy to the combustion behavior of their immediate vicinity than is required to ignite them. This measure is designed to contain any localized fire that may occur. In the respective tests, the capacitors are subjected to a standardized flame to evaluate their combustion behavior by checking whether the flame persists for longer than a maximum permissible period or not. The severity of the test is determined essentially by the test flame and exposure time in accordance with various international standards (IEC 60040 CO 752 (amendment to IEC 60384-1), IEC 60695-2-2 and UL 1414). Unless the detail specifications stipulate otherwise, EMI suppression capacitors are tested to IEC 60384-14, section 4.17, test severity categories B and C.

Important notes

The following applies to all products named in this publication:

1. Some parts of this publication contain **statements about the suitability of our products for certain areas of application**. These statements are based on our knowledge of typical requirements that are often placed on our products in the areas of application concerned. We nevertheless expressly point out **that such statements cannot be regarded as binding statements about the suitability of our products for a particular customer application**. As a rule, EPCOS is either unfamiliar with individual customer applications or less familiar with them than the customers themselves. For these reasons, it is always ultimately incumbent on the customer to check and decide whether an EPCOS product with the properties described in the product specification is suitable for use in a particular customer application.
2. We also point out that **in individual cases, a malfunction of passive electronic components or failure before the end of their usual service life cannot be completely ruled out in the current state of the art, even if they are operated as specified**. In customer applications requiring a very high level of operational safety and especially in customer applications in which the malfunction or failure of a passive electronic component could endanger human life or health (e.g. in accident prevention or life-saving systems), it must therefore be ensured by means of suitable design of the customer application or other action taken by the customer (e.g. installation of protective circuitry or redundancy) that no injury or damage is sustained by third parties in the event of malfunction or failure of a passive electronic component.
3. **The warnings, cautions and product-specific notes must be observed.**
4. In order to satisfy certain technical requirements, **some of the products described in this publication may contain substances subject to restrictions in certain jurisdictions (e.g. because they are classed as “hazardous”)**. Useful information on this will be found in our Material Data Sheets on the Internet (www.epcos.com/material). Should you have any more detailed questions, please contact our sales offices.
5. We constantly strive to improve our products. Consequently, **the products described in this publication may change from time to time**. The same is true of the corresponding product specifications. Please check therefore to what extent product descriptions and specifications contained in this publication are still applicable before or when you place an order.

We also **reserve the right to discontinue production and delivery of products**. Consequently, we cannot guarantee that all products named in this publication will always be available.
6. Unless otherwise agreed in individual contracts, **all orders are subject to the current version of the “General Terms of Delivery for Products and Services in the Electrical Industry” published by the German Electrical and Electronics Industry Association (ZVEI)**.
7. The trade names EPCOS, BAOKE, Alu-X, CeraDiode, CSSP, MiniBlue, MKK, MLSC, MotorCap, PCC, PhaseCap, PhaseMod, SIFI, SIKOREL, SilverCap, SIMDAD, SIMID, SineFormer, SIOV, SIP5D, SIP5K, ThermoFuse, WindCap are **trademarks registered or pending** in Europe and in other countries. Further information will be found on the Internet at www.epcos.com/trademarks.