

**POWER MANAGEMENT****Description**

The SC1211 is a high speed, Combi-Sense™, dual output driver designed to drive high-side and low-side MOSFETs in a synchronous Buck converter. These drivers combined with Combi-Sense PWM controllers, such as Semtech SC2643VX or SC2643, provide a cost effective multi-phase voltage regulator for advanced microprocessors

The Combi-Sense™ is a technique to sense the inductor current for peak current mode control of voltage regulator without using sensing resistor. It provides the following advantages:

- No costly precision sensing resistor
- Lossless current sensing
- High level noise free signal
- Fast response
- Suitable for wide range of duty cycle
- Only two small signal components (third optional)

The detailed explanation of the technique can be found in the Applications Information section.

A 30ns max propagation delay from input transition to the gate of the power FET's guarantees operation at high switching frequencies. Internal overlap protection circuit prevents shoot-through from Vin to PGND in the main and synchronous MOSFETs. The adaptive overlap protection circuit ensures the bottom FET does not turn on until the top FET source has reached 1V, to prevent cross-conduction.

8.5V gate drive provides optimum enhancement of MOSFETs at minimum driver and MOSFET switching loss. High current drive capability allows fast switching, thus reducing switching losses at high (up to 1.5MHz) frequencies without causing thermal stress on the driver.

Under-voltage-lockout and over-temperature shutdown features are included for proper and safe operation. Timed latches and improved robustness are built into the housekeeping functions such as the Under Voltage Lockout and adaptive Shoot-through protection circuitry to prevent false triggering and to assure safe operation. The SC1211 is offered in a Power SOIC-8L package.

**Features**

- ◆ High efficiency
- ◆ +12V supply voltage with internal LDO for optimum gate drive
- ◆ High peak drive current
- ◆ Adaptive non-overlapping gate drives provide shoot-through protection
- ◆ Support Combi-Sense™ and VID-on-fly operations
- ◆ Fast rise and fall times (15ns typical with 3000pf load)
- ◆ Ultra-low (<30ns) propagation delay (BG going low)
- ◆ Floating top gate drive
- ◆ Crowbar function for over voltage protection
- ◆ High frequency (to 1.5 MHz) operation allows use of small inductors and low cost ceramic capacitors
- ◆ Under-voltage-lockout
- ◆ Low quiescent current

**Applications**

- ◆ Intel Pentium™ processor power supplies
- ◆ AMD Athlon™ and K8™ processor power supplies
- ◆ High current low voltage DC-DC converters

**POWER MANAGEMENT**  
Typical Application Circuit

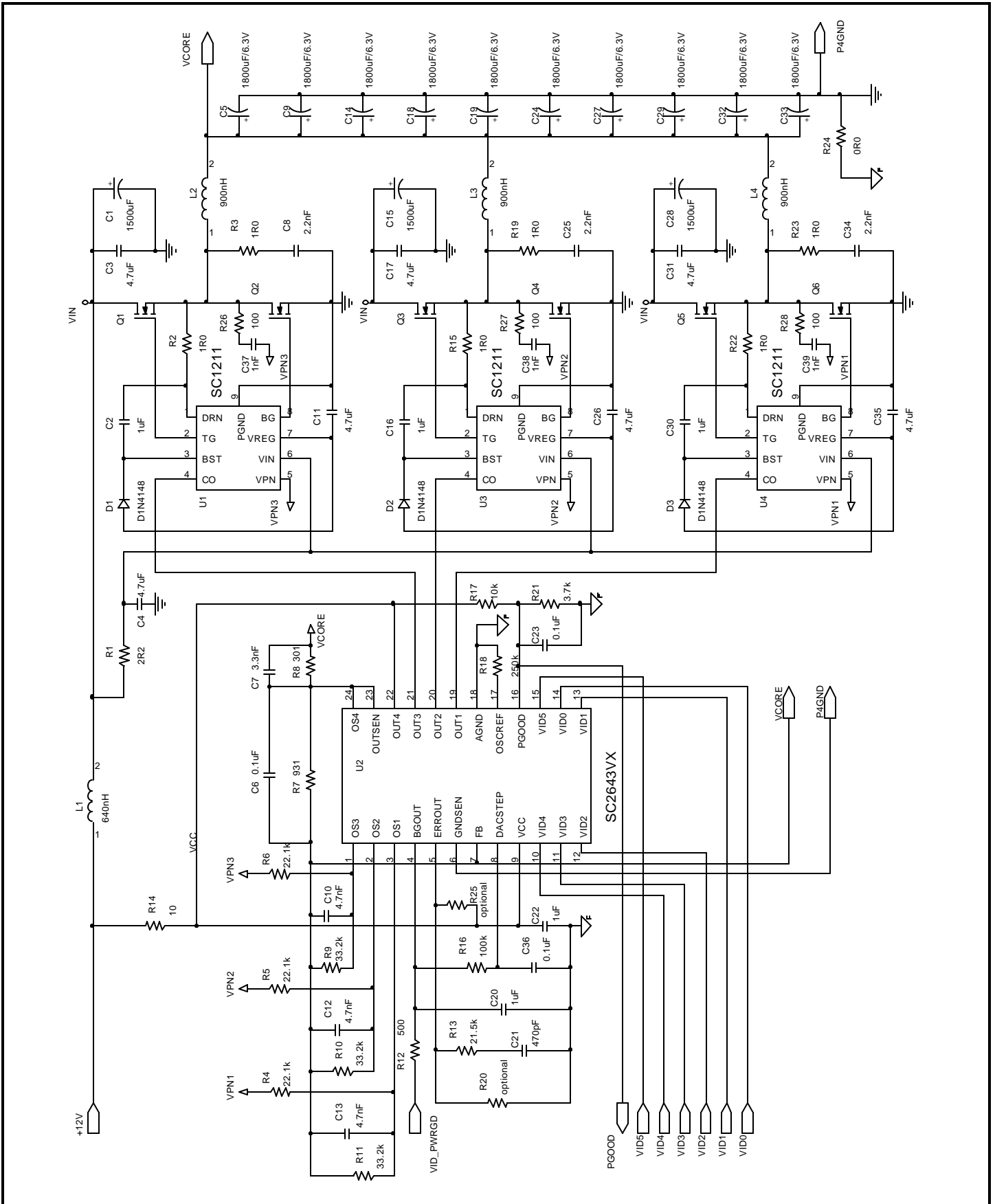

**POWER MANAGEMENT**
**Absolute Maximum Ratings**

Exceeding the specifications below may result in permanent damage to the device, or device malfunction. Operation outside of the parameters specified in the Electrical Characteristics section is not implied.

| Parameter                            | Symbol          | Conditions                              | Maximum     | Units         |
|--------------------------------------|-----------------|-----------------------------------------|-------------|---------------|
| $V_{IN}$ Supply Voltage              | $V_{IN}$        |                                         | 16          | V             |
| BST to DRN                           | $V_{BST-DRN}$   |                                         | 11          | V             |
| BST to PGND                          | $V_{BST-PGND}$  |                                         | 40          | V             |
| BST to PGND Pulse                    | $V_{BST-PULSE}$ | $t_{PULSE} < 100ns$                     | 45          | V             |
| DRN to PGND                          | $V_{DRN-PGND}$  |                                         | -2 to 30    | V             |
| DRN to PGND Pulse                    | $V_{DRN-PULSE}$ | $t_{PULSE} < 200ns$                     | -5 to 35    | V             |
| VPN to PGND                          | $V_{PN}$        |                                         | 16          | V             |
| VPN to PGND Pulse                    | $V_{PN-PULSE}$  | $t_{PULSE} < 100ns$                     | 20          | V             |
| PWM Input                            | CO              |                                         | -0.3 to 8.5 | V             |
| Continuous Power Dissipation         | $P_D$           | $T_A = 25^{\circ}C, T_J = 125^{\circ}C$ | 2.56        | W             |
| Thermal Resistance Junction to Case  | $\theta_{JC}$   |                                         | 8           | $^{\circ}C/W$ |
| Operating Junction Temperature Range | $T_J$           |                                         | 0 to +125   | $^{\circ}C$   |
| Storage Temperature Range            | $T_{STG}$       |                                         | -65 to +150 | $^{\circ}C$   |
| Lead Temperature (Soldering) 10 Sec. | $T_{LEAD}$      |                                         | 300         | $^{\circ}C$   |

**Electrical Characteristics**

Unless specified:  $T_A = 25^{\circ}C$ ;  $V_{IN} = 12V$ ;  $V_{REG} = 8.5V$

| Parameter                            | Symbol           | Conditions                     | Min | Typ | Max | Units |
|--------------------------------------|------------------|--------------------------------|-----|-----|-----|-------|
| <b>Power Supply</b>                  |                  |                                |     |     |     |       |
| Supply Voltage                       | $V_{IN}$         |                                | 9   | 12  | 15  | V     |
| Quiescent Current, Operating         | $I_{q\_op}$      |                                |     | 3.0 |     | mA    |
| <b>Under Voltage Lockout</b>         |                  |                                |     |     |     |       |
| Start Threshold of $V_{REG}$ Voltage | $V_{REG\_START}$ |                                |     | 4   | 4.3 | V     |
| Hysteresis                           | $V_{hys\_UVLO}$  |                                |     | 160 |     | mV    |
| <b>Internal LDO</b>                  |                  |                                |     |     |     |       |
| LDO Output                           | $V_{REG}$        | $V_{IN} = 9V \text{ to } 16V$  |     | 8.5 |     | V     |
| Drop Out Voltage                     | $V_{DROP}$       | $V_{IN} = 5V \text{ to } 8.8V$ |     | 0.3 |     | V     |

**POWER MANAGEMENT**
**Electrical Characteristics (Cont.)**

 Unless specified:  $T_A = 25^\circ\text{C}$ ;  $V_{IN} = 12\text{V}$ ;  $V_{REG} = 8.5\text{V}$ 

| Parameter                               | Symbol          | Conditions                                         | Min | Typ | Max | Units            |
|-----------------------------------------|-----------------|----------------------------------------------------|-----|-----|-----|------------------|
| <b>CO</b>                               |                 |                                                    |     |     |     |                  |
| Logic High Input Voltage                | $V_{CO\_H}$     |                                                    | 2.0 |     |     | V                |
| Logic Low Input Voltage                 | $V_{CO\_L}$     |                                                    |     |     | 0.8 | V                |
| <b>Thermal Shutdown</b>                 |                 |                                                    |     |     |     |                  |
| Over Temperature Trip Point             | $T_{OTP}$       |                                                    |     | 155 |     | $^\circ\text{C}$ |
| Hysteresis                              | $T_{HYST}$      |                                                    |     | 10  |     | $^\circ\text{C}$ |
| <b>High Side Driver (TG)</b>            |                 |                                                    |     |     |     |                  |
| Output Impedance                        | $R_{SRC\_TG}$   | $V_{BST} - V_{DRN} = 8.5\text{V}$                  |     | 1.5 | 3.0 | $\Omega$         |
|                                         | $R_{SINK\_TG}$  |                                                    |     | 1.0 | 2.0 |                  |
| Rise Time                               | $t_{R\_TG}$     | $CL = 3\text{nF}, V_{BST} - V_{DRN} = 8.5\text{V}$ |     | 15  |     | ns               |
| Fall Time                               | $t_{F\_TG}$     | $CL = 3\text{nF}, V_{BST} - V_{DRN} = 8.5\text{V}$ |     | 10  |     | ns               |
| Propagation Delay, TG Going High        | $t_{PDH\_TG}$   | $V_{BST} - V_{DRN} = 8.5\text{V}$                  |     | 37  |     | ns               |
| Propagation Delay, TG Going Low         | $t_{PDL\_TG}$   | $V_{BST} - V_{DRN} = 8.5\text{V}$                  |     | 30  |     | ns               |
| <b>Low-Side Driver (BG)</b>             |                 |                                                    |     |     |     |                  |
| Output Impedance                        | $R_{SRC\_BG}$   | $V_{BST} - V_{DRN} = 8.5\text{V}$                  |     | 1.5 | 3.0 | $\Omega$         |
|                                         | $R_{SINK\_BG}$  |                                                    |     | 1.5 | 3.0 |                  |
| Rise Time                               | $t_{R\_BG}$     | $CL = 3\text{nF}, V_{BST} - V_{DRN} = 8.5\text{V}$ |     | 10  |     | ns               |
| Fall Time                               | $t_{F\_BG}$     | $CL = 3\text{nF}, V_{BST} - V_{DRN} = 8.5\text{V}$ |     | 10  |     | ns               |
| Propagation Delay, BG Going High        | $t_{PDH\_BG}$   | $V_{BST} - V_{DRN} = 8.5\text{V}$                  |     | 20  |     | ns               |
| Propagation Delay, BG Going Low         | $t_{PDL\_BG}$   | $V_{BST} - V_{DRN} = 8.5\text{V}$                  |     | 27  |     | ns               |
| <b>Under-Voltage-Lockout Time Delay</b> |                 |                                                    |     |     |     |                  |
| $V_{REG}$ ramping up                    | $t_{PDH\_UVLO}$ |                                                    |     | 2   |     | $\mu\text{s}$    |
| $V_{REG}$ ramping down                  | $t_{PDL\_UVLO}$ |                                                    |     | 2   |     | $\mu\text{s}$    |

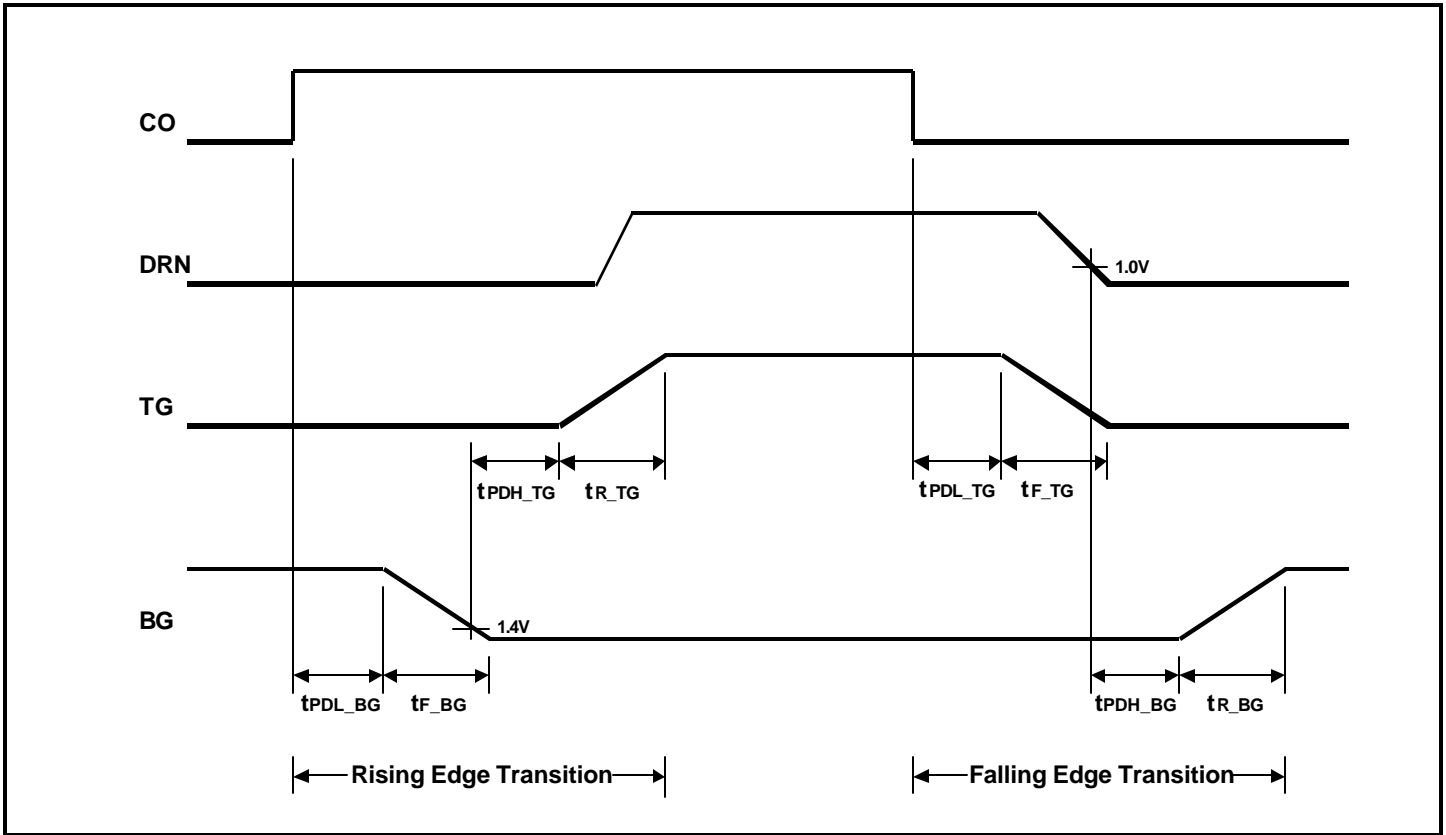
**POWER MANAGEMENT**
**Timing Diagrams**

## POWER MANAGEMENT

## Pin Configuration

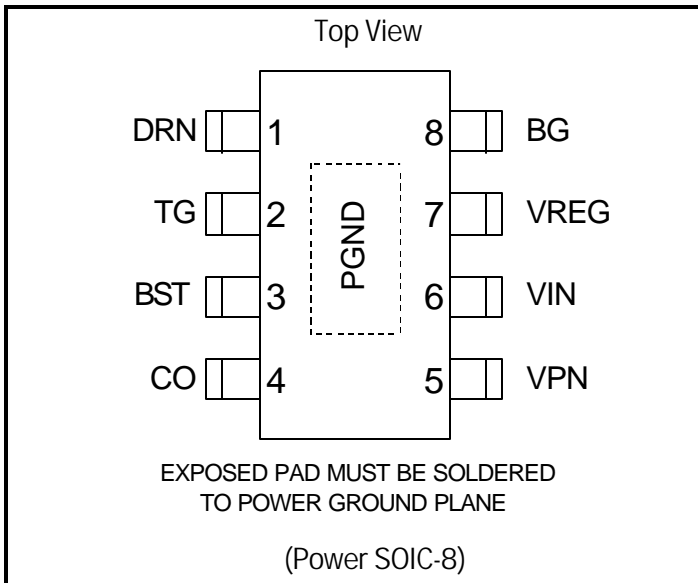

## Ordering Information

| Device <sup>(1)</sup> | Package  | Temp Range (T <sub>J</sub> ) |
|-----------------------|----------|------------------------------|
| SC1211STR             | EDP SO-8 | 0° to 125°C                  |

Note:

(1) Only available in tape and reel packaging. A reel contains 2500 devices.

## Pin Descriptions

| Pin # | Pin Name | Pin Function                                                                                                                                                                               |
|-------|----------|--------------------------------------------------------------------------------------------------------------------------------------------------------------------------------------------|
| 1     | DRN      | The power phase node (or switching node) of the synchronous buck converter. This pin can be subjected to a negative spike up to $-V_{REG}$ relative to PGND without affecting operation.   |
| 2     | TG       | Output gate drive for the switching (top) MOSFET.                                                                                                                                          |
| 3     | BST      | Bootstrap pin. A capacitor is connected between BST and DRN pins to develop the floating bootstrap voltage for the high-side MOSFET. The capacitor value is typically 1 $\mu$ F (ceramic). |
| 4     | CO       | Logic level PWM input signal to the SC1211 supplied by external controller. An internal 50kohm resistor is connected from this pin to PGND.                                                |
| 5     | VPN      | Virtual Phase Node. Connect an RC between this pin and the output sense point to Enable Combi-Sense™ operation. See the Typical Application Circuit.                                       |
| 6     | VIN      | Supply power for LDO and the internal Combi-Sense™ circuitry. Connect to input power rail of the converter.                                                                                |
| 7     | VREG     | LDO output. Decouple with 1 $\mu$ F to 4.7 $\mu$ F (ceramic) with lead length no more than 0.2" (5mm).                                                                                     |
| 8     | BG       | Output gate drive for the synchronous (bottom) MOSFET.                                                                                                                                     |
| PAD   | PGND     | Ground. Keep this pin close to the synchronous MOSFETs source.                                                                                                                             |

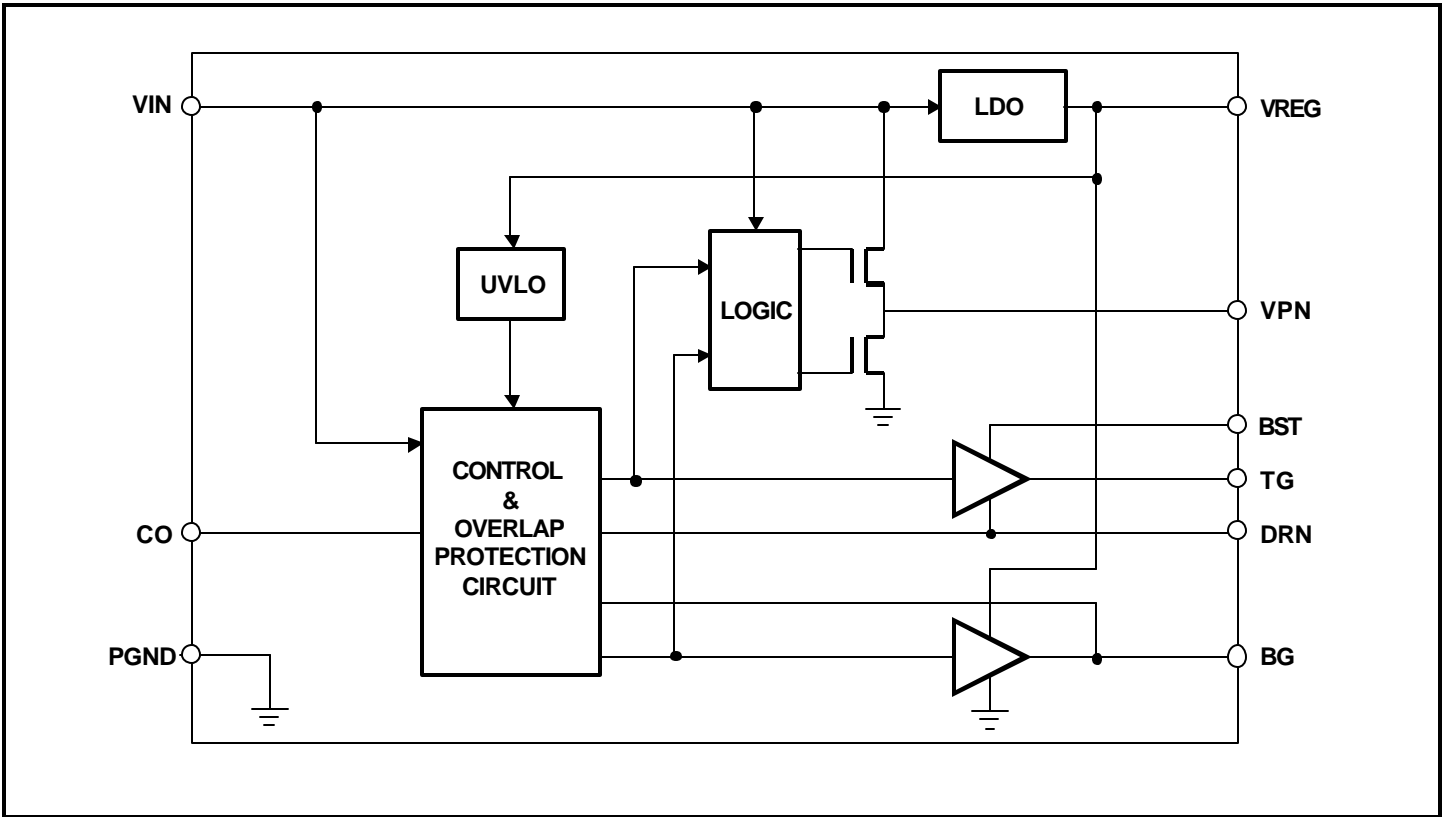
**POWER MANAGEMENT**
**Block Diagram**

## POWER MANAGEMENT

## Applications Information

## THEORY OF OPERATION

The SC1211 is a high speed, Combi-Sense™, dual output driver designed to drive top and bottom MOSFETs in a synchronous Buck converter. It features adaptive delay for shoot-through protection and VID-on-Fly operation; internal LDO for optimum gate drive voltage; and Virtual Phase Node for Combi-Sense™ solution. These drivers combined with PWM controller SC2643VX form a multi-phase voltage regulator for advanced microprocessors. A three-phase voltage regulator with 12V input 60A output is shown in the Typical Application Circuit section.

## Startup and UVLO

To startup the driver, a supply voltage is applied to VIN pin of the SC1211. The top and bottom gates are held low until VIN exceeds UVLO threshold of the driver, typically 4.0V. Then the top gate remains low and the bottom gate is pulled high to turn on the bottom FET. Once VIN exceeds UVLO threshold of the PWM controller, typically 7.5V, the soft-start begins and the PWM signal takes fully control of the gate transitions.

## Gate Transition and Shoot through Protection

Refer to the Timing Diagrams section, the rising edge of the PWM input initiates the bottom FET turn-off and the top FET turn-on. After a short propagation delay ( $t_{PDL\_BG}$ ), the bottom gate begins to fall ( $t_{F\_BG}$ ). An adaptive circuit in the SC1211 monitors the bottom gate voltage to drop below 1.4V. Then after a preset delay time ( $t_{PDH\_TG}$ ) is expired, the top gate turns on. The delay time is set to be 20ns typically. This prevents the top FET from turning on until the bottom FET is off. During the transition, the inductor current is freewheeling through the body diode of either bottom FET or top FET, upon the direction of the inductor current. The phase node could be low (ground) or high (VIN).

The falling edge of the PWM input controls the top FET turn-off and the bottom FET turn-on. After a short propagation delay ( $t_{PDL\_TG}$ ), the top gate begins to fall ( $t_{F\_TG}$ ). As the inductor current is commutated from the top FET to the body diode of the bottom FET, the phase node begins to fall. The adaptive circuit in the SC1211 detects the phase node voltage. It holds the bottom FET off until the phase node voltage has dropped below 1.0V. This prevents the top and bottom FETs from conducting

simultaneously or shoot-through.

## VID-on-Fly Operation

Certain new processors have required to changing the VID dynamically during the operation, or referred as VID-on-Fly operation. A VID-on-Fly can occur under light load or heavy load conditions. At light load, it could force the converter to sink current. Upon turn-off of the top FET, the reversed inductor current has to be freewheeling through the body diode of the top FET instead of the bottom FET. As a result, the phase node voltage remains high. The SC1211 incorporates the ability by pulling the bottom gate to high internally, which over rides the adaptive circuit and turns the bottom FET on. The delay time from the PWM falling edge to the bottom gate turn-on is set at 200ns typically.

## Virtual Phase Node for Combi-Sense™

Peak-Current-Mode control is widely employed in multi-phase voltage regulators. It features phase current balance, fast transient response, and over current protection, etc. These are essential to low-voltage high-current regulators designed for advanced microprocessors. Usually, a costly current sensing resistor is required to obtain the output inductor current information for the peak current control. The Combi-Sense™ technique featured by the SC1211 is an approach to sense inductor current without using sensing resistor.

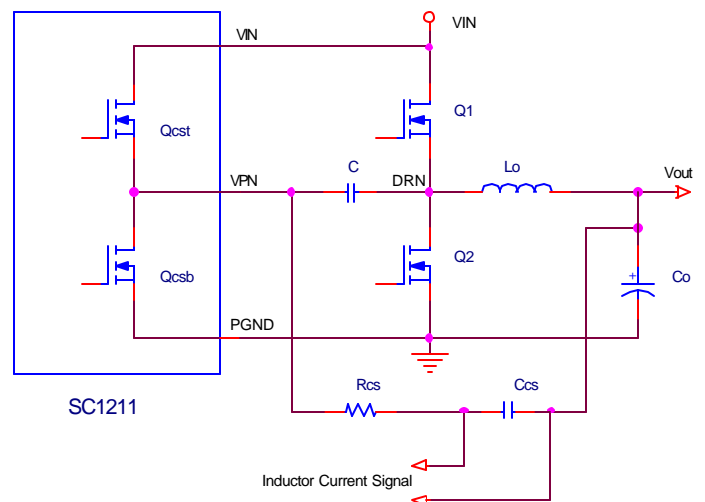

The above circuit shows the concept of Combi-Sense™ technique. An internal totem pole (Qcst, Qcsb) generates a VPN (Virtual Phase Node) signal. This VPN follows



## POWER MANAGEMENT

### Applications Information (Cont.)

the DRN (or the Power Phase Node) with the same timing. A RC network ( $R_{cs}$  and  $C_{cs}$ ) is connected between VPN and  $V_{out}$ . During Q1 turn-on,  $Q_{cst}$  turns on as well. The voltage drop across Q1 and  $L_o$  charges  $C_{cs}$ . During Q2 turn-on,  $Q_{csb}$  turns on as well. The voltage drop across Q2 and  $L_o$  discharges  $C_{cs}$ . Both voltage drops are proportional to the inductor current and a resistance equal to FET's  $R_{dson}$  plus ESR of the inductor. If the time constant  $R_{cs} \times C_{cs}$  is close to the  $L_o/R_o$  of the inductor, where  $R_o$  is given by

$$R_o = R_{inductor} + R_{dson\_hs} * D + R_{dson\_ls} * (1 - D)$$

the signal developed across  $C_{cs}$  will be proportional to the inductor current, where  $R_o$  is the equivalent current sensing resistance. In the above equation,  $R_{inductor}$  is ESR of the inductor,  $R_{dson\_hs}$  and  $R_{dson\_ls}$  are the top and bottom FET's  $R_{dson}$ , and  $D$  is the duty cycle of the converter.

Since a perfect timing match down to the nanosecond is impossible, the VPN totem pole is held in tri-state during the commutations of DRN in the SC1211. This avoids errors and offset on the current detection which can be significant since the timing mismatch is multiplied by the input voltage. An optional capacitor between VPN and DRN allows these two nodes to be AC coupled during the tri-state window, hence yields a perfect timing match. Refer to Semtech SC2643VX Combi-Sense™ Current Mode Controller about the details of the Combi-Sense technique.

### Optimized Gate Drive Voltage

With the supply voltage in between 9V to 16V, an internal LDO is designed with the SC1211 to bring the voltage to a lower level for gate drive. An external Ceramic capacitor (1uF to 4.7uF) connected in between  $V_{reg}$  to ground is needed to support the LDO. The LDO output is connected to low gate drive internally, and has to be connected to high gate drive through an external bootstrap circuit. The LDO output voltage is set at 8.5V. The manufacture data and bench tested results show that, for low  $R_{dson}$  FETs run at applied load current, the optimum gate drive voltage is around 8.5V, where the total power losses of power FETs, including conduction loss and switching loss, are minimized.

### Thermal Shut Down

The SC1211 will shut down by pulling both driver outputs low if its junction temperature,  $T_j$ , exceeds 155°C.

## COMPONENT SELECTION

### Switching Frequency, Inductor and MOSFETs

The SC1211 is capable of providing up to 3.5A peak drive current, and operating up to 1.5MHz PWM frequency without causing thermal stress on the driver. The selection of switching frequency, together with inductor and FETs is a trade-off between the cost, size, and thermal management of a multi-phase voltage regulator. In modern microprocessor applications, these parameters could be in the range of:

|                     |                                                                 |
|---------------------|-----------------------------------------------------------------|
| Switching Frequency | 100kHz to 500kHz per phase                                      |
| Inductor Value      | 0.2uH to 2uH                                                    |
| FETs                | 4m-ohm to 20m-ohm $R_{dson}$<br>20nC to 100nC total gate charge |

### Bootstrap Circuit

The SC1211 uses an external bootstrap circuit to provide a voltage for the top FET drive. This voltage, referring to the Phase Node, is held up by a bootstrap capacitor. The capacitor value can be calculated based on the total gate charge of the top FET,  $Q_{TOP}$ , and an allowed voltage ripple on the capacitor,  $\Delta V_{BST}$ , in one PWM cycle:

$$C_{BST} > Q_{TOP} / \Delta V_{BST}$$

Typically, it is recommended to use a 1uF ceramic capacitor with 25V rating and a commonly available diode IN4148 for the bootstrap circuit. In addition, a small resistor (one ohm) has to be added in between DRN of the SC1211 and the Phase Node. The resistor is used to alleviate the stress of the SC1211 from exposing to the negative spike at the Phase node. A negative spike could occur at the Phase Node during the top FET turn-off due to parasitic inductance in the switching loop. The spike could be minimized with a careful PCB layout. In those applications with TO-220 package FETs, it is recommended to use a clamping diode on the DRN pin to mitigate the impact of the excessive phase node negative spike.

**POWER MANAGEMENT**

**Applications Information (Cont.)**

**Filters for Supply Power**

For VREG pin of the SC1211, it is recommended to use a 1uF to 4.7uF, 25V rating ceramic capacitor for decoupling.

**LAYOUT GUIDELINES**

The switching regulator is a high di/dt power circuit. Its Printed Circuit Board (PCB) layout is critical. A good layout can achieve an optimum circuit performance while minimized the component stress, resulting in better system reliability. For a multi-phase voltage regulator, the SC1211 driver, FETs, inductor, and supply decoupling capacitors in each phase have to be considered as a whole during PCB layout. Refer to Semtech SC2643VX/SC1211 EVB Layout Guideline.

For the SC1211 driver, the following guidelines are typically recommended during PCB layout:

1. Place the SC1211 close to the FETs for shortest gate drive traces and ground return paths.
2. Connect bypass capacitors as close as possible to decoupling pins (VREG and VIN) and PGND. The trace length of the decoupling capacitor on VREG pin should be no more than 0.2" (5mm).
3. Locate the components of the bootstrap circuit close to the SC1211.

**SOLDERING CONSIDERATION**

The exposed die pad of the SC1211 is used for ground

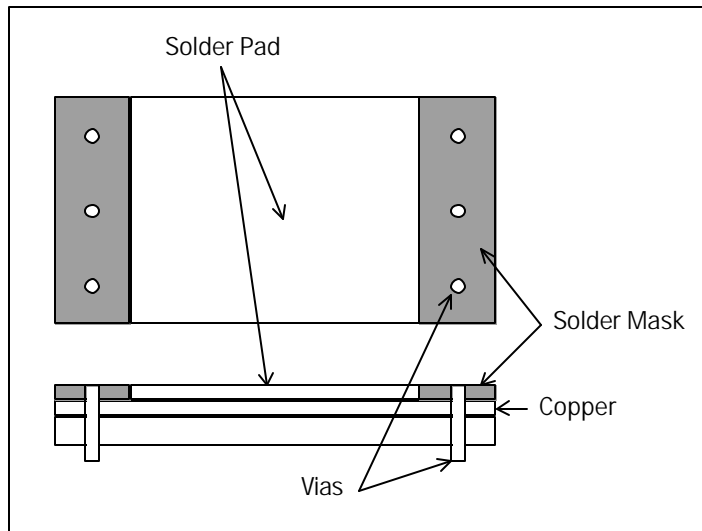

return and thermal release of the driver. The pad must be soldered to the ground plane that is further connected to the system ground in the inner layer through multiple vias. For better electrical and thermal performance, it is recommended to use all copper available under the driver as the ground plane, and place the vias as close as possible to the solder pad. Meanwhile, the vias have to be masked out to prevent solder leakage during reflow. The layout arrangement is detailed in the above figure, which also can be found in the "Land Pattern – Power SOIC-8" section.

POWER MANAGEMENT

Outline Drawing - Power SOIC-8L

| DIM <sup>N</sup> | INCHES   |      | MM       |      | NOTE |
|------------------|----------|------|----------|------|------|
|                  | MIN      | MAX  | MIN      | MAX  |      |
| A                | .189     | .195 | 4.80     | 4.95 | 2    |
| B                | .152     | .157 | 3.86     | 4.00 | 3    |
| C                | .230     | .244 | 5.84     | 6.20 |      |
| D                | .050 BSC |      | 1.27 BSC |      |      |
| E                | .014     | .020 | 0.35     | 0.51 |      |
| F                | .001     | .005 | .025     | .127 |      |
| H                | .056     | .066 | 1.42     | 1.68 |      |
| J                | .010     | .016 | 0.25     | 0.41 |      |
| K                | .007     | .010 | 0.19     | 0.25 |      |
| L                | 0°       | 8°   | 0°       | 8°   |      |
| M                | .016     | .035 | 0.41     | 0.89 |      |
| N                | .091     | .099 | 2.31     | 2.51 | 4    |
| P                | .116     | .124 | 2.95     | 3.15 | 4    |

- 1 END USER SHOULD VERIFY ACTUAL SIZE OF EXPOSED THERMAL DIE PAD FOR SPECIFIC DEVICE APPLICATION
- 2 DIMENSION "B" DOES NOT INCLUDE INTER-LEAD FLASH OR PROTUSIONS INTER-LEAD FLASH AND PROTUSIONS SHALL NOT EXCEED .25 mm (.010") PER SIDE.
- 3 DIMENSION "A" DOES NOT INCLUDE MOLD FLASH, PROTUSIONS OR GATE BURRS. MOLD FLASH, PROTUSIONS AND GATE BURRS SHALL NOT EXCEED .15 mm (.010") PER SIDE
- 4 CONTROLLING DIMENSION : MILLIMETER

Land Pattern - Power SOIC-8

| DIM <sup>N</sup> | INCHES   |      | MM       |      | NOTE |
|------------------|----------|------|----------|------|------|
|                  | MIN      | MAX  | MIN      | MAX  |      |
| A                | .050 BSC |      | 1.27 BSC |      |      |
| B                | .025     | .030 | .64      | .76  |      |
| C                | .095     | .010 | 2.41     | 2.54 |      |
| D                | .310     | .320 | 7.87     | 8.13 |      |
| E                | .200     | .210 | 5.08     | 5.33 |      |
| F                | .130     | .135 | 3.30     | 3.43 |      |
| H                | .070     | .075 | 1.78     | 1.91 |      |

Contact Information

Semtech Corporation  
 Power Management Products Division  
 200 Flynn Rd., Camarillo, CA 93012  
 Phone: (805)498-2111 FAX (805)498-3804