

Description

The μPD7227 intelligent dot-matrix LCD controller/driver is a peripheral device designed to interface most microprocessors with a wide variety of dot matrix LCDs. It can directly drive any multiplexed LCD organized as 8 rows by 40 columns, and is easily cascaded up to 16 rows and 280 columns. The μPD7227 is equipped with several hardware logic blocks, such as an 8-bit serial interface, ASCII character generator, 40 x 16 static RAM with full read/write capability, and an LCD timing controller; all of which reduce microprocessor system software requirements. The μPD7227 is manufactured with a single 5 V CMOS process, and is available in a space-saving 64-pin plastic flat package.

Features

- Single-chip LCD controller with direct LCD drive
- Compatible with most microprocessors
- Eight row drives
 - Designed for dot-matrix LCD configurations up to 280 dots
 - Designed for 5 x 7 dot-matrix character LCD configuration up to 8 characters
 - Cascadable to 16 row drives
- 40 column drives
 - Cascadable to 280 column drives
- Hardware logic blocks reduce system software requirements
 - 8-bit serial interface for communication
 - ASCII 5 x 7 dot-matrix character generator with 64-character vocabulary
 - 40 x 16-bit static RAM for data storage, retrieval, and complete back-up memory capability.
 - Voltage controller generates LCD bias voltages
 - Timing controller synchronizes column drives with sequentially-multiplexed row drives
- Single +5 V power supply
- CMOS technology

Ordering Information

Part Number	Package Type	Max Frequency of Operation
μPD7227G-12	64-pin plastic QFP	1000 kHz

Pin Configuration

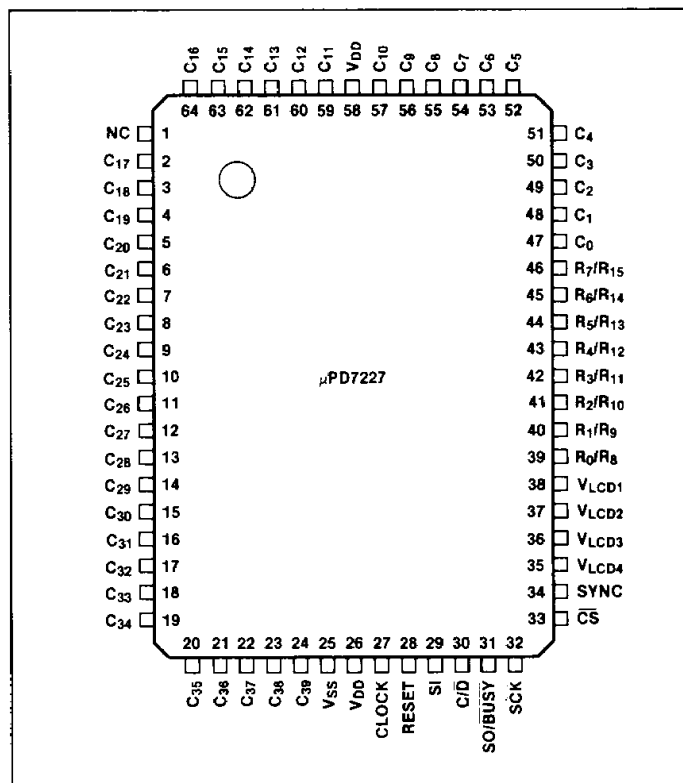

Pin Identification

No.	Symbol	Function
1	NC	No connection
2-24, 47-57, 59-64	C ₀ -C ₃₉	LCD column driver outputs
25	V _{SS}	Ground
26, 58	V _{DD}	Power
27	CLOCK	System clock input
28	RESET	Reset input
29	SI	Serial input
30	C/D	Command or data select input
31	SO/BUSY	Serial output or busy output
32	SCK	Serial clock input
33	CS	Chip select input
34	SYNC	Synchronization port
35-38	V _{LCD1} -V _{LCD4}	LCD bias voltage supply inputs
39-46	R ₀ /R ₈ -R ₇ /R ₁₅	LCD row driver outputs

Pin Functions

C₀-C₃₉

LCD column driver outputs.

R₀/8-R₇/15

LCD row driver outputs.

V_{LCD1}-V_{LCD4}

LCD bias voltage supply inputs to the LCD voltage controller. Apply appropriate voltages from a voltage ladder connected across VDD.

SI

Serial input from the microprocessor.

SO/BUSY****

Serial output from the μPD7227 to the microprocessor when in read mode and C/D is low. When **BUSY** (active low), handshake output indicates the μPD7227 is ready to receive/send the next data byte.

SCK

Serial clock input. Synchronizes 8-bit serial data transfer between the microprocessor and μPD7227.

C/D

Command/data select input. Distinguishes serially input data byte as a command or as display data.

CS

Chip select input. Enables the μPD7227 for communication with the microprocessor.

SYNC

Synchronization port. For multichip operation, tie all SYNC lines together and configure with the MODE SET command.

CLOCK

System clock input. Connect to external clock source.

RESET

Reset input. RC circuit or pulse initializes the μPD7227 after power-up.

V_{DD}

Power supply positive. Apply single voltage 5 V ± 10% for proper operation.

V_{SS}

Ground.

Block Diagram

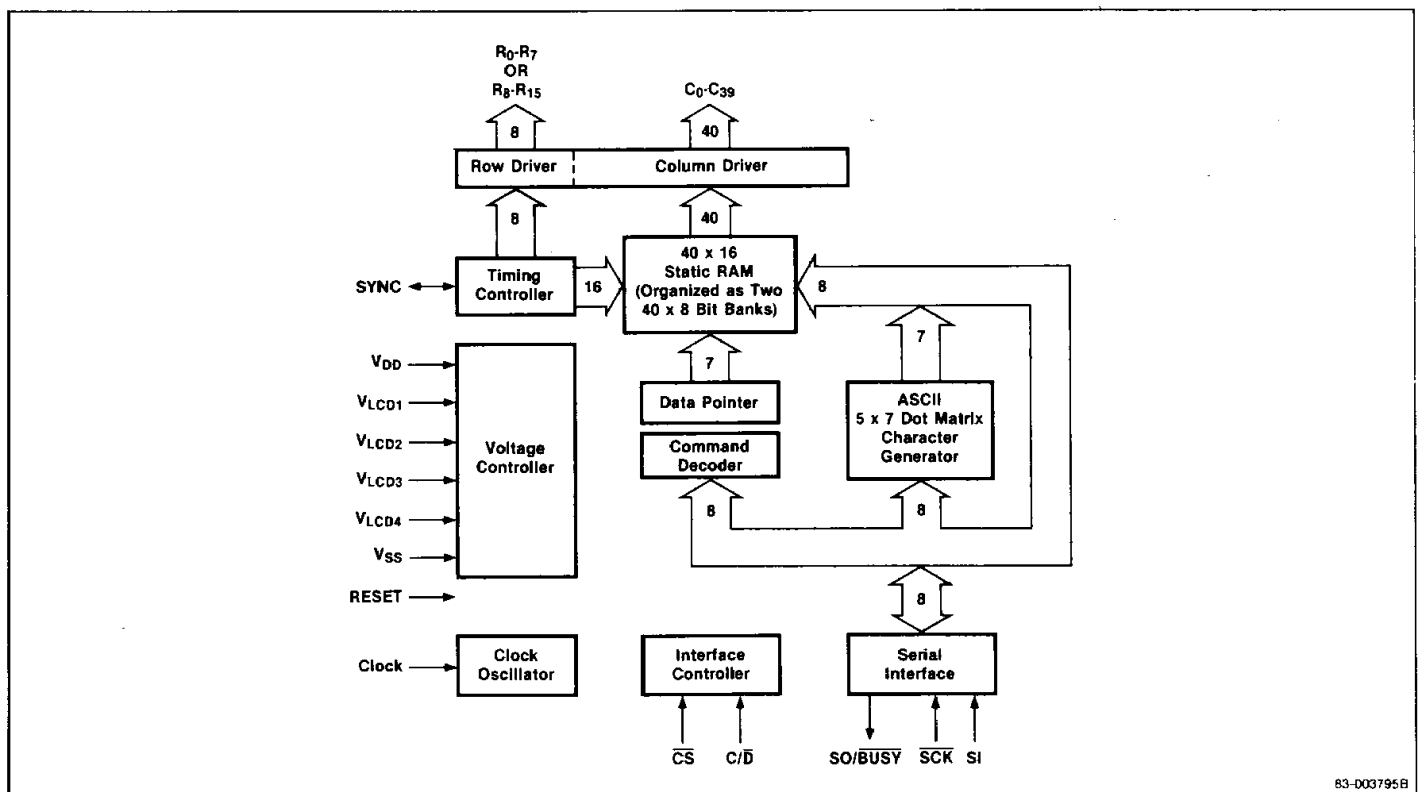

83-003795B

Absolute Maximum Ratings

T_A = 25°C

Power supply, V _{DD}	-0.3 V to +7.0 V
All inputs and outputs with respect to V _{CC}	-0.3 V to V _{DD} +0.3 V
Storage temperature, T _{STG}	-65°C to +150°C
Operating temperature, T _{OPT}	-10°C to +70°C

Comment: Exposing the device to stresses above those listed in Absolute Maximum Ratings could cause permanent damage. The device is not meant to be operated under conditions outside the limits described in the operational sections of this specification. Exposure to absolute maximum rating conditions for extended periods may affect device reliability.

Capacitance

T_A = 25°C, V_{DD} = 0V

Parameter	Symbol	Limits		Unit	Test Conditions
		Min	Max		
Input capacitance	C _I		10	pF	f _φ = 1 MHz
Output capacitance	C _O		25	pF	Unmeasured pins returned to ground.
Input/output capacitance	C _{IO}		15	pF	SYNC

DC Characteristics

T_A = -10°C to +70°C, V_{DD} = +5.0V ± 10%

Parameter	Symbol	Limits			Unit	Test Conditions
		Min	Typ	Max		
Input voltage, high	V _{IH}	0.7 V _{DD}		V _{DD}	V	
Input voltage, low	V _{IL}	0		0.3 V _{DD}	V	
Input leakage current, high	I _{LIH}			+10	μA	V _{IH} = V _{DD}
Input leakage current, low	I _{LIL}			-10	μA	V _{IH} = 0V
Output voltage, high	V _{OH1}	V _{DD} -0.5			V	SO/BUSY, I _{OH} = -400 μA
	V _{OH2}	V _{DD} -0.5			V	SYNC, I _{OH} = -100 μA
Output voltage, low	V _{OL1}			0.45	V	SO/BUSY, I _{OL} = +1.7 mA
				0.45	V	SYNC, I _{OL} = +100 μA
Output leakage current, high	I _{LOH}			+10	μA	V _{OH} = V _{DD}
Output leakage current, low	I _{LOL}			-10	μA	V _{OL} = 0V
LCD operating voltage	V _{LCD}	3.0		V _{DD}	V	8-row multiplexed LCD drive configuration
				V _{DD}	V	16-row multiplexed LCD drive configuration
Row drive output impedance	R _{ROW}		4	8	kΩ	
Column drive output impedance	R _{COLUMN}		10	15	kΩ	
Supply current	I _{DD}		200	400	μA	f _D = 400 KHz

AC Characteristics

T_A = -10°C to +70°C, V_{DD} = +5.0V ± 10%

Parameter	Symbol	Limits		Unit	Test Conditions
		Min	Max		
Clock frequency	f _φ	100	1000	KHz	
Clock pulse width high	t _{φWH}	400		ns	
Clock pulse width low	t _{φWL}	400		ns	
SCK cycle	t _{CYK}	0.9		μs	
SCK pulse width high	t _{KWH}	400		ns	
SCK pulse width low	t _{KWL}	400		ns	
SCK hold time after $\overline{\text{BUSY}}\uparrow$	t _{KHB}	0		ns	
SI setup time to SCK \uparrow	t _{ISK}	100		ns	
SI hold time after SCK \uparrow	t _{IHK}	250		ns	
SO delay time after SCK \downarrow	t _{ODK}		320	ns	C _{LOAD} = 50 pF
SO delay time after C/ $\overline{\text{D}}\downarrow$	t _{ODD}		2	μs	
SCK hold time after C/ $\overline{\text{D}}\downarrow$	t _{KHD}	2		μs	
$\overline{\text{BUSY}}$ delay time after 8th SCK \uparrow	t _{BDK}		3	μs	C _{LOAD} = 50 pF
$\overline{\text{BUSY}}$ delay time after C/ $\overline{\text{D}}\uparrow$	t _{BDD}		2	μs	
$\overline{\text{BUSY}}$ delay time after $\overline{\text{CS}}\downarrow$	t _{BDC}		2	μs	
C/ $\overline{\text{D}}$ setup time to 8th SCK \uparrow	t _{DSK}	2		μs	
C/ $\overline{\text{D}}$ hold time after 8th SCK \uparrow	t _{DHK}	2		μs	
$\overline{\text{CS}}$ hold time after 8th SCK \uparrow	t _{CHK}	2		μs	
$\overline{\text{CS}}$ pulse width high	t _{CWH}	2/f _φ		μs	
$\overline{\text{CS}}\uparrow$ delay time to $\overline{\text{BUSY}}$ floating	t _{CDB}	2		μs	C _{LOAD} = 50 pF
SYNC load capacitance	C _{LOADS}		100	pF	
$\overline{\text{BUSY}}$ low level width	t _{WLB}	18	64	1/f _φ	C _{LOAD} = 50 pF

Timing Waveforms

Clock Waveform

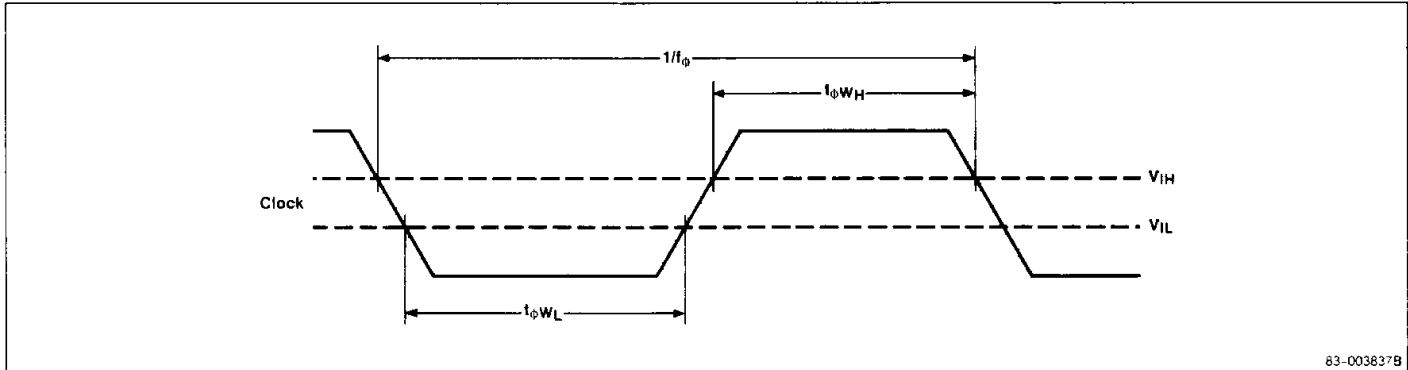

83-003837B

Serial Interface

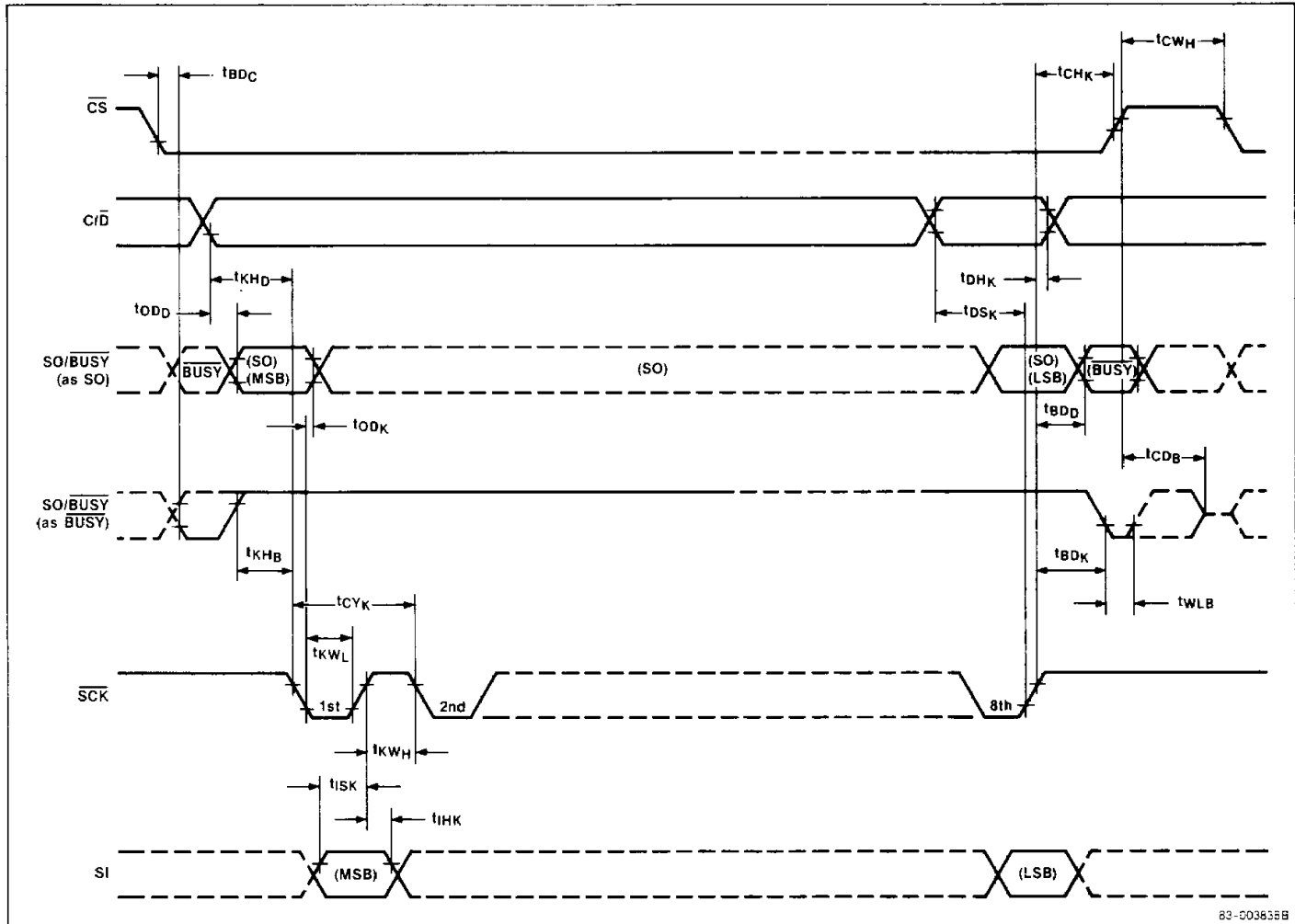

83-003838B

Command Summary

Command	Description	Instruction Code								HEX
		Binary								
		D ₇	D ₆	D ₅	D ₄	D ₃	D ₂	D ₁	D ₀	
Mode Set	Initialize the μPD7227, including selection of 1. LCD drive configuration 2. Row driver port function 3. RAM bank 4. SYNC port function	0	0	0	1	1	D ₂	D ₁	D ₀	18-1F
Frame Frequency Set	Set LCD frame frequency	0	0	0	1	0	D ₂	D ₁	D ₀	10-14
Load Data Pointer	Load data pointer with 7 bits of immediate data	1	D ₆	D ₅	D ₄	D ₃	D ₂	D ₁	D ₀	80-E7
Write Mode	Write display byte in serial register to RAM location addressed by data pointer; modify data pointer	0	1	1	0	0	1	D ₁	D ₀	64-67
Read Mode	Load RAM contents addressed by data pointer into serial register for output; modify data pointer	0	1	1	0	0	0	D ₁	D ₀	60-63
AND Mode	Perform a logical AND between the display byte in the serial register and the RAM contents addressed by data pointer; write result to same RAM location; modify data pointer	0	1	1	0	1	1	D ₁	D ₀	6C-6F
OR Mode	Perform a logical OR between the display byte in the serial register and the RAM contents addressed by data pointer; write result to same RAM location; modify data pointer	0	1	1	0	1	0	D ₁	D ₀	68-6B
Character Mode	Decode display byte in serial register into 5 x 7 character with character generator; write character to RAM location addressed by data pointer; increment data pointer by 5	0	1	1	1	0	0	1	0	72
Set Bit	Set single bit of RAM location addressed by data pointer; modify data pointer	0	1	0	D ₄	D ₃	D ₂	D ₁	D ₀	40-5F
Reset Bit	Reset single bit of RAM location addressed by data pointer; modify data pointer	0	0	1	D ₄	D ₃	D ₂	D ₁	D ₀	20-3F
Enable Display	Turn on the LCD	0	0	0	0	1	0	0	1	09
Disable Display	Turn off the LCD	0	0	0	0	1	0	0	0	08

Further details of operation can be found in the μPD7227 intelligent dot-matrix LCD controller/driver technical manual.

5x7 Character Set as Generated in μPD7227

Display Byte								0	0	1	1
D7	D6	D5	D4	D3	D2	D1	D0	1	1	0	0
				0	0	0	0				
				0	0	0	1				
				0	0	1	0				
				0	0	1	1				
				0	1	0	0				
				0	1	0	1				
				0	1	1	0				
				0	1	1	1				

Display Byte								0	0	1	1
D7	D6	D5	D4	D3	D2	D1	D0	1	1	0	0
				1	0	0	0				
				1	0	0	1				
				1	0	1	0				
				1	0	1	1				
				1	1	0	0				
				1	1	0	1				
				1	1	1	0				
				1	1	1	1				