

**256K-BIT CMOS STATIC RAM
32K-WORD BY 8-BIT**

Description

The μ PD43256B is a high speed, low power, and 262,144 bits (32,768 words by 8 bits) CMOS static RAM.

Battery backup is available. And A and B versions are wide voltage operations.

The μ PD43256B is packed in 28-pin PLASTIC DIP, 28-pin PLASTIC SOP and 28-pin PLASTIC TSOP (I) (8 x 13.4 mm).

Features

- 32,768 words by 8 bits organization
- Fast access time: 70, 85, 100, 120, 150 ns (MAX.)
- Low voltage operation (A version: $V_{CC} = 3.0$ to 5.5 V, B version: $V_{CC} = 2.7$ to 5.5 V)
- Low V_{CC} data retention: 2.0 V (MIN.)
- /OE input for easy application

Part number	Access time ns (MAX.)	Operating supply voltage V	Operating ambient temperature °C	Supply current		
				At operating mA (MAX.)	At standby μ A (MAX.)	At data retention μ A (MAX.) ^{Note1}
μ PD43256B-xxL	70, 85	4.5 to 5.5	0 to 70	45	50	3
μ PD43256B-xxLL					15	2
μ PD43256B-Axx	85, 100 ^{Note2} , 120 ^{Note2}	3.0 to 5.5				
μ PD43256B-Bxx ^{Note2}	100, 120, 150	2.7 to 5.5				

Notes 1. $T_A \leq 40$ °C, $V_{CC} = 3.0$ V

2. Access time: 85 ns (MAX.) ($V_{CC} = 4.5$ to 5.5 V)

The information in this document is subject to change without notice. Before using this document, please confirm that this is the latest version.

Not all products and/or types are available in every country. Please check with an NEC Electronics sales representative for availability and additional information.

Ordering Information

(1/2)

Part number	Package	Access time ns (MAX.)	Operating supply voltage V	Operating ambient temperature °C	Remark	
μPD43256BCZ-70L	28-pin PLASTIC DIP (15.24 mm (600))	70	4.5 to 5.5	0 to 70	L version	
μPD43256BCZ-85L		85				
μPD43256BCZ-70LL		70			LL version	
μPD43256BCZ-85LL		85				
μPD43256BGU-70L	28-pin PLASTIC SOP (11.43 mm (450))	70	4.5 to 5.5	0 to 70	L version	
μPD43256BGU-85L		85				
μPD43256BGU-70LL		70			LL version	
μPD43256BGU-85LL		85				
μPD43256BGU-A85		85	3.0 to 5.5	0 to 70	A version	
μPD43256BGU-A10		100				
μPD43256BGU-A12		120				
μPD43256BGU-B10		100	2.7 to 5.5	0 to 70	B version	
μPD43256BGU-B12		120				
μPD43256BGW-70LL-9JL		28-pin PLASTIC TSOP (I) (8x13.4) (Normal bent)	70	4.5 to 5.5	0 to 70	LL version
μPD43256BGW-85LL-9JL			85			
μPD43256BGW-A85-9JL			85	3.0 to 5.5	0 to 70	A version
μPD43256BGW-A10-9JL	100					
μPD43256BGW-A12-9JL	120					
μPD43256BGW-B10-9JL	100		2.7 to 5.5	0 to 70	B version	
μPD43256BGW-B12-9JL	120					
μPD43256BGW-B15-9JL	150					
μPD43256BGW-70LL-9KL	28-pin PLASTIC TSOP (I) (8x13.4) (Reverse bent)	70	4.5 to 5.5	0 to 70	LL version	
μPD43256BGW-85LL-9KL		85				
μPD43256BGW-A85-9KL		85	3.0 to 5.5	0 to 70	A version	
μPD43256BGW-A10-9KL		100				
μPD43256BGW-A12-9KL		120				
μPD43256BGW-B10-9KL		100	2.7 to 5.5	0 to 70	B version	
μPD43256BGW-B12-9KL		120				
μPD43256BGW-B15-9KL		150				

(2/2)

Part number	Package	Access time ns (MAX.)	Operating supply voltage V	Operating ambient temperature °C	Remark
μPD43256BGU-70L-A	28-pin PLASTIC SOP (11.43 mm (450))	70	4.5 to 5.5	0 to 70	L version
μPD43256BGU-85L-A		85			
μPD43256BGU-70LL-A		70			LL version
μPD43256BGU-85LL-A		85			
μPD43256BGU-A85-A		85	3.0 to 5.5		A version
μPD43256BGU-A10-A		100			
μPD43256BGU-A12-A		120			
μPD43256BGU-B10-A		100	2.7 to 5.5		B version
μPD43256BGU-B12-A		120			
μPD43256BGW-70LL-9JL-A	28-pin PLASTIC TSOP (I) (8x13.4) (Normal bent)	70	4.5 to 5.5	0 to 70	LL version
μPD43256BGW-85LL-9JL-A		85			
μPD43256BGW-A85-9JL-A		85	3.0 to 5.5		A version
μPD43256BGW-A10-9JL-A		100			
μPD43256BGW-A12-9JL-A		120			
μPD43256BGW-B10-9JL-A		100	2.7 to 5.5		B version
μPD43256BGW-B12-9JL-A		120			
μPD43256BGW-B15-9JL-A		150			
μPD43256BGW-70LL-9KL-A		28-pin PLASTIC TSOP (I) (8x13.4) (Reverse bent)	70		4.5 to 5.5
μPD43256BGW-85LL-9KL-A	85				
μPD43256BGW-A85-9KL-A	85		3.0 to 5.5	A version	
μPD43256BGW-A10-9KL-A	100				
μPD43256BGW-A12-9KL-A	120				
μPD43256BGW-B10-9KL-A	100		2.7 to 5.5	B version	
μPD43256BGW-B12-9KL-A	120				
μPD43256BGW-B15-9KL-A	150				

Remark Products with -A at the end of the part number are lead-free products.

Pin Configurations (Marking Side)

/xxx indicates active low signal.

28-pin PLASTIC DIP (15.24 mm (600))

[μPD43256BCZ-xxL]

[μPD43256BCZ-xxLL]

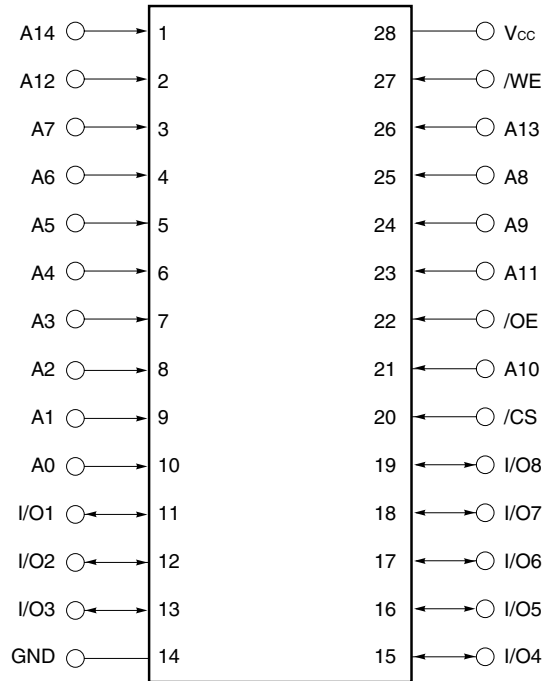

- A0 - A14 : Address inputs
- I/O1 - I/O8 : Data inputs / outputs
- /CS : Chip Select
- /WE : Write Enable
- /OE : Output Enable
- V_{CC} : Power supply
- GND : Ground

Remark Refer to **Package Drawings** for the 1-pin index mark.

28-pin PLASTIC SOP (11.43 mm (450))

[μPD43256BGU-xxL]

[μPD43256BGU-xxLL]

[μPD43256BGU-Axx]

[μPD43256BGU-Bxx]

[μPD43256BGU-xxL-A]

[μPD43256BGU-xxLL-A]

[μPD43256BGU-Axx-A]

[μPD43256BGU-Bxx-A]

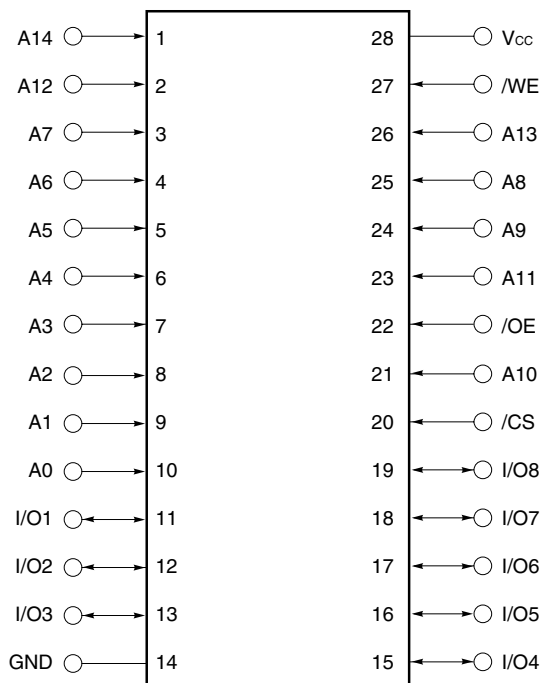

A0 - A14 : Address inputs

I/O1 - I/O8 : Data inputs / outputs

/CS : Chip Select

/WE : Write Enable

/OE : Output Enable

Vcc : Power supply

GND : Ground

Remark Refer to **Package Drawings** for the 1-pin index mark.

28-pin PLASTIC TSOP (I) (8x13.4) (Normal bent)

- [μPD43256BGW-xxLL-9JL]
- [μPD43256BGW-Axx-9JL]
- [μPD43256BGW-Bxx-9JL]
- [μPD43256BGW-xxLL-9JL-A]
- [μPD43256BGW-Axx-9JL-A]
- [μPD43256BGW-Bxx-9JL-A]



28-pin PLASTIC TSOP (I) (8x13.4) (Reverse bent)

- [μPD43256BGW-xxLL-9KL]
- [μPD43256BGW-Axx-9KL]
- [μPD43256BGW-Bxx-9KL]
- [μPD43256BGW-xxLL-9KL-A]
- [μPD43256BGW-Axx-9KL-A]
- [μPD43256BGW-Bxx-9KL-A]

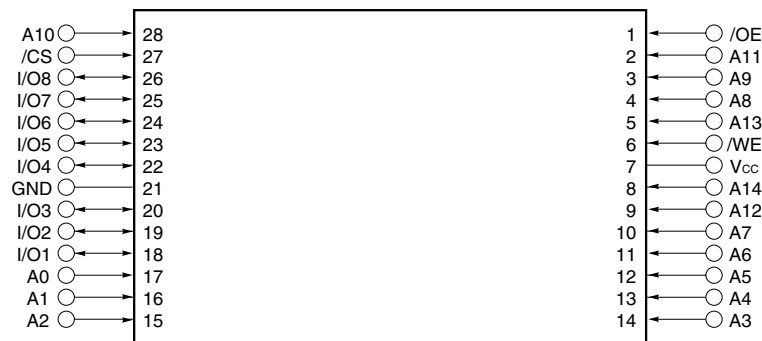

- A0 - A14 : Address inputs /OE : Output Enable
- /O1 - /O8 : Data inputs / outputs Vcc : Power supply
- /CS : Chip Select GND : Ground
- /WE : Write Enable

Remark Refer to **Package Drawings** for the 1-pin index mark.

Block Diagram

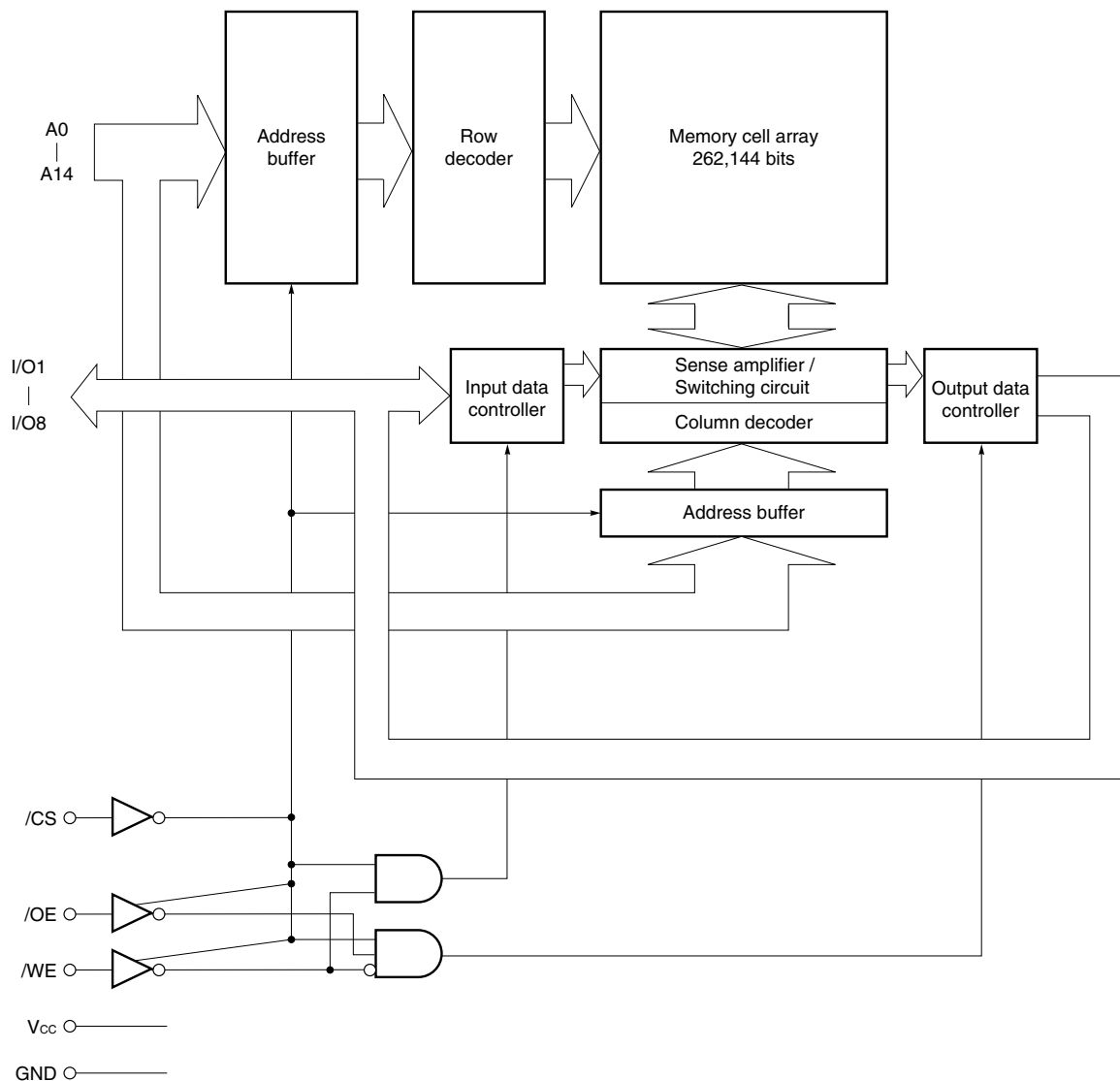

Truth Table

/CS	/OE	/WE	Mode	I/O	Supply current
H	x	x	Not selected	High impedance	I _{SB}
L	H	H	Output disable		I _{CCA}
L	x	L	Write	D _{IN}	
L	L	H	Read	D _{OUT}	

Remark x : V_{IH} or V_{IL}

Electrical Specifications

Absolute Maximum Ratings

Parameter	Symbol	Condition	Rating	Unit
Supply voltage	V _{CC}		-0.5 ^{Note} to +7.0	V
Input / Output voltage	V _T		-0.5 ^{Note} to V _{CC} + 0.5	V
Operating ambient temperature	T _A		0 to 70	°C
Storage temperature	T _{stg}		-55 to +125	°C

Note -3.0 V (MIN.) (Pulse width : 50 ns)

Caution Exposing the device to stress above those listed in Absolute Maximum Rating could cause permanent damage. The device is not meant to be operated under conditions outside the limits described in the operational section of this specification. Exposure to Absolute Maximum Rating conditions for extended periods may affect device reliability.

Recommended Operating Conditions

Parameter	Symbol	Condition	μPD43256B-xxL		μPD43256B-Axx		μPD43256B-Bxx		Unit
			μPD43256B-xxLL		MIN.	MAX.	MIN.	MAX.	
			MIN.	MAX.					
Supply voltage	V _{CC}		4.5	5.5	3.0	5.5	2.7	5.5	V
High level input voltage	V _{IH}		2.2	V _{CC} +0.5	2.2	V _{CC} +0.5	2.2	V _{CC} +0.5	V
Low level input voltage	V _{IL}		-0.3 ^{Note}	+0.8	-0.3 ^{Note}	+0.5	-0.3 ^{Note}	+0.5	V
Operating ambient temperature	T _A		0	70	0	70	0	70	°C

Note -3.0 V (MIN.) (Pulse width: 50 ns)

Capacitance (T_A = 25 °C, f = 1 MHz)

Parameter	Symbol	Test conditions	MIN.	TYP.	MAX.	Unit
Input capacitance	C _{IN}	V _{IN} = 0 V			5	pF
Input / Output capacitance	C _{I/O}	V _{I/O} = 0 V			8	pF

Remarks 1. V_{IN} : Input voltage

V_{I/O} : Input / Output voltage

2. These parameters are periodically sampled and not 100% tested.

DC Characteristics (Recommended Operating Conditions Unless Otherwise Noted) (1/2)

Parameter	Symbol	Test condition	μ PD43256B-xxL			μ PD43256B-xxLL			Unit
			MIN.	TYP.	MAX.	MIN.	TYP.	MAX.	
Input leakage current	I _{LI}	V _{IN} = 0 V to V _{CC}	-1.0		+1.0	-1.0		+1.0	μ A
I/O leakage current	I _{LO}	V _{I/O} = 0 V to V _{CC} , /OE = V _{IH} or /CS = V _{IH} or /WE = V _{IL}	-1.0		+1.0	-1.0		+1.0	μ A
Operating supply current	I _{CCA1}	/CS = V _{IL} , Minimum cycle time, I _{I/O} = 0 mA			45			45	mA
	I _{CCA2}	/CS = V _{IL} , I _{I/O} = 0 mA			10			10	
	I _{CCA3}	/CS \leq 0.2 V, Cycle = 1 MHz, I _{I/O} = 0 mA, V _{IL} \leq 0.2 V, V _{IH} \geq V _{CC} - 0.2 V			10			10	
Standby supply current	I _{SB}	/CS = V _{IH}			3			3	mA
	I _{SB1}	/CS \geq V _{CC} - 0.2 V		1.0	50		0.5	15	
High level output voltage	V _{OH1}	I _{OH} = -1.0 mA	2.4			2.4			V
	V _{OH2}	I _{OH} = -0.1 mA	V _{CC} -0.5			V _{CC} -0.5			
Low level output voltage	V _{OL}	I _{OL} = 2.1 mA			0.4			0.4	V

Remarks 1. V_{IN} : Input voltage

V_{I/O} : Input / Output voltage

2. These DC characteristics are in common regardless of package types.

DC Characteristics (Recommended Operating Conditions Unless Otherwise Noted) (2/2)

Parameter	Symbol	Test condition	μPD43256B-Axx			μPD43256B-Bxx			Unit
			MIN.	TYP.	MAX.	MIN.	TYP.	MAX.	
Input leakage current	I _{LI}	V _{IN} = 0 V to V _{CC}	-1.0		+1.0	-1.0		+1.0	μA
I/O leakage current	I _{LO}	V _{I/O} = 0 V to V _{CC} , /OE = V _{IH} or /CS = V _{IH} or /WE = V _{IL}	-1.0		+1.0	-1.0		+1.0	μA
Operating supply current	I _{CCA1}	/CS = V _{IL} , Minimum cycle time, I _{I/O} = 0 mA	μPD43256B-Axx		45			-	mA
			μPD43256B-Bxx				-	45	
			V _{CC} ≤ 3.3 V				-	20	
	I _{CCA2}	/CS = V _{IL} , I _{I/O} = 0 mA			10			10	
			V _{CC} ≤ 3.3 V				-	5	
	I _{CCA3}	/CS ≤ 0.2 V, Cycle = 1 MHz, I _{I/O} = 0 mA, V _{IL} ≤ 0.2 V, V _{IH} ≥ V _{CC} - 0.2 V			10			10	
V _{CC} ≤ 3.3 V					-	5			
Standby supply current	I _{SB}	/CS = V _{IH}			3			3	mA
			V _{CC} ≤ 3.3 V				-	2	
	I _{SB1}	/CS ≥ V _{CC} - 0.2 V			0.5	15	0.5	15	μA
			V _{CC} ≤ 3.3 V				0.5	10	
High level output voltage	V _{OH1}	I _{OH} = -1.0 mA, V _{CC} ≥ 4.5 V	2.4			2.4			V
		I _{OH} = -0.5 mA, V _{CC} < 4.5 V	2.4			2.4			
	V _{OH2}	I _{OH} = -0.02 mA	V _{CC} -0.1			V _{CC} -0.1			
Low level output voltage	V _{OL}	I _{OL} = 2.1 mA, V _{CC} ≥ 4.5 V			0.4			0.4	V
		I _{OL} = 1.0 mA, V _{CC} < 4.5 V			0.4			0.4	
	V _{OL1}	I _{OL} = 0.02 mA			0.1			0.1	

Remarks 1. V_{IN} : Input voltage

V_{I/O} : Input / Output voltage

2. These DC characteristics are in common regardless of package types.

AC Characteristics (Recommended Operating Conditions Unless Otherwise Noted)

AC Test Conditions

[μPD43256B-70L, μPD43256B-85L, μPD43256B-70LL, μPD43256B-85LL]

Input Waveform (Rise and Fall Time ≤ 5 ns)

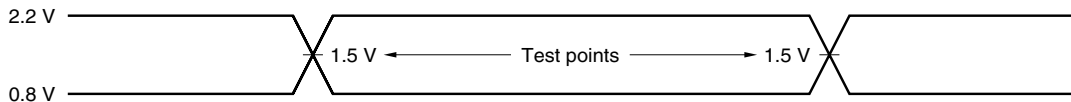

Output Waveform

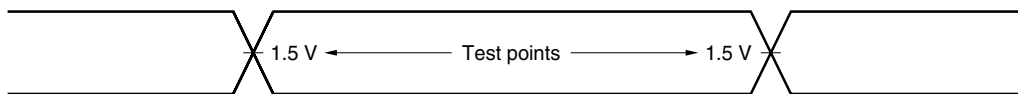

Output Load

AC characteristics should be measured with the following output load conditions.

Figure 1

(t_{AA} , t_{ACS} , t_{OE} , t_{OH})

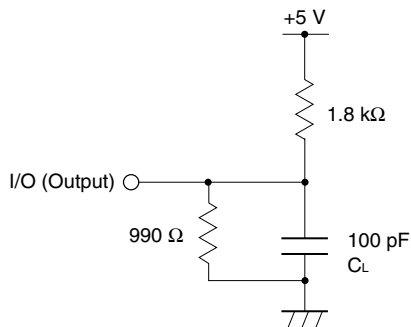
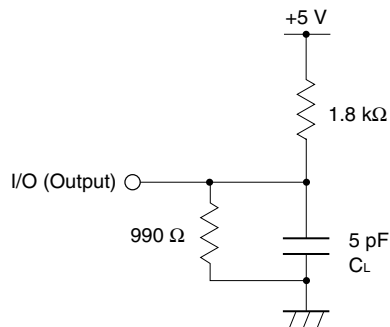

Figure 2

(t_{CHZ} , t_{CLZ} , t_{OHZ} , t_{OLZ} , t_{WHZ} , t_{OW})



Remark CL includes capacitance of the probe and jig, and stray capacitance.

[μPD43256B-A85, μPD43256B-A10, μPD43256B-A12, μPD43256B-B10, μPD43256B-B12, μPD43256B-B15]

Input Waveform (Rise and Fall Time ≤ 5 ns)

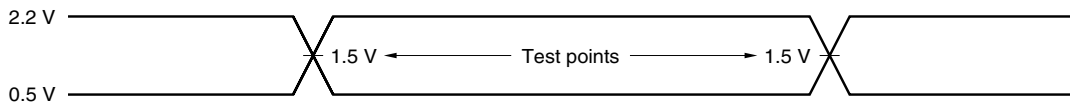

Output Waveform

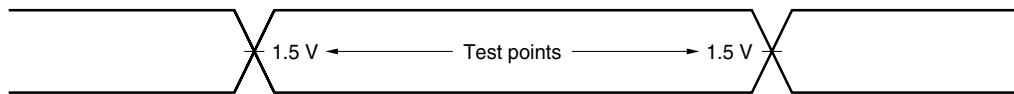

Output Load

AC characteristics should be measured with the following output load conditions.

t_{AA} , t_{ACS} , t_{OE} , t_{OH}	t_{CHZ} , t_{CLZ} , t_{OHZ} , t_{OLZ} , t_{WHZ} , t_{OW}
1TTL + 100 pF	1TTL + 5 pF

Read Cycle (1/2)

Parameter	Symbol	V _{CC} ≥ 4.5 V				Unit	Condition
		μPD43256B-70		μPD43256B-85 μPD43256B-A85/A10/A12 μPD43256B-B10/B12/B15			
		MIN.	MAX.	MIN.	MAX.		
Read cycle time	t _{RC}	70		85		ns	Note
Address access time	t _{AA}		70		85	ns	
/CS access time	t _{ACS}		70		85	ns	
/OE access time	t _{OE}		35		40	ns	
Output hold from address change	t _{OH}	10		10		ns	
/CS to output in low impedance	t _{CLZ}	10		10		ns	
/OE to output in low impedance	t _{OLZ}	5		5		ns	
/CS to output in high impedance	t _{CHZ}		30		30	ns	
/OE to output in high impedance	t _{OHZ}		30		30	ns	

Note See the **output load**.

Remark These AC characteristics are in common regardless of package types and L, LL versions.

Read Cycle (2/2)

Parameter	Symbol	V _{CC} ≥ 3.0 V						V _{CC} ≥ 2.7 V						Unit	Con- dition
		μPD43256B -A85		μPD43256B -A10		μPD43256B -A12		μPD43256B -B10		μPD43256B -B12		μPD43256B -B15			
		MIN.	MAX.	MIN.	MAX.	MIN.	MAX.	MIN.	MAX.	MIN.	MAX.	MIN.	MAX.		
Read cycle time	t _{RC}	85		100		120		100		120		150		ns	Note
Address access time	t _{AA}		85		100		120		100		120		150	ns	
/CS access time	t _{ACS}		85		100		120		100		120		150	ns	
/OE access time	t _{OE}		50		60		60		60		60		70	ns	
Output hold from address change	t _{OH}	10		10		10		10		10		10		ns	
/CS to output in low impedance	t _{CLZ}	10		10		10		10		10		10		ns	
/OE to output in low impedance	t _{OLZ}	5		5		5		5		5		5		ns	
/CS to output in high impedance	t _{CHZ}		35		35		40		35		40		50	ns	
/OE to output in high impedance	t _{OHZ}		35		35		40		35		40		50	ns	

Note See the **output load**.

Remark These AC characteristics are in common regardless of package types.

Read Cycle Timing Chart

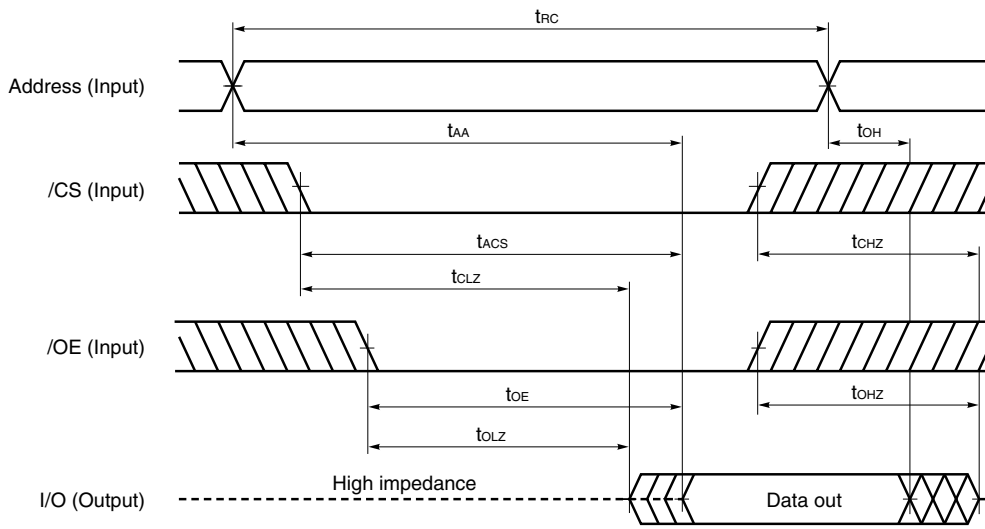

Remark In read cycle, /WE should be fixed to high level.

Write Cycle (1/2)

Parameter	Symbol	V _{CC} ≥ 4.5 V				Unit	Condition
		μPD43256B-70		μPD43256B-85 μPD43256B-A85/A10/A12 μPD43256B-B10/B12/B15			
		MIN.	MAX.	MIN.	MAX.		
Write cycle time	t _{wc}	70		85		ns	
/CS to end of write	t _{cw}	50		70		ns	
Address valid to end of write	t _{aw}	50		70		ns	
Write pulse width	t _{wP}	55		60		ns	
Data valid to end of write	t _{dW}	30		35		ns	
Data hold time	t _{dH}	0		0		ns	
Address setup time	t _{as}	0		0		ns	
Write recovery time	t _{wR}	0		0		ns	
/WE to output in high impedance	t _{whZ}		30		30	ns	Note
Output active from end of write	t _{ow}	10		10		ns	

Note See the **output load**.

Remark These AC characteristics are in common regardless of package types and L, LL versions.

Write Cycle (2/2)

Parameter	Symbol	V _{CC} ≥ 3.0 V						V _{CC} ≥ 2.7 V						Unit	Con- dition
		μPD43256B -A85		μPD43256B -A10		μPD43256B -A12		μPD43256B -B10		μPD43256B -B12		μPD43256B -B15			
		MIN.	MAX.	MIN.	MAX.	MIN.	MAX.	MIN.	MAX.	MIN.	MAX.	MIN.	MAX.		
Write cycle time	t _{wc}	85		100		120		100		120		150		ns	
/CS to end of write	t _{cw}	70		70		90		70		90		100		ns	
Address valid to end of write	t _{aw}	70		70		90		70		90		100		ns	
Write pulse width	t _{wP}	60		60		80		60		80		90		ns	
Data valid to end of write	t _{dW}	60		60		70		60		70		80		ns	
Data hold time	t _{dH}	0		0		0		0		0		0		ns	
Address setup	t _{as}	0		0		0		0		0		0		ns	
Write recovery	t _{wR}	0		0		0		0		0		0		ns	
/WE to output in high impedance	t _{whZ}		30		35		40		35		40		50	ns	Note
Output active from end of write	t _{ow}	10		10		10		10		10		10		ns	

Note See the **output load**.

Remark These AC characteristics are in common regardless of package types.

Write Cycle Timing Chart 1 (/WE Controlled)

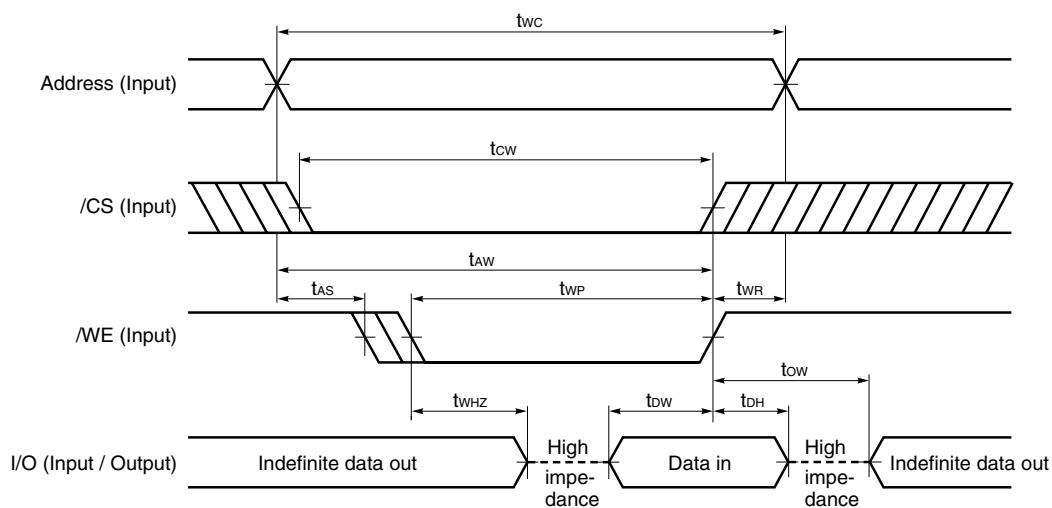

Cautions 1. \overline{CS} or \overline{WE} should be fixed to high level during address transition.

2. When I/O pins are in the output state, therefore the input signals must not be applied to the output.

Remarks 1. Write operation is done during the overlap time of a low level \overline{CS} and a low level \overline{WE} .

2. When \overline{WE} is at low level, the I/O pins are always high impedance. When \overline{WE} is at high level, read operation is executed. Therefore \overline{OE} should be at high level to make the I/O pins high impedance.
3. If \overline{CS} changes to low level at the same time or after the change of \overline{WE} to low level, the I/O pins will remain high impedance state.

Write Cycle Timing Chart 2 (/CS Controlled)

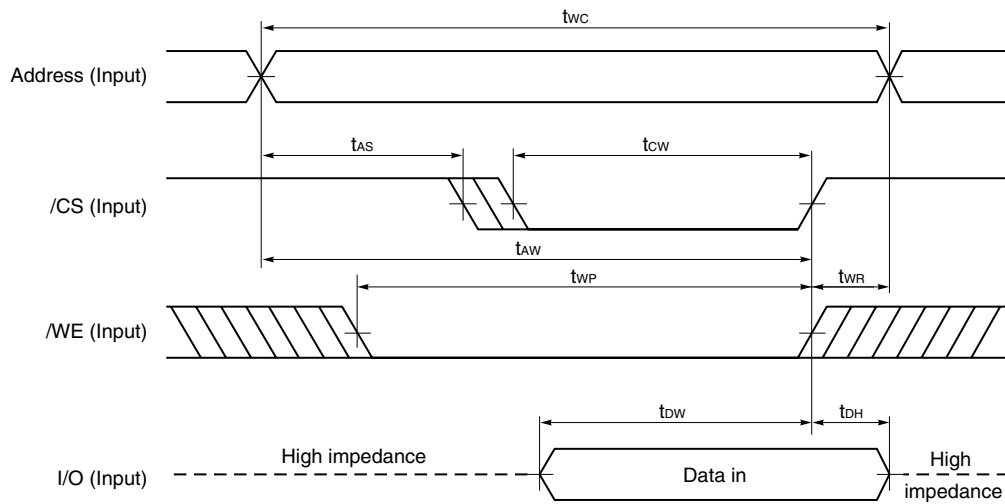

- Cautions**
1. /CS or /WE should be fixed to high level during address transition.
 2. When I/O pins are in the output state, therefore the input signals must not be applied to the output.

Remark Write operation is done during the overlap time of a low level /CS and a low level /WE.

Low V_{CC} Data Retention Characteristics (T_A = 0 to 70 °C)

Parameter	Symbol	Test Condition	μPD43256B-xxL			μPD43256B-xxLL μPD43256B-Axx μPD43256B-Bxx			Unit
			MIN.	TYP.	MAX.	MIN.	TYP.	MAX.	
Data retention supply voltage	V _{CCDR}	/CS ≥ V _{CC} - 0.2 V	2.0		5.5	2.0		5.5	V
Data retention supply current	I _{CCDR}	V _{CC} = 3.0 V, /CS ≥ V _{CC} - 0.2 V		0.5	20 ^{Note1}		0.5	7 ^{Note2}	μA
Chip deselection to data retention mode	t _{CDR}		0			0			ns
Operation recovery time	t _R		5			5			ms

Notes 1. 3 μA (T_A ≤ 40 °C)

2. 2 μA (T_A ≤ 40 °C), 1 μA (T_A ≤ 25 °C)

Data Retention Timing Chart

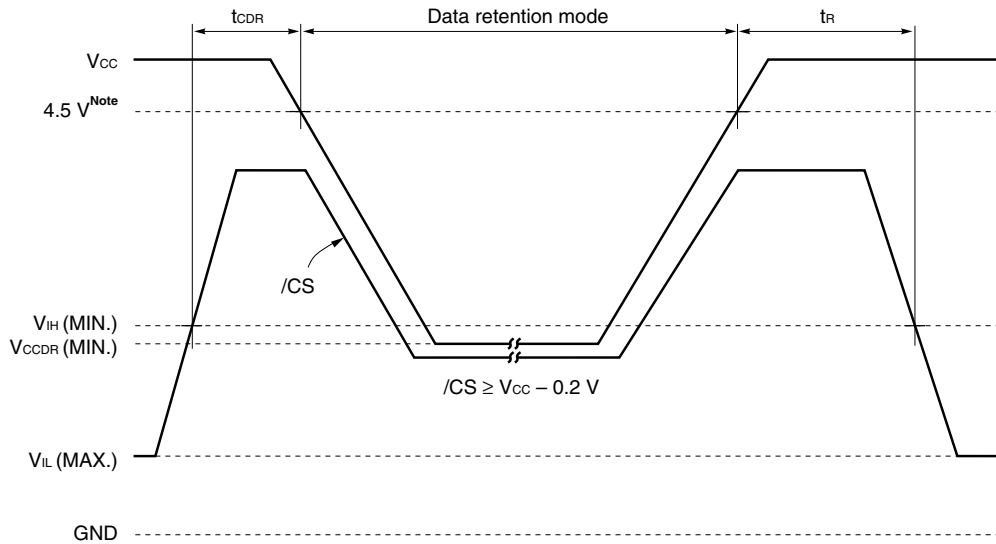

Note A version : 3.0 V, B version : 2.7 V

Remark The other pins (Address, /OE, /WE, I/O) can be in high impedance state.

Package Drawings

28-PIN PLASTIC DIP (15.24 mm (600))

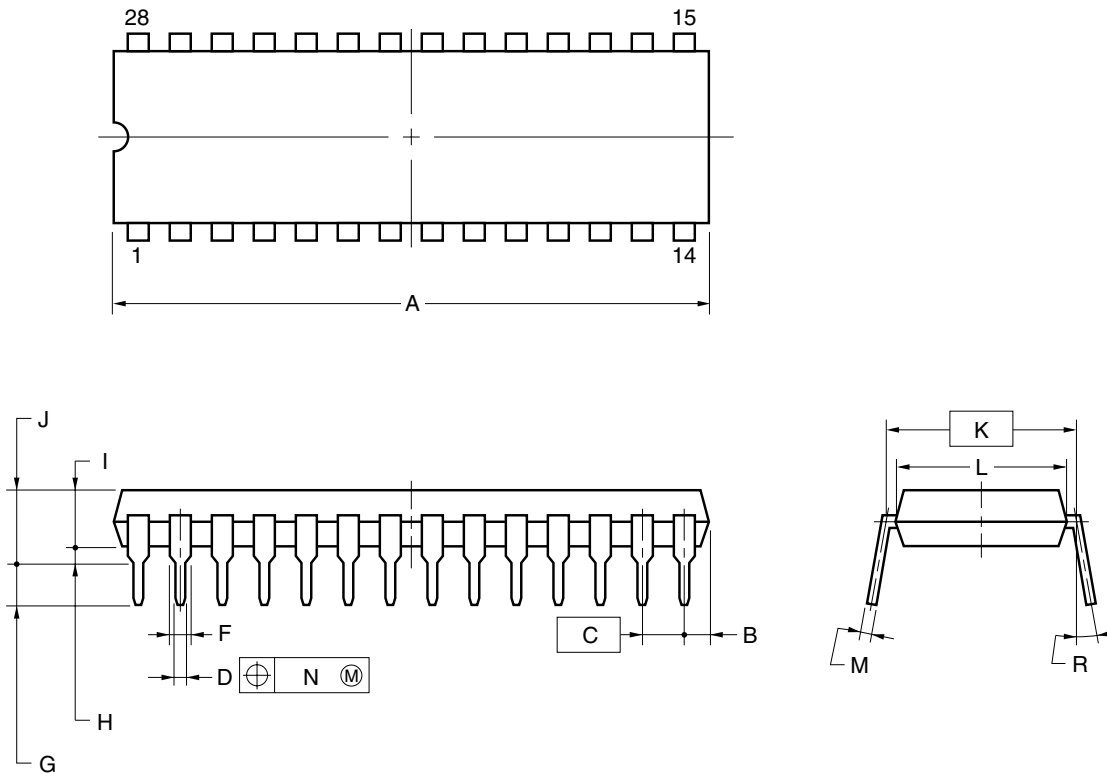

NOTES

1. Each lead centerline is located within 0.25 mm of its true position (T.P.) at maximum material condition.
2. Item "K" to center of leads when formed parallel.

ITEM	MILLIMETERS
A	38.10 MAX.
B	2.54 MAX.
C	2.54 (T.P.)
D	0.50±0.10
F	1.2 MIN.
G	3.6±0.3
H	0.51 MIN.
I	4.31 MAX.
J	5.72 MAX.
K	15.24 (T.P.)
L	13.2
M	0.25 ^{+0.10} _{-0.05}
N	0.25
R	0 - 15°

P28C-100-600A1-2

28-PIN PLASTIC SOP (11.43 mm (450))

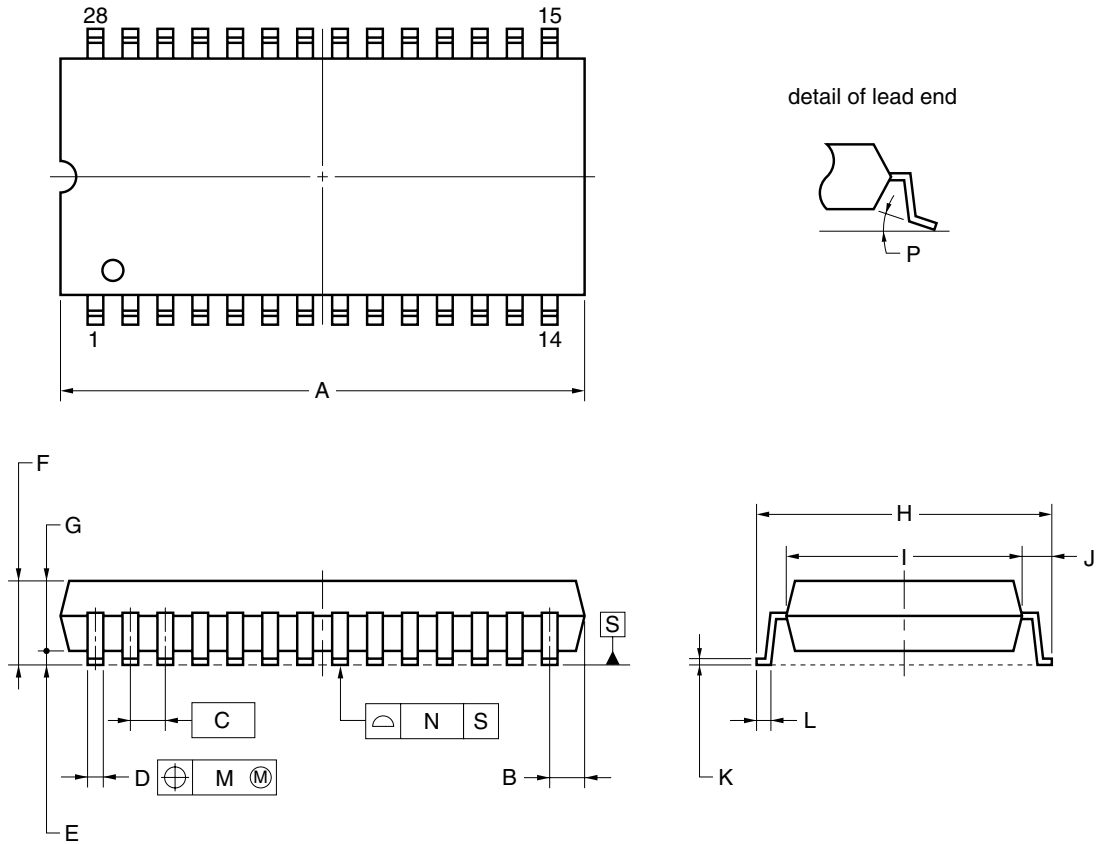

NOTE

Each lead centerline is located within 0.12 mm of its true position (T.P.) at maximum material condition.

ITEM	MILLIMETERS
A	18.0 ^{+0.6} _{-0.05}
B	1.27 MAX.
C	1.27 (T.P.)
D	0.42 ^{+0.08} _{-0.07}
E	0.2±0.1
F	2.95 MAX.
G	2.55±0.1
H	11.8±0.3
I	8.4±0.1
J	1.7±0.2
K	0.22±0.05
L	0.7±0.2
M	0.12
N	0.10
P	3° ^{+7°} _{-3°}

P28GU-50-450A-4

28-PIN PLASTIC TSOP(I) (8x13.4)

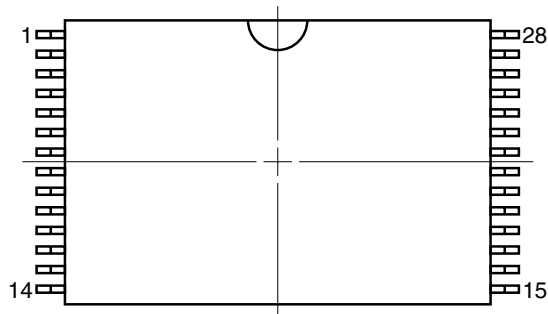

detail of lead end

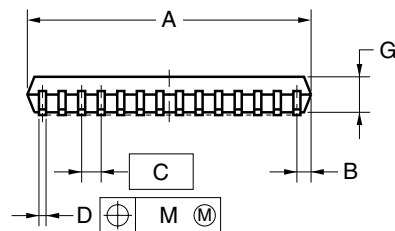
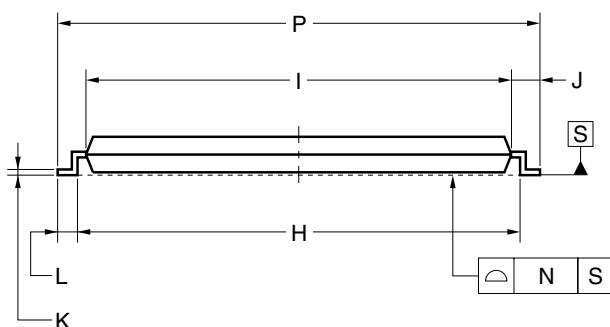
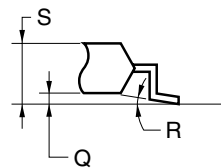

NOTES

1. Each lead centerline is located within 0.08 mm of its true position (T.P.) at maximum material condition.
2. "A" excludes mold flash. (Includes mold flash : 8.4mm MAX.)

ITEM	MILLIMETERS
A	8.0±0.1
B	0.6 MAX.
C	0.55 (T.P.)
D	0.22 ^{+0.08} _{-0.07}
G	1.0
H	12.4±0.2
I	11.8±0.1
J	0.8±0.2
K	0.145 ^{+0.025} _{-0.015}
L	0.5±0.1
M	0.08
N	0.10
P	13.4±0.2
Q	0.1±0.05
R	3 [°] +7 [°] -3 [°]
S	1.2 MAX.

P28GW-55-9JL-2

28-PIN PLASTIC TSOP(I) (8x13.4)

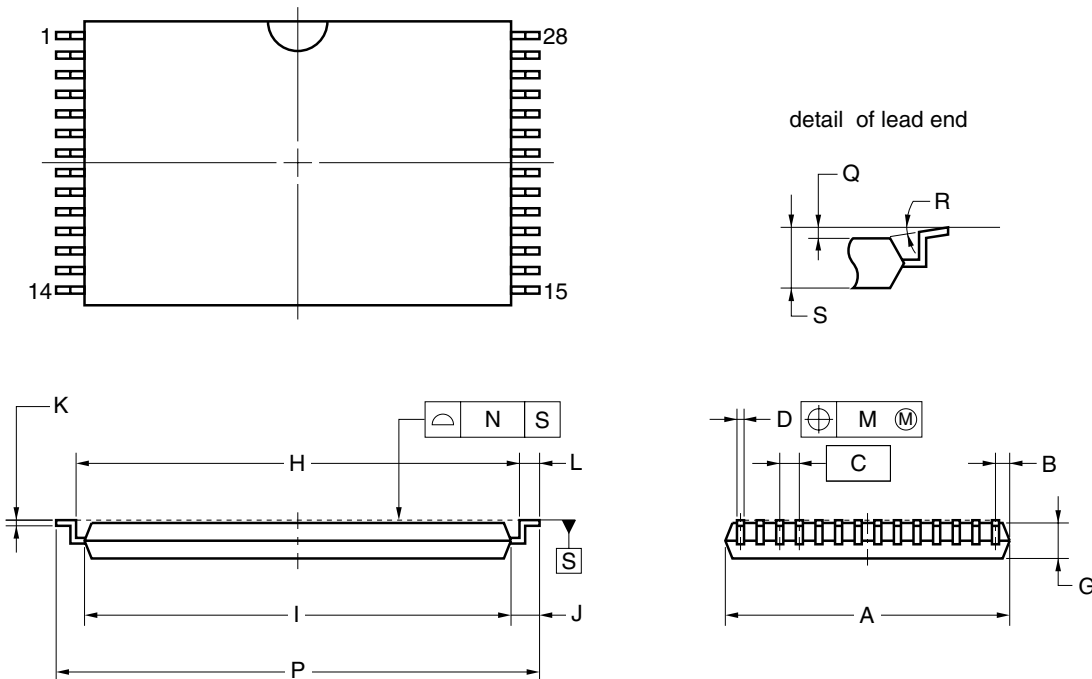

NOTE

1. Each lead centerline is located within 0.08 mm of its true position (T.P.) at maximum material condition.
2. "A" excludes mold flash. (Includes mold flash : 8.4mm MAX.)

ITEM	MILLIMETERS
A	8.0±0.1
B	0.6 MAX.
C	0.55 (T.P.)
D	0.22 ^{+0.08} _{-0.07}
G	1.0
H	12.4±0.2
I	11.8±0.1
J	0.8±0.2
K	0.145 ^{+0.025} _{-0.015}
L	0.5±0.1
M	0.08
N	0.10
P	13.4±0.2
Q	0.1±0.05
R	3° ^{+7°} _{-3°}
S	1.2 MAX.

P28GW-55-9KL-2

Recommended Soldering Conditions

Please consult with our sales offices for soldering conditions of the μPD43256B.

Types of Surface Mount Device

- μPD43256BGU-xxL : 28-pin PLASTIC SOP (11.43 mm (450))
- μPD43256BGU-xxLL : 28-pin PLASTIC SOP (11.43 mm (450))
- μPD43256BGU-Axx : 28-pin PLASTIC SOP (11.43 mm (450))
- μPD43256BGU-Bxx : 28-pin PLASTIC SOP (11.43 mm (450))
- μPD43256BGW-xxLL-9JL : 28-pin PLASTIC TSOP (I) (8x13.4) (Normal bent)
- μPD43256BGW-xxLL-9KL : 28-pin PLASTIC TSOP (I) (8x13.4) (Reverse bent)
- μPD43256BGW-Axx-9JL : 28-pin PLASTIC TSOP (I) (8x13.4) (Normal bent)
- μPD43256BGW-Axx-9KL : 28-pin PLASTIC TSOP (I) (8x13.4) (Reverse bent)
- μPD43256BGW-Bxx-9JL : 28-pin PLASTIC TSOP (I) (8x13.4) (Normal bent)
- μPD43256BGW-Bxx-9KL : 28-pin PLASTIC TSOP (I) (8x13.4) (Reverse bent)
- μPD43256BGU-xxL-A : 28-pin PLASTIC SOP (11.43 mm (450))
- μPD43256BGU-xxLL-A : 28-pin PLASTIC SOP (11.43 mm (450))
- μPD43256BGU-Axx-A : 28-pin PLASTIC SOP (11.43 mm (450))
- μPD43256BGU-Bxx-A : 28-pin PLASTIC SOP (11.43 mm (450))
- μPD43256BGW-xxLL-9JL-A : 28-pin PLASTIC TSOP (I) (8x13.4) (Normal bent)
- μPD43256BGW-xxLL-9KL-A : 28-pin PLASTIC TSOP (I) (8x13.4) (Reverse bent)
- μPD43256BGW-Axx-9JL-A : 28-pin PLASTIC TSOP (I) (8x13.4) (Normal bent)
- μPD43256BGW-Axx-9KL-A : 28-pin PLASTIC TSOP (I) (8x13.4) (Reverse bent)
- μPD43256BGW-Bxx-9JL-A : 28-pin PLASTIC TSOP (I) (8x13.4) (Normal bent)
- μPD43256BGW-Bxx-9KL-A : 28-pin PLASTIC TSOP (I) (8x13.4) (Reverse bent)

Types of Through Hole Mount Device

- μPD43256BCZ-xxL : 28-pin PLASTIC DIP (15.24 mm (600))
- μPD43256BCZ-xxLL : 28-pin PLASTIC DIP (15.24 mm (600))

Soldering process	Soldering conditions
Wave soldering (only to leads)	Solder temperature : 260 °C or below, Flow time : 10 seconds or below
Partial heating method	Terminal temperature : 300 °C or below, Time : 3 seconds or below (Per one lead)

Caution Do not jet molten solder on the surface of package.

Revision History

Edition/ Date	Page		Type of revision	Location	Description (Previous edition → This edition)
	This edition	Previous edition			
14th edition/ Jun. 2006	p.1	p.1	Deletion	–	Description of Version X and P has been deleted.

[MEMO]

[MEMO]

[MEMO]

NOTES FOR CMOS DEVICES

① VOLTAGE APPLICATION WAVEFORM AT INPUT PIN

Waveform distortion due to input noise or a reflected wave may cause malfunction. If the input of the CMOS device stays in the area between V_{IL} (MAX) and V_{IH} (MIN) due to noise, etc., the device may malfunction. Take care to prevent chattering noise from entering the device when the input level is fixed, and also in the transition period when the input level passes through the area between V_{IL} (MAX) and V_{IH} (MIN).

② HANDLING OF UNUSED INPUT PINS

Unconnected CMOS device inputs can be cause of malfunction. If an input pin is unconnected, it is possible that an internal input level may be generated due to noise, etc., causing malfunction. CMOS devices behave differently than Bipolar or NMOS devices. Input levels of CMOS devices must be fixed high or low by using pull-up or pull-down circuitry. Each unused pin should be connected to V_{DD} or GND via a resistor if there is a possibility that it will be an output pin. All handling related to unused pins must be judged separately for each device and according to related specifications governing the device.

③ PRECAUTION AGAINST ESD

A strong electric field, when exposed to a MOS device, can cause destruction of the gate oxide and ultimately degrade the device operation. Steps must be taken to stop generation of static electricity as much as possible, and quickly dissipate it when it has occurred. Environmental control must be adequate. When it is dry, a humidifier should be used. It is recommended to avoid using insulators that easily build up static electricity. Semiconductor devices must be stored and transported in an anti-static container, static shielding bag or conductive material. All test and measurement tools including work benches and floors should be grounded. The operator should be grounded using a wrist strap. Semiconductor devices must not be touched with bare hands. Similar precautions need to be taken for PW boards with mounted semiconductor devices.

④ STATUS BEFORE INITIALIZATION

Power-on does not necessarily define the initial status of a MOS device. Immediately after the power source is turned ON, devices with reset functions have not yet been initialized. Hence, power-on does not guarantee output pin levels, I/O settings or contents of registers. A device is not initialized until the reset signal is received. A reset operation must be executed immediately after power-on for devices with reset functions.

⑤ POWER ON/OFF SEQUENCE

In the case of a device that uses different power supplies for the internal operation and external interface, as a rule, switch on the external power supply after switching on the internal power supply. When switching the power supply off, as a rule, switch off the external power supply and then the internal power supply. Use of the reverse power on/off sequences may result in the application of an overvoltage to the internal elements of the device, causing malfunction and degradation of internal elements due to the passage of an abnormal current.

The correct power on/off sequence must be judged separately for each device and according to related specifications governing the device.

⑥ INPUT OF SIGNAL DURING POWER OFF STATE

Do not input signals or an I/O pull-up power supply while the device is not powered. The current injection that results from input of such a signal or I/O pull-up power supply may cause malfunction and the abnormal current that passes in the device at this time may cause degradation of internal elements. Input of signals during the power off state must be judged separately for each device and according to related specifications governing the device.

- **The information in this document is current as of June, 2006. The information is subject to change without notice. For actual design-in, refer to the latest publications of NEC Electronics data sheets or data books, etc., for the most up-to-date specifications of NEC Electronics products. Not all products and/or types are available in every country. Please check with an NEC Electronics sales representative for availability and additional information.**
- No part of this document may be copied or reproduced in any form or by any means without the prior written consent of NEC Electronics. NEC Electronics assumes no responsibility for any errors that may appear in this document.
- NEC Electronics does not assume any liability for infringement of patents, copyrights or other intellectual property rights of third parties by or arising from the use of NEC Electronics products listed in this document or any other liability arising from the use of such products. No license, express, implied or otherwise, is granted under any patents, copyrights or other intellectual property rights of NEC Electronics or others.
- Descriptions of circuits, software and other related information in this document are provided for illustrative purposes in semiconductor product operation and application examples. The incorporation of these circuits, software and information in the design of a customer's equipment shall be done under the full responsibility of the customer. NEC Electronics assumes no responsibility for any losses incurred by customers or third parties arising from the use of these circuits, software and information.
- While NEC Electronics endeavors to enhance the quality, reliability and safety of NEC Electronics products, customers agree and acknowledge that the possibility of defects thereof cannot be eliminated entirely. To minimize risks of damage to property or injury (including death) to persons arising from defects in NEC Electronics products, customers must incorporate sufficient safety measures in their design, such as redundancy, fire-containment and anti-failure features.
- NEC Electronics products are classified into the following three quality grades: "Standard", "Special" and "Specific".

The "Specific" quality grade applies only to NEC Electronics products developed based on a customer-designated "quality assurance program" for a specific application. The recommended applications of an NEC Electronics product depend on its quality grade, as indicated below. Customers must check the quality grade of each NEC Electronics product before using it in a particular application.

"Standard": Computers, office equipment, communications equipment, test and measurement equipment, audio and visual equipment, home electronic appliances, machine tools, personal electronic equipment and industrial robots.

"Special": Transportation equipment (automobiles, trains, ships, etc.), traffic control systems, anti-disaster systems, anti-crime systems, safety equipment and medical equipment (not specifically designed for life support).

"Specific": Aircraft, aerospace equipment, submersible repeaters, nuclear reactor control systems, life support systems and medical equipment for life support, etc.

The quality grade of NEC Electronics products is "Standard" unless otherwise expressly specified in NEC Electronics data sheets or data books, etc. If customers wish to use NEC Electronics products in applications not intended by NEC Electronics, they must contact an NEC Electronics sales representative in advance to determine NEC Electronics' willingness to support a given application.

(Note)

- (1) "NEC Electronics" as used in this statement means NEC Electronics Corporation and also includes its majority-owned subsidiaries.
- (2) "NEC Electronics products" means any product developed or manufactured by or for NEC Electronics (as defined above).