

MONOLITHIC CD-ROM/DVD-ROM 3-PHASE SPINDLE MOTOR DRIVER

DESCRIPTION

The μ PD16882 is a CD-ROM/DVD-ROM 3-phase spindle motor driver consisting of a CMOS controller and MOS bridge outputs.

By employing 3-phase full-wave PWM as the drive method and MOSFETs at the output stage, it has been possible to reduce the power consumption of the μ PD16882 ever further than the drivers that use bipolar transistors.

By using a 30-pin shrink SOP package, a more compact-size has been achieved.

FEATURES

- Supply voltage for controller block: 5 V, supply voltage for output block: 12 V
- Low on-state resistance (total on-state resistance of upper and lower transistors) output $R_{ON} = 1.1 \Omega$ (TYP.)
- Low power consumption due to 3-phase full-wave PWM drive method
- On-chip hole bias switch (linked with STB pin)
- On-chip IND pulse switching function
- START/STOP pin included, acting as a brake during STOP
- Brake pin enabling reverse brake and short brake switching
- Standby pin included, turning off internal circuit in standby (Output high impedance)
- Low current consumption: $I_{DD} = 3 \text{ mA}$ (Max.), $I_{DD(ST)} = 1 \mu\text{A}$ (Max.)
- On-chip thermal shutdown circuit
- On-chip undervoltage lockout circuit
- Overcurrent protector (can be externally set by external resistor)
- On-chip reverse revolution prevention circuit
- 30-pin plastic shrink SOP (7.62 mm (300))

ORDERING INFORMATION

Part Number	Package
μ PD16882GS	30-pin shrink SOP (7.62 mm (300))

The information in this document is subject to change without notice. Before using this document, please confirm that this is the latest version.
 Not all devices/types available in every country. Please check with local NEC representative for availability and additional information.

1. ABSOLUTE MAXIMUM RATINGS (T_A = 25°C)

Parameter	Symbol	Conditions	Ratings	Unit
Supply voltage	V _{DD}	Control block	-0.5 to +6.0	V
	V _M	Motor block	-0.5 to +13.5	V
Output pin voltage	V _{OUT}		-0.5 to +15.0	V
Input voltage	V _{IN}		-0.5 to V _{DD} + 0.5	V
Instantaneous output current ^{Note 1}	I _{OP}	PW ≤ 5 ms, Duty ≤ 10%	±2.0	A/phase
Power consumption ^{Note 2}	P _T		1.0	W
Peak junction temperature	T _{J (MAX)}		150	°C
Storage temperature range	T _{stg}		-55 to +150	°C

Notes 1. Allowable current per phase while on-board

2. When mounted on glass epoxy board (100 mm × 100 mm × 1 mm, copper film area: 15%)

2. RECOMMENDED OPERATING RANGE

Parameter	Symbol	Conditions	MIN.	TYP.	MAX.	Unit
Supply voltage	V _{DD}	Control block	4.5	5.0	5.5	V
	V _M	Motor block	10.8	12.0	13.2	V
Output pin voltage	V _{OUT}				14.8	V
DC output current	I _{O (DC)}		-0.5		+0.5	A/Phase
Instantaneous output current ^{Note}	I _{OP}	PW ≤ 5 ms, Duty ≤ 10%	-1.5		+1.5	A/Phase
Hole bias current	I _{HB}			10	15	mA
IND pin output current	I _{FG}		0	±2.5	±5.0	mA
CL pin input voltage	V _{CL}		0.1		0.4	V
Operating temperature range	T _A		-20		75	°C

Note Allowable current value per phase while on-board

3. ELECTRICAL SPECIFICATIONS (Unless otherwise specified, T_A = 25°C, V_{DD} = 5.0 V, V_M = 12 V)

Parameter	Symbol	Conditions	MIN.	TYP.	MAX.	Unit
Current consumption 1 (during operation)	I _{DD}	STB = V _{DD}		1.5	3.0	mA
Current consumption (in standby)	I _{DD (ST)}	STB = GND			1.0	μA

[Spindle driver]

Parameter	Symbol	Conditions	MIN.	TYP.	MAX.	Unit
1. ST/SP, STB, FGsel, BRsel						
Input voltage, high	V _{IH}		1.8		V _{DD}	V
Input voltage, low	V _{IL}				0.8	V
Input pull-down resistor	R _{IND}			120		kΩ
2. Controller block						
Triangle wave oscillation frequency	f _{PWM}	C _T = 330 pF		75		kHz
3. Hole amplifier						
Common mode input voltage range	V _{Hch}		1.0		3.5	V
Hysteresis voltage	V _{Hhys}	V _H = 2.5 V		15		mV
Input bias current	I _{Hbias}				1.0	μA
4. Hole bias block						
Hole bias voltage	V _{HB}	I _{HB} = 10 mA		0.3	0.5	V
5. FG output						
IND-pin voltage, high	V _{FG_H}	I _{FG} = -2.5 mA	4.0			V
IND-pin voltage, low	V _{FG_L}	I _{FG} = +2.5 mA			0.5	V
6. Output block						
Output on-resistance (upper stage + lower stage)	R _{ON}	I _O = 200 mA T _A = 20°C to 75°C		1.3	1.8	Ω
Leakage current during OFF	I _{DR (OFF)}	In standby			10	μA
Output turn-on time	t _{ON}	R _M = 5 Ω		1.0	2.0	μs
Output turn-off time	t _{OFF}	Star connection		1.0	2.0	μs
7. Torque command						
Control reference input voltage range	ECR		0.3		4.0	V
Control input voltage range	EC		0.3		4.0	V
Input current	I _{IN}			30	50	μA
Input voltage difference ^{Note}	ECR-EC	Duty = 100%		0.75		V
Dead zone (+)	EC_d+	ECR = 1.5 V to 2.5 V	0	+50	+100	mV
Dead zone (-)	EC_d-	ECR = 1.5 V to 2.5 V	-100	-50	0	mV
8. Overcurrent detection block						
Input offset voltage	V _{IO}		-15		15	mV

Note Dead zone not included.

The under voltage lockout circuit (UVLO) operates with a voltage of 4 V TYP.

The thermal shutdown circuit (T.S.D.) operates with T_{CH} > 150°C.

4. PIN FUNCTIONS

Package: 30-pin Plastic Shrink SOP (7.62 mm (300))

Pin No.	Pin Name	I/O	Pin Function
1	IND	O	Index signal output pin
2	STB	I	Standby operation input pin
3	V _M	–	Supply pin for motor block (12 V)
4	V _M	–	Supply pin for motor block (12 V)
5	OUT2	O	Motor connection pin 2
6	RF	O	3-phase bridge output pin
7	RF	O	3-phase bridge output pin
8	OUT1	O	Motor connection pin 1
9	V _M	–	Supply pin for motor block (12 V)
10	V _M	–	Supply pin for motor block (12 V)
11	OUT0	O	Motor connection pin 0
12	RF	O	3-phase bridge output pin
13	RF	O	3-phase bridge output pin
14	I _{SEN}	I	Sense resistor connection pin
15	CL	I	Overcurrent detection voltage input pin
16	GND	–	GND pin
17	BRsel	I	Brake selection pin
18	ST/SP	I	Start/stop input pin
19	FGsel	I	IND pulse selection pin
20	HB	O	Hole bias pin
21	H0–	I	Hole signal input pin 0 (–)
22	H0+	I	Hole signal input pin 0 (+)
23	H1–	I	Hole signal input pin 1 (–)
24	H1+	I	Hole signal input pin 1 (+)
25	H2–	I	Hole signal input pin 2 (–)
26	H2+	I	Hole signal input pin 2 (+)
27	CT	I	Oscillation frequency setup capacitor connection pin
28	V _{DD}	–	Controller block supply pin (5 V)
29	ECR	I	Control reference voltage input pin
30	EC	I	Control voltage input pin

5. BLOCK DIAGRAM

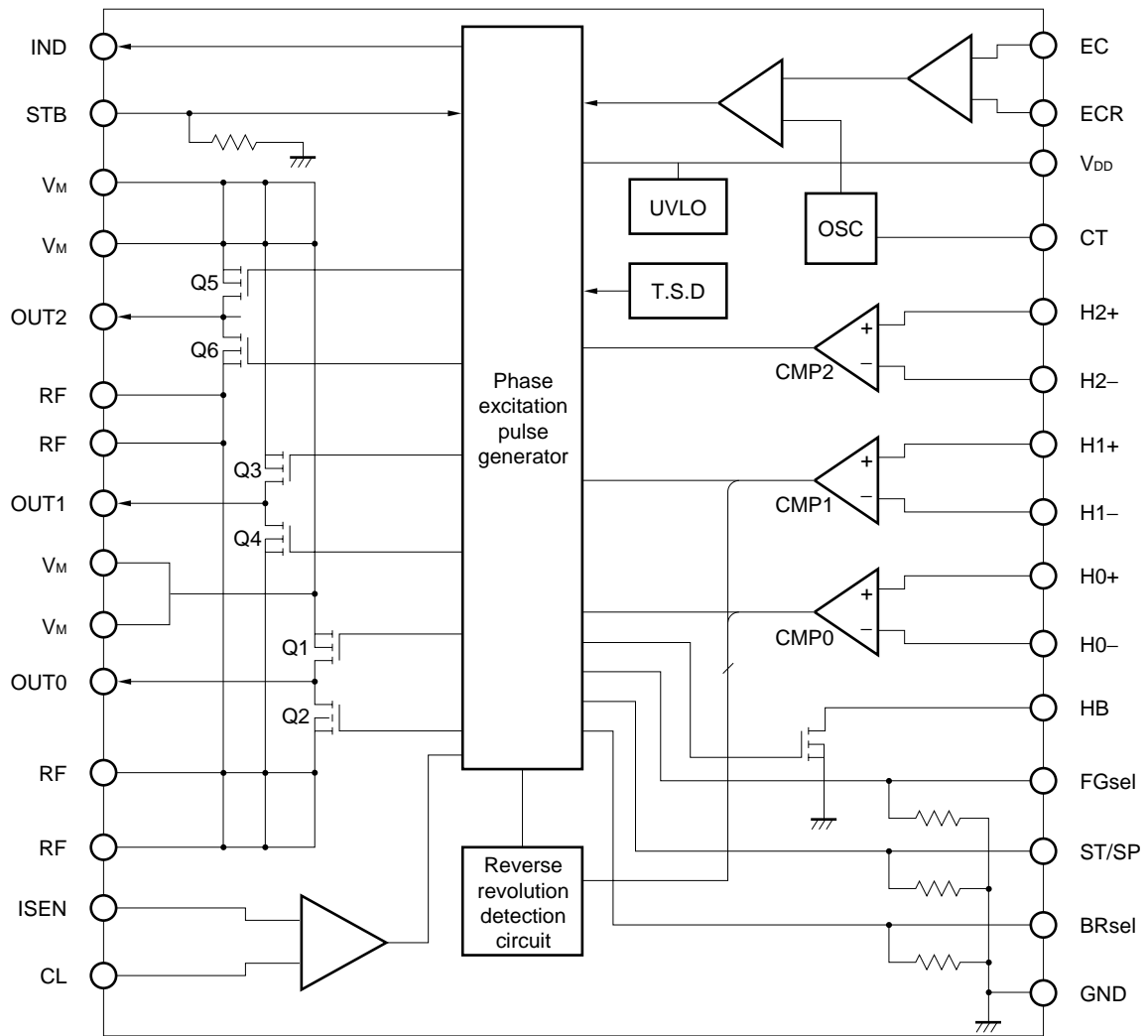

Caution When there is more than one pin of the same kind of pin, all pins should be connected to their targets.

6. STANDARD CHARACTERISTICS CURVES

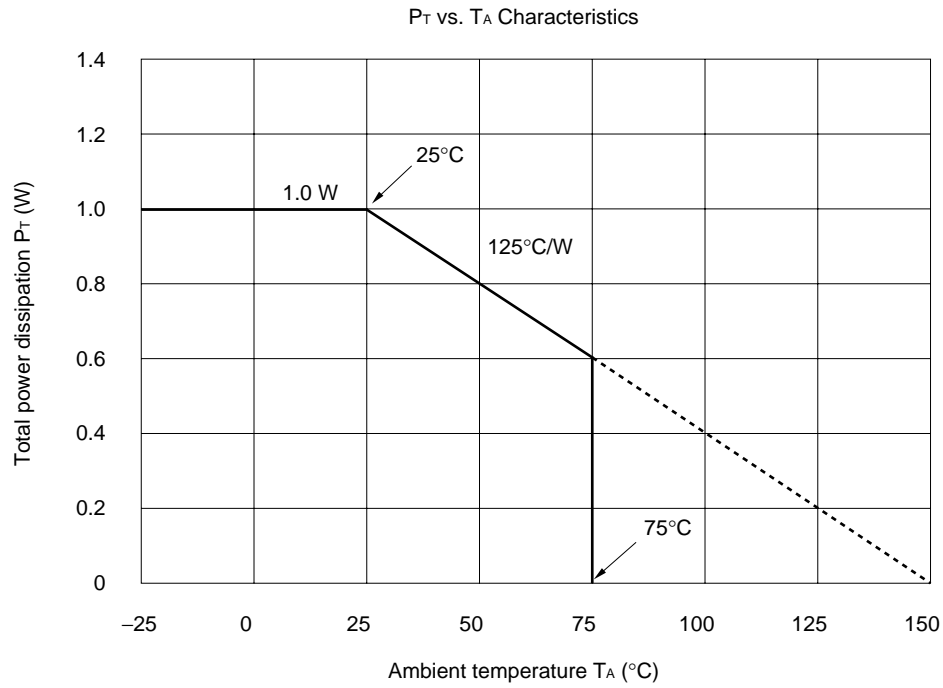

Remark It is possible to apply a maximum of 1.0 W of power when the ambient temperature is 25°C or lower. When the ambient temperature is higher than 25°C, derate based on the above chart. It is possible to apply 0.6 W to the IC when the ambient temperature is 75°C, which is within recommended ambient temperature conditions.

Standard Characteristics Curves (Unless otherwise specified, T_A = 25°C)

I_{DD} and I_{DD}(ST) vs. V_{DD} Characteristics

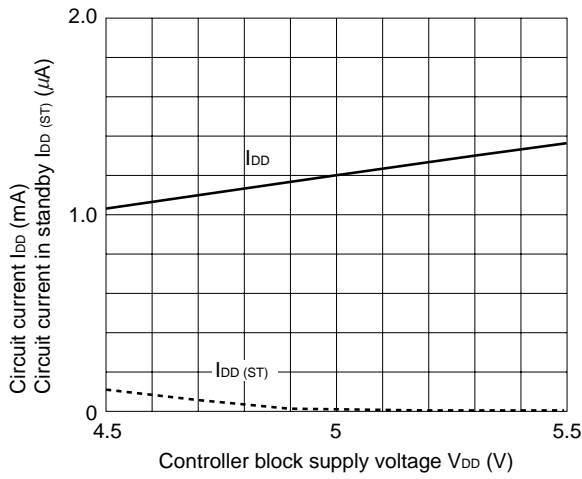

I_{IN} vs. V_{DD} Characteristics (EC and ECR pins)

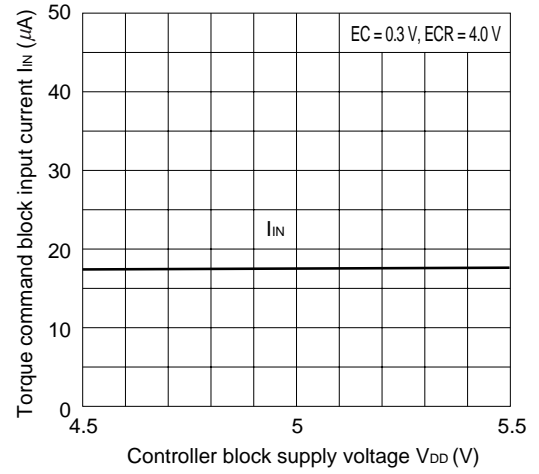

V_{IH} and V_{IL} vs. V_{DD} Characteristics (ST/SP, STB, BRsel, and FGsel pins)

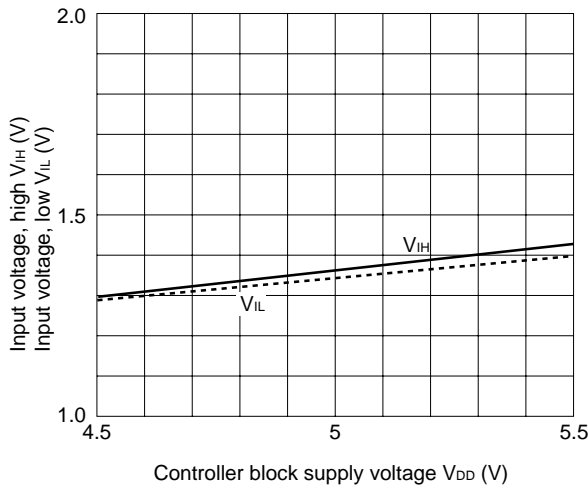

V_{Hys} vs. V_{DD} Characteristics (Hole amplifier input)

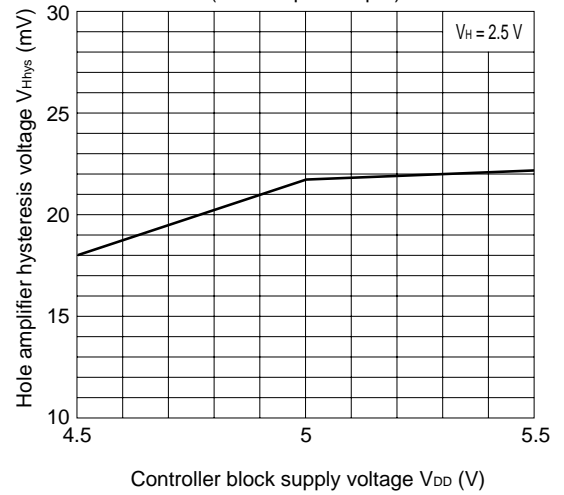

f_{PWM} vs. V_{DD} Characteristics

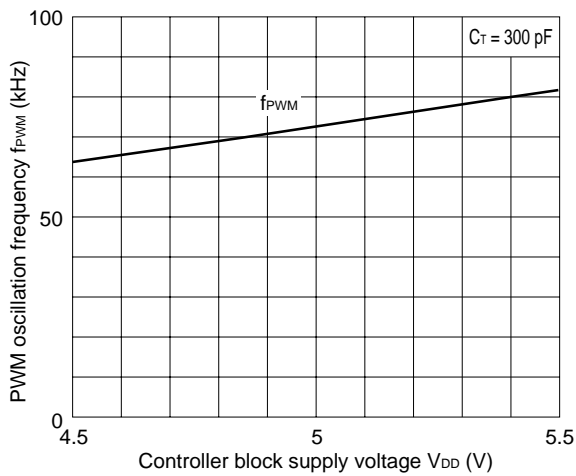

R_{on} vs. T_A Characteristics

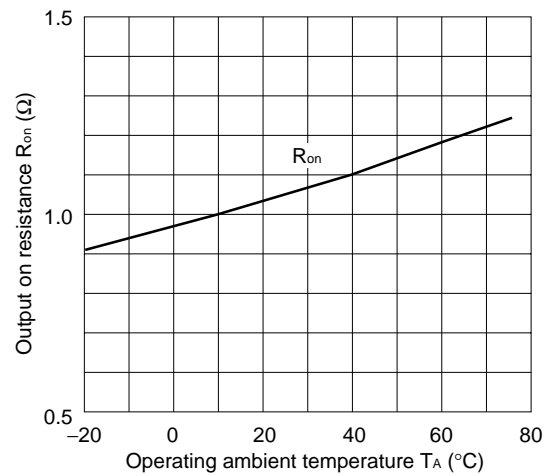

7. FUNCTION OPERATION TABLE

(1) ST/SP (start/stop) function

Turning ON/OFF the spindle can be controlled by the ST/SP pin while the oscillator is operating. When the ST/SP pin is high, the spindle is activated (operating); when it is low, the spindle stops. When the spindle stops, the MOSFET at the high side is ON and the MOSFET at the low side is OFF, serving as a short brake.

• ST/SP = “H”

Input Signal				Circuit Operation	Excited Phase
OUT0	OUT1	OUT2	Low-side PWM		
H	H	L	ON	Excited (operates)	W → V
H	H	L	OFF	Regeneration (brake)	
H	L	L	ON	Excited (operates)	W → U
H	L	L	OFF	Regeneration (brake)	
H	L	H	ON	Excited (operates)	V → U
H	L	H	OFF	Regeneration (brake)	
L	L	H	ON	Excited (operates)	V → W
L	L	H	OFF	Regeneration (brake)	
L	H	H	ON	Excited (operates)	U → W
L	H	H	OFF	Regeneration (brake)	
L	H	L	ON	Excited (operates)	U → V
L	H	L	OFF	Regeneration (brake)	

During regeneration (brake), the input signal goes through the channel of the high-side Pch MOSFET.

• ST/SP = “L”

Drive Timing (Motor Output Signal)				Circuit Operation
OUT0	OUT1	OUT2	PWM	
–	–	–	–	Short brake

(2) Torque control

The output stage is driven by applying a differential voltage between the control reference voltage (ECR) and control input voltage (EC) pins (ECR-EC). With this product, the ECR-EC differential voltage and output PWM duty have a linear relationship. The input deadband is ±50 mV TYP. and the duty of the standard model is 100% at 0.75 V (excluding the deadband).

The μPD16882 also has a break selection pin (BRsel). When this pin goes high, ECR is less than EC and the brake is applied in the reverse direction (refer to the figure and table on the next page).

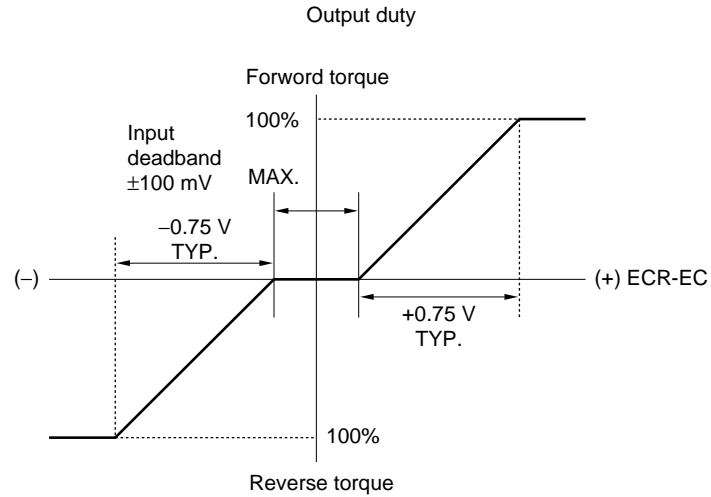

If the BRsel pin goes low, a short brake is applied and only the high side is ON if ECR is equal to or less than EC. When the brake is applied in the reverse direction, the μPD16882 detects the reverse revolution of the motor and then stops. For ECR-ER and the logic of the BRsel pin, refer to the table below.

	BRsel Pin Logic	
	L	H
ECR > EC	Forward	Forward
ECR < EC	Short brake	Reverse brake ^{Note}

Note The μPD16882 stops after it has detected the reverse revolution of the motor. When the motor revolves in the reverse direction, the counter electromotive force flows into the VM pin via the channel of the high-side Pch MOSFET.

(3) FG pulse selection function

This product can vary index signal (FG) output in proportion to the number of revolutions. Depending on the setting of the FGsel pin, either single-phase output or three-phase synthesized output can be selected.

For the logic, refer to the table below.

	FGsel Pin Logic	
	L	H
FG pulse output	Single-phase output	3-phase synthesized output

(4) Standby function

The μPD16882 has a standby function to lower the power consumption when stopped. In the standby status, the oscillator can be stopped to decrease the circuit current. When STB is made low, the spindle enters the standby mode, and goes into a high-impedance state.

When the operation mode is restored, it takes the μPD16882 several 10 μs to start up.

	STB Pin Logic	
	L	H
Circuit status	Standby mode	Operation mode

8. TIMING CHART

(1) Hole signal input

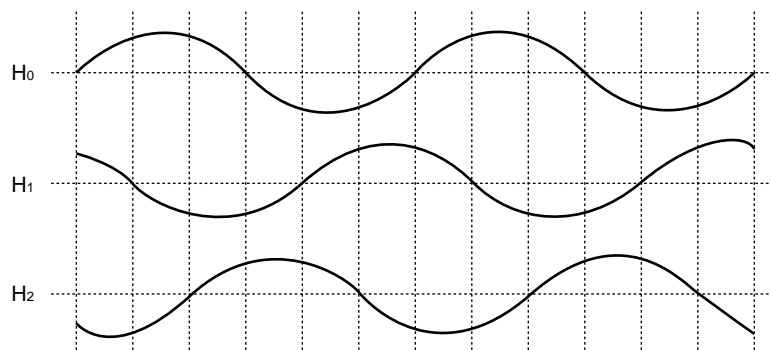

(2) CMP signal (FGsel: GND, single-phase mode (IND1), FGsel: V_{DD}, 3-phase synthesized mode (IND2))

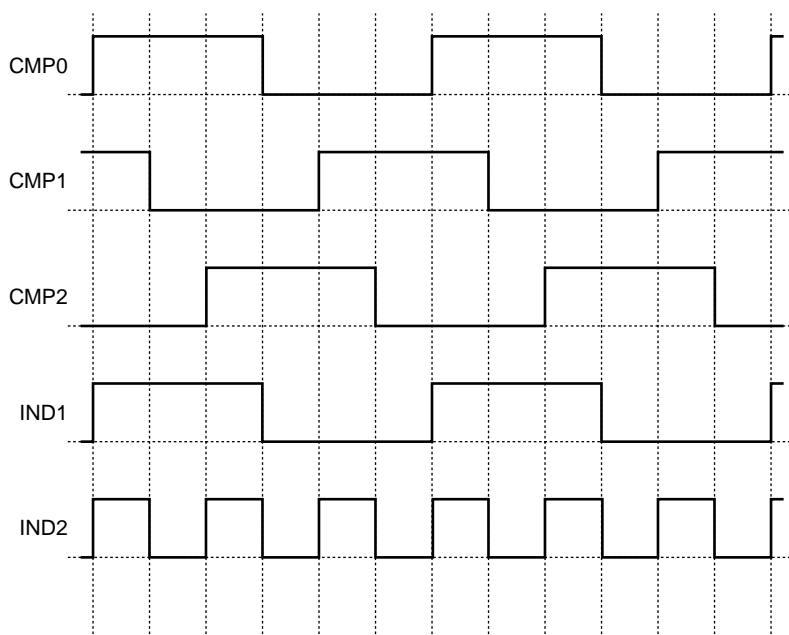

(3) Selection of output MOSFET drive and comparator

Q1		(SW)	(SW)		ON	ON		(SW)	(SW)		ON	ON	
Q2		SW	SW					SW	SW				
Q3	(SW)		ON	ON		(SW)	(SW)		ON	ON		(SW)	(SW)
Q4	SW					SW	SW					SW	SW
Q5	ON	ON		(SW)	(SW)		ON	ON		(SW)	(SW)		ON
Q6				SW	SW					SW	SW		

(4) Motor drive waveform

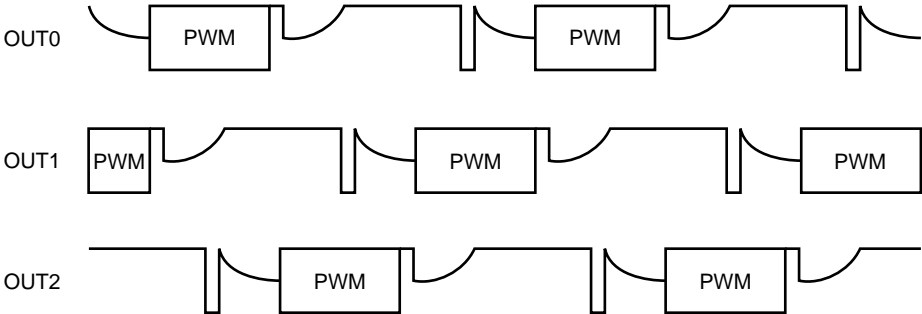

9. APPLICATION CIRCUIT EXAMPLE

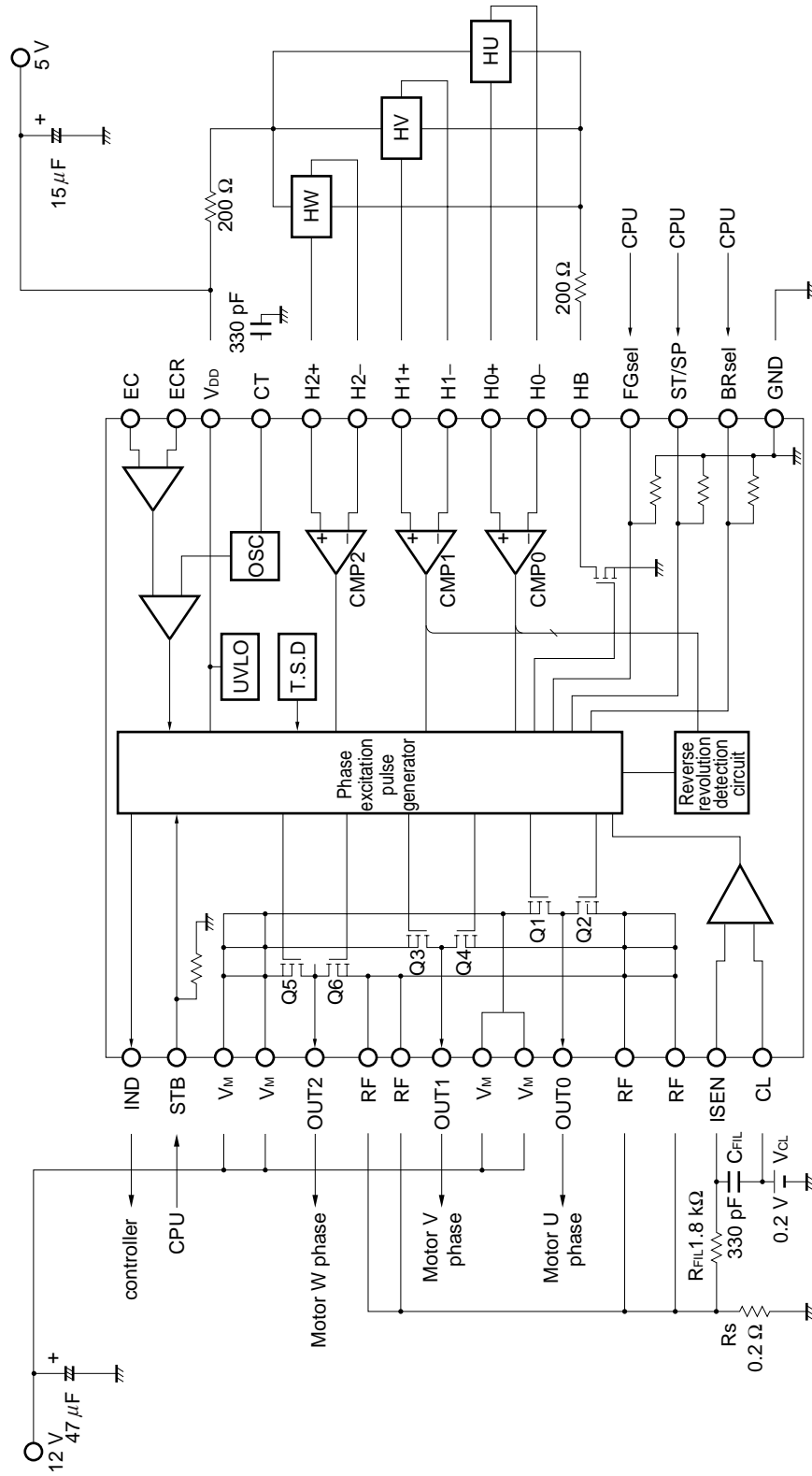

10. PACKAGE DRAWING

30-Pin Plastic Shrink SOP (7.62 mm (300)) (Unit: mm)

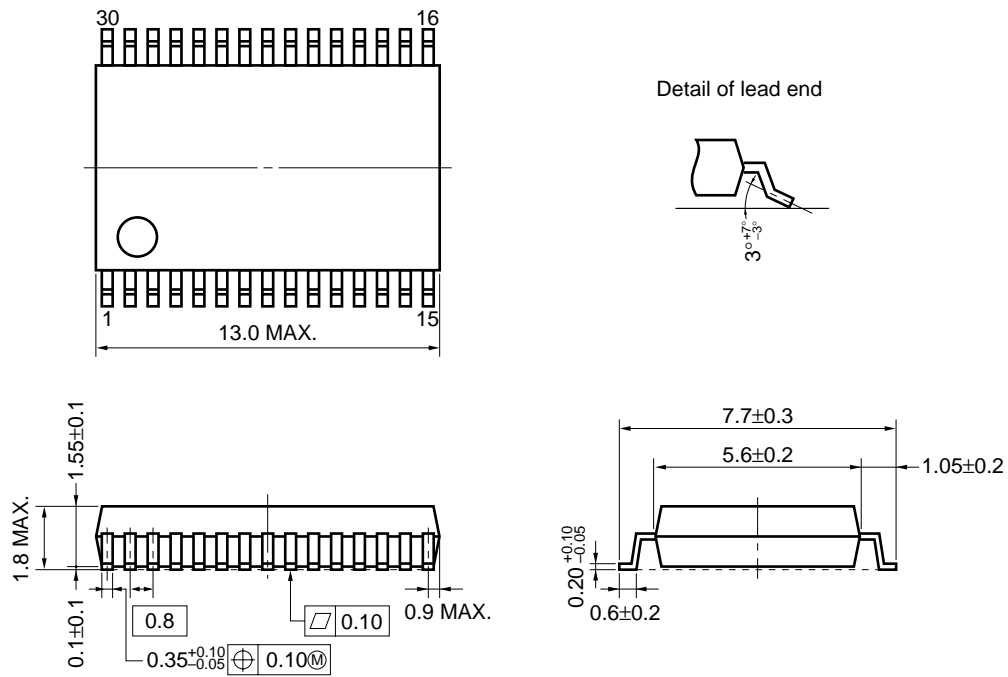

RECOMMENDED SOLDERING CONDITIONS

μPD16882 should be soldered and mounted under the following recommended conditions. For soldering methods and conditions other than those recommended below, contact your NEC sales representative.

Surface Mount Type

For the details of the recommended soldering conditions, refer to the document **Semiconductor Device Mounting Technology Manual (C10535E)**.

μPD16882GS

Soldering Method	Soldering Conditions	Recommended Condition Symbol
Infrared reflow	Package peak temperature: 235°C, Time: 30 sec. Max. (at 210°C or higher), Count: two times, Exposure limit: Not limited ^{Note}	IR35-00-2
VPS	Package peak temperature: 215°C, Time: 40 sec. Max. (at 200°C or higher), Count: two times, Exposure limit: Not limited ^{Note}	VP15-00-2
Wave soldering	Solder bath temperature: 260°C Max., Time: 10 sec. Max., Count: once, Exposure limit: Not limited ^{Note}	WS60-00-1
Partial heating	Pin temperature: 300°C Max., Time: 3 sec. Max., Exposure limit: not limited ^{Note}	

Note After opening the dry pack, store it at 25°C or less and 65% RH or less for the allowable storage period.

Caution Do not use different soldering methods together (except for partial heating).

REFERENCE

Quality Grades on NEC semiconductor Devices	C11531E
Semiconductor Device Mounting Technology Manual	C10535E
NEC Semiconductor Device Reliability/Quality Control System	C12769E
Semiconductor Selection Guide	X13769X

[MEMO]

[MEMO]

NOTES FOR CMOS DEVICES**① PRECAUTION AGAINST ESD FOR SEMICONDUCTORS**

Note:

Strong electric field, when exposed to a MOS device, can cause destruction of the gate oxide and ultimately degrade the device operation. Steps must be taken to stop generation of static electricity as much as possible, and quickly dissipate it once, when it has occurred. Environmental control must be adequate. When it is dry, humidifier should be used. It is recommended to avoid using insulators that easily build static electricity. Semiconductor devices must be stored and transported in an anti-static container, static shielding bag or conductive material. All test and measurement tools including work bench and floor should be grounded. The operator should be grounded using wrist strap. Semiconductor devices must not be touched with bare hands. Similar precautions need to be taken for PW boards with semiconductor devices on it.

② HANDLING OF UNUSED INPUT PINS FOR CMOS

Note:

No connection for CMOS device inputs can be cause of malfunction. If no connection is provided to the input pins, it is possible that an internal input level may be generated due to noise, etc., hence causing malfunction. CMOS devices behave differently than Bipolar or NMOS devices. Input levels of CMOS devices must be fixed high or low by using a pull-up or pull-down circuitry. Each unused pin should be connected to V_{DD} or GND with a resistor, if it is considered to have a possibility of being an output pin. All handling related to the unused pins must be judged device by device and related specifications governing the devices.

③ STATUS BEFORE INITIALIZATION OF MOS DEVICES

Note:

Power-on does not necessarily define initial status of MOS device. Production process of MOS does not define the initial operation status of the device. Immediately after the power source is turned ON, the devices with reset function have not yet been initialized. Hence, power-on does not guarantee out-pin levels, I/O settings or contents of registers. Device is not initialized until the reset signal is received. Reset operation must be executed immediately after power-on for devices having reset function.

Regional Information

Some information contained in this document may vary from country to country. Before using any NEC product in your application, please contact the NEC office in your country to obtain a list of authorized representatives and distributors. They will verify:

- Device availability
- Ordering information
- Product release schedule
- Availability of related technical literature
- Development environment specifications (for example, specifications for third-party tools and components, host computers, power plugs, AC supply voltages, and so forth)
- Network requirements

In addition, trademarks, registered trademarks, export restrictions, and other legal issues may also vary from country to country.

NEC Electronics Inc. (U.S.)

Santa Clara, California
Tel: 408-588-6000
800-366-9782
Fax: 408-588-6130
800-729-9288

NEC Electronics (Germany) GmbH

Duesseldorf, Germany
Tel: 0211-65 03 02
Fax: 0211-65 03 490

NEC Electronics (UK) Ltd.

Milton Keynes, UK
Tel: 01908-691-133
Fax: 01908-670-290

NEC Electronics Italiana s.r.l.

Milano, Italy
Tel: 02-66 75 41
Fax: 02-66 75 42 99

NEC Electronics (Germany) GmbH

Benelux Office
Eindhoven, The Netherlands
Tel: 040-2445845
Fax: 040-2444580

NEC Electronics (France) S.A.

Velizy-Villacoublay, France
Tel: 01-30-67 58 00
Fax: 01-30-67 58 99

NEC Electronics (France) S.A.

Madrid Office
Madrid, Spain
Tel: 91-504-2787
Fax: 91-504-2860

NEC Electronics (Germany) GmbH

Scandinavia Office
Taeby, Sweden
Tel: 08-63 80 820
Fax: 08-63 80 388

NEC Electronics Hong Kong Ltd.

Hong Kong
Tel: 2886-9318
Fax: 2886-9022/9044

NEC Electronics Hong Kong Ltd.

Seoul Branch
Seoul, Korea
Tel: 02-528-0303
Fax: 02-528-4411

NEC Electronics Singapore Pte. Ltd.

United Square, Singapore
Tel: 65-253-8311
Fax: 65-250-3583

NEC Electronics Taiwan Ltd.

Taipei, Taiwan
Tel: 02-2719-2377
Fax: 02-2719-5951

NEC do Brasil S.A.

Electron Devices Division
Guarulhos-SP Brasil
Tel: 55-11-6462-6810
Fax: 55-11-6462-6829

J00.7

- **The information in this document is current as of December, 2000. The information is subject to change without notice. For actual design-in, refer to the latest publications of NEC's data sheets or data books, etc., for the most up-to-date specifications of NEC semiconductor products. Not all products and/or types are available in every country. Please check with an NEC sales representative for availability and additional information.**
 - No part of this document may be copied or reproduced in any form or by any means without prior written consent of NEC. NEC assumes no responsibility for any errors that may appear in this document.
 - NEC does not assume any liability for infringement of patents, copyrights or other intellectual property rights of third parties by or arising from the use of NEC semiconductor products listed in this document or any other liability arising from the use of such products. No license, express, implied or otherwise, is granted under any patents, copyrights or other intellectual property rights of NEC or others.
 - Descriptions of circuits, software and other related information in this document are provided for illustrative purposes in semiconductor product operation and application examples. The incorporation of these circuits, software and information in the design of customer's equipment shall be done under the full responsibility of customer. NEC assumes no responsibility for any losses incurred by customers or third parties arising from the use of these circuits, software and information.
 - While NEC endeavours to enhance the quality, reliability and safety of NEC semiconductor products, customers agree and acknowledge that the possibility of defects thereof cannot be eliminated entirely. To minimize risks of damage to property or injury (including death) to persons arising from defects in NEC semiconductor products, customers must incorporate sufficient safety measures in their design, such as redundancy, fire-containment, and anti-failure features.
 - NEC semiconductor products are classified into the following three quality grades:
"Standard", "Special" and "Specific". The "Specific" quality grade applies only to semiconductor products developed based on a customer-designated "quality assurance program" for a specific application. The recommended applications of a semiconductor product depend on its quality grade, as indicated below. Customers must check the quality grade of each semiconductor product before using it in a particular application.
 - "Standard": Computers, office equipment, communications equipment, test and measurement equipment, audio and visual equipment, home electronic appliances, machine tools, personal electronic equipment and industrial robots
 - "Special": Transportation equipment (automobiles, trains, ships, etc.), traffic control systems, anti-disaster systems, anti-crime systems, safety equipment and medical equipment (not specifically designed for life support)
 - "Specific": Aircraft, aerospace equipment, submersible repeaters, nuclear reactor control systems, life support systems and medical equipment for life support, etc.
- The quality grade of NEC semiconductor products is "Standard" unless otherwise expressly specified in NEC's data sheets or data books, etc. If customers wish to use NEC semiconductor products in applications not intended by NEC, they must contact an NEC sales representative in advance to determine NEC's willingness to support a given application.
- (Note)
- (1) "NEC" as used in this statement means NEC Corporation and also includes its majority-owned subsidiaries.
 - (2) "NEC semiconductor products" means any semiconductor product developed or manufactured by or for NEC (as defined above).