

DUAL CMOS TIMER

Description

The μ PD5556 is a dual CMOS RC timer providing significantly improved performance over the standard bipolar 556 timer, while at the same time being direct replacement for that device in most applications. Improved parameters include low supply current, wide operating supply voltage range, THRESHOLD, TRIGGER and RESET currents as low as 2 pA, no crowbaring of the power supply during output transitions, higher frequency performance, and no requirement to decouple control voltage for stable operation.

Specifically, the μ PD5556 is stable controller capable of producing accurate time delays or frequencies.

In the one-shot mode, the pulse width of each circuit is precisely controlled by one external resistor and capacitor. For astable operation as an oscillator, the free running frequency and the duty cycle are controlled by two external resistors and one capacitor. The circuits can source or sink current large enough to drive TTL loads or provide minimal offsets to drive CMOS loads.

Features

- Exact equivalent in most cases for industry standard 556 timer
- Low supply current
- 3 to 16 V operating voltage range
- Timing from microseconds through hours

CONNECTION DIAGRAM (Top View)

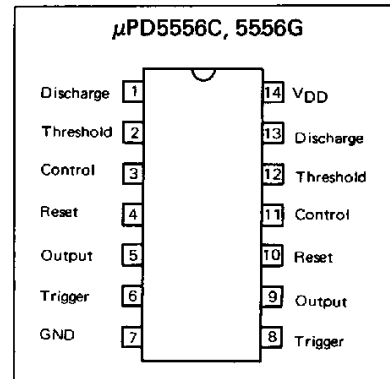

EQUIVALENT CIRCUIT (1/2 circuit)

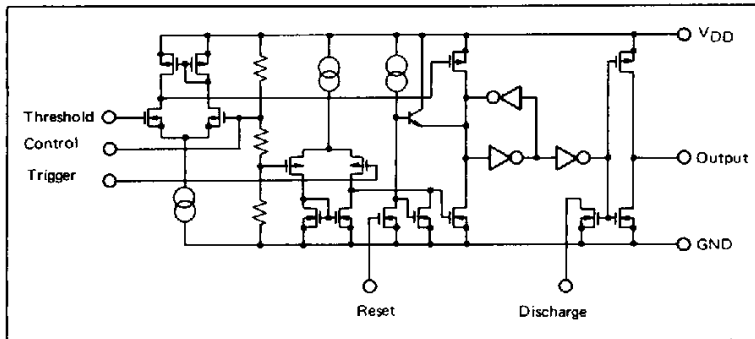

ORDERING INFORMATION

Part Number	Package
μ PD5556C	14 PIN PLASTIC DIP (300 mil)
μ PD5556G2	14 PIN PLASTIC SOP (225 mil)

NEC cannot assume any responsibility for any circuits shown or represent that they are free from patent infringement.

© NEC Corporation 1987

6427525 0070555 257

ABSOLUTE MAXIMUM RATINGS (T_a=25 °C)

PARAMETER		SYMBOL	μPD5556	UNIT
Supply Voltage		V _{DD}	18	V
Input Voltage (Trigger, Threshold Reset, Control)		V _{IN}	$GND - 0.3 \leq V_{IN} \leq V_{DD} + 0.3$	V
Output Current		I _O	100	mA
Operating Temperature Range		T _{opt}	-20 ~ +70	°C
Storage Temperature Range		T _{stg}	-55 ~ +125	°C
Power Dissipation	C Package	P _T	570	mW
	G Package (Note 1)		550	

Note 1: Thermal derating factor is 5.5 mW/°C when ambient temperature is higher than 25 °C.

RECOMMENDED OPERATING CONDITIONS

CHARACTERISTIC	SYMBOL	MIN.	TYP.	MAX.	UNIT
Oscillation Frequency				500	kHz
Supply Voltage	V _{DD}	3		16	V
Input Voltage	V _{IN}	0		V _{DD}	V
Output Sink Current	I _{O SINK}			3.2	mA
Output Source Current	I _{O SOURCE}			1	mA
Operating Temperature	T _{opt}	-20		70	°C

■ 6427525 0070556 193 ■

ELECTRICAL CHARACTERISTICS (T_a=25 °C, V_{DD} =+3~+15 V)

CHARACTERISTIC	SYMBOL	MIN.	TYP.	MAX.	UNIT	CONDITION
Supply Current	I _{DD}		150	500	μA	V _{DD} =5 V
			200	700		V _{DD} =15 V
Threshold Voltage	V _{th}		2/3 V _{DD}		V	
Threshold Current	I _{th}		50		pA	V _{DD} =15 V
			10			V _{DD} =5 V
			1			V _{DD} =3 V
Trigger Voltage	V _{tr}		1/3 V _{DD}		V	
Trigger Current	I _{tr}		50		pA	V _{DD} =15 V
			10			V _{DD} =5 V
			1			V _{DD} =3 V
Reset Voltage (V _O becomes low)	V _{reset}	0.6	1.1	2.0	V	V _{DD} =15 V
		0.6	1.1	2.0		V _{DD} =3 V
Reset Current	I _{reset}		100		pA	V _{RESET} =GND, V _{DD} =15 V
			20			V _{RESET} =GND, V _{DD} =5 V
			2			V _{RESET} =GND, V _{DD} =3 V
Output Low Voltage	V _{OL}		0.06	0.4	V	V _{DD} =15 V, I _{SINK} =3.2 mA
			0.14	0.4		V _{DD} =5 V, I _{SINK} =3.2 mA
Output High Voltage	V _{OH}	14.25	14.85		V	V _{DD} =15 V, I _{SOURCE} =1 mA
		4.0	4.7			V _{DD} =5 V, I _{SOURCE} =1 mA
Output Rise Time	t _{rise}		60		ns	R _L =10 MΩ, C _L =7 pF, V _{DD} =5 V
Output Fall Time	t _{fall}		60		ns	R _L =10 MΩ, C _L =7 pF, V _{DD} =5 V
Max. Oscillation Frequency		500			kHz	Astable Operation
Propagation Delay	t _{pd}		400		ns	Monostable Operation Trigger Level = 0.1 · V _{DD}
Minimum Trigger Pulse Width (V _{DD} =5 V)	t _{tr}		190		ns	Trigger Level = 0.1 · V _{DD}
Control Voltage	V _{cont}		2/3 V _{DD}		V	
Timing Error Initial Accuracy			2		%	R ₁ , R ₂ =1 k~100 kΩ C=0.1 μF
Temperature Drift			50		ppm/°C	V _{DD} =5~15 V
Supply Voltage Drift			1		%/V	

Note 1: To reduce transient switching noise on the supply voltage line, install a bypass capacitor from V_{DD} to ground. Connect the capacitor, with value listed below, close to V_{DD}.

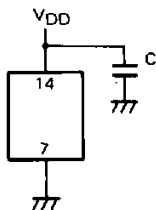

Capacitance C ≥ 0.047 μF V_{DD} ≤ 10 V
C ≥ 0.1 μF V_{DD} ≥ 10 V

Note 2: Install a series resistor (R ≥ 4.7 kΩ) to Reset, when reset is controlled by digital devices.

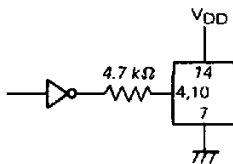

6427525 0070557 02T

TYPICAL PERFORMANCE CHARACTERISTICS

($T_a=25^\circ\text{C}$)

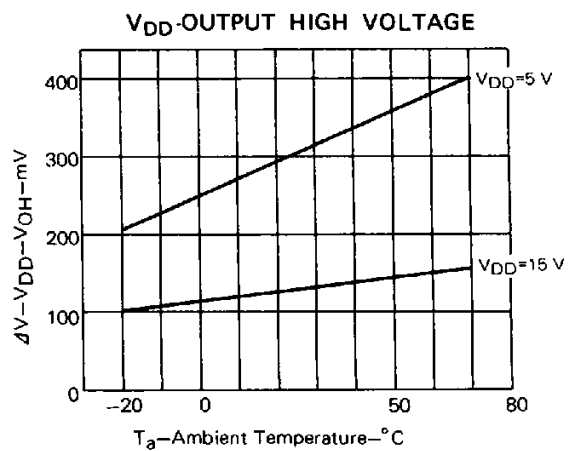
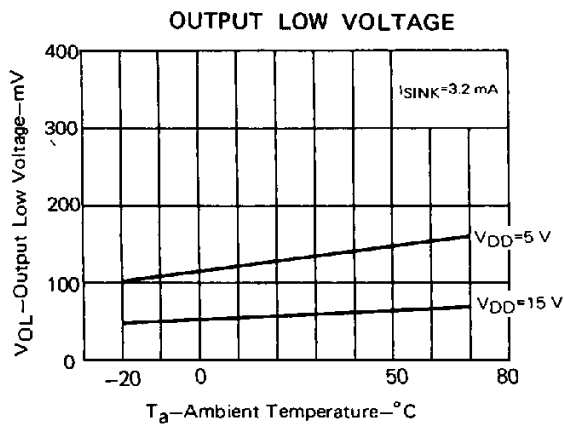
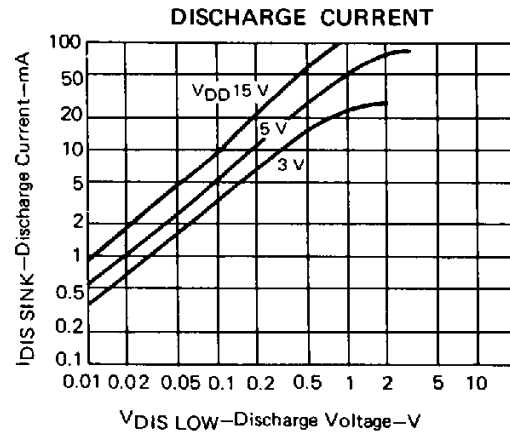
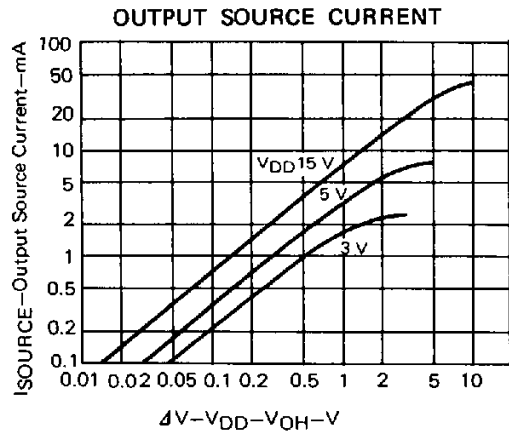
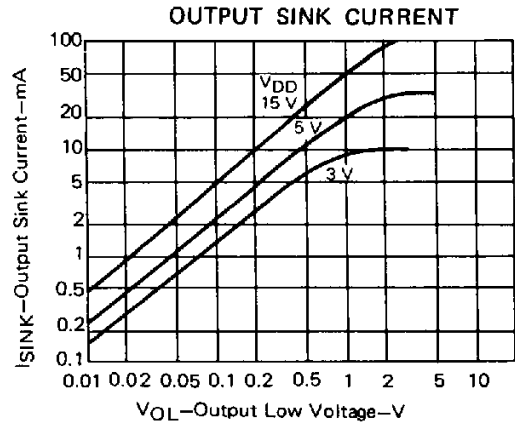
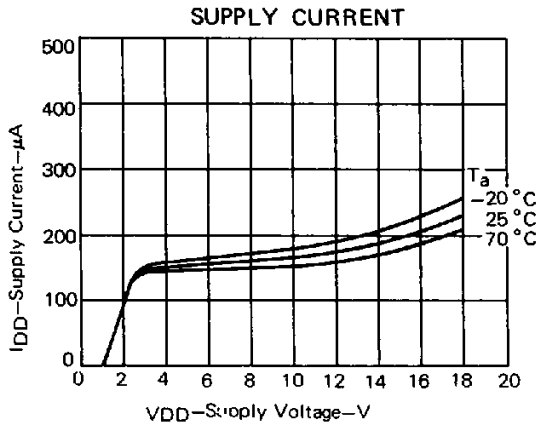

6427525 0070558 T66

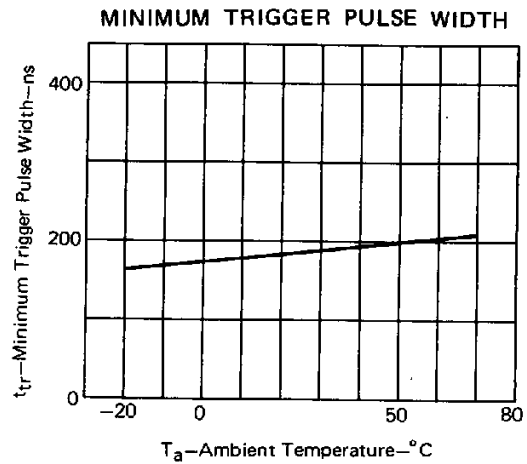
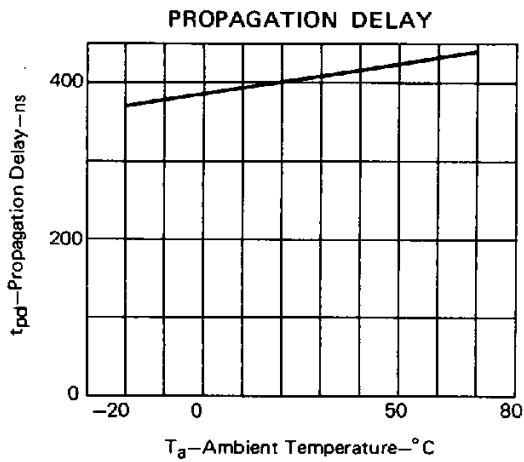
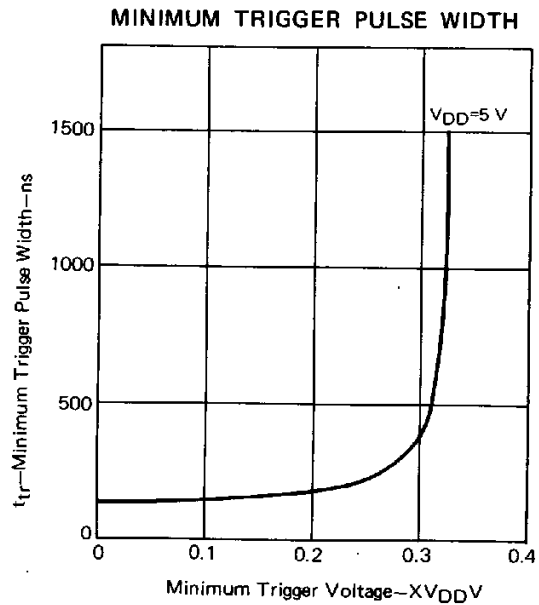
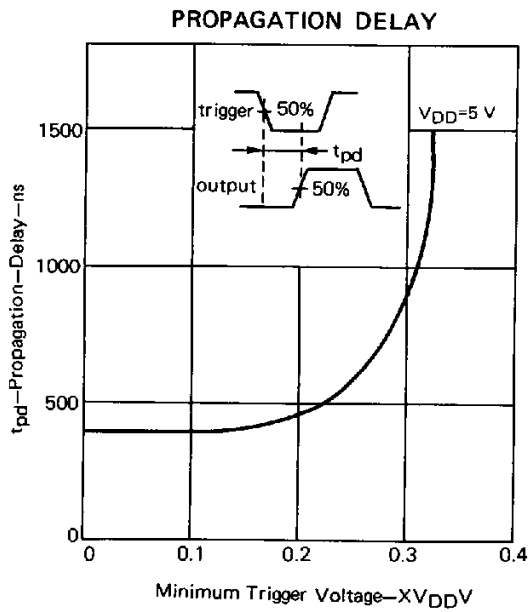
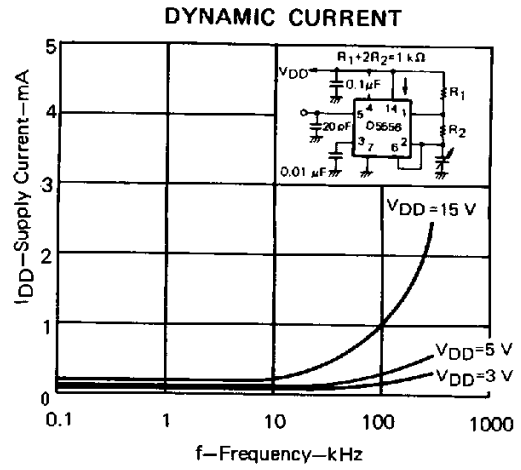
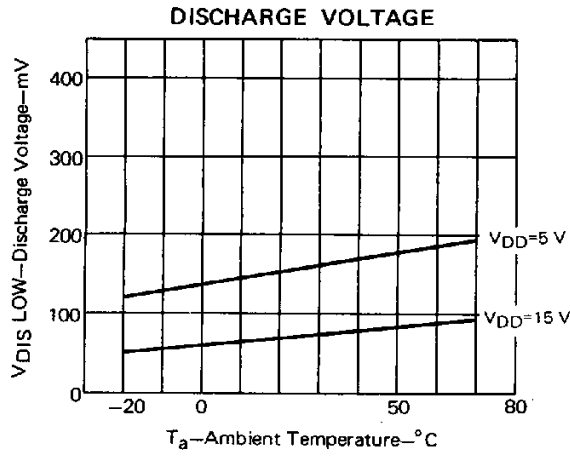

6427525 0070559 9T2

FREE RUNNING FREQUENCY

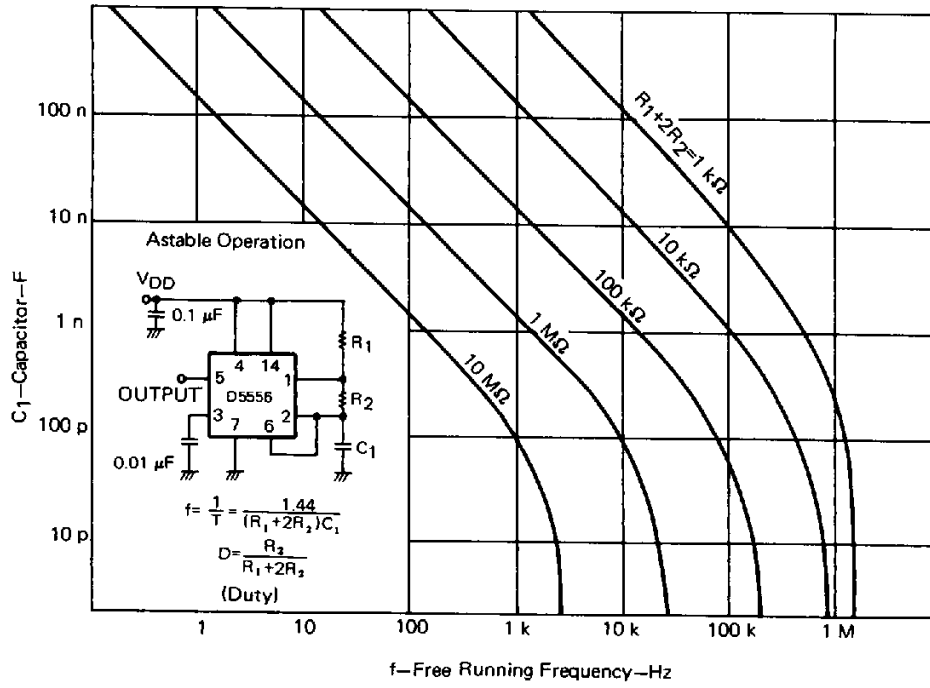

TIME DELAY

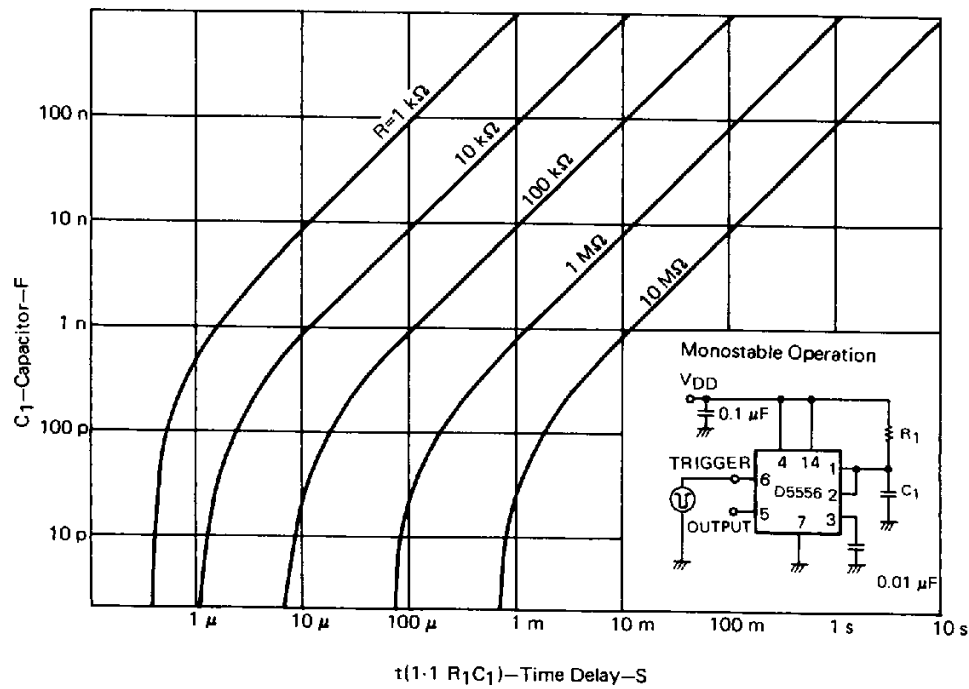

6427525 0070560 614

14PIN PLASTIC DIP (300 mil)

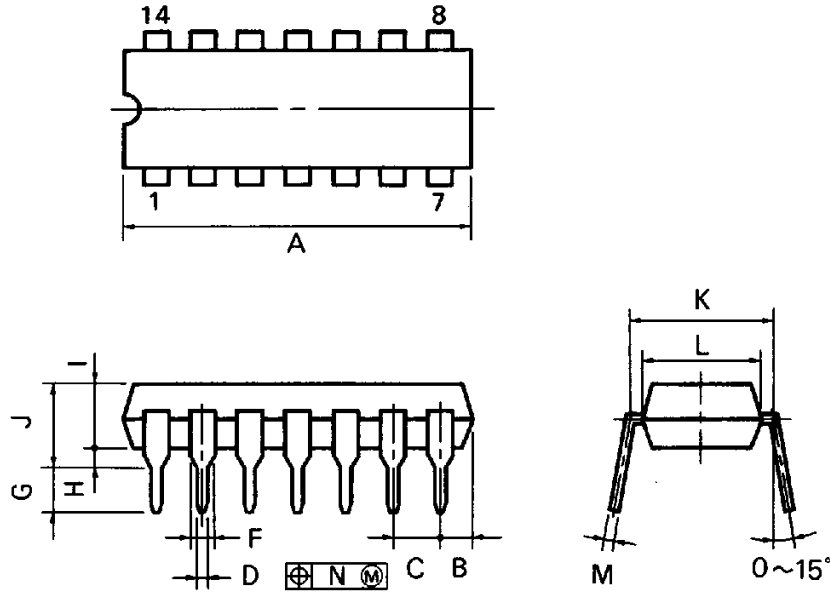

P14C-100-300B1

NOTES

- 1) Each lead centerline is located within 0.25 mm (0.01 inch) of its true position (T.P.) at maximum material condition.
- 2) Item "K" to center of leads when formed parallel.

ITEM	MILLIMETERS	INCHES
A	20.32 MAX.	0.800 MAX.
B	2.54 MAX.	0.100 MAX.
C	2.54 (T.P.)	0.100 (T.P.)
D	0.50 ^{+0.10}	0.020 ^{+0.004} _{-0.003}
F	1.2 MIN.	0.047 MIN.
G	3.6 ^{+0.3}	0.142 ^{+0.012}
H	0.51 MIN.	0.020 MIN.
I	4.31 MAX.	0.170 MAX.
J	5.08 MAX.	0.200 MAX.
K	7.62 (T.P.)	0.300 (T.P.)
L	6.4	0.252
M	0.25 ^{+0.10} _{-0.08}	0.010 ^{+0.004} _{-0.003}
N	0.25	0.01

6427525 0070561 550

14PIN PLASTIC SOP (225 mil)

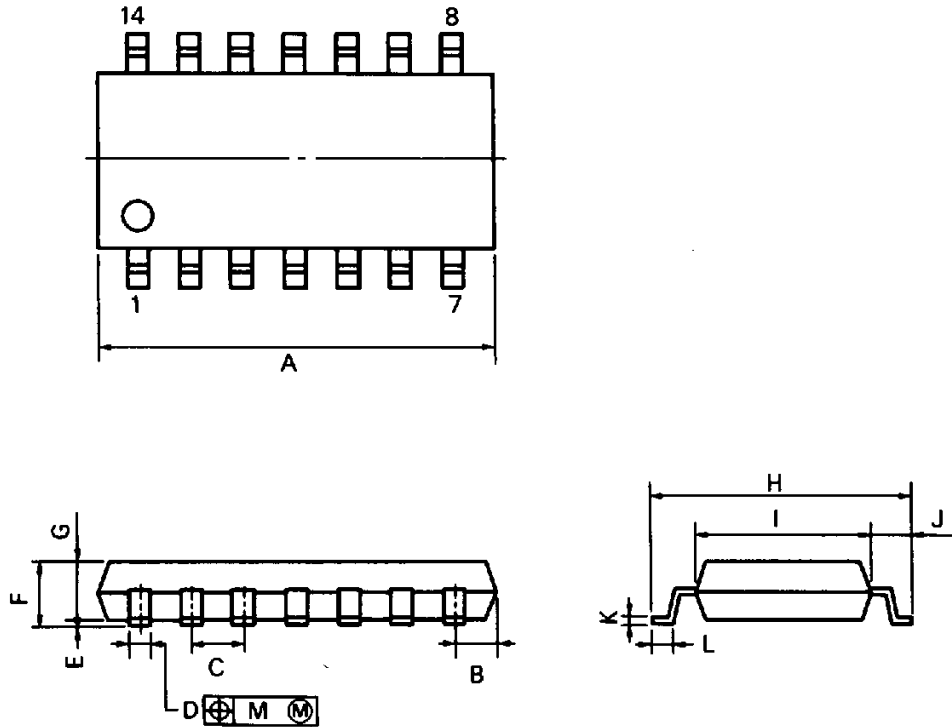

S14GM-50-225B, C

NOTE

Each lead centerline is located within 0.12 mm (0.005 inch) of its true position (T.P.) at maximum material condition.

ITEM	MILLIMETERS	INCHES
A	10.46 MAX.	0.412 MAX.
B	1.42 MAX.	0.056 MAX.
C	1.27 (T.P.)	0.050 (T.P.)
D	0.40 ^{+0.10} _{-0.08}	0.016 ^{+0.004} _{-0.003}
E	0.1 ^{±0.1}	0.004 ^{±0.004}
F	1.8 MAX.	0.071 MAX.
G	1.49	0.059
H	6.5 ^{±0.3}	0.256 ^{±0.012}
I	4.4	0.173
J	1.1	0.043
K	0.15 ^{+0.10} _{-0.08}	0.006 ^{+0.004} _{-0.002}
L	0.6 ^{±0.2}	0.024 ^{+0.008} _{-0.008}
M	0.12	0.005

IC-1993
May 1987P
Printed in Japan

6427525 0070562 497