

MITSUBISHI FAST RECOVERY DIODE MODULES
RM50DA/CA/C1A-XXS

MEDIUM POWER, HIGH FREQUENCY USE
 INSULATED TYPE

RM50DA/CA/C1A-XXS



- **IDC** DC current **50A**
- **VRRM** Repetitive peak reverse voltage
 **300/600V**
- **trr** Reverse recovery time **0.4μs**
- **Insulated Type**

APPLICATION

Free wheel use, Welder

OUTLINE DRAWING & CIRCUIT DIAGRAM

Dimensions in mm

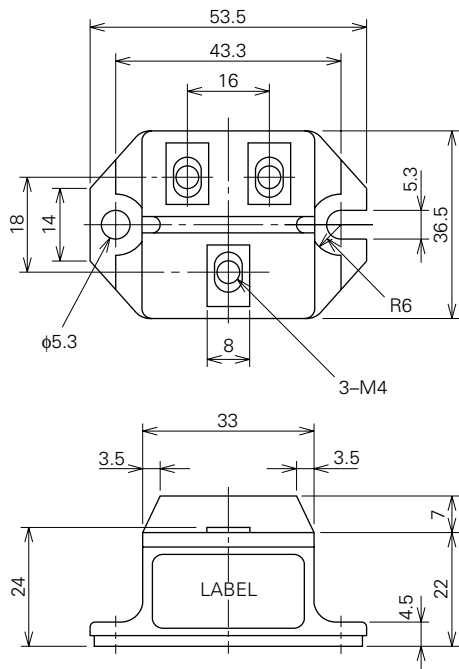

CA	
C1A	
DA	

Feb.1999



RM50DA/CA/C1A-XXS

MEDIUM POWER, HIGH FREQUENCY USE
INSULATED TYPE

ABSOLUTE MAXIMUM RATINGS (T_j=25°C, unless otherwise noted)

Symbol	Parameter	Voltage class		Unit
		6	12	
V _{RRM}	Repetitive peak reverse voltage	300	600	V
V _{DRM}	Non-repetitive peak reverse voltage	360	720	V
V _R	Reverse DC voltage	240	480	V

Symbol	Parameter	Conditions	Ratings	Unit
I _{DC}	DC current	Resistive load, T _c =93°C	50	A
I _{FSM}	Surge (non-repetitive) forward current	One half cycle at 60Hz, peak value	1000	A
I ² _t	I ² _t for fusing	Value for one cycle of surge current	4.2×10 ³	A ² s
T _j	Junction temperature		-40~150	°C
T _{stg}	Storage temperature		-40~125	°C
V _{iso}	Isolation voltage	Charged part to case	2500	V
—	Mounting torque	Main terminal screw M4	0.98~1.47	N·m
			10~15	kg·cm
		Mounting screw M5	1.47~1.96	N·m
			15~20	kg·cm
—	Weight	Typical value	90	g

ELECTRICAL CHARACTERISTICS

Symbol	Parameter	Test conditions	Limits			Unit
			Min.	Typ.	Max.	
I _{RRM}	Repetitive reverse current	T _j =150°C, V _{RRM} applied	—	—	20	mA
V _{FM}	Forward voltage	T _j =25°C, I _{FM} =50A, instantaneous meas.	—	1.7	1.8	V
t _{rr}	Reverse recovery time	I _{FM} =50A, di/dt=-100A/μs, V _R =150/300V*1, T _j =25°C	—	—	0.2	μs
Q _{rr}	Reverse recovery charge		—	—	1.5	μC
t _{rr}	Reverse recovery time	I _{FM} =50A, di/dt=-150A/μs, V _R =150/300V*1, T _j =150°C	—	—	0.4	μs
Q _{rr}	Reverse recovery charge		—	—	4.5	μC
R _{th(j-c)}	Thermal resistance	Junction to case	—	—	0.6	°C/W
R _{th(c-f)}	Contact thermal resistance	Case to fin, conductive grease applied	—	—	0.3	°C/W

*1 6 class: V_R=150V 12 class: V_R=300V

RM50DA/CA/C1A-XXS

MEDIUM POWER, HIGH FREQUENCY USE
INSULATED TYPE

PERFORMANCE CURVES

MAXIMUM FORWARD CHARACTERISTIC

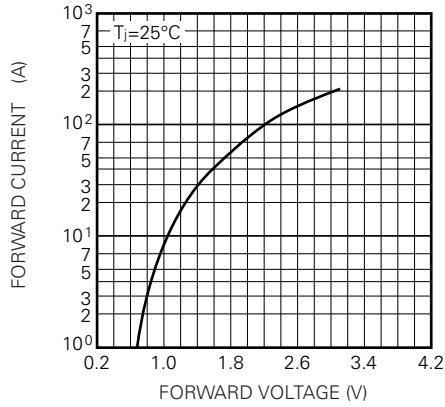

MAXIMUM TRANSIENT THERMAL IMPEDANCE (JUNCTION TO CASE)

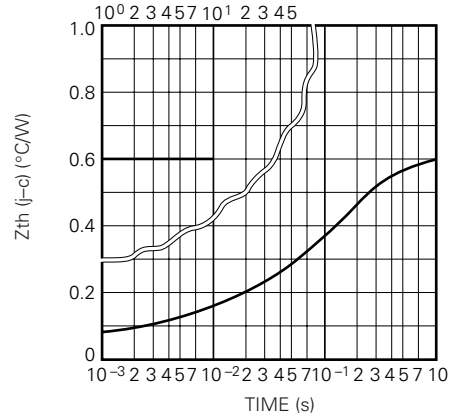

ALLOWABLE SURGE (NON-REPETITIVE) FORWARD CURRENT

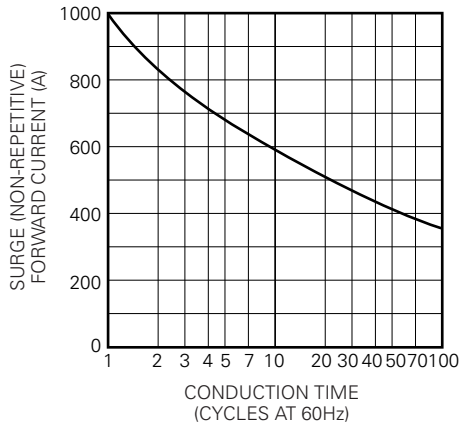

REVERSE RECOVERY CHARACTERISTICS VS. FORWARD CURRENT (TYPICAL)

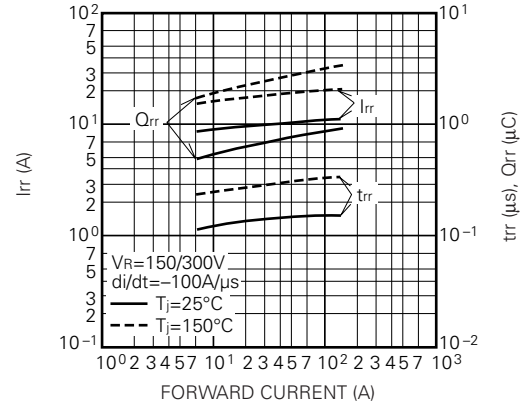

REVERSE RECOVERY CHARACTERISTICS VS. -di/dt (TYPICAL)

