



SFP+ Controller with Digital LDD Interface

DS1878

General Description

The DS1878 controls and monitors all functions for SFF, SFP, and SFP+ modules including all SFF-8472 functionality. The combination of the DS1878 with Maxim laser driver/limiting amplifier solutions supports VCSEL, DFB, and EML-based solutions. The device provides APC loop, modulation current control, and eye safety functionality. It continuously monitors for high output current, high bias current, and low and high transmit power to ensure that laser shutdown for eye safety requirements are met without adding external components. Six ADC channels monitor V_{CC} , temperature, and four external monitor inputs (MON1–MON4) that can be used to meet all monitoring requirements. MON3 is differential with support for common mode to V_{CC} . Two digital-to-analog (DAC) outputs with temperature-indexed lookup tables (LUTs) are available for additional control functionality.

Applications

SFF, SFP, and SFP+ Transceiver Modules

Ordering Information

PART	TEMP RANGE	PIN-PACKAGE
DS1878T+	-40°C to +95°C	28 TQFN-EP*
DS1878T+T&R	-40°C to +95°C	28 TQFN-EP*

+Denotes a lead(Pb)-free/RoHS-compliant package.

T&R = Tape and reel.

*EP = Exposed pad.

Features

- ◆ Meets All SFF-8472 Control and Monitoring Requirements
- ◆ Laser Bias Controlled by APC Loop and Temperature LUT to Compensate for Tracking Error
- ◆ Laser Modulation Controlled by Temperature LUT
- ◆ Six Analog Monitor Channels: Temperature, V_{CC} , MON1–MON4
MON1–MON4 Support Internal and External Calibration
Scalable Dynamic Range
Internal Direct-to-Digital Temperature Sensor
Alarm and Warning Flags for All Monitored Channels
- ◆ Two 9-Bit Delta-Sigma Outputs with 36 Entry Temperature LUTs
- ◆ Digital I/O Pins: Five Inputs, Four Outputs
- ◆ Comprehensive Fault-Measurement System with Maskable Laser Shutdown Capability
- ◆ Flexible, Two-Level Password Scheme Provides Three Levels of Security
- ◆ 256 Additional Bytes Located at A0h Slave Address
- ◆ I²C-Compatible Interface
- ◆ 3-Wire Master to Communicate with a Maxim Laser Driver/Limiting Amplifier
- ◆ +2.85V to +5.5V Operating Voltage Range
- ◆ -40°C to +95°C Operating Temperature Range
- ◆ 28-Pin TQFN (5mm x 5mm x 0.75mm) Package



SFP+ Controller with Digital LDD Interface

TABLE OF CONTENTS

Absolute Maximum Ratings	.5
Recommended Operating Conditions	.5
DC Electrical Characteristics	.5
DAC1, DAC2 Electrical Characteristics	.6
Analog Input Characteristics (MON2, TXP HI, TXP LO, HBIAS, LOS)	.6
Analog Voltage Monitoring Characteristics	.6
Digital Thermometer Characteristics	.7
AC Electrical Characteristics	.7
Control Loop and Quick-Trip Timing Characteristics	.7
3-Wire Digital Interface Specification	.7
I ² C AC Electrical Characteristics	.8
Nonvolatile Memory Characteristics	.8
Typical Operating Characteristics	.9
Pin Configuration	.10
Pin Description	.10
Block Diagram	.11
Typical Operating Circuit	.12
Detailed Description	.12
3-Wire DAC Control	.12
BIAS Register/APC Control, 3-Wire Mode	.13
MODULATION Control	.13
BIAS and MODULATION Control During Power-Up	.14
BIAS and MODULATION Registers as a Function of Transmit Disable (TXD)	.15
APC and Quick-Trip Timing	.15
Monitors and Fault Detection	.16
Monitors	.16
Five Quick-Trip Monitors and Alarms	.16
Six ADC Monitors and Alarms	.16
ADC Timing	.16
Right-Shifting ADC Result	.17
Enhanced RSSI Monitoring (Dual-Range Functionality)	.18
Low-Voltage Operation	.19
Power-On Analog (POA)	.20
Delta-Sigma Outputs (DAC1 and DAC2)	.20
Digital I/O Pins	.21
LOS, LOSOUT	.21
IN1, RSEL, RSELOUT	.21
TXD, TXDOUT	.21
Transmit Fault (TXFOUT) Output	.22

SFP+ Controller with Digital LDD Interface

DS1878

TABLE OF CONTENTS (continued)

Die Identification	.23
3-Wire Master for Controlling the Maxim Laser Driver and Limiting Amplifier	.23
Protocol	.23
3-Wire Interface Timing	.24
DS1878 Master Communication Interface	.24
Normal Operation	.24
Manual Operation	.24
Initialization	.24
Slave Register Map and DS1878 Corresponding Location	.25
I ² C Communication	.27
I ² C Definitions	.27
I ² C Protocol	.28
Memory Organization	.29
Shadowed EEPROM	.30
Register Descriptions	.31
Lower Memory Register Map	.31
Table 01h Register Map	.32
Table 02h Register Map	.33
Table 04h Register Map	.34
Table 05h Register Map	.34
Table 06h Register Map	.34
Table 07h Register Map	.35
Table 08h Register Map	.35
Auxiliary A0h Memory Register Map	.35
Lower Memory Register Descriptions	.36
Table 01h Register Descriptions	.50
Table 02h Register Descriptions	.57
Table 04h Register Description	.93
Table 06h Register Descriptions	.94
Table 07h Register Descriptions	.95
Table 08h Register Descriptions	.96
Auxiliary Memory A0h Register Description	.97
Applications Information	.97
Power-Supply Decoupling	.97
SDA and SCL Pullup Resistors	.97
Package Information	.97
Revision History	.98

SFP+ Controller with Digital LDD Interface

LIST OF FIGURES

Figure 1. Modulation LUT Loading to a Maxim Laser Driver MOD DAC	.13
Figure 2. Power-Up Timing	.14
Figure 3. TXD Timing	.15
Figure 4. APC Loop and Quick-Trip Sample Timing	.15
Figure 5. ADC Round-Robin Timing	.17
Figure 6. MON2 V _{CC} or GND Reference	.17
Figure 7. MON3 Differential Input for High-Side RSSI	.17
Figure 8. RSSI with Crossover Enabled	.18
Figure 9. RSSI with Crossover Disabled	.19
Figure 10. Low-Voltage Hysteresis Example	.19
Figure 11. Recommended RC Filter for DAC1/DAC2	.20
Figure 12. Delta-Sigma Outputs	.20
Figure 13. DAC1/DAC2 LUT Assignments	.21
Figure 14. Logic Diagram 1	.22
Figure 15. Logic Diagram 2	.22
Figure 16a. TXFOUT Nonlatched Operation	.23
Figure 16b. TXFOUT Latched Operation	.23
Figure 17. 3-Wire Timing	.24
Figure 18. 3-Wire State Machine	.26
Figure 19. I ² C Timing	.27
Figure 20. Example I ² C Timing	.29
Figure 21. Memory Map	.30

LIST OF TABLES

Table 1. Acronyms	.13
Table 2. Update Rate Timing	.15
Table 3. ADC Default Monitor Full-Scale Ranges	.16
Table 4. MON3 Hysteresis Threshold Values	.18
Table 5. MON3 Configuration Registers	.18

SFP+ Controller with Digital LDD Interface

ABSOLUTE MAXIMUM RATINGS

Voltage Range on MON1–MON4, RSEL, CSEL1OUT, CSEL2OUT, SCLOUT, SDAOUT, TXDOUT, IN1, LOS, TXF, TXFOUT, and TXD Pins Relative to Ground-0.5V to (V_{CC} + 0.5V)*
 Voltage Range on V_{CC}, SDA, SCL, RSELOUT, and LOSOUT Pins Relative to Ground-0.5V to +6V
 *Subject to not exceeding +6V.

Continuous Power Dissipation (T_A = +70°C)
 28 Pin TQFN (derate 34.5mW/°C above +70°C)2758.6mW
 Operating Temperature Range-40°C to +95°C
 Programming Temperature Range0°C to +95°C
 Storage Temperature Range-55°C to +125°C
 Lead Temperature (soldering, 10s)+300°C
 Soldering Temperature (reflow)+260°C

Stresses beyond those listed under "Absolute Maximum Ratings" may cause permanent damage to the device. These are stress ratings only, and functional operation of the device at these or any other conditions beyond those indicated in the operational sections of the specifications is not implied. Exposure to absolute maximum rating conditions for extended periods may affect device reliability.

RECOMMENDED OPERATING CONDITIONS

(T_A = -40°C to +95°C, unless otherwise noted.)

PARAMETER	SYMBOL	CONDITIONS	MIN	TYP	MAX	UNITS
Main Supply Voltage	V _{CC}	(Note 1)	2.85		5.5	V
High-Level Input Voltage (SDA, SCL, SDAOUT)	V _{IH:1}		0.7 x V _{CC}		V _{CC} + 0.3	V
Low-Level Input Voltage (SDA, SCL, SDAOUT)	V _{IL:1}		-0.3		0.3 x V _{CC}	V
High-Level Input Voltage (TXD, TXF, RSEL, IN1, LOS)	V _{IH:2}		2.0		V _{CC} + 0.3	V
Low-Level Input Voltage (TXD, TXF, RSEL, IN1, LOS)	V _{IL:2}		-0.3		+0.8	V

DC ELECTRICAL CHARACTERISTICS

(V_{CC} = +2.85V to +5.5V, T_A = -40°C to +95°C, unless otherwise noted.)

PARAMETER	SYMBOL	CONDITIONS	MIN	TYP	MAX	UNITS
Supply Current	I _{CC}	(Notes 1, 2)		2.5	4	mA
Output Leakage (SDA, SDAOUT, RSELOUT, LOSOUT, TXFOUT)	I _{LO}				1	µA
Low-Level Output Voltage (SDA, SDAOUT, SCLOUT, CSEL1OUT, CSEL2OUT, RSELOUT, LOSOUT, TXDOUT, DAC1, DAC2, TXFOUT)	V _{OL}	I _{OL} = 4mA			0.4	V
		I _{OL} = 6mA			0.6	
High-Level Output Voltage (DAC1, DAC2, SCLOUT, SDAOUT, CSEL1OUT, CSEL2OUT, TXDOUT)	V _{OH}	I _{OH} = 4mA	V _{CC} - 0.4			V
TXDOUT Before EEPROM Recall		High impedance before recall	55	550	100	MΩ
DAC1 and DAC2 Before Recall						
Input Leakage Current (IN1, LOS, RSEL, SCL, TXD, TXF)	I _{LI}				1	µA
Digital Power-On Reset	POD		1.0		2.2	V
Analog Power-On Reset	POA		2.0		2.75	V

SFP+ Controller with Digital LDD Interface

DAC1, DAC2 ELECTRICAL CHARACTERISTICS

($V_{CC} = +2.85V$ to $+5.5V$, $T_A = -40^{\circ}C$ to $+95^{\circ}C$, unless otherwise noted.)

PARAMETER	SYMBOL	CONDITIONS	MIN	TYP	MAX	UNITS
Main Oscillator Frequency	f _{OSC}			5		MHz
Delta-Sigma Input-Clock Frequency	f _{DS}			1.25		MHz
Reference Voltage Input (REFIN)	V _{REFIN}	Minimum 0.1 μ F to GND	2		V _{CC}	V
Output Range			0		V _{REFIN}	V
Output Resolution		See the <i>Delta-Sigma Outputs (DAC1 and DAC2)</i> section for details			9	Bits
Output Impedance	R _{DS}			35	100	Ω

ANALOG INPUT CHARACTERISTICS (MON2, TXP HI, TXP LO, HBIAS, LOS)

($V_{CC} = +2.85V$ to $+5.5V$, $T_A = -40^{\circ}C$ to $+95^{\circ}C$, unless otherwise noted.)

PARAMETER	SYMBOL	CONDITIONS	MIN	TYP	MAX	UNITS
MON2, TXP HI, TXP LO, HBIAS, LOS Full-Scale Voltage		(Note 3)		1.25		V
MON2 Input Resistance			35	50	65	k Ω
Resolution		(Note 3)		8		Bits
Error		$T_A = +25^{\circ}C$ (Note 4)		± 2		%FS
Integral Nonlinearity			-1		+1	LSB
Differential Nonlinearity			-1		+1	LSB
Temperature Drift			-2.5		+2.5	%FS

ANALOG VOLTAGE MONITORING CHARACTERISTICS

($V_{CC} = +2.85V$ to $+5.5V$, $T_A = -40^{\circ}C$ to $+95^{\circ}C$, unless otherwise noted.)

PARAMETER	SYMBOL	CONDITIONS	MIN	TYP	MAX	UNITS
ADC Resolution				13		Bits
Input/Supply Accuracy (MON1–MON4, V _{CC})	ACC	At factory setting		0.25	0.5	%FS
Sample Rate for Temperature, MON1–MON4, and V _{CC}	t _{RR}			64	75	ms
Input/Supply Offset (MON1–MON4, V _{CC})	V _{OS}	(Note 5)		0	5	LSB
Factory Setting Full-Scale (Note 6)		MON1–MON4		2.5		V
		V _{CC}		6.5536		
		MON3 Fine		312.5		μ V

SFP+ Controller with Digital LDD Interface

DIGITAL THERMOMETER CHARACTERISTICS

($V_{CC} = +2.85V$ to $+5.5V$, $T_A = -40^{\circ}C$ to $+95^{\circ}C$, unless otherwise noted.)

PARAMETER	SYMBOL	CONDITIONS	MIN	TYP	MAX	UNITS
Thermometer Error	T_{ERR}	$-40^{\circ}C$ to $+95^{\circ}C$	-3		+3	$^{\circ}C$

AC ELECTRICAL CHARACTERISTICS

($V_{CC} = +2.85V$ to $+5.5V$, $T_A = -40^{\circ}C$ to $+95^{\circ}C$, unless otherwise noted.)

PARAMETER	SYMBOL	CONDITIONS	MIN	TYP	MAX	UNITS
TXD Enable	t_{OFF}	From rising TXD to rising TXDOUT			5	μs
Recovery from TXD Disable	t_{ON}	From falling TXD to falling TXDOUT			5	μs
Fault Reset Time (to TXFOUT = 0)	t_{INTR1}	From falling TXD		131		ms
	t_{INTR2}	On power-up or falling TXD, when VCC LO alarm is detected (Note 7)		161		
Fault Assert Time (to TXFOUT = 1)	t_{FAULT}	After HTXP, LTXP, HBATH, IBIASMAX (Note 8)	6.4		55	μs
LOSOUT Assert Time	t_{LOSS_ON}	LLOS (Notes 8, 9)	6.4		55	μs
LOSOUT Deassert Time	t_{LOSS_OFF}	HLOS (Notes 8, 10)	6.4		55	μs

CONTROL LOOP AND QUICK-TRIP TIMING CHARACTERISTICS

($V_{CC} = +2.85V$ to $+5.5V$, $T_A = -40^{\circ}C$ to $+95^{\circ}C$, unless otherwise noted.)

PARAMETER	SYMBOL	CONDITIONS	MIN	TYP	MAX	UNITS
Output-Enable Time Following POA	t_{INIT}	(Note 7)		20		ms
Binary Search Time	t_{SEARCH}	(Note 11)	8		10	BIAS Samples

3-WIRE DIGITAL INTERFACE SPECIFICATION

($V_{CC} = +2.85V$ to $+5.5V$, $T_A = -40^{\circ}C$ to $+95^{\circ}C$, timing referenced to $V_{IL(MAX)}$ and $V_{IH(MIN)}$, unless otherwise noted.) (Figure 17)

PARAMETER	SYMBOL	CONDITIONS	MIN	TYP	MAX	UNITS
SCLOUT Clock Frequency	f_{SCLOUT}			833		kHz
SCLOUT Duty Cycle	t_{3WDC}			50		%
SDAOUT Setup Time	t_{DS}		100			ns
SDAOUT Hold Time	t_{DH}		100			ns
CSEL1OUT, CSEL2OUT Pulse-Width Low	t_{CSW}		500			ns
CSEL1OUT, CSEL2OUT Leading Time Before the First SCLOUT Edge	t_L		500			ns
CSEL1OUT, CSEL2OUT Trailing Time After the Last SCLOUT Edge	t_T		500			ns
SDAOUT, SCLOUT Load	C_{B3W}	Total bus capacitance on one line			10	pF

SFP+ Controller with Digital LDD Interface

I²C AC ELECTRICAL CHARACTERISTICS

(V_{CC} = +2.85V to +5.5V, T_A = -40°C to +95°C, timing referenced to V_{IL(MAX)} and V_{IH(MIN)}, unless otherwise noted.) (Figure 19)

PARAMETER	SYMBOL	CONDITIONS	MIN	TYP	MAX	UNITS
SCL Clock Frequency	f _{SCL}	(Note 12)	0		400	kHz
Clock Pulse-Width Low	t _{LOW}		1.3			μs
Clock Pulse-Width High	t _{HIGH}		0.6			μs
Bus-Free Time Between STOP and START Condition	t _{BUF}		1.3			μs
START Hold Time	t _{HD:STA}		0.6			μs
START Setup Time	t _{SU:STA}		0.6			μs
Data In Hold Time	t _{HD:DAT}		0		0.9	μs
Data In Setup Time	t _{SU:DAT}		100			ns
Rise Time of Both SDA and SCL Signals	t _R	(Note 13)	20 + 0.1C _B		300	ns
Fall Time of Both SDA and SCL Signals	t _F	(Note 13)	20 + 0.1C _B		300	ns
STOP Setup Time	t _{SU:STO}		0.6			μs
Capacitive Load for Each Bus Line	C _B				400	pF
EEPROM Write Time	t _{WR}	(Note 14)			20	ms

NONVOLATILE MEMORY CHARACTERISTICS

(V_{CC} = +2.85V to +5.5V, unless otherwise noted.)

PARAMETER	SYMBOL	CONDITIONS	MIN	TYP	MAX	UNITS
EEPROM Write Cycles		At +25°C	200,000			
		At +85°C	50,000			

- Note 1:** All voltages are referenced to ground. Current into the IC is positive, and current out of the IC is negative.
- Note 2:** Inputs are at supply rail. Outputs are not loaded.
- Note 3:** Eight ranges allow the full-scale range to change from 312mV to 1.25V.
- Note 4:** The output impedance of the device is proportional to its scale setting. For instance, if using the 1/2 scale, the output impedance is 1.5kΩ.
- Note 5:** This parameter is guaranteed by design.
- Note 6:** Full-scale is programmable.
- Note 7:** A temperature conversion is completed and the MODULATION register value is recalled from the LUT and V_{CC} has been measured to be above the VCC LO alarm.
- Note 8:** The timing is determined by the choice of the SAMPLE RATE setting (see Table 02h, Register 88h).
- Note 9:** This specification is the time it takes from MON3 voltage falling below the LLOS trip threshold to LOSOUT asserted high.
- Note 10:** This specification is the time it takes from MON3 voltage rising above the HLOS trip threshold to LOSOUT asserted low.
- Note 11:** Assuming an appropriate initial step is programmed that would cause the power to exceed the APC set point within four steps, the bias current will be within 3% within the time specified by the binary search time. See the *BIAS and MODULATION Control During Power-Up* section.
- Note 12:** I²C interface timing shown is for fast-mode (400kHz) operation. This device is also backward compatible with I²C standard-mode timing.
- Note 13:** C_B—the total capacitance of one bus line in pF.
- Note 14:** EEPROM write begins after a STOP condition occurs.

SFP+ Controller with Digital LDD Interface

Typical Operating Characteristics

($V_{CC} = +2.85V$ to $+3.9V$, $T_A = +25^\circ C$, unless otherwise noted.)

DS1878

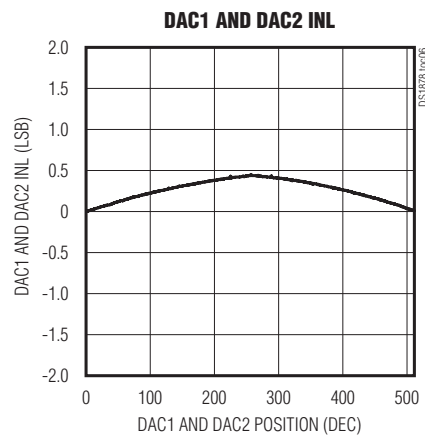
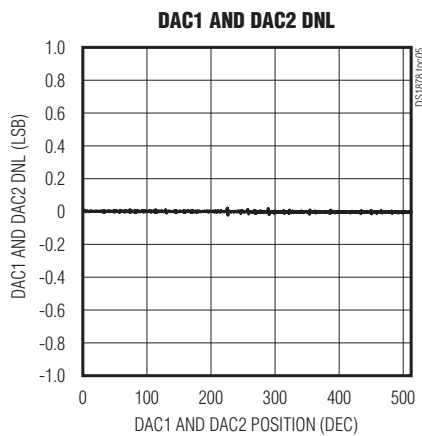
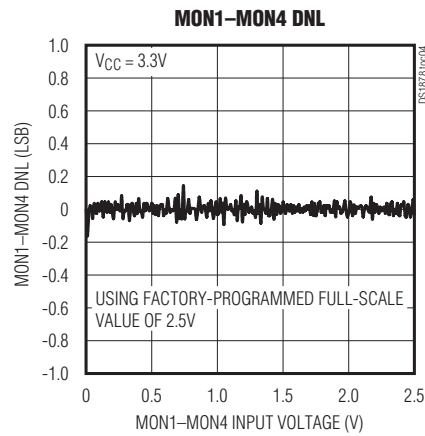
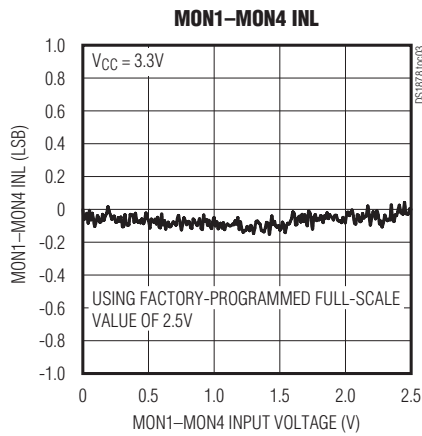
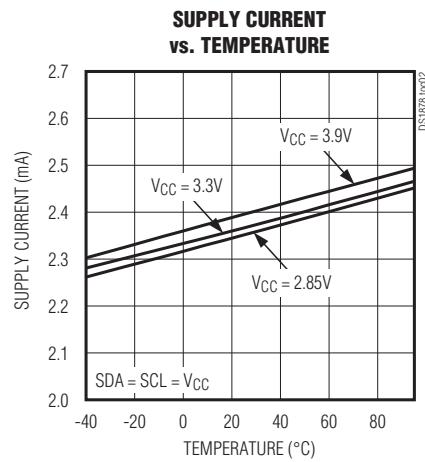
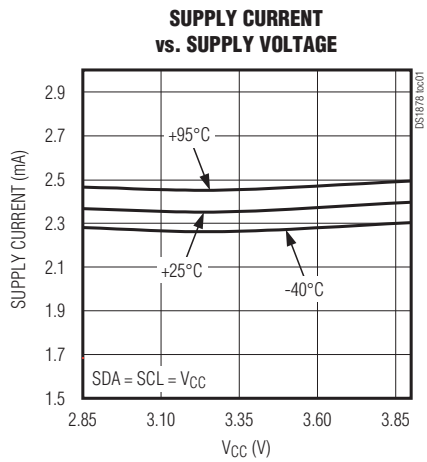

SFP+ Controller with Digital LDD Interface

Pin Configuration

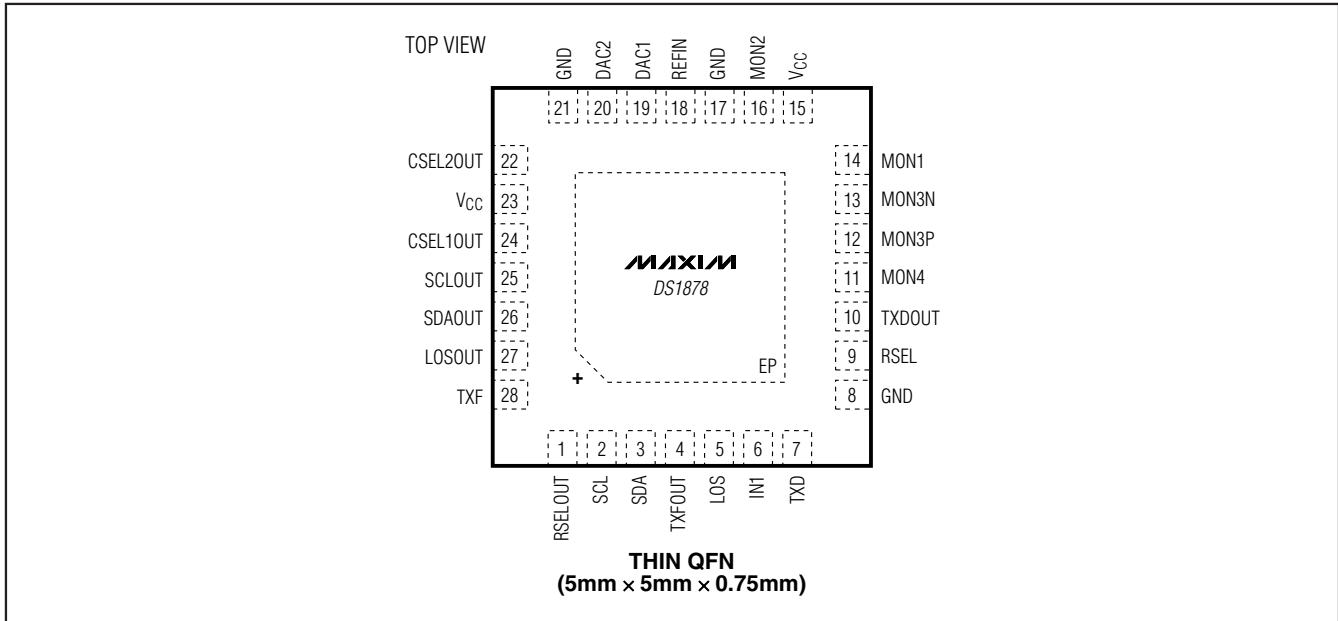

Pin Description

PIN	NAME	FUNCTION
1	RSELOUT	Rate-Select Output
2	SCL	I ² C Serial-Clock Input
3	SDA	I ² C Serial-Data Input/Output
4	TXFOUT	Transmit Fault Output, Open Drain
5	LOS	Loss of Signal Input
6	IN1	Digital Input. General-purpose input, AS1 in SFF-8079, or RS1 in SFF-8431.
7	TXD	Transmit Disable Input
8, 17, 21	GND	Ground Connection
9	RSEL	Rate-Select Input
10	TXDOUT	Transmit Disable Output
11	MON4	External Monitor Input 4
12, 13	MON3P, MON3N	Differential External Monitor Input 3 and LOS Quick Trip
14	MON1	External Monitor Input 1 and HBATH Quick Trip
15, 23	VCC	Power-Supply Input
16	MON2	External Monitor Input 2, Feedback Voltage for APC Loop, and TXP HI/TXP LO Quick Trip

PIN	NAME	FUNCTION
18	REFIN	Reference Input for DAC1 and
19	DAC1	Delta-Sigma Output 1
20	DAC2	Delta-Sigma Output 2
22	CSEL2OUT	Chip-Select Output 2. Part of 3-wire interface to a laser driver/limiting amplifier.
24	CSEL1OUT	Chip-Select Output 1. Part of 3-wire interface to a laser driver/limiting amplifier.
25	SCLOUT	Serial-Clock Output. Part of 3-wire interface to a laser driver/limiting amplifier.
26	SDAOUT	Serial-Data Input/Output. Part of 3-wire interface to a laser driver/limiting amplifier.
27	LOSOUT	Receive Loss-of-Signal Output
28	TXF	Transmit Fault Input
—	EP	Exposed Pad. Connect to ground.

SFP+ Controller with Digital LDD Interface

Block Diagram

DS1878

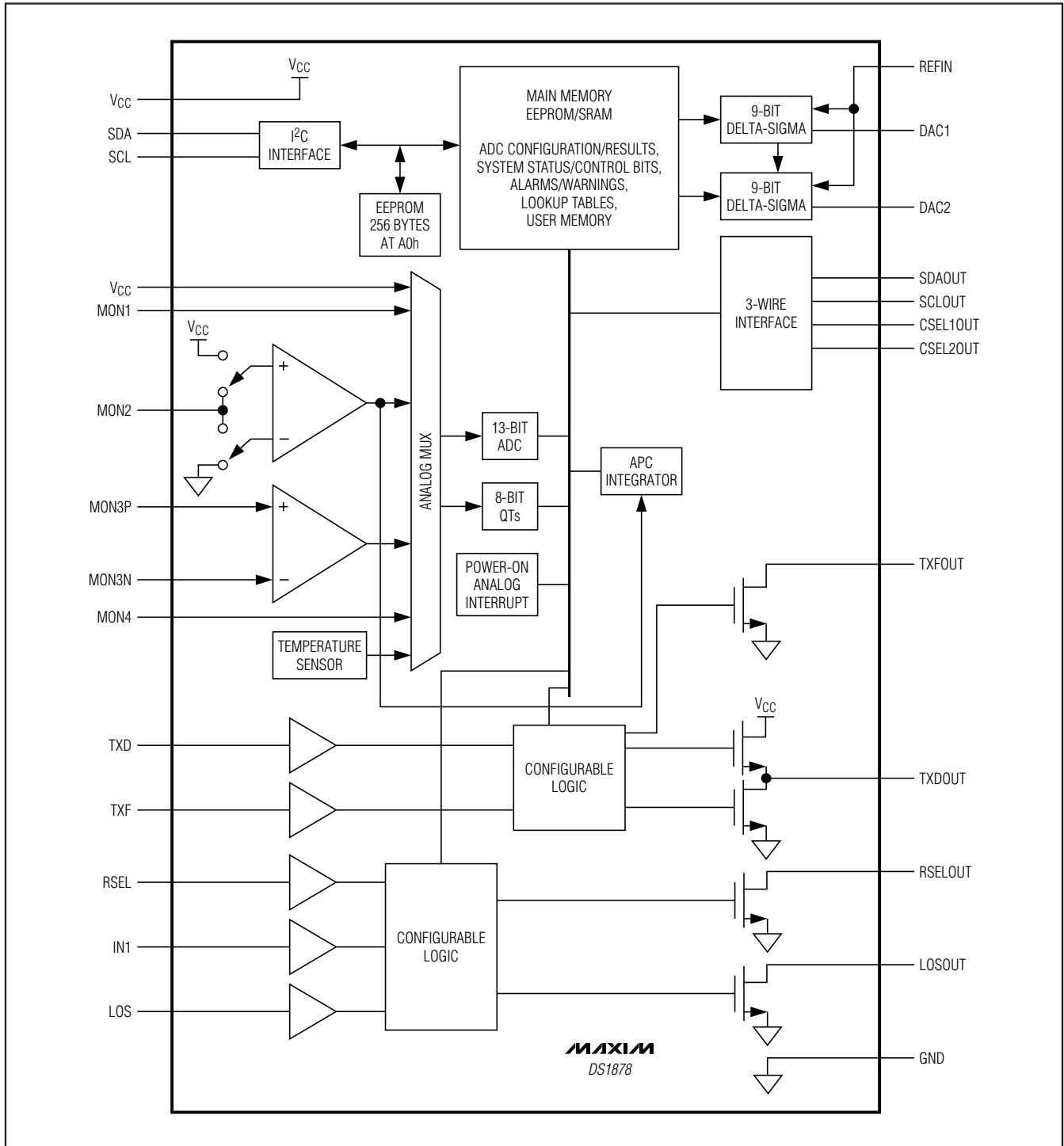

SFP+ Controller with Digital LDD Interface

Typical Operating Circuit

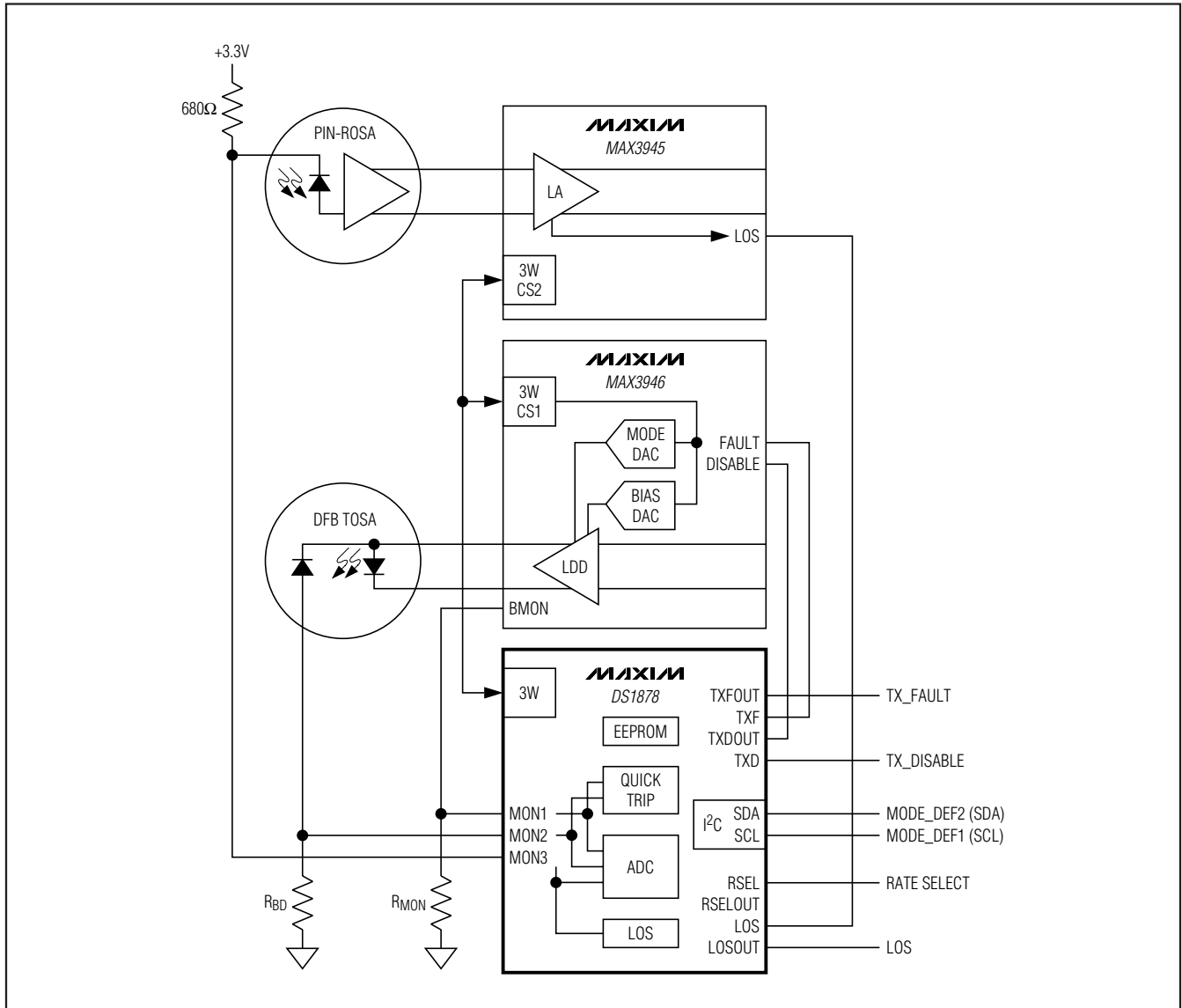

Detailed Description

The DS1878 integrates the control and monitoring functionality required to implement a VCSEL-based or DFB-based SFP or SFP+ system using Maxim's limiting amplifiers and laser drivers. Key components of the device are shown in the *Block Diagram* and described in subsequent sections.

3-Wire DAC Control

The device controls two 9-bit DACs inside the Maxim laser drivers. One DAC is used for laser bias control, while the other is used for modulation amplitude control. The device communicates with the laser driver over a 3-wire digital interface (see the *3-Wire Master for Controlling the Maxim Laser Driver* section). The communication between the device and Maxim laser driver and/or limiting amplifier is transparent to the end user.

SFP+ Controller with Digital LDD Interface

Table 1. Acronyms

ACRONYM	DEFINITION
ADC	Analog-to-Digital Converter
AGC	Automatic Gain Control
APC	Automatic Power Control
APD	Avalanche Photodiode
ATB	Alarm Trap Bytes
BM	Burst Mode
DAC	Digital-to-Analog Converter
DFB	Distributed Feedback Laser
LDD	Laser Diode Driver
LOS	Loss of Signal
LUT	Lookup Table
NV	Nonvolatile
QT	Quick Trip
TE	Tracking Error
TIA	Transimpedance Amplifier
ROSA	Receiver Optical Subassembly
SEE	Shadowed EEPROM
SFF	Small Form Factor
SFF-8472	Document Defining Register Map of SFPs and SFFs
SFP	Small Form Factor Pluggable
SFP+	Enhanced SFP
TOSA	Transmit Optical Subassembly
TXP	Transmit Power
VCSEL	Vertical Cavity Self-Emitting Laser

BIAS Register/APC Control, 3-Wire Mode

A Maxim laser driver controls its laser bias current DAC using the APC loop within the device. The APC loop's feedback to the device is the monitor diode (MON2) current, which is converted to a voltage using an external resistor. The feedback is sampled by a comparator and compared to a digital set-point value. The output of the comparator has three states: up, down, or no-operation. The no-operation state prevents the output from excessive toggling once steady state is reached. As long as the comparator output is in either the up or down states, the bias is adjusted by writing increment and decrement values to the Maxim laser driver through the BIASINC register.

The device has an LUT to allow the APC set point to change as a function of temperature to compensate for tracking error (TE). The APC LUT has 36 entries that determine the APC setting in 4°C windows between -40°C and +100°C.

MODULATION Control

A Maxim laser driver controls the laser modulation using the internal temperature-indexed LUT within the device. The modulation LUT is programmed in 2°C increments over the -40°C to +102°C range to provide temperature compensation for the laser's modulation. The modulation is updated after each temperature conversion using the 3-wire interface that connects to the Maxim laser driver. A Maxim laser driver include a 9-bit DAC. The modulation LUT is 8 bits.

Figure 1 demonstrates how the 8-bit LUT controls the 9-bit DAC with the use of a temperature control bit

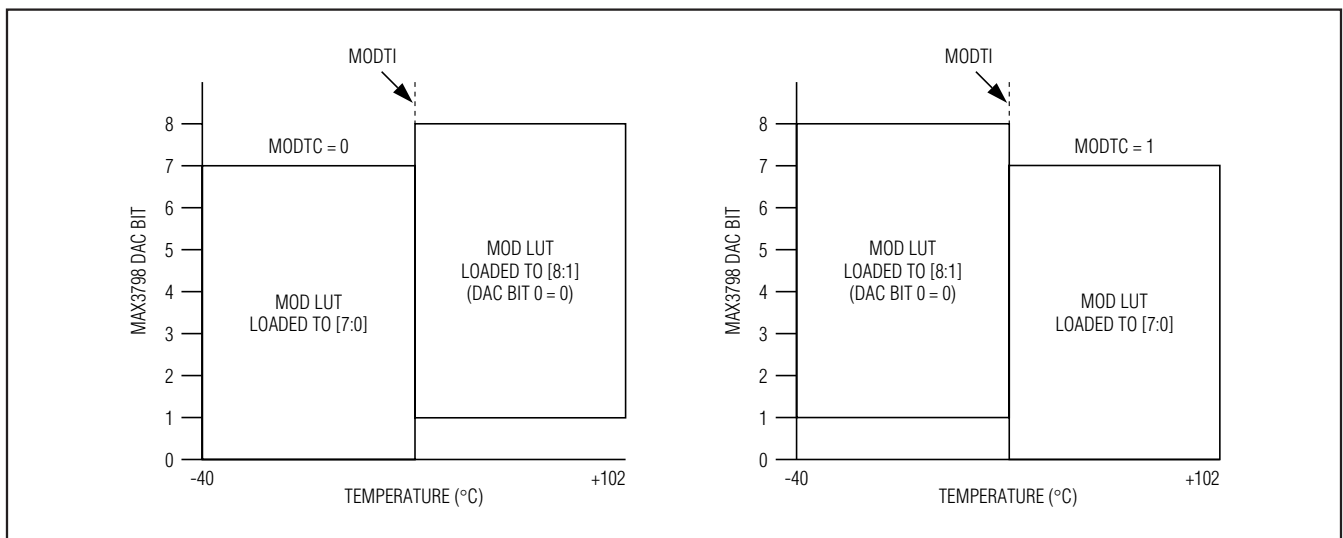

Figure 1. Modulation LUT Loading to a Maxim Laser Driver MOD DAC

SFP+ Controller with Digital LDD Interface

(MODTC, Table 02h, Register C6h) and a temperature index register (MODTI, Table 02h, Register C2h).

BIAS and MODULATION Control During Power-Up

The device has two internal registers, MODULATION and BIAS, that represent the values written to the Maxim laser driver's modulation DAC and bias DAC through the 3-wire interface. On power-up, the device sets the MODULATION and BIAS registers to 0. When V_{CC} is above POA, the device initializes the Maxim laser driver. After a temperature conversion is completed and if the VCC LO alarm is enabled, an additional VCC conversion above the customer-defined VCC LO alarm level is required before a Maxim laser driver MODULATION register is updated with the value determined by the temperature conversion and the modulation LUT.

When the MODULATION register is set, the BIAS register is set to a value equal to ISTEP (see Figure 2). The startup algorithm verifies whether this bias current causes a feedback voltage above the APC set point, and if not, it continues increasing the BIAS register by ISTEP until the APC set point is exceeded. When the APC set point is exceeded, the device begins a binary search to quickly reach the bias current corresponding to the proper power level. After the binary search is completed, the APC integrator is enabled and single LSB steps are used to tightly control the average power.

The TXP HI, TXP LO, and BIAS MAX QT alarms are masked until the binary search is completed. However, the BIAS MAX alarm is monitored during this time to prevent the BIAS register from exceeding IBIASMAX. During the bias current initialization, the BIAS register is not allowed to exceed IBIASMAX. If this occurs during the ISTEP sequence, then the binary search routine is enabled. If IBIASMAX is exceeded during the binary search, the next smaller step is activated. ISTEP or binary increments that would cause the BIAS register to exceed IBIASMAX are not taken. Masking the alarms until the completion of the binary search prevents false positive alarms during startup.

ISTEP is a value controlled by registers ISTEPH, ISTEPL, and ISTEPTI (Table 02h, Registers BAh, BBh, and C5h, respectively). See the register descriptions for more information. During the first steps, a Maxim laser driver's bias DAC is directly written using SET_IBIAS. ISTEP should be programmed to the maximum safe increase that is allowable during startup. If this value is programmed too low, the device still operates, but it could take significantly longer for the algorithm to converge and hence to control the average power.

If a fault is detected, and TXD is toggled to reenable the outputs, the device powers up following a similar sequence to an initial power-up. The only difference is that the device already has determined the present

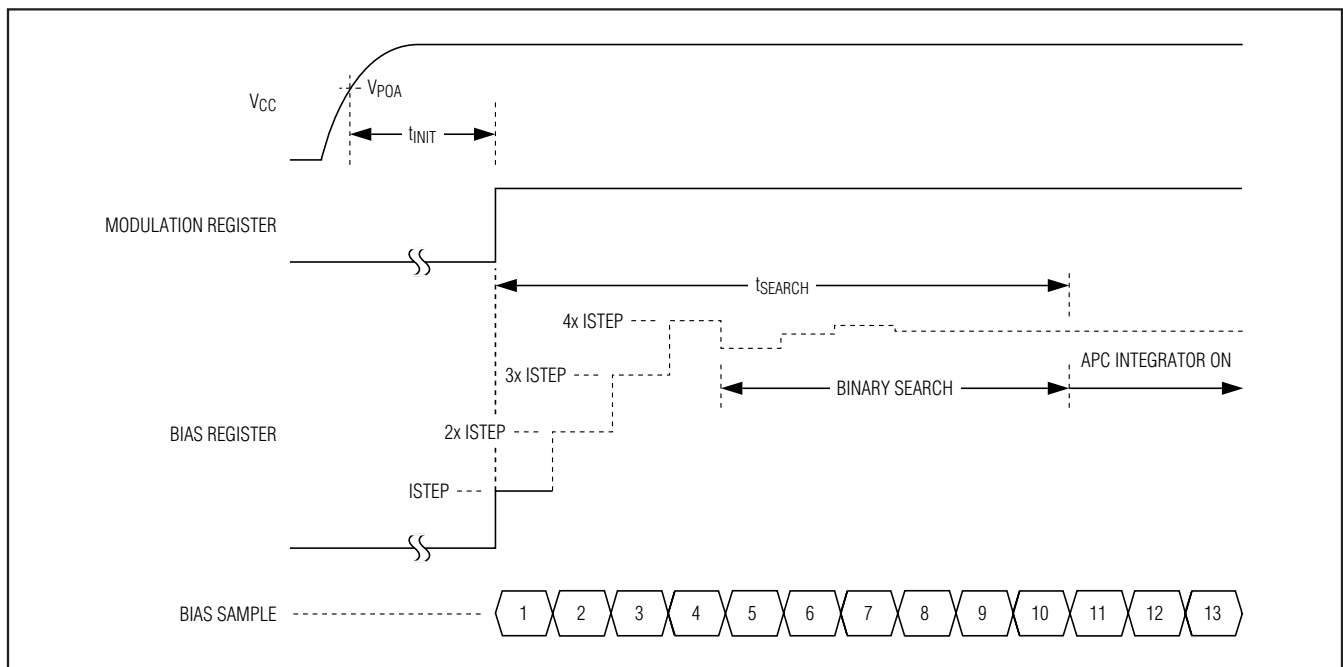

Figure 2. Power-Up Timing

SFP+ Controller with Digital LDD Interface

temperature, so the t_{INIT} time is not required for the device to recall the APC and MOD set points from EEPROM.

BIAS and MODULATION Registers as a Function of Transmit Disable (TXD)

If TXD is asserted (logic 1) during normal operation, the 3-wire master writes the laser driver bias and MODULATION DACs to 0. When TXD is deasserted (logic 0), the device sets the MODULATION register with the value associated with the present temperature, and initializes the BIAS register using the same search algorithm as done at startup. When asserted, soft TXD (TXDC) (Lower Memory, Register 6Eh) would allow a software control identical to the TXD pin (see Figure 3).

APC and Quick-Trip Timing

As shown in Figure 4, the device's input comparator is shared between the APC control loop and the quick-trip alarms (TXP HI, TXP LO, LOS, BIAS HI, and IBIAS MAX). The comparator polls the alarms in a multiplexed sequence. Five of every eight comparator readings are used for APC loop bias-current control. The other three updates are used to check the HTXP/LTXP (monitor diode voltage), the HBATH (MON1), and LOS (MON3) signals against the internal APC, BIAS, and MON3 reference, respectively. If the last APC comparison was higher than the APC set point, it makes an HTXP comparison, and if it is lower, it makes an LTXP comparison. Depending on the results of the comparison, the corresponding alarms and warnings (TXP HI, TXP LO) are asserted or deasserted.

The device has a programmable comparator sample time based on an internally generated clock to facilitate a wide variety of external filtering options and time delays resulting from writing values to the laser driver's bias DAC. The SAMPLE RATE register (Table 02h, Register 88h) determines the sampling time. Samples occur at a regular interval, t_{REP} . Table 2 shows the sample rate options available. Any quick-trip alarm that is detected by default remains active until a subsequent comparator sample shows the condition no longer exists. A second bias current monitor (BIAS MAX) compares a Maxim laser driver's BIAS DAC's code to a digital value stored in the IBIASMAX register. This comparison is made at every bias current update to ensure that a high-bias current is quickly detected.

Table 2. Update Rate Timing

APC_SR[2:0]	SAMPLE PERIOD (t_{REP}) (ns)
000b	800
001b	1200
010b	1600
011b	2000
100b	2800
101b	3200
110b	4400
111b	6400

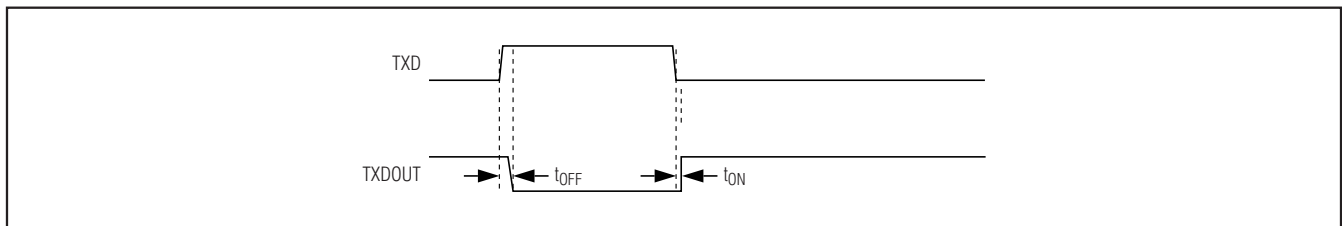

Figure 3. TXD Timing

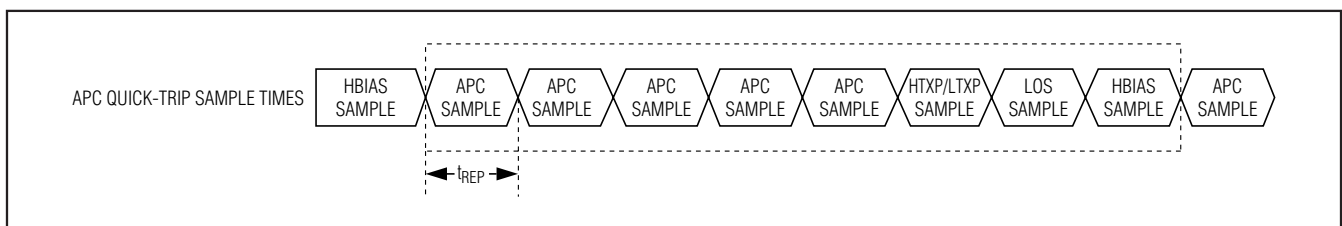

Figure 4. APC Loop and Quick-Trip Sample Timing

SFP+ Controller with Digital LDD Interface

An APC sample that requires an update of the BIAS register causes subsequent APC samples to be ignored until the end of the 3-wire communication that updates the laser driver's BIAS DAC, plus an additional 16 sample periods (t_{REP}).

Monitors and Fault Detection

Monitors

Monitoring functions on the device include five quick-trip comparators and six ADC channels. This monitoring combined with the alarm enables (Table 01h/05h) determines when/if the device turns off the Maxim laser driver's DACs and triggers the TXFOUT and TXDOUT outputs. All the monitoring levels and interrupt masks are user programmable.

Five Quick-Trip Monitors and Alarms

Five quick trip monitors are provided to detect potential laser safety issues and LOS status. These monitor the following:

- 1) High Bias Current (HBATH), causing QT BIAS HI
- 2) Low Transmit Power (LTXP), causing QT TXP LO
- 3) High Transmit Power (HTXP), causing QT TXP HI
- 4) Max Output Current (IBIASMAX), causing QT BIAS MAX
- 5) Loss of Signal (LLOS), causing QT LOS LO

The high and low transmit power quick-trip registers (HTXP and LTXP) set the thresholds used to compare against the MON2 voltage to determine if the transmit power is within specification. The HBATH quick trip compares the MON1 input (generally from a Maxim laser driver bias monitor output) against its threshold setting to determine if the present bias current is above specification. The user can program up to eight different temperature-indexed threshold levels for HBATH (Table 02h, Registers D0h–D7h).

The BIAS MAX quick trip compares the BIAS register with the MON2 voltage and determines if the BIAS register is above specification. The BIAS register is not allowed to exceed the value set in the IBIASMAX register. When the device detects the bias is at the limit, it sets the BIAS MAX status bit and holds the BIAS register setting at the IBIASMAX level.

The LOS LO quick trip compares the MON3 input against its threshold setting (LLOS) to determine if the present received power is below the specification. The LOS RANGING register allows the LOS threshold value to scale. The LOS LO quick trip can be used to set the LOSOUT pin. LOS HI does not set LOSOUT. See the description of the LOS LO and LOS HI bits (Table 01h, Register FBh) for further details of operation.

The quick trips are routed to create TXFOUT through interrupt masks to allow combinations of these alarms to be used to trigger the outputs.

Six ADC Monitors and Alarms

The ADC monitors six channels that measure temperature (internal temp sensor), V_{CC} , and MON1–MON4 using an analog multiplexer to measure them round robin with a single ADC (see the *ADC Timing* section). The five voltage channels have a customer-programmable full-scale range and all channels have a customer-programmable offset value that is factory programmed to default value (see Table 3). Additionally, MON1–MON4 can right-shift results by up to 7 bits before the results are compared to alarm thresholds or read over the I²C bus. This allows customers with specified ADC ranges to calibrate the ADC full scale to a factor of $1/2^n$ of their specified range to measure small signals. The device can then right-shift the results by n bits to maintain the bit weight of their specification (see the *Right-Shifting ADC Result* and *Enhanced RSSI Monitoring (Dual-Range Functionality)* sections).

The ADC results (after right-shifting, if used) are compared to the alarm and warning thresholds after each conversion, and the corresponding alarms are set, which can be used to trigger the TXFOUT output. These ADC thresholds are user programmable, as are the masking registers that can be used to prevent the alarms from triggering the TXFOUT output.

ADC Timing

There are six analog channels that are digitized in a round-robin fashion in the order shown in Figure 5. The total time required to convert all six channels is t_{RR} (see the *Analog Voltage Monitoring Characteristics* for details).

Table 3. ADC Default Monitor Full-Scale Ranges

SIGNAL (UNITS)	+FS SIGNAL	+FS HEX	-FS SIGNAL	-FS HEX
Temperature (°C)	127.996	7FFF	-128	8000
V_{CC} (V)	6.5528	FFF8	0	0000
MON1–MON4 (V)	2.4997	FFF8	0	0000

SFP+ Controller with Digital LDD Interface

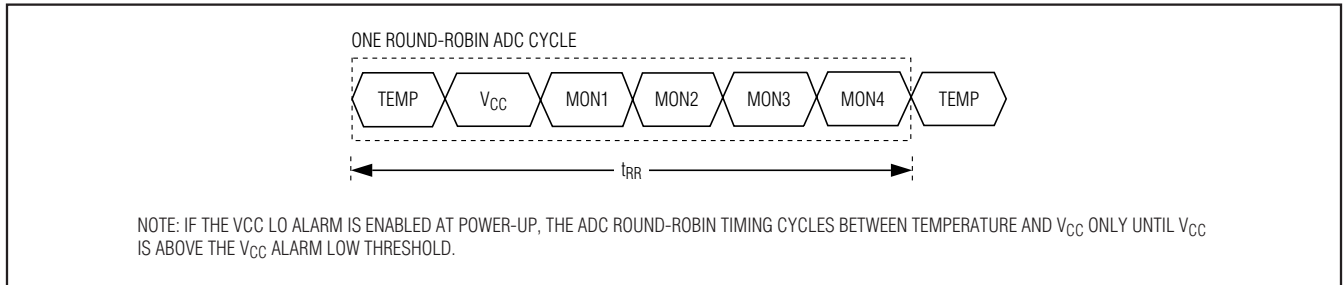

Figure 5. ADC Round-Robin Timing

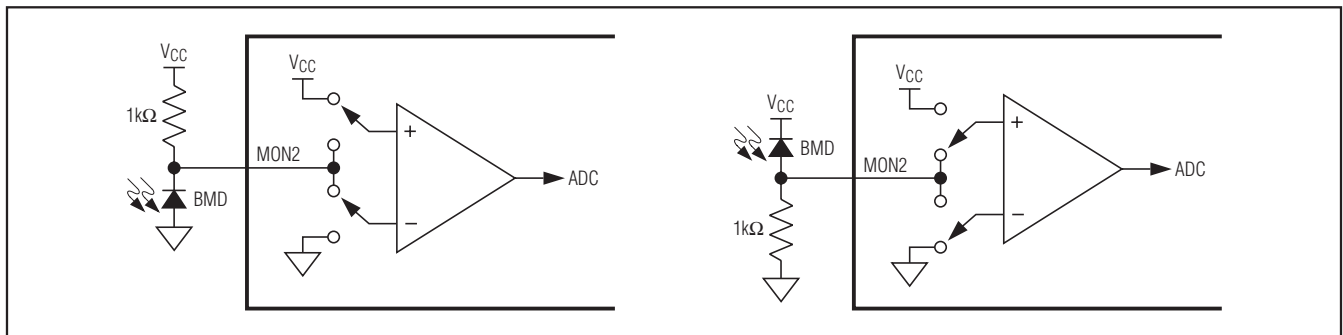

Figure 6. MON2 V_{CC} or GND Reference

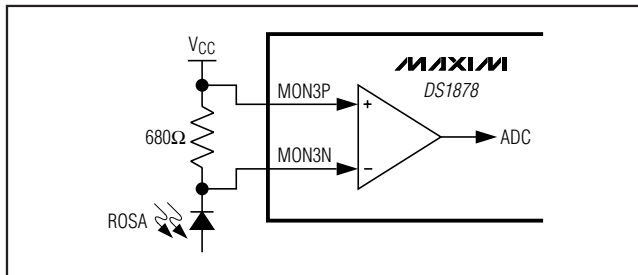

Figure 7. MON3 Differential Input for High-Side RSSI

Right-Shifting ADC Result

If the weighting of the ADC digital reading must conform to a predetermined full-scale (PFS) value defined by a standard's specification (e.g., SFF-8472), then right-shifting can be used to adjust the PFS analog measurement range while maintaining the weighting of the ADC results. The device's range is wide enough to cover all requirements; when the maximum input value is $\leq 1/2$ of the FS value, right-shifting can be used to obtain greater accuracy. For instance, the maximum voltage might be $1/8$ the specified PFS value, so only $1/8$ the converter's range is effective over this range. An alternative is to calibrate the ADC's full-scale range to $1/8$ the readable PFS value and use a right-shift value of 3. With this implementation, the resolution of the measurement is increased by a factor of 8, and

because the result is digitally divided by 8 by right-shifting, the bit weight of the measurement still meets the standard's specification (i.e., SFF-8472).

The right-shift operation on the ADC result is carried out based on the contents of right-shift control registers (Table 02h, Registers 8Eh–8Fh) in EEPROM. Three analog channels, MON1–MON3, each have 3 bits allocated to set the number of right-shifts. Up to seven right-shift operations are allowed and are executed as a part of every conversion before the results are compared to the high-alarm and low-alarm levels, or loaded into their corresponding measurement registers (Lower Memory, Registers 64h–6Bh). This is true during the setup of internal calibration as well as during subsequent data conversions.

V_{CC} or GND Referenced MON2 Input

The device offers a configurable input for MON2. MON2 can either be referenced to V_{CC} or GND, as shown in Figure 6. This enables compatibility with different TOSA monitor diode configurations.

Differential MON3 Input

The device offers a fully differential input for MON3. This enables high-side monitoring of RSSI, as shown in Figure 7. This reduces board complexity by eliminating the need for a high-side differential amplifier or a current mirror.

SFP+ Controller with Digital LDD Interface

Enhanced RSSI Monitoring (Dual-Range Functionality)

The device offers a feature to improve the accuracy and range of MON3, which is most commonly used for monitoring RSSI. Using a traditional input, the accuracy of the RSSI measurements is increased at the cost of

reduced input signal swing. The device eliminates this trade-off by offering “dual range” calibration on the MON3 channel.

The dual-range calibration can operate in two modes: crossover enabled and crossover disabled.

Table 4. MON3 Hysteresis Threshold Values

NUMBER OF RIGHT-SHIFTS	FINE MODE MAX (HEX)	COARSE MODE MIN* (HEX)
0	FFF8	F000
1	7FFC	7800
2	3FFE	3C00
3	1FFF	1E00
4	0FFF	0F00
5	07FF	0780
6	03FF	03C0
7	01FF	01E0

*This is the minimum reported coarse-mode conversion.

Table 5. MON3 Configuration Registers

REGISTER	FINE MODE	COARSE MODE
GAIN	98h–99h, Table 02h	9Ch–9Dh, Table 02h
OFFSET	A8h–A9h, Table 02h	ACH–ADh, Table 02h
RIGHT-SHIFT ₀	8Fh, Table 02h	8Fh, Table 02h
CNFGC (RSSI_FC and RSSI_FF Bits)	8Bh, Table 02h	
UPDATE (RSSIR Bit)	6Fh, Lower Memory	
MON3 VALUE	68h–69h, Lower Memory	

- Crossover Enabled:** For systems with a nonlinear relationship between the ADC input and desired ADC result, the mode should be set to crossover enabled (Figure 8). The RSSI measurement of an APD receiver is one such application. Using the crossover enabled mode allows a piecewise linear approximation of the nonlinear response of the APD’s gain factor. The crossover point is the point between fine and coarse points. The ADC result transitions between the fine and coarse ranges with no hysteresis. Right-shifting, slope adjustment, and offset are configurable for both the fine and coarse ranges. The XOVER FINE register determines the maximum results returned by fine ADC conversions, before right-shifting. The XOVER COARSE register determines the minimum results returned by coarse ADC conversions, before right-shifting.

- Crossover Disabled:** The crossover disabled mode is intended for systems with a linear relationship between the MON3 input and desired ADC result. The ADC result transitions between the fine and coarse ranges with hysteresis (Figure 9). In crossover disabled mode, the thresholds between coarse and fine mode are a function of the number of right-shifts being used. With the use of right-shifting, the fine-mode full scale is programmed to $(1/2^{nth})$ of the coarse-mode full scale. The device now auto ranges to choose the range that gives the best resolution for the measurement. Table 4 shows the threshold values for each possible number of right-shifts.

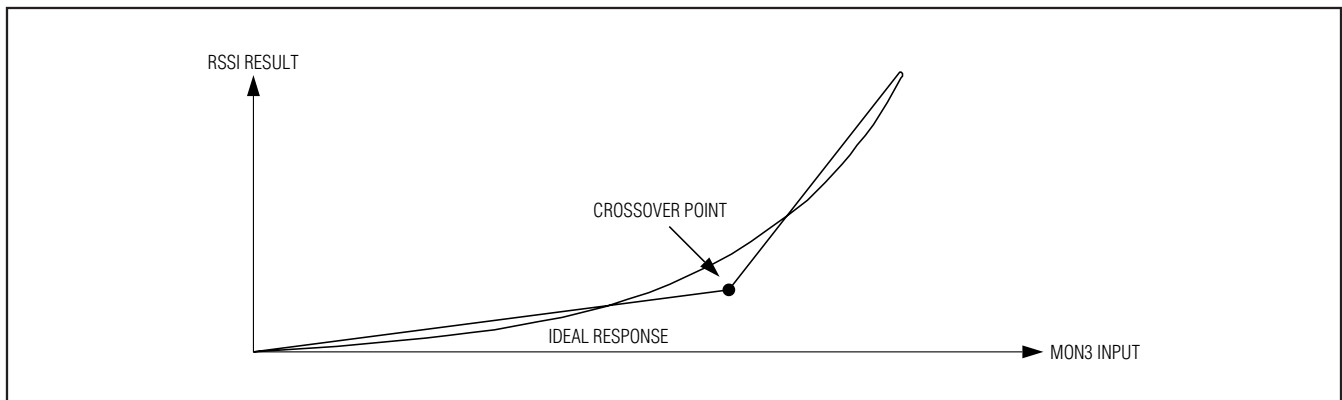

Figure 8. RSSI with Crossover Enabled

SFP+ Controller with Digital LDD Interface

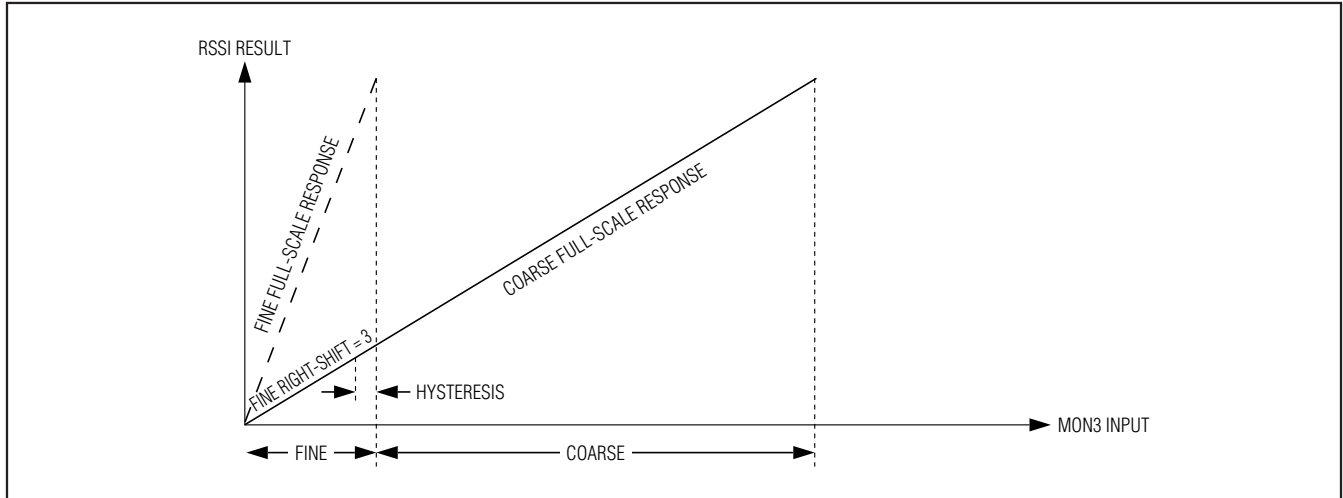

Figure 9. RSSI with Crossover Disabled

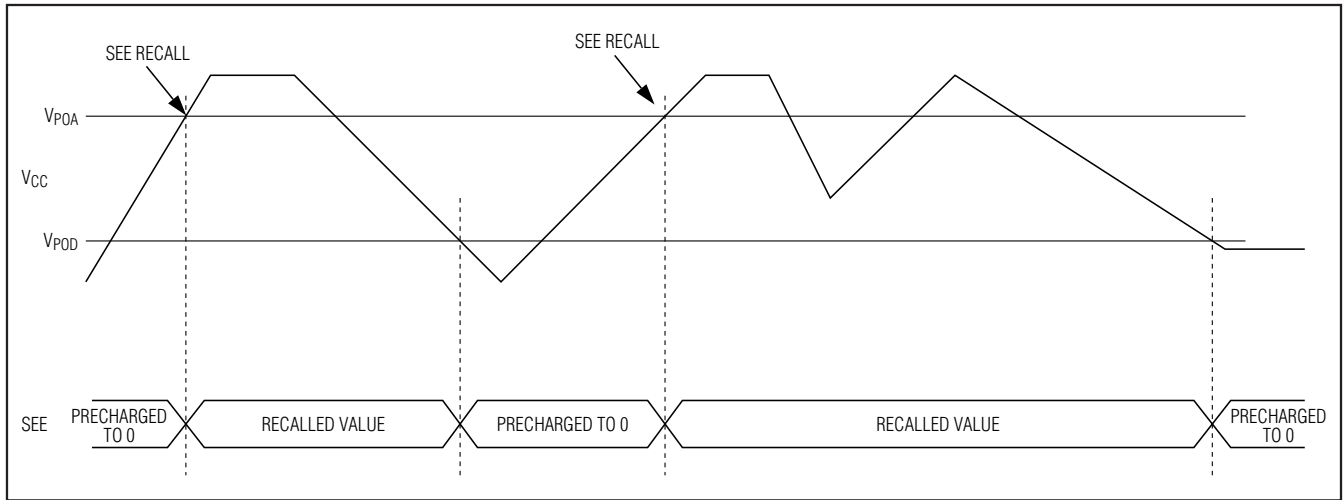

Figure 10. Low-Voltage Hysteresis Example

Low-Voltage Operation

The device contains two power-on reset (POR) levels. The lower level is a digital POR (POD) and the higher level is an analog POR (POA). At startup, before the supply voltage rises above POA, the outputs are disabled, all SRAM locations are set to their defaults, shadowed EEPROM (SEE) locations are zero, and all analog circuitry is disabled. When V_{CC} reaches POA, the SEE is recalled, and the analog circuitry is enabled. While V_{CC} remains above POA, the device is in its normal operating state, and it responds based on its non-volatile configuration. If during operation V_{CC} falls below POA, but is still above POD, then the SRAM retains the SEE settings from the first SEE recall, but the

device analog is shut down and the outputs disabled. If the supply voltage recovers back above POA, then the device immediately resumes normal operation. If the supply voltage falls below POD, then the device SRAM is placed in its default state and another SEE recall is required to reload the nonvolatile settings. The EEPROM recall occurs the next time V_{CC} exceeds POA. Figure 10 shows the sequence of events as the voltage varies.

Any time V_{CC} is above POD, the I²C interface can be used to determine if V_{CC} is below the POA level. This is accomplished by checking the RDYB bit in the STATUS (Lower Memory, Register 6Eh) byte. RDYB is set when V_{CC} is below POA; when V_{CC} rises above POA, RDYB

SFP+ Controller with Digital LDD Interface

is timed (within 500µs) to go to 0, at which point the part is fully functional.

For all device addresses sourced from EEPROM (Table 02h, Register 8Ch), the default device address is A2h until VCC exceeds POA, allowing the device address to be recalled from the EEPROM.

Power-On Analog (POA)

POA holds the device in reset until VCC is at a suitable level (VCC > POA) for the device to accurately measure with its ADC and compare analog signals with its quick-

trip monitors. Because VCC cannot be measured by the ADC when VCC is less than POA, POA also asserts the VCC LO alarm, which is cleared by a VCC ADC conversion greater than the customer-programmable VCC LO ADC limit. This allows a programmable limit to ensure that the headroom requirements of the transceiver are satisfied during a slow power-up. The TXFOUT output does not latch until there is a conversion above the VCC LO limit. The POA alarm is nonmaskable. The TXF output is asserted when VCC is below POA. See the *Low-Voltage Operation* section for more information.

Delta-Sigma Outputs (DAC1 and DAC2)

Two delta-sigma outputs are provided, DAC1 and DAC2. With the addition of an external RC filter, these outputs provide two 9-bit resolution analog outputs with the full-scale range set by the input REFIN. Each output is either manually controlled or controlled using a temperature-indexed LUT. A delta-sigma is a digital output using pulse-density modulation. It provides much lower output ripple than a standard digital PWM output given the same clock rate and filter components. Before t_{INIT}, the DAC1 and DAC2 outputs are high impedance.

The external RC filter components are chosen based on ripple requirements, output load, delta-sigma frequency, and desired response time. A recommended filter is shown in Figure 11.

The device's delta-sigma outputs are 9 bits. For illustrative purposes, a 3-bit example is provided in Figure 12.

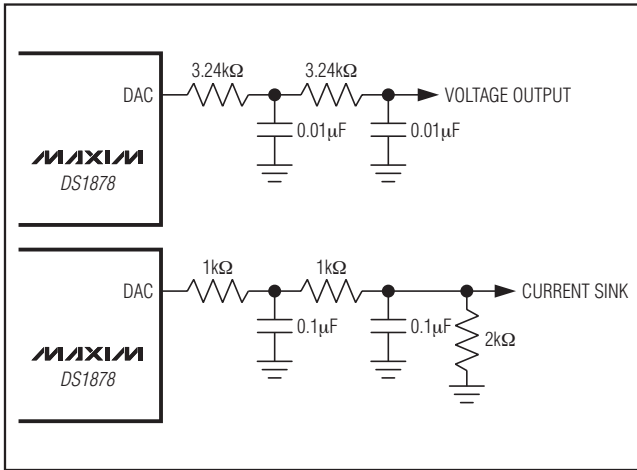

Figure 11. Recommended RC Filter for DAC1/DAC2

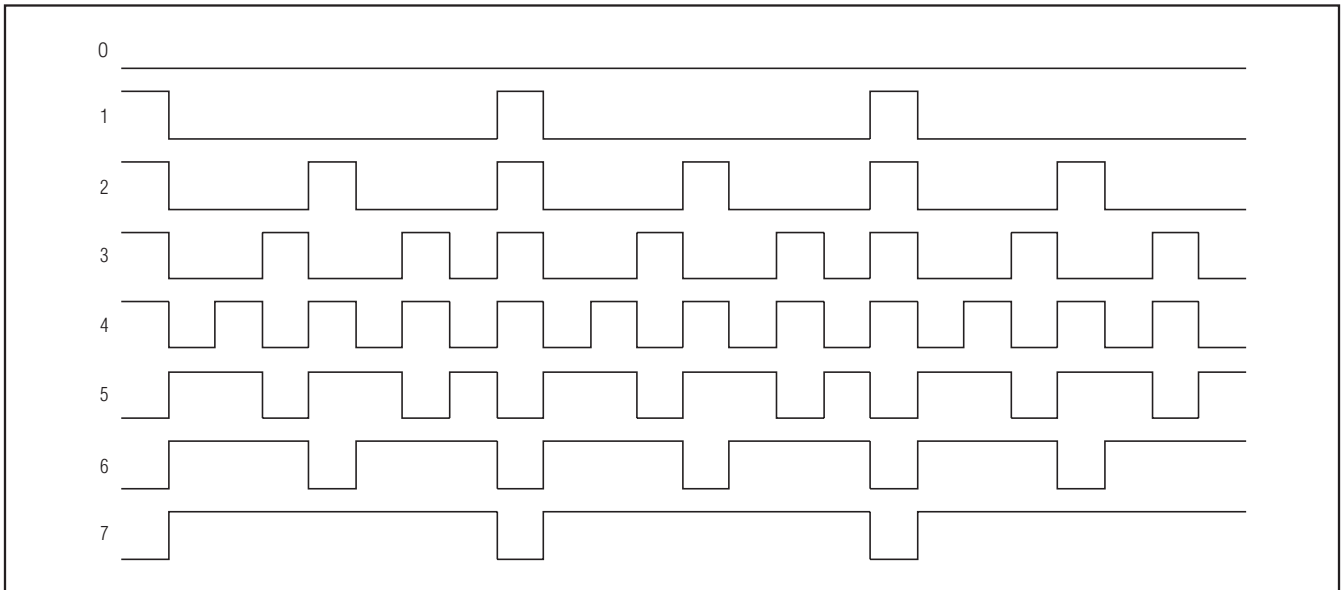

Figure 12. Delta-Sigma Outputs

SFP+ Controller with Digital LDD Interface

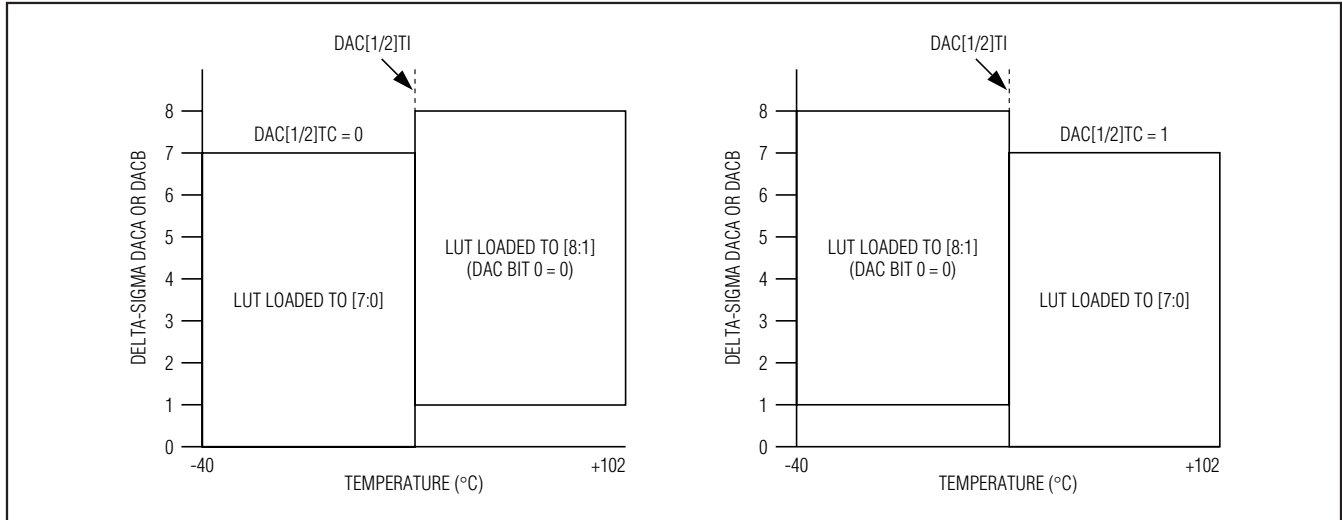

Figure 13. DAC1/DAC2 LUT Assignments

In LUT mode, DAC1 and DAC2 are each controlled by a separate 8-bit, 4°C-resolution, temperature-addressed LUT. The delta-sigma outputs use a 10-bit structure. The 8-bit LUTs are either loaded directly into the MSBs (8:1) or the LSBs (7:0). This is determined by DAC1TI (Table 02h, Register C3h), DAC2TI (Table 02h, Register C4h), DAC1TC (Table 02h, Register C6h, bit 6), and DAC2TC (Table 02h, Register C6h, bit 5). See Figure 13 for more details. The DAC1 LUT (Table 07h) and DAC2 LUT (Table 08h) registers are nonvolatile and password-2 protected.

The reference input, REFIN, is the supply voltage for the output buffer of DAC1 and DAC2. The voltage connected to REFIN must be able to support the edge rate requirements of the delta-sigma outputs. In a typical application, a 0.1µF capacitor should be connected between REFIN and ground.

Digital I/O Pins

Five digital input and four digital output pins are provided for monitoring and control.

LOS, LOSOUT

By default (LOSC = 1, Table 02h, Register 89h), the LOS pin is used to convert a standard comparator output for loss of signal (LOS) to an open-collector output. This means the mux shown in the *Block Diagram* by default selects the LOS pin as the source for the LOSOUT output transistor. The output of the mux can be read in the STATUS byte (Lower Memory, Register 6Eh) as the RXL bit. The RXL signal can be inverted (INV LOS = 1) before driving the open-drain output transistor using the XOR gate provided. Setting

LOSC = 0 configures the mux to be controlled by LOS LO, which is driven by the output of the LOS quick trip (Table 02h, Registers BEh and BFh). The mux setting (stored in EEPROM) does not take effect until $V_{CC} > POA$, allowing the EEPROM to recall.

IN1, RSEL, RSELOUT

The digital input IN1 and RSEL pins primarily serve to meet the rate-select requirements of SFP and SFP+. They also serve as general-purpose inputs. RSELOUT is driven by a combination of the RSEL and logic dictated by control registers in the EEPROM (Figure 15). The levels of IN1 and RSEL can be read using the STATUS register (Lower Memory, Register 6Eh). The open-drain RSELOUT output is software-controlled and/or inverted through the STATUS register and CNFGA register (Table 02h, Register 89h). External pullup resistors must be provided on RSELOUT to realize a high logic level. The RSEL pin determines the value sent by the 3-wire master to the limiting amplifier's SETLOS register. When RSEL is high, SETLOSH is used. When RSEL is low, SETLOSL is used.

TXD, TXDOUT

TXDOUT is generated from a combination of TXFOUT, TXD, and the internal signal FETG. A software control identical to TXD is available (TXDC, Lower Memory, Register 6Eh). A TXD pulse is internally extended (t_{INTR1}) to inhibit the latching of low alarms and warnings related to the APC loop to allow for the loop to stabilize. The nonlatching alarms and warnings are TXP LO, LOS LO, and MON1-MON4 LO alarms and warnings. In addition, TXP LO is disabled from creating

SFP+ Controller with Digital LDD Interface

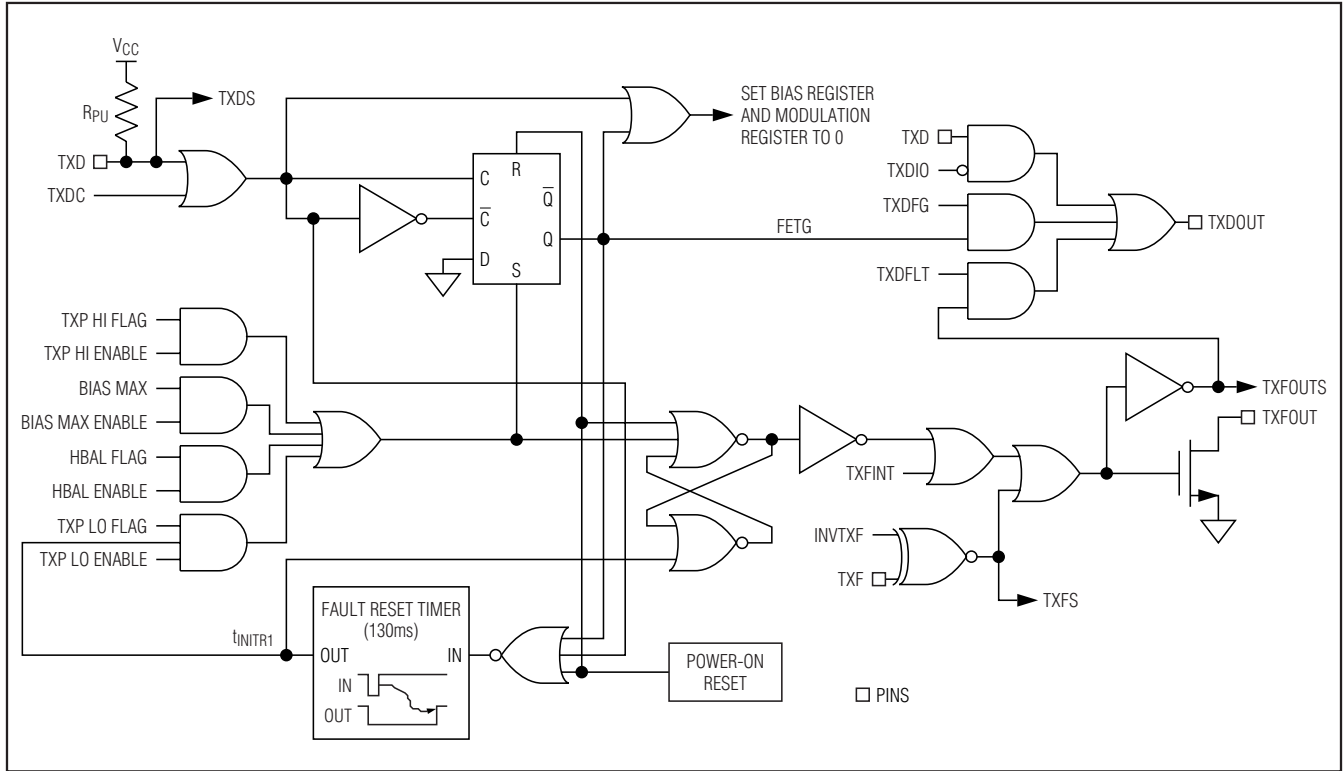

Figure 14. Logic Diagram 1

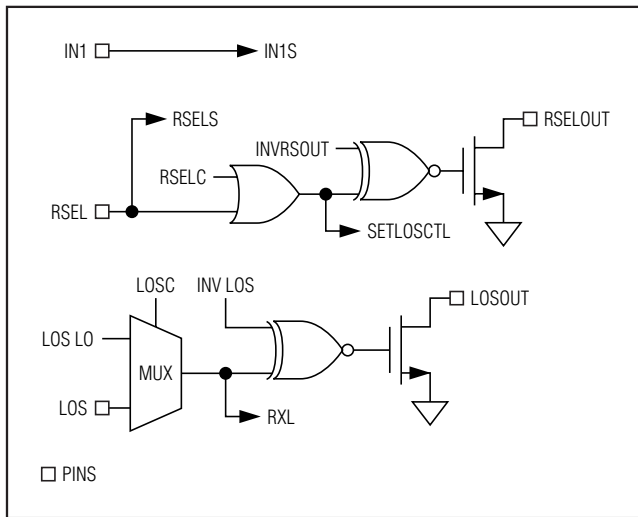

Figure 15. Logic Diagram 2

FETG. See the *Transmit Fault (TXFOUT) Output* section for a detailed explanation of TXFOUT. Figure 14 shows that the same signals and faults can also be used to generate the internal signal FETG (Table 01h/05h, Registers FAh–FBh). FETG is used to send a fast “turn-off” command to the laser driver. The status of FTEG can be read (Lower Memory, Register 71h). The intended use is a direct connection to the Maxim laser driver’s TXD input if this is desired. When $V_{CC} < POA$, TXDOUT is high impedance.

Transmit Fault (TXFOUT) Output

TXFOUT can be triggered by TXF input and all alarms, warnings, and quick trips (Figure 15). The six ADC alarms, warnings, and the LOS quick trips require enabling (Table 01h/05h, Registers F8h, FCh–FDh). See Figures 16a and 16b for nonlatched and latched operation. Latching of the alarms is controlled by the CNFGB and CNFGC registers (Table 02h, Registers 8Ah–8Bh).

SFP+ Controller with Digital LDD Interface

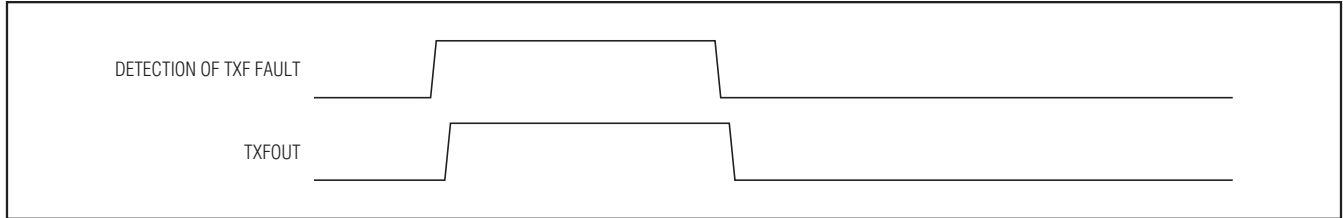

Figure 16a. TXFOUT Nonlatched Operation

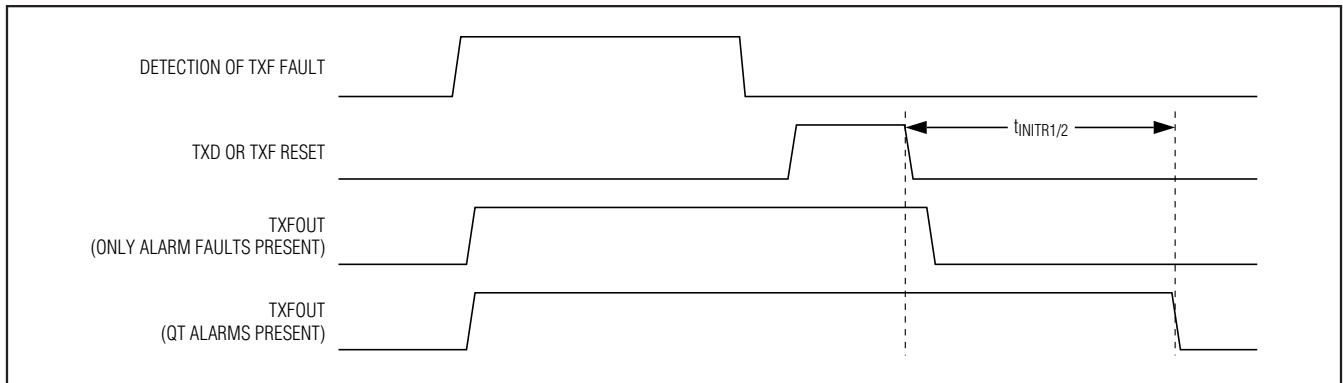

Figure 16b. TXFOUT Latched Operation

Die Identification

The DS1878 has an ID hardcoded in its die. Two registers (Table 02h, Registers CEh–CFh) are assigned for this feature. The CEh register reads 78h to identify the part as the DS1878, while the CFh register reads the current device version.

3-Wire Master for Controlling the Maxim Laser Driver and Limiting Amplifier

The device controls a Maxim laser driver and limiting amplifier over a proprietary 3-wire interface. The device acts as the master, initiating communication with and generating the clock for the Maxim slave device(s). It is a 3-pin interface consisting of SDAOUT (a bidirectional data line), SCLOUT (clock signal), and a chip-select output (active high). Two chip selects are provided. CSEL1OUT is active during all communications. CSEL2OUT is only active during communications to the limiting amplifier. By connecting CSEL2OUT to a Maxim limiting amplifier, there is less noise induced by the communication interface on the limiting amplifier, since none of the laser driver communications are processed by the limiting amplifier.

Protocol

The device initiates a data transfer by asserting the CSEL_OUT pin. It then starts to generate a clock signal after CSEL_OUT has been set to 1. Each operation consists of 16-bit transfers (15-bit address/data, 1-bit RWN). All data transfers are MSB first.

BIT	NAME	DESCRIPTION
15:9	Address	7-bit internal register address
8	RWN	0: write; 1: read
7:0	Data	8-bit read or write data

Write Mode (RWN = 0): The master generates 16 clock cycles at SCLOUT in total. It outputs 16 bits (MSB first) to the SDAOUT line at the falling edge of the clock. The master closes the transmission by setting CSEL_OUT to 0.

Read Mode (RWN = 1): The master generates 16 clock cycles at SCLOUT in total. It outputs 8 bits (MSB first) to the SDAOUT line at the falling edge of the clock. The SDAOUT line is released after the RWN bit has been transmitted. The slave outputs 8 bits of data (MSB first) at the rising edge of the clock. The master samples SDAOUT at the falling edge of SCLOUT. The master closes the transmission by setting CSEL_OUT to 0.

SFP+ Controller with Digital LDD Interface

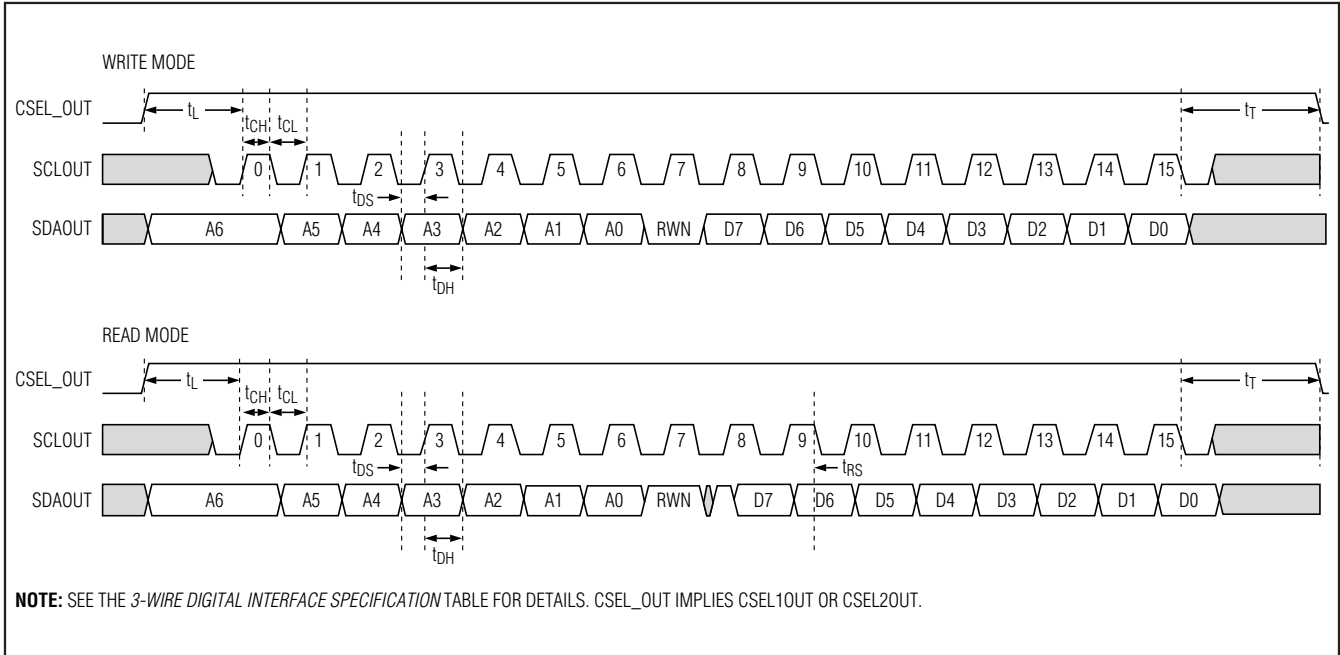

Figure 17. 3-Wire Timing

3-Wire Interface Timing

Figure 17 shows the 3-wire interface timing. Figure 18 shows the 3-wire state machine. See the *3-Wire Digital Interface Specification* table for more information.

DS1878 Master Communication Interface

Normal Operation

The majority of the communications consist of bias adjustments for the APC loop. After each temperature conversion, the laser modulation setting must be updated. All registers are rewritten after every temperature conversion. Status registers TXSTAT1 and TXSTAT2 are read between temperature updates at a regular interval, t_{RR} (see the *Analog Voltage Monitoring Characteristics* table). The results are stored in 3W TXSTAT1 and 3W TXSTAT2 (Table 02h, FCh–FDh). Two chip selects are provided: CSEL1OUT and CSEL2OUT. In the case where a separate limiting amplifier and laser driver are used, CSEL2OUT should be connected to the limiting amplifier. CSEL2OUT is only active when receiver-related registers are accessed. This minimizes noise caused by the digital interface.

Manual Operation

The master interface is controllable using four registers in the device: 3WCTRL, ADDRESS, WRITE, and READ.

Commands can be manually issued while the device is in normal operation mode. It is also possible to suspend normal 3-wire commands so that only manual operation commands are sent (3WCTRL, Table 02h, Register F8h).

Initialization

During initialization, the device transfers all its 3-wire EEPROM control registers to a Maxim laser driver and limiting amplifier. The 3-wire control registers include the following:

- RXCTRL1
- RXCTRL2
- SETCML
- SETLOS
- TXCTRL
- IMODMAX
- IBIASMAX
- SETPWCTL
- SETTIDE
- SETTSEQ
- SETLOSTIMER
- RXCTRL3
- TXCTRL2
- TXCTRL3

SFP+ Controller with Digital LDD Interface

The control registers are first written once VCC exceeds POA. They are also written after every temperature conversion and on a rising edge of TXD. Any time one of

these events occurs, the device reads and updates TXSTAT1 and TXSTAT2, and writes SET_IBIAS and SET_IMOD to 0.

DS1878

Slave Register Map and DS1878 Corresponding Location

SLAVE REGISTER AND ADDRESS	DS1878 REGISTER	ACTIVE CHIP SELECTS	REGISTER FUNCTION	DS1878 LOCATION
00h, RXCTRL1	RXCTRL1	1 and 2	Receiver Control	Table 02h, E8h
01h, RXCTRL2	RXCTRL2	1 and 2	Receiver Control	Table 02h, E9h
02h, RXSTAT	STATUS	1 and 2	Receiver Status	Lower Memory, 6Eh, Bit 1 comes from the LOSOUT pin (Note 1)
03h, SET_CML	SETCML	1 and 2	Output CML Level Setting	Table 02h, EAh
04h, SET_LOS	SETLOSH, SETLOSL	1 and 2	LOS Assert Level Settings	Table 02h, EBh is SETLOSH, Table 02h, F3h is SETLOSL (Note 2)
05h, TXCTRL	TXCTRL	1 Only (Note 3)	Transmitter Control	Table 02h, ECh
06h, TXSTAT1	TXSTAT1	1 Only (Note 3)	Transmitter Status	Table 02h, FCh
07h, TXSTAT2	TXSTAT2	1 Only (Note 3)	Transmitter Status	Table 02h, FDh
08h, SET_IBIAS	BIAS	1 Only (Note 3)	BIAS Current Setting	Table 02h, CBh–CCh
09h, SET_IMOD	MODULATION	1 Only (Note 3)	MODULATION Current Setting	Table 02h, 82h–83h
0Ah, SET_IMODMAX	IMODMAX	1 Only (Note 3)	MODULATION Current Limit Setting	Table 02h, EDh
0Bh, SET_IBIASMAX	IBIASMAX	1 Only (Note 3)	BIAS Current Limit Setting	Table 02h, EEh
0Ch, MODINC	MODINC	1 Only (Note 3)	MODULATION Current DAC Increment Setting	Automatically written after each temperature conversion.
0Dh, BIASINC	BIASINC	1 Only (Note 3)	BIAS Current DAC Increment Setting	Automatically performed by APC loop. Disable APC before using 3-wire manual mode.
0Eh, MODECTRL	MODECTRL	1 and 2	General Control	(Note 1)
0Fh, SET_PWCTRL	SETPWCTRL	1 Only (Note 3)	Tx Pulse Width Setting	Table 02h, EFh
10h, SET_TXDE	SETTXDE	1 Only (Note 3)	Tx Deemphasis Setting	Table 02h, F0h
11h, SET_TXEQ	SETTXEQ	1 Only (Note 3)	Tx Equalization	Table 02h, F1h
12h, SET_LOSTIMER	SETLOSTIMER	1 and 2	LOS Timer	Table 02h, F2h
14h, TXTM	TXTM	1 and 2	Tx Test Mode	(Note 1)
15h, RXTM1	RXTM1	1 and 2	Rx Test Mode	(Note 1)
16h, RXTM2	RXTM2	1 and 2	Rx Test Mode	(Note 1)
17h, Reserved	RXCTRL3	1 and 2	Receiver Control	Table 02h, F4h
18h, Reserved	TXCTRL2	1 Only (Note 3)	Transmitter Control	Table 02h, F5h
19h, Reserved	TXCTRL3	1 Only (Note 3)	Transmitter Control	Table 02h, F6h

Note 1: This register is not present in the DS1878. To access this register the user must use manual operation (see the Manual Operation section for details).

Note 2: Either SETLOSH or SETLOSL is written to the slave register SET_LOS. This is determined by the signal RSEL (see Figure 15).

Note 3: In manual 3-wire mode both chip selects are active for all registers.

SFP+ Controller with Digital LDD Interface

I²C Communication

I²C Definitions

The following terminology is commonly used to describe I²C data transfers.

Master device: The master device controls the slave devices on the bus. The master device generates SCL clock pulses and START and STOP conditions.

Slave devices: Slave devices send and receive data at the master's request.

Bus idle or not busy: Time between STOP and START conditions when both SDA and SCL are inactive and in their logic-high states.

START condition: A START condition is generated by the master to initiate a new data transfer with a slave. Transitioning SDA from high to low while SCL remains high generates a START condition. See Figure 19 for applicable timing.

STOP condition: A STOP condition is generated by the master to end a data transfer with a slave. Transitioning SDA from low to high while SCL remains high generates a STOP condition. See Figure 19 for applicable timing.

Repeated START condition: The master can use a repeated START condition at the end of one data transfer to indicate that it will immediately initiate a new data transfer following the current one. Repeated STARTs are commonly used during read

operations to identify a specific memory address to begin a data transfer. A repeated START condition is issued identically to a normal START condition. See Figure 19 for applicable timing.

Bit write: Transitions of SDA must occur during the low state of SCL. The data on SDA must remain valid and unchanged during the entire high pulse of SCL plus the setup and hold time requirements (Figure 19). Data is shifted into the device during the rising edge of the SCL.

Bit read: At the end a write operation, the master must release the SDA bus line for the proper amount of setup time (Figure 19) before the next rising edge of SCL during a bit read. The device shifts out each bit of data on SDA at the falling edge of the previous SCL pulse and the data bit is valid at the rising edge of the current SCL pulse. Remember that the master generates all SCL clock pulses, including when it is reading bits from the slave.

Acknowledgement (ACK and NACK): An acknowledgement (ACK) or not acknowledge (NACK) is always the ninth bit transmitted during a byte transfer. The device receiving data (the master during a read or the slave during a write operation) performs an ACK by transmitting a zero during the ninth bit. A device performs a NACK by transmitting a one during the 9th bit. Timing (Figure 19) for the ACK and NACK is identical to all other bit writes. An ACK is the acknowledgment that the device is properly receiving data. A NACK is used to terminate a read

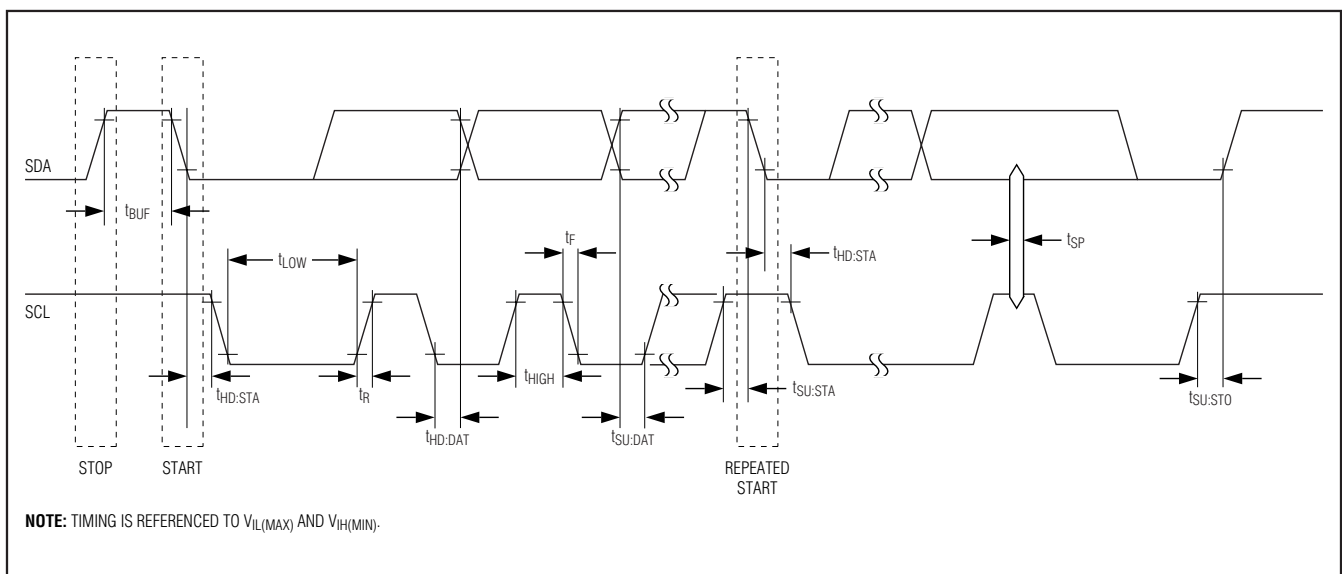

Figure 19. I²C Timing

SFP+ Controller with Digital LDD Interface

sequence or as an indication that the device is not receiving data.

Byte write: A byte write consists of 8 bits of information transferred from the master to the slave (most significant bit first) plus a 1-bit acknowledgement from the slave to the master. The 8 bits transmitted by the master are done according to the bit-write definition and the acknowledgement is read using the bit-read definition.

Byte read: A byte read is an 8-bit information transfer from the slave to the master plus a 1-bit ACK or NACK from the master to the slave. The 8 bits of information that are transferred (most significant bit first) from the slave to the master are read by the master using the bit-read definition, and the master transmits an ACK using the bit-write definition to receive additional data bytes. The master must NACK the last byte read to terminate communication so the slave returns control of SDA to the master.

Slave address byte: Each slave on the I²C bus responds to a slave address byte sent immediately following a START condition. The slave address byte contains the slave address in the most significant 7 bits and the R/W bit in the least significant bit.

The device responds to two slave addresses. The auxiliary memory always responds to a fixed I²C slave address, A0h. The Lower Memory and Tables 00h–08h respond to I²C slave addresses that can be configured to any value between 00h–FEh using the DEVICE ADDRESS byte (Table 02h, Register 8Ch). The user also must set the ASEL bit (Table 02h, Register 89h) for this address to be active. By writing the correct slave address with R/W = 0, the master indicates it will write data to the slave. If R/W = 1, the master reads data from the slave. If an incorrect slave address is written, the device assumes the master is communicating with another I²C device and ignores the communications until the next START condition is sent. If the main device's slave address is programmed to be A0h, access to the auxiliary memory is disabled.

Memory address: During an I²C write operation to the device, the master must transmit a memory address to identify the memory location where the slave is to store the data. The memory address is always the second byte transmitted during a write operation following the slave address byte.

I²C Protocol

Writing a single byte to a slave: The master must generate a START condition, write the slave address byte (R/W = 0), write the memory address, write the

byte of data, and generate a STOP condition. Remember the master must read the slave's acknowledgement during all byte-write operations.

Writing multiple bytes to a slave: To write multiple bytes to a slave, the master generates a START condition, writes the slave address byte (R/W = 0), writes the memory address, writes up to 8 data bytes, and generates a STOP condition. The device writes 1 to 8 bytes (one page or row) with a single write transaction. This is internally controlled by an address counter that allows data to be written to consecutive addresses without transmitting a memory address before each data byte is sent. The address counter limits the write to one 8-byte page (one row of the memory map). Attempts to write to additional pages of memory without sending a STOP condition between pages results in the address counter wrapping around to the beginning of the present row.

For example, a 3-byte write starts at address 06h and writes 3 data bytes (11h, 22h, and 33h) to three "consecutive" addresses. The result is that addresses 06h and 07h would contain 11h and 22h, respectively, and the third data byte, 33h, would be written to address 00h.

To prevent address wrapping from occurring, the master must send a STOP condition at the end of the page, then wait for the bus-free or EEPROM write time to elapse. Then the master can generate a new START condition and write the slave address byte (R/W = 0) and the first memory address of the next memory row before continuing to write data.

Acknowledge polling: Any time a EEPROM page is written, the device requires the EEPROM write time (t_{WR}) after the STOP condition to write the contents of the page to EEPROM. During the EEPROM write time, the device does not acknowledge its slave address because it is busy. It is possible to take advantage of that phenomenon by repeatedly addressing the device, which allows the next page to be written as soon as the device is ready to receive the data. The alternative to acknowledge polling is to wait for maximum period of t_{WR} to elapse before attempting to write again to the device.

EEPROM write cycles: When EEPROM writes occur, the device writes the whole EEPROM memory page, even if only a single byte on the page was modified. Writes that do not modify all 8 bytes on the page are allowed and do not corrupt the remaining bytes of memory on the same page. Because the whole page is written, bytes on the page that were not modified during the transaction are still subject to a write

SFP+ Controller with Digital LDD Interface

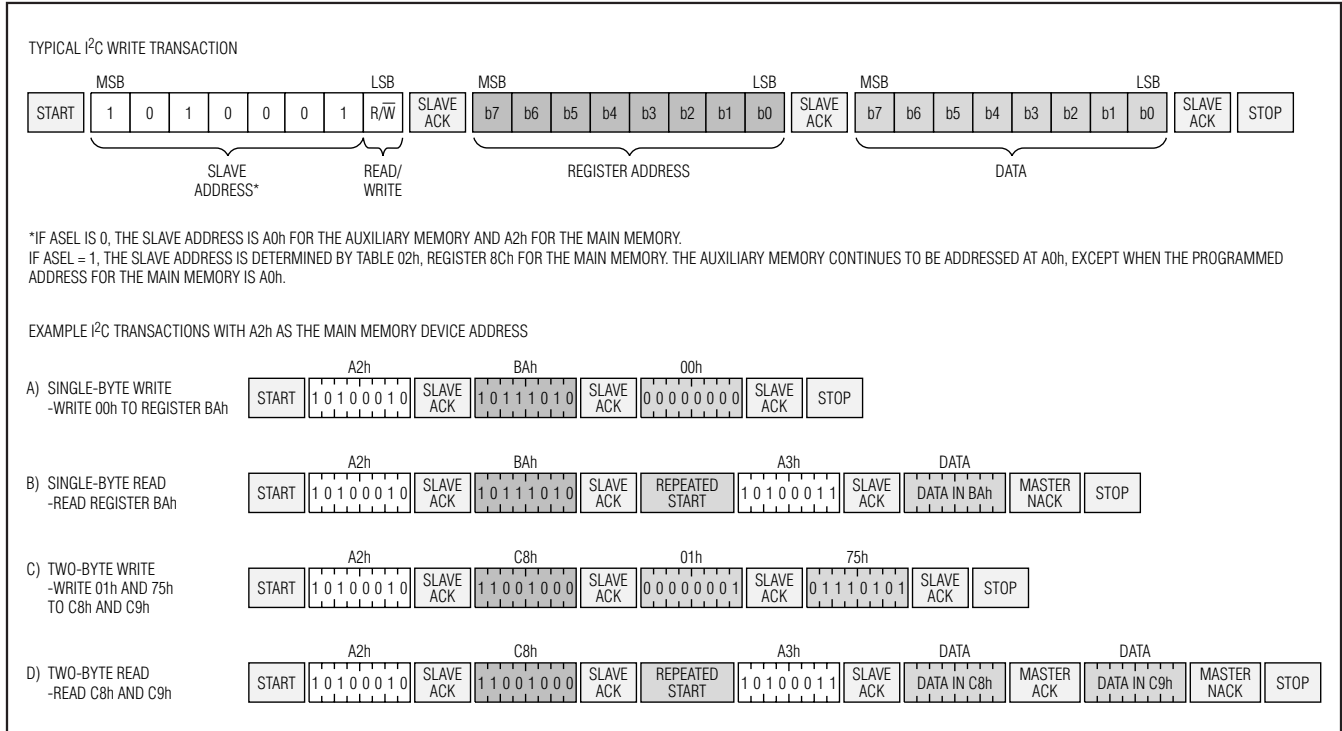

Figure 20. Example I²C Timing

cycle. This can result in a whole page being worn out over time by writing a single byte repeatedly. Writing a page one byte at a time wears the EEPROM out eight times faster than writing the entire page at once. The device's EEPROM write cycles are specified in the *Nonvolatile Memory Characteristics* table. The specification shown is at the worst-case temperature. It can handle approximately ten times that many writes at room temperature. Writing to SRAM-shadowed EEPROM memory with SEEB = 1 does not count as an EEPROM write cycle when evaluating the EEPROM's estimated lifetime.

Reading a single byte from a slave: Unlike the write operation that uses the memory address byte to define where the data is to be written, the read operation occurs at the present value of the memory address counter. To read a single byte from the slave, the master generates a START condition, writes the slave address byte with $R/\overline{W} = 1$, reads the data byte with a NACK to indicate the end of the transfer, and generates a STOP condition.

Manipulating the address counter for reads: A dummy write cycle can be used to force the address pointer to a particular value. To do this, the master generates a START condition, writes the slave

address byte ($R/\overline{W} = 0$), writes the memory address where it desires to read, generates a repeated START condition, writes the slave address byte ($R/\overline{W} = 1$), reads data with ACK or NACK as applicable, and generates a STOP condition.

Memory Organization

The device features nine separate memory tables that are internally organized into 8-byte rows.

The **Lower Memory** is addressed from 00h–7Fh and contains alarm and warning thresholds, flags, masks, several control registers, password entry area (PWE), and the table-select byte.

Table 01h primarily contains user EEPROM (with PW1 level access) as well as alarm and warning-enable bytes.

Table 02h is a multifunction space that contains configuration registers, scaling and offset values, passwords, interrupt registers as well as other miscellaneous control bytes.

Table 04h contains a temperature-indexed LUT for control of the modulation voltage. The modulation LUT can be programmed in 2°C increments over the -40°C to +102°C range.

SFP+ Controller with Digital LDD Interface

Table 05h is empty by default. It can be configured to contain the alarm- and warning-enable bytes from Table 01h, Registers F8h–FFh with the MASK bit enabled (Table 02h, Register 89h). In this case Table 01h is empty.

Table 06h contains a temperature-indexed LUT that allows the APC set point to change as a function of temperature to compensate for TE. The APC LUT has 36 entries that determine the APC setting in 4°C windows between -40°C and +100°C.

Table 07h contains a temperature-indexed LUT for control of DAC1. The LUT has 36 entries that determine the DAC setting in 4°C windows between -40°C and +100°C.

Table 08h contains a temperature-indexed LUT for control of DAC2. The LUT has 36 entries that determine the DAC setting in 4°C windows between -40°C and +100°C.

Auxiliary Memory (device A0h) contains 256 bytes of EE memory accessible from address 00h–FFh. It is selected with the device address of A0h.

See the *Register Descriptions* section for more complete details of each byte's function, as well as for read/write permissions for each byte.

Shadowed EEPROM

Many NV memory locations (listed within the *Register Descriptions* section) are actually shadowed EEPROM that are controlled by the SEEB bit in Table 02h, Register 80h.

The device incorporates shadowed-EEPROM memory locations for key memory addresses that can be written many times. By default the shadowed-EEPROM bit, SEEB, is not set and these locations act as ordinary EEPROM. By setting SEEB, these locations function like SRAM cells, which allow an infinite number of write cycles without concern of wearing out the EEPROM. Setting SEEB also eliminates the requirement for the EEPROM write time, t_{WP} . Because changes made with SEEB enabled do not affect the EEPROM, these changes are not retained through power cycles. The power-on value is the last value written with SEEB disabled. This function can be used to limit the number of EEPROM writes during calibration or to change the monitor thresholds periodically during normal operation helping to reduce the number of times EEPROM is written.

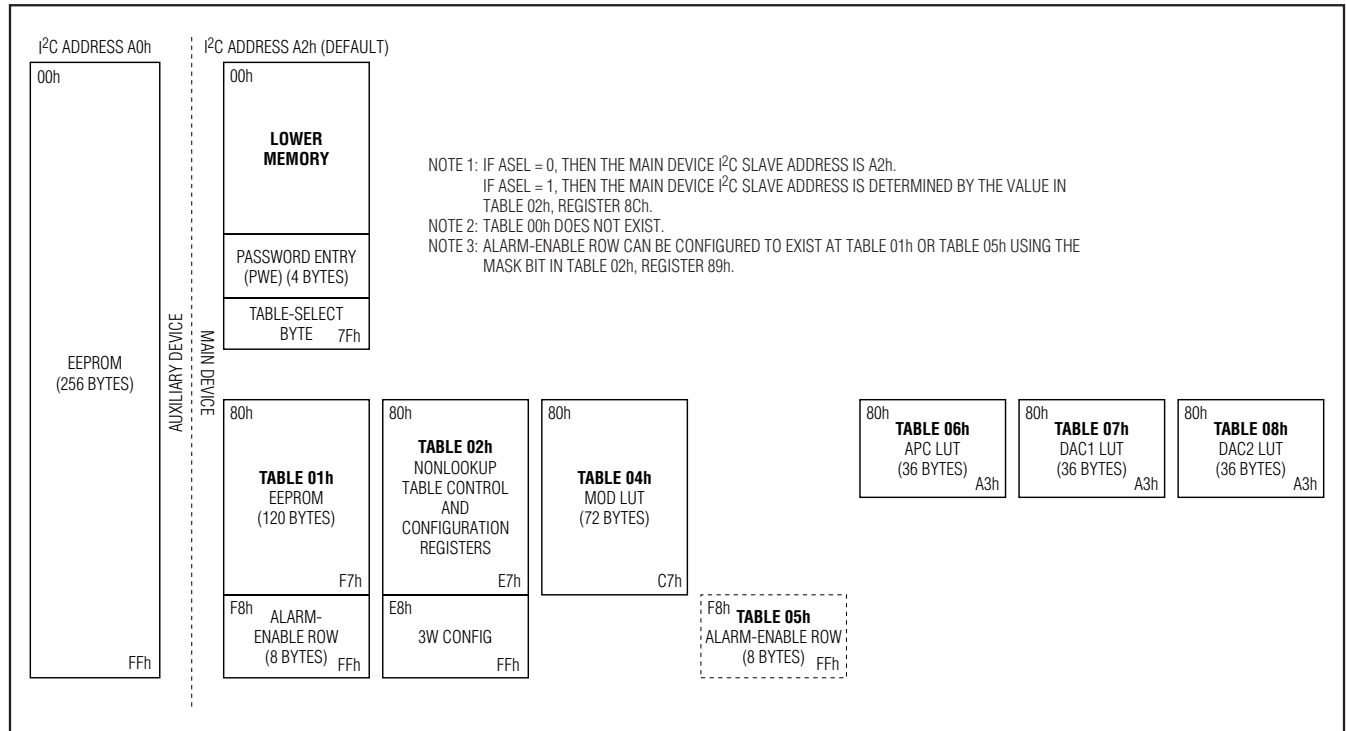

Figure 21. Memory Map

SFP+ Controller with Digital LDD Interface

Register Descriptions

The register maps show each byte/word (2 bytes) in terms of its row in the memory. The first byte in the row is located in memory at the row address (hexadecimal) in the leftmost column. Each subsequent byte on the row is one/two memory locations beyond the previous byte/word's address. A total of 8 bytes are present on each row. For more information about each of these bytes see the corresponding register description.

Lower Memory Register Map

LOWER MEMORY									
ROW (HEX)	ROW NAME	WORD 0		WORD 1		WORD 2		WORD 3	
		BYTE 0/8	BYTE 1/9	BYTE 2/A	BYTE 3/B	BYTE 4/C	BYTE 5/D	BYTE 6/E	BYTE 7/F
00	<1>THRESHOLD ₀	TEMP ALARM HI		TEMP ALARM LO		TEMP WARN HI		TEMP WARN LO	
08	<1>THRESHOLD ₁	V _{CC} ALARM HI		V _{CC} ALARM LO		V _{CC} WARN HI		V _{CC} WARN LO	
10	<1>THRESHOLD ₂	MON1 ALARM HI		MON1 ALARM LO		MON1 WARN HI		MON1 WARN LO	
18	<1>THRESHOLD ₃	MON2 ALARM HI		MON2 ALARM LO		MON2 WARN HI		MON2 WARN LO	
20	<1>THRESHOLD ₄	MON3 ALARM HI		MON3 ALARM LO		MON3 WARN HI		MON3 WARN LO	
28	<1>THRESHOLD ₅	MON4 ALARM HI		MON4 ALARM LO		MON4 WARN HI		MON4 WARN LO	
30–5F	<1>EEPROM	EE	EE	EE	EE	EE	EE	EE	EE
60	<2>ADC VALUES ₀	TEMP VALUE		V _{CC} VALUE		MON1 VALUE		MON2 VALUE	
68	<0>ADC VALUES ₁	<2>MON3 VALUE		<2>MON4 VALUE		<2>RESERVED		<0>STATUS	<3>UPDATE
70	<2>ALARM/WARN	ALARM ₃	ALARM ₂	ALARM ₁	ALARM ₀	WARN ₃	WARN ₂	RESERVED	
78	<0>TABLE SELECT	<2>RESERVED		<2>RESERVED	<6>PWE MSW		<6>PWE LSW		<5>TBL SEL

The access codes represent the factory default values of PW_ENA and PW_ENB (Table 02h, Registers C0h–C1h).

ACCESS CODE	<0>	<1>	<2>	<3>	<4>	<5>	<6>	<7>	<8>	<9>	<10>	<11>
Read Access	See each bit/byte separately	All	All	All	PW2	All	N/A	PW1	PW2	N/A	PW2	All
Write Access		PW2	N/A	All and device hardware	PW2 + mode bit	All	All	PW1	PW2	PW2	N/A	PW1

SFP+ Controller with Digital LDD Interface

Table 01h Register Map

TABLE 01h									
ROW (HEX)	ROW NAME	WORD 0		WORD 1		WORD 2		WORD 3	
		BYTE 0/8	BYTE 1/9	BYTE 2/A	BYTE 3/B	BYTE 4/C	BYTE 5/D	BYTE 6/E	BYTE 7/F
80–BF	<7>EEPROM	EE	EE	EE	EE	EE	EE	EE	EE
C0–F7	<8>EEPROM	EE	EE	EE	EE	EE	EE	EE	EE
F8	<8>ALARM ENABLE	ALARM EN ₃	ALARM EN ₂	ALARM EN ₁	ALARM EN ₀	WARN EN ₃	WARN EN ₂	RESERVED	RESERVED

The ALARM ENABLE bytes (Registers F8h–FFh) can be configured to exist in Table 05h instead of here at Table 01h with the MASK bit (Table 02h, Register 89h). If the row is configured to exist in Table 05h, then these locations are empty in Table 01h.

The access codes represent the factory default values of PW_ENA and PW_ENB (Table 02h, Registers C0h–C1h).

ACCESS CODE	<0>	<1>	<2>	<3>	<4>	<5>	<6>	<7>	<8>	<9>	<10>	<11>
Read Access	See each bit/byte separately	All	All	All	PW2	All	N/A	PW1	PW2	N/A	PW2	All
Write Access		PW2	N/A	All and device hardware	PW2 + mode bit	All	All	PW1	PW2	PW2	N/A	PW1

SFP+ Controller with Digital LDD Interface

Table 02h Register Map

DS1878

TABLE 02h (PW2)									
ROW (HEX)	ROW NAME	WORD 0		WORD 1		WORD 2		WORD 3	
		BYTE 0/8	BYTE 1/9	BYTE 2/A	BYTE 3/B	BYTE 4/C	BYTE 5/D	BYTE 6/E	BYTE 7/F
80	<0>CONFIG ₀	<8>MODE	<4>TINDEX	<4>MODULATION REGISTER		<4>DAC1 VALUE		<4>DAC2 VALUE	
88	<8>CONFIG ₁	SAMPLE RATE	CNFGA	CNFGB	CNFGC	DEVICE ADDRESS	RESERVED	RSHIFT ₁	RSHIFT ₀
90	<8>SCALE ₀	XOVER COARSE		V _{CC} SCALE		MON1 SCALE		MON2 SCALE	
98	<8>SCALE ₁	MON3 FINE SCALE		MON4 SCALE		MON3 COARSE SCALE		RESERVED	
A0	<8>OFFSET ₀	XOVER FINE		V _{CC} OFFSET		MON1 OFFSET		MON2 OFFSET	
A8	<8>OFFSET ₁	MON3 FINE OFFSET		MON4 OFFSET		MON3 COARSE OFFSET		INTERNAL TEMP OFFSET*	
B0	<9>PWD VALUE	PW1 MSW		PW1 LSW		PW2 MSW		PW2 LSW	
B8	<8>THRESHOLD	LOS RANGING	COMP RANGING	ISTEPH	ISTEPL	HXP	LXP	HLOS	LLOS
C0	<8>PWD ENABLE	PW_ENA	PW_ENB	MODTI	DAC1TI	DAC2TI	ISTEPTI	LUTTC	TBLSELPON
C8	<0>APC	<4>MAN BIAS		<4>MAN_CNTL	<10>BIAS REGISTER		<4>APC DAC	<10>DEVICE ID	<10>DEVICE VER
D0	<8>HBATH LUT	HBATH	HBATH	HBATH	HBATH	HBATH	HBATH	HBATH	HBATH
D8–E7	EMPTY	EMPTY	EMPTY	EMPTY	EMPTY	EMPTY	EMPTY	EMPTY	EMPTY
E8	<8>3W CONFIG ₀	RXCTRL1	RXCTRL2	SETCML	SETLOSL	TXCTRL	IMODMAX	IBIASMAX	SETPWCTRL
F0	<8>3W CONFIG ₁	SETTXDE	SETTXEQ	SETLOSTIMER	SETLOSH	RXCTRL3	TXCTRL2	TXCTRL3	3WSET
F8	<0>3W CONFIG ₂	<8>3WCTRL	<8>ADDRESS	<8>WRITE	<10>READ	<10>TXSTAT1	<10>TXSTAT2	RESERVED	RESERVED

*The final result must be XORed with BB40h before writing to this register.

*Do not write to this register.

The access codes represent the factory default values of PW_ENA and PW_ENB (Table 02h, Registers C0h–C1h).

ACCESS CODE	<0>	<1>	<2>	<3>	<4>	<5>	<6>	<7>	<8>	<9>	<10>	<11>
Read Access	See each bit/byte separately	All	All	All	PW2	All	N/A	PW1	PW2	N/A	PW2	All
Write Access		PW2	N/A	All and device hardware	PW2 + mode bit	All	All	PW1	PW2	PW2	N/A	PW1

SFP+ Controller with Digital LDD Interface

Table 04h Register Map

TABLE 04h (MODULATION LUT)									
ROW (HEX)	ROW NAME	WORD 0		WORD 1		WORD 2		WORD 3	
		BYTE 0/8	BYTE 1/9	BYTE 2/A	BYTE 3/B	BYTE 4/C	BYTE 5/D	BYTE 6/E	BYTE 7/F
80–C7	<8>LUT4	MOD	MOD	MOD	MOD	MOD	MOD	MOD	MOD

Table 05h Register Map

TABLE 05h									
ROW (HEX)	ROW NAME	WORD 0		WORD 1		WORD 2		WORD 3	
		BYTE 0/8	BYTE 1/9	BYTE 2/A	BYTE 3/B	BYTE 4/C	BYTE 5/D	BYTE 6/E	BYTE 7/F
80–F7	EMPTY	EMPTY	EMPTY	EMPTY	EMPTY	EMPTY	EMPTY	EMPTY	EMPTY
F8	<8>ALARM ENABLE	ALARM EN ₃	ALARM EN ₂	ALARM EN ₁	ALARM EN ₀	WARN EN ₃	WARN EN ₂	RESERVED	RESERVED

Table 05h is empty by default. It can be configured to contain the alarm and warning-enable bytes from Table 01h, Registers F8h–FFh with the MASK bit enabled (Table 02h, Register 89h). In this case Table 01h is empty.

Table 06h Register Map

TABLE 06h (APC LUT)									
ROW (HEX)	ROW NAME	WORD 0		WORD 1		WORD 2		WORD 3	
		BYTE 0/8	BYTE 1/9	BYTE 2/A	BYTE 3/B	BYTE 4/C	BYTE 5/D	BYTE 6/E	BYTE 7/F
80–9F	<8>APC LUT	APC REF	APC REF	APC REF	APC REF	APC REF	APC REF	APC REF	APC REF
A0	<8>APC LUT	APC REF	APC REF	APC REF	APC REF	RESERVED	RESERVED	RESERVED	RESERVED

The access codes represent the factory default values of PW_ENA and PW_ENB (Table 02h, Registers C0h–C1h).

ACCESS CODE	<0>	<1>	<2>	<3>	<4>	<5>	<6>	<7>	<8>	<9>	<10>	<11>
Read Access	See each bit/byte separately	All	All	All	PW2	All	N/A	PW1	PW2	N/A	PW2	All
Write Access		PW2	N/A	All and device hardware	PW2 + mode bit	All	All	PW1	PW2	PW2	N/A	PW1

SFP+ Controller with Digital LDD Interface

DS1878

Table 07h Register Map

TABLE 07h (DAC1 LUT)									
ROW (HEX)	ROW NAME	WORD 0		WORD 1		WORD 2		WORD 3	
		BYTE 0/8	BYTE 1/9	BYTE 2/A	BYTE 3/B	BYTE 4/C	BYTE 5/D	BYTE 6/E	BYTE 7/F
80–9F	<8>LUT7	DAC1	DAC1	DAC1	DAC1	DAC1	DAC1	DAC1	DAC1
A0	<8>LUT7	DAC1	DAC1	DAC1	DAC1	RESERVED	RESERVED	RESERVED	RESERVED

Table 08h Register Map

TABLE 08h (DAC2 LUT)									
ROW (HEX)	ROW NAME	WORD 0		WORD 1		WORD 2		WORD 3	
		BYTE 0/8	BYTE 1/9	BYTE 2/A	BYTE 3/B	BYTE 4/C	BYTE 5/D	BYTE 6/E	BYTE 7/F
80–9F	<8>LUT8	DAC2	DAC2	DAC2	DAC2	DAC2	DAC2	DAC2	DAC2
A0	<8>LUT8	DAC2	DAC2	DAC2	DAC2	RESERVED	RESERVED	RESERVED	RESERVED

Auxiliary A0h Memory Register Map

AUXILIARY MEMORY (A0h)									
ROW (HEX)	ROW NAME	WORD 0		WORD 1		WORD 2		WORD 3	
		BYTE 0/8	BYTE 1/9	BYTE 2/A	BYTE 3/B	BYTE 4/C	BYTE 5/D	BYTE 6/E	BYTE 7/F
00–FF	<5>AUX EE	EE	EE	EE	EE	EE	EE	EE	EE

The access codes represent the factory default values of PW_ENA and PW_ENB (Table 02h, Registers C0h–C1h).

ACCESS CODE	<0>	<1>	<2>	<3>	<4>	<5>	<6>	<7>	<8>	<9>	<10>	<11>
Read Access	See each bit/byte separately	All	All	All	PW2	All	N/A	PW1	PW2	N/A	PW2	All
Write Access		PW2	N/A	All and device hardware	PW2 + mode bit	All	All	PW1	PW2	PW2	N/A	PW1

SFP+ Controller with Digital LDD Interface

Lower Memory Register Descriptions

Lower Memory, Register 00h–01h: TEMP ALARM HI

Lower Memory, Register 04h–05h: TEMP WARN HI

FACTORY DEFAULT	7FFFh
READ ACCESS	All
WRITE ACCESS	PW2
MEMORY TYPE	Nonvolatile (SEE)

00h, 04h	S	2^6	2^5	2^4	2^3	2^2	2^1	2^0
01h, 05h	2^{-1}	2^{-2}	2^{-3}	2^{-4}	2^{-5}	2^{-6}	2^{-7}	2^{-8}
	BIT 7							BIT 0

Temperature measurement updates above this two's complement threshold set corresponding alarm or warning bits. Temperature measurement updates equal to or below this threshold clear alarm or warning bits.

Lower Memory, Register 02h–03h: TEMP ALARM LO

Lower Memory, Register 06h–07h: TEMP WARN LO

FACTORY DEFAULT	8000h
READ ACCESS	All
WRITE ACCESS	PW2
MEMORY TYPE	Nonvolatile (SEE)

02h, 06h	S	2^6	2^5	2^4	2^3	2^2	2^1	2^0
03h, 07h	2^{-1}	2^{-2}	2^{-3}	2^{-4}	2^{-5}	2^{-6}	2^{-7}	2^{-8}
	BIT 7							BIT 0

Temperature measurement updates below this two's complement threshold set corresponding alarm or warning bits. Temperature measurement updates equal to or above this threshold clear alarm or warning bits.

SFP+ Controller with Digital LDD Interface

- Lower Memory, Register 08h–09h: V_{CC} ALARM HI
- Lower Memory, Register 0Ch–0Dh: V_{CC} WARN HI
- Lower Memory, Register 10h–11h: MON1 ALARM HI
- Lower Memory, Register 14h–15h: MON1 WARN HI
- Lower Memory, Register 18h–19h: MON2 ALARM HI
- Lower Memory, Register 1Ch–1Dh: MON2 WARN HI
- Lower Memory, Register 20h–21h: MON3 ALARM HI
- Lower Memory, Register 24h–25h: MON3 WARN HI
- Lower Memory, Register 28h–29h: MON4 ALARM HI
- Lower Memory, Register 2Ch–2Dh: MON4 WARN HI

FACTORY DEFAULT FFFFh
 READ ACCESS All
 WRITE ACCESS PW2
 MEMORY TYPE Nonvolatile (SEE)

08h, 0Ch, 10h, 14h, 18h, 1Ch, 20h, 24h, 28h, 2Ch	2 ¹⁵	2 ¹⁴	2 ¹³	2 ¹²	2 ¹¹	2 ¹⁰	2 ⁹	2 ⁸
09h, 0Dh, 11h, 15h, 19h, 1Dh, 21h, 25h, 29h, 2Dh	2 ⁷	2 ⁶	2 ⁵	2 ⁴	2 ³	2 ²	2 ¹	2 ⁰
	BIT 7							BIT 0

Voltage measurement updates above this unsigned threshold set corresponding alarm or warning bits. Voltage measurements equal to or below this threshold clear alarm or warning bits.

SFP+ Controller with Digital LDD Interface

- Lower Memory, Register 0Ah–0Bh: V_{CC} ALARM LO
- Lower Memory, Register 0Eh–0Fh: V_{CC} WARN LO
- Lower Memory, Register 12h–13h: MON1 ALARM LO
- Lower Memory, Register 16h–17h: MON1 WARN LO
- Lower Memory, Register 1Ah–1Bh: MON2 ALARM LO
- Lower Memory, Register 1Eh–1Fh: MON2 WARN LO
- Lower Memory, Register 22h–23h: MON3 ALARM LO
- Lower Memory, Register 26h–27h: MON3 WARN LO
- Lower Memory, Register 2Ah–2Bh: MON4 ALARM LO
- Lower Memory, Register 2Eh–2Fh: MON4 WARN LO

FACTORY DEFAULT	0000h
READ ACCESS	All
WRITE ACCESS	PW2
MEMORY TYPE	Nonvolatile (SEE)

0Ah, 0Eh, 12h, 16h, 1Ah, 1Eh, 22h, 26h, 2Ah, 2Eh	2 ¹⁵	2 ¹⁴	2 ¹³	2 ¹²	2 ¹¹	2 ¹⁰	2 ⁹	2 ⁸
0Bh, 0Fh, 13h, 17h, 1Bh, 1Fh, 23h, 27h, 2Bh, 2Fh	2 ⁷	2 ⁶	2 ⁵	2 ⁴	2 ³	2 ²	2 ¹	2 ⁰
	BIT 7							BIT 0

Voltage measurement updates below this unsigned threshold set corresponding alarm or warning bits. Voltage measurements equal to or above this threshold clear alarm or warning bits.

SFP+ Controller with Digital LDD Interface

Lower Memory, Register 30h–5Fh: EE

FACTORY DEFAULT	00h
READ ACCESS	All
WRITE ACCESS	PW2
MEMORY TYPE	Nonvolatile (EE)

30h–5Fh	EE	EE	EE	EE	EE	EE	EE	EE
	BIT 7							BIT 0

PW2 level access-controlled EEPROM.

Lower Memory, Register 60h–61h: TEMP VALUE

POWER-ON VALUE	0000h
READ ACCESS	All
WRITE ACCESS	N/A
MEMORY TYPE	Volatile

60h	S	2^6	2^5	2^4	2^3	2^2	2^1	2^0
61h	2^{-1}	2^{-2}	2^{-3}	2^{-4}	2^{-5}	2^{-6}	2^{-7}	2^{-8}
	BIT 7							BIT 0

Signed two's complement direct-to-temperature measurement.

SFP+ Controller with Digital LDD Interface

Lower Memory, Register 62h–63h: VCC VALUE
 Lower Memory, Register 64h–65h: MON1 VALUE
 Lower Memory, Register 66h–67h: MON2 VALUE
 Lower Memory, Register 68h–69h: MON3 VALUE
 Lower Memory, Register 6Ah–6Bh: MON4 VALUE

POWER-ON VALUE 0000h
 READ ACCESS All
 WRITE ACCESS N/A
 MEMORY TYPE Volatile

62h, 64h, 66h, 68h, 6Ah	2 ¹⁵	2 ¹⁴	2 ¹³	2 ¹²	2 ¹¹	2 ¹⁰	2 ⁹	2 ⁸
63h, 65h, 67h, 69h, 6Bh	2 ⁷	2 ⁶	2 ⁵	2 ⁴	2 ³	2 ²	2 ¹	2 ⁰
	BIT 7							BIT 0

Left-justified unsigned voltage measurement.

Lower Memory, Register 6Ch–6Dh: RESERVED

POWER-ON VALUE 00h
 READ ACCESS All
 WRITE ACCESS N/A
 MEMORY TYPE

These registers are reserved.

SFP+ Controller with Digital LDD Interface

Lower Memory, Register 6Eh: STATUS

POWER-ON VALUE	X0XX 0XXXb
READ ACCESS	All
WRITE ACCESS	See below
MEMORY TYPE	Volatile

Write Access	N/A	All	N/A	All	All	N/A	N/A	N/A	
6Eh	TXDS	TXDC	IN1S	RSELS	RSELC	TXFOUTS	RXL	RDYB	
	BIT 7								BIT 0

BIT 7	TXDS: TXD Status Bit. Reflects the logic state of the TXD pin (read only). 0 = TXD pin is logic-low. 1 = TXD pin is logic-high.
BIT 6	TXDC: TXD Software Control Bit. This bit allows for software control that is identical to the TXD pin. See the section on TXD for further information. Its value is wire-ORed with the logic value of the TXD pin (writable by all users). 0 = (Default). 1 = Forces the device into a TXD state regardless of the value of the TXD pin.
BIT 5	IN1S: IN1 Status Bit. Reflects the logic state of the IN1 pin (read only). 0 = IN1 pin is logic-low. 1 = IN1 pin is logic-high.
BIT 4	RSELS: RSEL Status Bit. Reflects the logic state of the RSEL pin (read only). 0 = RSEL pin is logic-low. 1 = RSEL pin is logic-high.
BIT 3	RSELC: RSEL Software Control Bit. This bit allows for software control that is identical to the RSEL pin. Its value is wire-ORed with the logic value of the RSEL pin to create the RSELOUT pin's logic value (writable by all users). 0 = (Default). 1 = Forces the device into a RSEL state regardless of the value of the RSEL pin.
BIT 2	TXFOUTS: TXFOUT Status. Indicates the state the open-drain output is attempting to achieve. 0 = TXFOUT is pulling low. 1 = TXFOUT is high impedance.
BIT 1	RXL: Reflects the driven state of the LOSOUT pin (read only). 0 = LOSOUT pin is driven low. 1 = LOSOUT pin is pulled high.
BIT 0	RDYB: Ready Bar. 0 = V _{CC} is above POA. 1 = V _{CC} is below POA and/or too low to communicate over the I ² C bus.

SFP+ Controller with Digital LDD Interface

Lower Memory, Register 6Fh: UPDATE

POWER-ON VALUE	00h
READ ACCESS	All
WRITE ACCESS	All and device hardware
MEMORY TYPE	Volatile

6Fh	TEMP RDY	VCC RDY	MON1 RDY	MON2 RDY	MON3 RDY	MON4 RDY	RESERVED	RSSIR
	BIT 7							BIT 0

BITS 7:2	Update of completed conversions. At power-on, these bits are cleared and are set as each conversion is completed. These bits can be cleared so that a completion of a new conversion is verified.
BIT 1	RESERVED
BIT 0	RSSIR: RSSI Range. Reports the range used for conversion update of MON3. 0 = Fine range is the reported value. 1 = Coarse range is the reported value.

SFP+ Controller with Digital LDD Interface

Lower Memory, Register 70h: ALARM₃

POWER-ON VALUE	10h
READ ACCESS	All
WRITE ACCESS	N/A
MEMORY TYPE	Volatile

70h	TEMP HI	TEMP LO	VCC HI	VCC LO	MON1 HI	MON1 LO	MON2 HI	MON2 LO
	BIT 7							BIT 0

BIT 7	TEMP HI: High-alarm status for temperature measurement. 0 = (Default) Last measurement was equal to or below threshold setting. 1 = Last measurement was above threshold setting.
BIT 6	TEMP LO: Low-alarm status for temperature measurement. 0 = (Default) Last measurement was equal to or above threshold setting. 1 = Last measurement was below threshold setting.
BIT 5	VCC HI: High-alarm status for V _{CC} measurement. 0 = (Default) Last measurement was equal to or below threshold setting. 1 = Last measurement was above threshold setting.
BIT 4	VCC LO: Low-alarm status for V _{CC} measurement. This bit is set when the V _{CC} supply is below the POA trip point value. It clears itself when a V _{CC} measurement is completed and the value is above the low threshold. 0 = Last measurement was equal to or above threshold setting. 1 = (Default) Last measurement was below threshold setting.
BIT 3	MON1 HI: High-alarm status for MON1 measurement. 0 = (Default) Last measurement was equal to or below threshold setting. 1 = Last measurement was above threshold setting.
BIT 2	MON1 LO: Low-alarm status for MON1 measurement. 0 = (Default) Last measurement was equal to or above threshold setting. 1 = Last measurement was below threshold setting.
BIT 1	MON2 HI: High-alarm status for MON2 measurement. 0 = (Default) Last measurement was equal to or below threshold setting. 1 = Last measurement was above threshold setting.
BIT 0	MON2 LO: Low-alarm status for MON2 measurement. 0 = (Default) Last measurement was equal to or above threshold setting. 1 = Last measurement was below threshold setting.

SFP+ Controller with Digital LDD Interface

Lower Memory, Register 71h: ALARM₂

POWER-ON VALUE	00h
READ ACCESS	All
WRITE ACCESS	N/A
MEMORY TYPE	Volatile

71h	MON3 HI	MON3 LO	MON4 HI	MON4 LO	RESERVED	TXFS	FETG	TXFINT
	BIT 7							BIT 0

BIT 7	MON3 HI: High-alarm status for MON3 measurement. A TXD event does not clear this alarm. 0 = (Default) Last measurement was equal to or below threshold setting. 1 = Last measurement was above threshold setting.
BIT 6	MON3 LO: Low-alarm status for MON3 measurement. A TXD event does not clear this alarm. 0 = (Default) Last measurement was equal to or above threshold setting. 1 = Last measurement was below threshold setting.
BIT 5	MON4 HI: High-alarm status for MON4 measurement. A TXD event does not clear this alarm. 0 = (Default) Last measurement was equal to or below threshold setting. 1 = Last measurement was above threshold setting.
BIT 4	MON4 LO: Low-alarm status for MON4 measurement. A TXD event does not clear this alarm. 0 = (Default) Last measurement was equal to or above threshold setting. 1 = Last measurement was below threshold setting.
BIT 3	RESERVED
BIT 2	TXFS: Reflects the status of the TXF pin. The status also includes any inversion caused by the INVTXF bit (read only). 0 = TXF pin is low (after any inversion caused by the INVTXF bit). 1 = TXF pin is high (after any inversion caused by the INVTXF bit).
BIT 1	FETG: Status of Internal Signal FETG. The FETG signal is part of the internal shutdown logic. 0 = FETG is low. 1 = FETG is high.
BIT 0	TXFINT: TXFOUT Interrupt. This bit is the wire-ORed logic of all alarms and warnings wire-ANDed with their corresponding enable bits in addition to nonmaskable alarms TXP HI, TXP LO, BIAS MAX, and HBAL. The enable bits are found in Table 01h/05h, Registers F8h–FFh.

SFP+ Controller with Digital LDD Interface

Lower Memory, Register 72h: ALARM₁

POWER-ON VALUE	00h
READ ACCESS	All
WRITE ACCESS	N/A
MEMORY TYPE	Volatile

72h	RESERVED	RESERVED	RESERVED	RESERVED	HBAL	RESERVED	TXP HI	TXP LO
	BIT 7							BIT 0

BITS 7:4	RESERVED
BIT 3	HBAL: High-Bias Alarm Status; Fast Comparison. A TXD event clears this alarm. 0 = (Default) Last comparison was below threshold setting. 1 = Last comparison was above threshold setting.
BIT 2	RESERVED
BIT 1	TXP HI: High-Alarm Status TXP; Fast Comparison. A TXD event clears this alarm. 0 = (Default) Last comparison was below threshold setting. 1 = Last comparison was above threshold setting.
BIT 0	TXP LO: Low-Alarm Status TXP; Fast Comparison. A TXD event clears this alarm. 0 = (Default) Last comparison was above threshold setting. 1 = Last comparison was below threshold setting.

SFP+ Controller with Digital LDD Interface

Lower Memory, Register 73h: ALARM₀

POWER-ON VALUE	00h
READ ACCESS	All
WRITE ACCESS	N/A
MEMORY TYPE	Volatile

73h	LOS HI	LOS LO	RESERVED	RESERVED	BIAS MAX	RESERVED	RESERVED	RESERVED
	BIT 7							BIT 0

BIT 7	<p>LOS HI: High-Alarm Status for MON3; Fast Comparison. A TXD event does not clear this alarm. 0 = (Default) At POR, this is the state if the last comparison was below the HLOS threshold setting. See the description of the set condition to determine what causes LOS HI to be reset. 1 = Last comparison was above the HLOS threshold setting. LOS HI stays set until the time MON3 goes below the LLOS level, or a POR to the device causes LOS HI to reset if it is below the HLOS threshold.</p>
BIT 6	<p>LOS LO: Low-Alarm Status for MON3; Fast Comparison. A TXD event does not clear this alarm. 0 = (Default) At POR, this is the state if the last comparison was above the LLOS threshold setting. See the description of the set condition to determine what causes LOS LO to be reset. 1 = Last comparison was below the LLOS threshold setting. LOS LO stays set until the time MON3 goes above the HLOS level, or a POR to the device causes LOS LO to reset if it is below the LLOS threshold.</p>
BITS 5:4	RESERVED
BIT 3	<p>BIAS MAX: Alarm status for maximum digital setting of BIAS. A TXD event clears this alarm. 0 = (Default) The value for BIAS is equal to or below the IBIASMAX register. 1 = Requested value for BIAS is greater than the IBIASMAX register.</p>
BITS 2:0	RESERVED

SFP+ Controller with Digital LDD Interface

Lower Memory, Register 74h: WARN₃

POWER-ON VALUE	10h
READ ACCESS	All
WRITE ACCESS	N/A
MEMORY TYPE	Volatile

74h	TEMP HI	TEMP LO	VCC HI	VCC LO	MON1 HI	MON1 LO	MON2 HI	MON2 LO
	BIT 7				BIT 0			

BIT 7	TEMP HI: High-warning status for temperature measurement. 0 = (Default) Last measurement was equal to or below threshold setting. 1 = Last measurement was above threshold setting.
BIT 6	TEMP LO: Low-warning status for temperature measurement. 0 = (Default) Last measurement was equal to or above threshold setting. 1 = Last measurement was below threshold setting.
BIT 5	VCC HI: High-warning status for V _{CC} measurement. 0 = (Default) Last measurement was equal to or below threshold setting. 1 = Last measurement was above threshold setting.
BIT 4	VCC LO: Low-warning status for V _{CC} measurement. This bit is set when the V _{CC} supply is below the POA trip point value. It clears itself when a V _{CC} measurement is completed and the value is above the low threshold. 0 = Last measurement was equal to or above threshold setting. 1 = (Default) Last measurement was below threshold setting.
BIT 3	MON1 HI: High-warning status for MON1 measurement. 0 = (Default) Last measurement was equal to or below threshold setting. 1 = Last measurement was above threshold setting.
BIT 2	MON1 LO: Low-warning status for MON1 measurement. 0 = (Default) Last measurement was equal to or above threshold setting. 1 = Last measurement was below threshold setting.
BIT 1	MON2 HI: High-warning status for MON2 measurement. 0 = (Default) Last measurement was equal to or below threshold setting. 1 = Last measurement was above threshold setting.
BIT 0	MON2 LO: Low-warning status for MON2 measurement. 0 = (Default) Last measurement was equal to or above threshold setting. 1 = Last measurement was below threshold setting.

SFP+ Controller with Digital LDD Interface

Lower Memory, Register 75h: WARN₂

POWER-ON VALUE	00h
READ ACCESS	All
WRITE ACCESS	N/A
MEMORY TYPE	Volatile

75h	MON3 HI	MON3 LO	MON4 HI	MON4 LO	RESERVED	RESERVED	RESERVED	RESERVED
	BIT 7				BIT 0			

BIT 7	MON3 HI: High-warning status for MON3 measurement. 0 = (Default) Last measurement was equal to or below threshold setting. 1 = Last measurement was above threshold setting.
BIT 6	MON3 LO: Low-warning status for MON3 measurement. 0 = (Default) Last measurement was equal to or above threshold setting. 1 = Last measurement was below threshold setting.
BIT 5	MON4 HI: High-warning status for MON4 measurement. 0 = (Default) Last measurement was equal to or below threshold setting. 1 = Last measurement was above threshold setting.
BIT 4	MON4 LO: Low-warning status for MON4 measurement. 0 = (Default) Last measurement was equal to or above threshold setting. 1 = Last measurement was below threshold setting.
BITS 3:0	RESERVED

Lower Memory, Register 76h–7Ah: RESERVED

POWER-ON VALUE	00h
READ ACCESS	N/A
WRITE ACCESS	N/A
MEMORY TYPE	

These registers are reserved.

SFP+ Controller with Digital LDD Interface

Lower Memory, Register 7Bh–7Eh: PASSWORD ENTRY (PWE)

POWER-ON VALUE	FFFF FFFFh
READ ACCESS	N/A
WRITE ACCESS	All
MEMORY TYPE	Volatile

7Bh	2^{31}	2^{30}	2^{29}	2^{28}	2^{27}	2^{26}	2^{25}	2^{24}
7Ch	2^{23}	2^{22}	2^{21}	2^{20}	2^{19}	2^{18}	2^{17}	2^{16}
7Dh	2^{15}	2^{14}	2^{13}	2^{12}	2^{11}	2^{10}	2^9	2^8
7Eh	2^7	2^6	2^5	2^4	2^3	2^2	2^1	2^0
	BIT 7				BIT 0			

There are two passwords for the device. Each password is 4 bytes long. The lower level password (PW1) has all the access of a normal user plus those made available with PW1. The higher level password (PW2) has all the access of PW1 plus those made available with PW2. The values of the passwords reside in EEPROM inside PW2 memory. At power-up, all PWE bits are set to 1. All reads at this location are 0.

Lower Memory, Register 7Fh: TABLE SELECT (TBL SEL)

POWER-ON VALUE	TBLSELPON (Table 02h, Register C7h)
READ ACCESS	All
WRITE ACCESS	All
MEMORY TYPE	Volatile

7Fh	2^7	2^6	2^5	2^4	2^3	2^2	2^1	2^0
	BIT 7				BIT 0			

The upper memory tables of the device are accessible by writing the desired table value in this register. The power-on value of this register is defined by the value written to TBLSELPON (Table 02h, Register C7h).

SFP+ Controller with Digital LDD Interface

Table 01h Register Descriptions

Table 01h, Register 80h–BFh: EEPROM

POWER-ON VALUE	00h
READ ACCESS	PW2 or (PW1 and RWTBL1A) or (PW1 and RTBL1A)
WRITE ACCESS	PW2 or (PW1 and RWTBL1A)
MEMORY TYPE	Nonvolatile (EE)

80h–BFh	EE	EE	EE	EE	EE	EE	EE	EE
	BIT 7							BIT 0

EEPROM for PW1 and/or PW2 level access.

Table 01h, Register C0h–F7h: EEPROM

POWER-ON VALUE	00h
READ ACCESS	PW2 or (PW1 and RWTBL1B) or (PW1 and RTBL1B)
WRITE ACCESS	PW2 or (PW1 and RWTBL1B)
MEMORY TYPE	Nonvolatile (EE)

C0h–F7h	EE	EE	EE	EE	EE	EE	EE	EE
	BIT 7							BIT 0

EEPROM for PW1 and/or PW2 level access.

SFP+ Controller with Digital LDD Interface

Table 01h, Register F8h: ALARM EN₃

POWER-ON VALUE	00h
READ ACCESS	PW2 or (PW1 and RWTBL1C) or (PW1 and RTBL1C)
WRITE ACCESS	PW2 or (PW1 and RWTBL1C)
MEMORY TYPE	Nonvolatile (SEE)

F8h	TEMP HI	TEMP LO	VCC HI	VCC LO	MON1 HI	MON1 LO	MON2 HI	MON2 LO
	BIT 7							BIT 0

Layout is identical to ALARM₃ in Lower Memory, Register 70h. Enables alarms to create TXFINT (Lower Memory, Register 71h) logic. The MASK bit (Table 02h, Register 89h) determines whether this memory exists in Table 01h or 05h.

BIT 7	TEMP HI: 0 = Disables interrupt from TEMP HI alarm. 1 = Enables interrupt from TEMP HI alarm.
BIT 6	TEMP LO: 0 = Disables interrupt from TEMP LO alarm. 1 = Enables interrupt from TEMP LO alarm.
BIT 5	VCC HI: 0 = Disables interrupt from VCC HI alarm. 1 = Enables interrupt from VCC HI alarm.
BIT 4	VCC LO: 0 = Disables interrupt from VCC LO alarm. 1 = Enables interrupt from VCC LO alarm.
BIT 3	MON1 HI: 0 = Disables interrupt from MON1 HI alarm. 1 = Enables interrupt from MON1 HI alarm.
BIT 2	MON1 LO: 0 = Disables interrupt from MON1 LO alarm. 1 = Enables interrupt from MON1 LO alarm.
BIT 1	MON2 HI: 0 = Disables interrupt from MON2 HI alarm. 1 = Enables interrupt from MON2 HI alarm.
BIT 0	MON2 LO: 0 = Disables interrupt from MON2 LO alarm. 1 = Enables interrupt from MON2 LO alarm.

SFP+ Controller with Digital LDD Interface

Table 01h, Register F9h: ALARM EN₂

POWER-ON VALUE	00h
READ ACCESS	PW2 or (PW1 and RWTBL1C) or (PW1 and RTBL1C)
WRITE ACCESS	PW2 or (PW1 and RWTBL1C)
MEMORY TYPE	Nonvolatile (SEE)

F9h	MON3 HI	MON3 LO	MON4 HI	MON4 LO	RESERVED	RESERVED	RESERVED	RESERVED
	BIT 7							BIT 0

Layout is identical to ALARM₂ in Lower Memory, Register 71h. Enables alarms to create TXFINT (Lower Memory, Register 71h) logic. The MASK bit (Table 02h, Register 89h) determines whether this memory exists in Table 01h or 05h.

BIT 7	MON3 HI: 0 = Disables interrupt from MON3 HI alarm. 1 = Enables interrupt from MON3 HI alarm.
BIT 6	MON3 LO: 0 = Disables interrupt from MON3 LO alarm. 1 = Enables interrupt from MON3 LO alarm.
BIT 5	MON4 HI: 0 = Disables interrupt from MON4 HI alarm. 1 = Enables interrupt from MON4 HI alarm.
BIT 4	MON4 LO: 0 = Disables interrupt from MON4 LO alarm. 1 = Enables interrupt from MON4 LO alarm.
BIT 3:0	RESERVED

SFP+ Controller with Digital LDD Interface

Table 01h, Register FAh: ALARM EN₁

POWER-ON VALUE	00h
READ ACCESS	PW2 or (PW1 and RWTBL1C) or (PW1 and RTBL1C)
WRITE ACCESS	PW2 or (PW1 and RWTBL1C)
MEMORY TYPE	Nonvolatile (SEE)

FAh	RESERVED	RESERVED	RESERVED	RESERVED	HBAL	RESERVED	TXP HI	TXP LO
	BIT 7							BIT 0

Layout is identical to ALARM₁ in Lower Memory, Register 72h. Enables alarms to create internal signal FETG (see Figure 14) logic. The MASK bit (Table 02h, Register 89h) determines whether this memory exists in Table 01h or 05h.

BITS 7:4	RESERVED
BIT 3	HBAL: 0 = Disables interrupt from HBAL alarm. 1 = Enables interrupt from HBAL alarm.
BIT 2	RESERVED
BIT 1	TXP HI: 0 = Disables interrupt from TXP HI alarm. 1 = Enables interrupt from TXP HI alarm.
BIT 0	TXP LO: 0 = Disables interrupt from TXP LO alarm. 1 = Enables interrupt from TXP LO alarm.

SFP+ Controller with Digital LDD Interface

Table 01h, Register FBh: ALARM EN₀

POWER-ON VALUE	00h
READ ACCESS	PW2 or (PW1 and RWTBL1C) or (PW1 and RTBL1C)
WRITE ACCESS	PW2 or (PW1 and RWTBL1C)
MEMORY TYPE	Nonvolatile (SEE)

FBh	LOS HI	LOS LO	RESERVED	RESERVED	BIAS MAX	RESERVED	RESERVED	RESERVED
	BIT 7							BIT 0

Layout is identical to ALARM₀ in Lower Memory, Register 73h. The MASK bit (Table 02h, Register 89h) determines whether this memory exists in Table 01h or 05h.

BIT 7	LOS HI: Enables alarm to create TXFINT (Lower Memory, Register 71h) logic. 0 = Disables interrupt from LOS HI alarm. 1 = Enables interrupt from LOS HI alarm.
BIT 6	LOS LO: Enables alarm to create TXFINT (Lower Memory, Register 71h) logic. 0 = Disables interrupt from LOS LO alarm. 1 = Enables interrupt from LOS LO alarm.
BITS 5:4	RESERVED
BIT 3	BIAS MAX: Enables alarm to create internal signal FETG (see Figure 14) logic. 0 = Disables interrupt from BIAS MAX alarm. 1 = Enables interrupt from BIAS MAX alarm.
BITS 2:0	RESERVED

SFP+ Controller with Digital LDD Interface

Table 01h, Register FCh: WARN EN₃

POWER-ON VALUE	00h
READ ACCESS	PW2 or (PW1 and RWTBL1C) or (PW1 and RTBL1C)
WRITE ACCESS	PW2 or (PW1 and RWTBL1C)
MEMORY TYPE	Nonvolatile (SEE)

F8h	TEMP HI	TEMP LO	VCC HI	VCC LO	MON1 HI	MON1 LO	MON2 HI	MON2 LO
	BIT 7							BIT 0

Layout is identical to WARN₃ in Lower Memory, Register 74h. Enables warnings to create TXFINT (Lower Memory, Register 71h) logic. The MASK bit (Table 02h, Register 89h) determines whether this memory exists in Table 01h or 05h.

BIT 7	TEMP HI: 0 = Disables interrupt from TEMP HI warning. 1 = Enables interrupt from TEMP HI warning.
BIT 6	TEMP LO: 0 = Disables interrupt from TEMP LO warning. 1 = Enables interrupt from TEMP LO warning.
BIT 5	VCC HI: 0 = Disables interrupt from VCC HI warning. 1 = Enables interrupt from VCC HI warning.
BIT 4	VCC LO: 0 = Disables interrupt from VCC LO warning. 1 = Enables interrupt from VCC LO warning.
BIT 3	MON1 HI: 0 = Disables interrupt from MON1 HI warning. 1 = Enables interrupt from MON1 HI warning.
BIT 2	MON1 LO: 0 = Disables interrupt from MON1 LO warning. 1 = Enables interrupt from MON1 LO warning.
BIT 1	MON2 HI: 0 = Disables interrupt from MON2 HI warning. 1 = Enables interrupt from MON2 HI warning.
BIT 0	MON2 LO: 0 = Disables interrupt from MON2 LO warning. 1 = Enables interrupt from MON2 LO warning.

SFP+ Controller with Digital LDD Interface

Table 01h, Register FDh: WARN EN₂

POWER-ON VALUE	00h
READ ACCESS	PW2 or (PW1 and RWTBL1C) or (PW1 and RTBL1C)
WRITE ACCESS	PW2 or (PW1 and RWTBL1C)
MEMORY TYPE	Nonvolatile (SEE)

F9h	MON3 HI	MON3 LO	MON4 HI	MON4 LO	RESERVED	RESERVED	RESERVED	RESERVED
	BIT 7				BIT 0			

Layout is identical to WARN₂ in Lower Memory, Register 75h. Enables warnings to create TXFINT (Lower Memory, Register 71h) logic. The MASK bit (Table 02h, Register 89h) determines whether this memory exists in Table 01h or 05h.

BIT 7	MON3 HI: 0 = Disables interrupt from MON3 HI warning. 1 = Enables interrupt from MON3 HI warning.
BIT 6	MON3 LO: 0 = Disables interrupt from MON3 LO warning. 1 = Enables interrupt from MON3 LO warning.
BIT 5	MON4 HI: 0 = Disables interrupt from MON4 HI warning. 1 = Enables interrupt from MON4 HI warning.
BIT 4	MON4 LO: 0 = Disables interrupt from MON4 LO warning. 1 = Enables interrupt from MON4 LO warning.
BITS 3:0	RESERVED

Table 01h, Register FEh–FFh: RESERVED

POWER-ON VALUE	00h
READ ACCESS	N/A
WRITE ACCESS	N/A
MEMORY TYPE	Nonvolatile (SEE)

These registers are reserved.

SFP+ Controller with Digital LDD Interface

Table 02h Register Descriptions

Table 02h, Register 80h: MODE

POWER-ON VALUE	3Fh
READ ACCESS	PW2 or (PW1 and RWTBL246) or (PW1 and RTBL246)
WRITE ACCESS	PW2 or (PW1 and RTBL246)
MEMORY TYPE	Volatile

80h	SEEB	RESERVED	DAC1 EN	DAC2 EN	AEN	MOD EN	APC EN	BIAS EN
	BIT 7						BIT 0	

BIT 7	<p>SEEB: 0 = (Default) Enables EEPROM writes to SEE bytes. 1 = Disables EEPROM writes to SEE bytes during configuration, so that the configuration of the part is not delayed by the EE cycle time. Once the values are known, write this bit to a 0 and write the SEE locations again for data to be written to the EEPROM.</p>
BIT 6	<p>RESERVED</p>
BIT 5	<p>DAC1 EN: 0 = DAC1 VALUE is writable by the user and the LUT recalls are disabled. This allows users to interactively test their modules by writing the values for DAC1. The output is updated with the new value at the end of the write cycle. The I²C STOP condition is the end of the write cycle. 1 = (Default) Enables auto control of the LUT for DAC1 VALUE.</p>
BIT 4	<p>DAC2 EN: 0 = DAC2 VALUE is writable by the user and the LUT recalls are disabled. This allows users to interactively test their modules by writing the values for DAC2. The output is updated with the new value at the end of the write cycle. The I²C STOP condition is the end of the write cycle. 1 = (Default) Enables auto control of the LUT for DAC2 VALUE.</p>
BIT 3	<p>AEN: 0 = The temperature-calculated index value TINDEX is writable by users and the updates of calculated indexes are disabled. This allows users to interactively test their modules by controlling the indexing for the LUTs. The recalled values from the LUTs appear in the DAC registers after the next completion of a temperature conversion. 1 = (Default) The internal temperature sensor determines the value of TINDEX.</p>
BIT 2	<p>MOD EN: 0 = MODULATION register is writable by the user and the LUT recalls are disabled. This allows users to interactively test their modules by writing the DAC value for modulation. The output is updated with the new value at the end of the write cycle. The I²C STOP condition is the end of the write cycle. 1 = (Default) Enables auto control of the LUT for modulation.</p>
BIT 1	<p>APC EN: 0 = APC DAC is writable by the user and the LUT recalls are disabled. This allows users to interactively test their modules by writing the DAC value for APC reference. The output is updated with the new value at the end of the write cycle through the 3-wire interface. The I²C STOP condition is the end of the write cycle. 1 = (Default) Enables auto control of the LUT for APC reference.</p>
BIT 0	<p>BIAS EN: 0 = BIAS register is controlled by the user and the APC is in manual mode. The BIAS register value is written with the use of the 3-wire interface. This allows the user to interactively test their modules by writing the DAC value for bias. 1 = (Default) Enables auto control for the APC feedback.</p>

SFP+ Controller with Digital LDD Interface

Table 02h, Register 81h: TEMPERATURE INDEX (TINDEX)

FACTORY DEFAULT	00h
READ ACCESS	PW2 or (PW1 and RWTBL246) or (PW1 and RTBL246)
WRITE ACCESS	(PW2 and AEN = 0) or (PW1 and RWTBL246 and AEN = 0)
MEMORY TYPE	Volatile

81h	2 ⁷	2 ⁶	2 ⁵	2 ⁴	2 ³	2 ²	2 ¹	2 ⁰
	BIT 7							BIT 0

Holds the calculated index based on the temperature measurement. This index is used for the address during lookup of Tables 04h, 06h–08h. Temperature measurements below -40°C or above +102°C are clamped to 80h and C7h, respectively. The calculation of TINDEX is as follows:

$$\text{TINDEX} = \frac{\text{Temp_Value} + 40^{\circ}\text{C}}{2^{\circ}\text{C}} + 80\text{h}$$

For the temperature-indexed LUTs, the index used during the lookup function for each table is as follows:

Table 04h (MOD)	1	TINDEX ₆	TINDEX ₅	TINDEX ₄	TINDEX ₃	TINDEX ₂	TINDEX ₁	TINDEX ₀
Table 06h (APC)	1	0	TINDEX ₆	TINDEX ₅	TINDEX ₄	TINDEX ₃	TINDEX ₂	TINDEX ₁
Table 07h (DAC1)	1	0	TINDEX ₆	TINDEX ₅	TINDEX ₄	TINDEX ₃	TINDEX ₂	TINDEX ₁
Table 08h (DAC2)	1	0	TINDEX ₆	TINDEX ₅	TINDEX ₄	TINDEX ₃	TINDEX ₂	TINDEX ₁

Table 02h, Register 82h–83h: MODULATION REGISTER

FACTORY DEFAULT	0000h
READ ACCESS	PW2 or (PW1 and RWTBL246) or (PW1 and RTBL246)
WRITE ACCESS	(PW2 and MOD EN = 0) or (PW1 and RWTBL246 and MOD EN = 0)
MEMORY TYPE	Volatile

82h	0	0	0	0	0	0	0	2 ⁸
83h	2 ⁷	2 ⁶	2 ⁵	2 ⁴	2 ³	2 ²	2 ¹	2 ⁰
	BIT 7							BIT 0

The digital value used for MODULATION and recalled from Table 04h at the adjusted memory address found in TINDEX. This register is updated at the end of the temperature conversion.

SFP+ Controller with Digital LDD Interface

Table 02h, Register 84h–85h: DAC1 VALUE

FACTORY DEFAULT	0000h
READ ACCESS	PW2 or (PW1 and RWTBL246) or (PW1 and RTBL246)
WRITE ACCESS	(PW2 and DAC1 EN = 0) or (PW1 and RWTBL246 and DAC1 EN = 0)
MEMORY TYPE	Volatile

84h	0	0	0	0	0	0	0	2 ⁸
85h	2 ⁷	2 ⁶	2 ⁵	2 ⁴	2 ³	2 ²	2 ¹	2 ⁰
	BIT 7							BIT 0

The digital value used for DAC1 and recalled from Table 07h at the adjusted memory address found in TINDEX. This register is updated at the end of the temperature conversion.

$$V_{DAC1} = \frac{REFIN}{512} \times DAC1 \text{ VALUE}$$

Table 02h, Register 86h–87h: DAC2 VALUE

FACTORY DEFAULT	0000h
READ ACCESS	PW2 or (PW1 and RWTBL246) or (PW1 and RTBL246)
WRITE ACCESS	(PW2 and DAC2 EN = 0) or (PW1 and RWTBL246 and DAC2 EN = 0)
MEMORY TYPE	Volatile

86h	0	0	0	0	0	0	0	2 ⁸
87h	2 ⁷	2 ⁶	2 ⁵	2 ⁴	2 ³	2 ²	2 ¹	2 ⁰
	BIT 7							BIT 0

The digital value used for DAC2 and recalled from Table 08h at the adjusted memory address found in TINDEX. This register is updated at the end of the temperature conversion.

$$V_{DAC2} = \frac{REFIN}{512} \times DAC2 \text{ VALUE}$$

SFP+ Controller with Digital LDD Interface

Table 02h, Register 88h: SAMPLE RATE

FACTORY DEFAULT	00h
READ ACCESS	PW2 or (PW1 and RWTBL246) or (PW1 and RTBL246)
WRITE ACCESS	PW2 or (PW1 and RWTBL246)
MEMORY TYPE	Nonvolatile (SEE)

88h	SEE	SEE	SEE	SEE	SEE	APC_SR ₂	APC_SR ₁	APC_SR ₀
	BIT 7					BIT 0		

BITS 7:3	SEE	
BITS 2:0	APC_SR[2:0]: 3-bit sample rate for comparison of APC control. Defines the sample rate for comparison of APC control.	
	APC_SR[2:0]	SAMPLE PERIOD (t_{REP}) (ns)
	000b	800
	001b	1200
	010b	1600
	011b	2000
	100b	2800
	101b	3200
	110b	4400
111b	6400	

SFP+ Controller with Digital LDD Interface

Table 02h, Register 89h: CNFGA

FACTORY DEFAULT	80h
READ ACCESS	PW2 or (PW1 and RWTBL246) or (PW1 and RTBL246)
WRITE ACCESS	PW2 or (PW1 and RWTBL246)
MEMORY TYPE	Nonvolatile (SEE)

89h	LOSC	RESERVED	INV LOS	ASEL	MASK	INVR SOUT	RESERVED	INVTXF
	BIT 7							BIT 0

BIT 7	LOSC: LOS Configuration. Defines the source for the LOSOUT pin (see Figure 15). 0 = LOS LO alarm is used as the source. 1 = (Default) LOS input pin is used as the source.
BIT 6	RESERVED
BIT 5	INV LOS: Inverts the buffered input pin LOS or LOS LO alarm to output pin LOSOUT (see Figure 15). 0 = Noninverted LOS or LOS LO alarm to LOSOUT pin. 1 = Inverted LOS or LOS LO alarm to LOSOUT pin.
BIT 4	ASEL: Address Select. 0 = Device address is A2h. 1 = Byte DEVICE ADDRESS in Table 02h, Register 8Ch is used as the device address.
BIT 3	MASK: 0 = Alarm-enable row exists at Table 01h, Registers F8h–FFh. Table 05h, Registers F8h–FFh are empty. 1 = Alarm-enable row exists at Table 05h, Registers F8h–FFh. Table 01h, Registers F8h–FFh are empty.
BIT 2	INVR SOUT: Allow for inversion of RSELOUT pin (see Figure 15). 0 = RSELOUT is not inverted. 1 = RSELOUT is inverted.
BIT 1	RESERVED
BIT 0	INVTXF: Allow for inversion of signal driven by the TXF input pin. 0 = (Default) TXF signal is not inverted. 1 = TXF signal is inverted.

SFP+ Controller with Digital LDD Interface

Table 02h, Register 8Ah: CNFGB

FACTORY DEFAULT	00h
READ ACCESS	PW2 or (PW1 and RWTBL246) or (PW1 and RTBL246)
WRITE ACCESS	PW2 or (PW1 and RWTBL246)
MEMORY TYPE	Nonvolatile (SEE)

8Ah	RESERVED	RESERVED	RESERVED	RESERVED	RESERVED	ALATCH	QTLATCH	WLATCH
	BIT 7							BIT 0

BITS 7:3	RESERVED
BIT 2	ALATCH: ADC Alarm's Comparison Latch. Lower Memory, Registers 70h–71h. 0 = ADC alarm flags reflect the status of the last comparison. 1 = ADC alarm flags remain set.
BIT 1	QTLATCH: Quick Trip's Comparison Latch. Lower Memory, Registers 72h–73h. 0 = QT alarm flags reflect the status of the last comparison. 1 = QT alarm flags remain set.
BIT 0	WLATCH: ADC Warning's Comparison Latch. Lower Memory, Registers 74h–75h. 0 = ADC warning flags reflect the status of the last comparison. 1 = ADC warning flags remain set.

SFP+ Controller with Digital LDD Interface

Table 02h, Register 8Bh: CNFGC

FACTORY DEFAULT	00h
READ ACCESS	PW2 or (PW1 and RWTBL246) or (PW1 and RTBL246)
WRITE ACCESS	PW2 or (PW1 and RWTBL246)
MEMORY TYPE	Nonvolatile (SEE)

8Bh	XOVEREN	INVMON2	TXDM34	TXDFG	TXDFLT	TXDIO	RSSI_FC	RSSI_FF
	BIT 7						BIT 0	

BIT 7	XOVEREN: Enables RSSI conversion to use the XOVER (Table 02h, Register 90h–91h) value during MON3 conversions. 0 = Uses hysteresis for linear RSSI measurements. 1 = XOVER value is enabled for nonlinear RSSI measurements.
BIT 6	INVMON2: 0 = MON2 is referenced to GND. 1 = MON2 is referenced to V _{CC} .
BIT 5	TXDM34: Enables TXD to reset alarms and warnings associated to MON3 and MON4 during a TXD event. 0 = TXD event has no effect on the MON3 and MON4 alarms, warnings, and quick trips. 1 = MON3 and MON4 alarms, warnings, and quick trips are reset during a TXD event.
BIT 4	TXDFG: See Figure 14. 0 = FETG, an internal signal, has no effect on TXDOUT. 1 = FETG is enabled and ORed with other possible signals to create TXDOUT.
BIT 3	TXDFLT: See Figure 14. 0 = TXF pin has no effect on TXDOUT. 1 = TXF pin is enabled and ORed with other possible signals to create TXDOUT.
BIT 2	TXDIO: See Figure 14. 0 = (Default) TXD input signal is enabled and ORed with other possible signals to create TXDOUT. 1 = TXD input signal has no effect on TXDOUT.
BITS 1:0	RSSI_FC and RSSI_FF: RSSI Force Coarse and RSSI Force Fine. Control bits for RSSI mode of operation on the MON3 conversion. 00b = Normal RSSI mode of operation (default). 01b = The fine settings of scale and offset are used for MON3 conversions. 10b = The coarse settings of scale and offset are used for MON3 conversions. 11b = Normal RSSI mode of operation.

SFP+ Controller with Digital LDD Interface

Table 02h, Register 8Ch: DEVICE ADDRESS

FACTORY DEFAULT	00h
READ ACCESS	PW2 or (PW1 and RWTBL246) or (PW1 and RTBL246)
WRITE ACCESS	PW2 or (PW1 and RWTBL246)
MEMORY TYPE	Nonvolatile (SEE)

8Ch	2 ⁷	2 ⁶	2 ⁵	2 ⁴	2 ³	2 ²	2 ¹	2 ⁰
	BIT 7						BIT 0	

This value becomes the I²C slave address for the main memory when the ASEL (Table 02h, Register 89h) bit is set. If A0h is programmed to this register, the auxiliary memory is disabled.

Table 02h, Register 8Dh: RESERVED

FACTORY DEFAULT	00h
READ ACCESS	N/A
WRITE ACCESS	N/A
MEMORY TYPE	Nonvolatile (SEE)

This register is reserved.

Table 02h, Register 8Eh: RIGHT-SHIFT₁ (RSHIFT₁)

FACTORY DEFAULT	00h
READ ACCESS	PW2 or (PW1 and RWTBL246) or (PW1 and RTBL246)
WRITE ACCESS	PW2 or (PW1 and RWTBL246)
MEMORY TYPE	Nonvolatile (SEE)

8Eh	RESERVED	MON1 ₂	MON1 ₁	MON1 ₀	RESERVED	MON2 ₂	MON2 ₁	MON2 ₀
	BIT 7				BIT 0			

Allows for right-shifting the final answer of MON1 and MON2 voltage measurements. This allows for scaling the measurements to the smallest full-scale voltage and then right-shifting the final result so the reading is weighted to the correct LSB.

SFP+ Controller with Digital LDD Interface

Table 02h, Register 8Fh: RIGHT-SHIFT₀ (RSHIFT₀)

FACTORY DEFAULT	30h
READ ACCESS	PW2 or (PW1 and RWTBL246) or (PW1 and RTBL246)
WRITE ACCESS	PW2 or (PW1 and RWTBL246)
MEMORY TYPE	Nonvolatile (SEE)

8Fh	RESERVED	MON3C ₂	MON3C ₁	MON3C ₀	RESERVED	MON3F ₂	MON3F ₁	MON3F ₀
	BIT 7			BIT 0				

Allows for right-shifting the final answer of MON3 coarse (MON3C) and MON3 fine (MON3F) voltage measurements. This allows for scaling the measurements to the smallest full-scale voltage and then right-shifting the final result so the reading is weighted to the correct LSB.

Table 02h, Register 90h–91h: XOVER COARSE

FACTORY DEFAULT	0000h
READ ACCESS	PW2 or (PW1 and RWTBL2) or (PW1 and RTBL2)
WRITE ACCESS	PW2 or (PW1 and RWTBL2)
MEMORY TYPE	Nonvolatile (SEE)

90h	2 ¹⁵	2 ¹⁴	2 ¹³	2 ¹²	2 ¹¹	2 ¹⁰	2 ⁹	2 ⁸
91h	2 ⁷	2 ⁶	2 ⁵	2 ⁴	2 ³	2 ²	2 ¹	0
	BIT 7			BIT 0				

Defines the crossover value for RSSI measurements of nonlinear inputs when XOVEREN is set to 1 (Table 02h, Register 8Bh). MON3 coarse conversion results (before right-shifting) less than this register are clamped to the value of this register.

SFP+ Controller with Digital LDD Interface

Table 02h, Register 92h–93h: VCC SCALE
 Table 02h, Register 94h–95h: MON1 SCALE
 Table 02h, Register 96h–97h: MON2 SCALE
 Table 02h, Register 98h–99h: MON3 FINE SCALE
 Table 02h, Register 9Ah–9Bh: MON4 SCALE
 Table 02h, Register 9Ch–9Dh: MON3 COARSE SCALE

FACTORY CALIBRATED

READ ACCESS PW2 or (PW1 and RWTBL246) or (PW1 and RTBL246)

WRITE ACCESS PW2 or (PW1 and RWTBL246)

MEMORY TYPE Nonvolatile (SEE)

92h, 94h, 96h, 98h, 9Ah, 9Ch	2 ¹⁵	2 ¹⁴	2 ¹³	2 ¹²	2 ¹¹	2 ¹⁰	2 ⁹	2 ⁸	
93h, 95h, 97h, 99h, 9Bh, 9Dh	2 ⁷	2 ⁶	2 ⁵	2 ⁴	2 ³	2 ²	2 ¹	2 ⁰	
	BIT 7								BIT 0

Controls the scaling or gain of the FS voltage measurements. The factory-calibrated value produces an FS voltage of 6.5536V for V_{CC}; 2.5V for MON1, MON2, MON4; and 0.3125V for MON3 fine.

Table 02h, Register 9Eh–9Fh: RESERVED

FACTORY DEFAULT 00h

READ ACCESS PW2 or (PW1 and RWTBL246) or (PW1 and RTBL246)

WRITE ACCESS PW2 or (PW1 and RWTBL246)

MEMORY TYPE Nonvolatile (SEE)

These registers are reserved.

SFP+ Controller with Digital LDD Interface

Table 02h, Register A0h–A1h: XOVER FINE

FACTORY DEFAULT	FFFFh							
READ ACCESS	PW2 or (PW1 and RWTBL2) or (PW1 and RTBL2)							
WRITE ACCESS	PW2 or (PW1 and RWTBL2)							
MEMORY TYPE	Nonvolatile (SEE)							

A0h	2 ¹⁵	2 ¹⁴	2 ¹³	2 ¹²	2 ¹¹	2 ¹⁰	2 ⁹	2 ⁸
A1h	2 ⁷	2 ⁶	2 ⁵	2 ⁴	2 ³	2 ²	2 ¹	0

BIT 7 BIT 0

Defines the crossover value for RSSI measurements of nonlinear inputs when XOVEREN is set to 1 (Table 02h, Register 8Bh). MON3 fine conversion results (before right-shifting) greater than this register require a MON3 coarse conversion.

- Table 02h, Register A2h–A3h: VCC OFFSET**
Table 02h, Register A4h–A5h: MON1 OFFSET
Table 02h, Register A6h–A7h: MON2 OFFSET
Table 02h, Register A8h–A9h: MON3 FINE OFFSET
Table 02h, Register AAh–ABh: MON4 OFFSET
Table 02h, Register ACh–ADh: MON3 COARSE OFFSET

FACTORY DEFAULT	00h							
READ ACCESS	PW2 or (PW1 and RWTBL246) or (PW1 and RTBL246)							
WRITE ACCESS	PW2 or (PW1 and RWTBL246)							
MEMORY TYPE	Nonvolatile (SEE)							

A2h, A4h, A6h, A8h, AAh, ACh	S	S	2 ¹⁵	2 ¹⁴	2 ¹³	2 ¹²	2 ¹¹	2 ¹⁰
A3h, A5h, A7h, A9h, ABh, ADh	2 ⁹	2 ⁸	2 ⁷	2 ⁶	2 ⁵	2 ⁴	2 ³	2 ²

BIT 7 BIT 0

Allows for offset control of these voltage measurements if desired. This number is two's complement.

SFP+ Controller with Digital LDD Interface

Table 02h, Register AEh–AFh: INTERNAL TEMP OFFSET

FACTORY CALIBRATED

READ ACCESS PW2 or (PW1 and RWTBL246) or (PW1 and RTBL246)

WRITE ACCESS PW2 or (PW1 and RWTBL246)

MEMORY TYPE Nonvolatile (SEE)

AEh	S	2^8	2^7	2^6	2^5	2^4	2^3	2^2	
AFh	2^1	2^0	2^{-1}	2^{-2}	2^{-3}	2^{-4}	2^{-5}	2^{-6}	
	BIT 7								BIT 0

Allows for offset control of temperature measurement if desired. The final result must be XORed with BB40h before writing to this register. Factory calibration contains the desired value for a reading in degrees Celsius.

SFP+ Controller with Digital LDD Interface

Table 02h, Register B0h–B3h: PW1

FACTORY DEFAULT	FFFF FFFFh
READ ACCESS	N/A
WRITE ACCESS	PW2 or (PW1 and WPW1)
MEMORY TYPE	Nonvolatile (SEE)

B0h	2 ³¹	2 ³⁰	2 ²⁹	2 ²⁸	2 ²⁷	2 ²⁶	2 ²⁵	2 ²⁴
B1h	2 ²³	2 ²²	2 ²¹	2 ²⁰	2 ¹⁹	2 ¹⁸	2 ¹⁷	2 ¹⁶
B2h	2 ¹⁵	2 ¹⁴	2 ¹³	2 ¹²	2 ¹¹	2 ¹⁰	2 ⁹	2 ⁸
B3h	2 ⁷	2 ⁶	2 ⁵	2 ⁴	2 ³	2 ²	2 ¹	2 ⁰
	BIT 7				BIT 0			

The PWE value is compared against the value written to this location to enable PW1 access. At power-on, the PWE value is set to all ones. Thus, writing these bytes to all ones grants PW1 access on power-on without writing the password entry. All reads of this register are 00h.

Table 02h, Register B4h–B7h: PW2

FACTORY DEFAULT	FFFF FFFFh
READ ACCESS	N/A
WRITE ACCESS	PW2
MEMORY TYPE	Nonvolatile (SEE)

B4h	2 ³¹	2 ³⁰	2 ²⁹	2 ²⁸	2 ²⁷	2 ²⁶	2 ²⁵	2 ²⁴
B5h	2 ²³	2 ²²	2 ²¹	2 ²⁰	2 ¹⁹	2 ¹⁸	2 ¹⁷	2 ¹⁶
B6h	2 ¹⁵	2 ¹⁴	2 ¹³	2 ¹²	2 ¹¹	2 ¹⁰	2 ⁹	2 ⁸
B7h	2 ⁷	2 ⁶	2 ⁵	2 ⁴	2 ³	2 ²	2 ¹	2 ⁰
	BIT 7				BIT 0			

The PWE value is compared against the value written to this location to enable PW2 access. At power-on, the PWE value is set to all ones. Thus, writing these bytes to all ones grants PW2 access on power-on without writing the password entry. All reads of this register are 00h.

SFP+ Controller with Digital LDD Interface

Table 02h, Register B8h: LOS RANGING

FACTORY DEFAULT	00h
READ ACCESS	PW2 or (PW1 and RWTBL246) or (PW1 and RTBL246)
WRITE ACCESS	PW2 or (PW1 and RWTBL246)
MEMORY TYPE	Nonvolatile (SEE)

B8h	RESERVED	HLOS ₂	HLOS ₁	HLOS ₀	RESERVED	LLOS ₂	LLOS ₂₁	LLOS ₀
	BIT 7					BIT 0		

This register controls the full-scale range of the quick-trip monitoring for the differential inputs of MON3.

BIT 7	RESERVED (Default = 0)		
BITS 6:4	HLOS[2:0]: HLOS Full-Scale Ranging. 3-bit value to select the FS comparison voltage for high LOS found on MON3. Default is 000b and creates an FS of 1.25V.		
	HLOS[2:0]	% OF 1.25V	FS VOLTAGE (V)
	000b	100.00	1.250
	001b	80.00	1.000
	010b	66.67	0.833
	011b	50.00	0.625
	100b	40.00	0.500
	101b	33.33	0.417
	110b	28.57	0.357
111b	25.00	0.313	
BIT 3	RESERVED (Default = 0)		
BITS 2:0	LLOS[2:0]: LLOS Full-Scale Ranging. 3-bit value to select the FS comparison voltage for low LOS found on MON3. Default is 000b and creates an FS of 1.25V.		
	LLOS[2:0]	% OF 1.25V	FS VOLTAGE (V)
	000b	100.00	1.250
	001b	80.00	1.000
	010b	66.67	0.833
	011b	50.00	0.625
	100b	40.00	0.500
	101b	33.33	0.417
	110b	28.57	0.357
111b	25.00	0.313	

SFP+ Controller with Digital LDD Interface

Table 02h, Register B9h: COMP RANGING

FACTORY DEFAULT	00h
READ ACCESS	PW2
WRITE ACCESS	PW2
MEMORY TYPE	Nonvolatile (SEE)

B9h	RESERVED	BIAS ₂	BIAS ₁	BIAS ₀	RESERVED	APC ₂	APC ₁	APC ₀
	BIT 7				BIT 0			

The upper nibble of this byte controls the full-scale range of the quick-trip monitoring for BIAS. The lower nibble of this byte controls the full-scale range for the quick-trip monitoring of the APC reference as well as the closed-loop monitoring of APC.

BIT 7	RESERVED (Default = 0)		
BITS 6:4	BIAS[2:0]: BIAS Full-Scale Ranging. 3-bit value to select the FS comparison voltage for BIAS found on MON1. Default is 000b and creates an FS of 1.25V.		
	BIAS[2:0]	% OF 1.25V	FS VOLTAGE (V)
	000b	100.00	1.250
	001b	80.00	1.000
	010b	66.67	0.833
	011b	50.00	0.625
	100b	40.00	0.500
	101b	33.33	0.417
	110b	28.57	0.357
111b	25.00	0.313	
BIT 3	RESERVED (Default = 0)		
BITS 2:0	APC[2:0]: APC Full-Scale Ranging. 3-bit value to select the FS comparison voltage for MON2 with the APC. Default is 000b and creates an FS of 2.5V.		
	APC[2:0]	% OF 2.50V	FS VOLTAGE (V)
	000b	100.00	2.500
	001b	80.00	2.000
	010b	66.67	1.667
	011b	50.00	1.250
	100b	40.00	1.000
	101b	33.33	0.833
	110b	28.57	0.714
111b	25.00	0.625	

SFP+ Controller with Digital LDD Interface

Table 02h, Register BAh: ISTEPH

FACTORY DEFAULT	00h
READ ACCESS	PW2 or (PW1 and RWTBL246) or (PW1 and RTBL246)
WRITE ACCESS	PW2 or (PW1 and RWTBL246)
MEMORY TYPE	Nonvolatile (SEE)

BAh	2 ⁸	2 ⁷	2 ⁶	2 ⁵	2 ⁴	2 ³	2 ²	2 ¹
	BIT 7							BIT 0

ISTEP is the initial step value used at power-on or after a TXD pulse to control the BIAS register. The particular ISTEP used depends on the value of TINDEX and ISTEPTI (Table 02h, Register C5h). When TINDEX > ISTEPTI, ISTEPH is used. When TINDEX < ISTEPTI, ISTEPL is used. At startup, this value plus $2^0 = 1$ is continuously added to the BIAS register value until the APC feedback (MON2) is greater than its threshold. At that time, a binary search is used to complete the startup of the APC closed loop. If the resulting math operation is greater than IBIASMAX (Table 02h, Register EEh), the result is not loaded into the BIAS register, but the binary search is begun to complete the initial search for APC. During startup, the BIAS register steps causing a higher bias value than IBIASMAX do not create the BIAS MAX alarm. The BIAS MAX alarm detection is enabled at the end of the binary search.

Table 02h, Register BBh: ISTEPL

FACTORY DEFAULT	00h
READ ACCESS	PW2 or (PW1 and RWTBL246) or (PW1 and RTBL246)
WRITE ACCESS	PW2 or (PW1 and RWTBL246)
MEMORY TYPE	Nonvolatile (SEE)

BBh	2 ⁸	2 ⁷	2 ⁶	2 ⁵	2 ⁴	2 ³	2 ²	2 ¹
	BIT 7							BIT 0

See the ISTEPH register description.

SFP+ Controller with Digital LDD Interface

Table 02h, Register BCh: HTXP

FACTORY DEFAULT	00h
READ ACCESS	PW2 or (PW1 and RWTBL246) or (PW1 and RTBL246)
WRITE ACCESS	PW2 or (PW1 and RWTBL246)
MEMORY TYPE	Nonvolatile (SEE)

BCh	2 ⁷	2 ⁶	2 ⁵	2 ⁴	2 ³	2 ²	2 ¹	2 ⁰
	BIT 7							BIT 0

Fast-comparison DAC threshold adjust for high TXP. This value is added to the APC DAC value recalled from Table 06h. If the sum is greater than 0xFF, 0xFF is used. Comparisons greater than V_{HTXP} , compared against V_{MON2} , create a TXP HI alarm. The same ranging applied to the APC DAC should be used here.

$$V_{HTXP} = \frac{\text{Full Scale}}{255} \times (\text{HTXP} + \text{APC DAC})$$

Table 02h, Register BDh: LTXP

FACTORY DEFAULT	00h
READ ACCESS	PW2 or (PW1 and RWTBL246) or (PW1 and RTBL246)
WRITE ACCESS	PW2 or (PW1 and RWTBL246)
MEMORY TYPE	Nonvolatile (SEE)

BDh	2 ⁷	2 ⁶	2 ⁵	2 ⁴	2 ³	2 ²	2 ¹	2 ⁰
	BIT 7							BIT 0

Fast-comparison DAC threshold adjust for low TXP. This value is subtracted from the APC DAC value recalled from Table 06h. If the difference is less than 0x00, 0x00 is used. Comparisons less than V_{LTXP} , compared against V_{MON2} , create a TXP LO alarm. The same ranging applied to the APC DAC should be used here.

$$V_{LTXP} = \frac{\text{Full Scale}}{255} \times (\text{APC DAC} - \text{LTXP})$$

SFP+ Controller with Digital LDD Interface

Table 02h, Register BEh: HLOS

FACTORY DEFAULT	00h
READ ACCESS	PW2 or (PW1 and RWTBL246) or (PW1 and RTBL246)
WRITE ACCESS	PW2 or (PW1 and RWTBL246)
MEMORY TYPE	Nonvolatile (SEE)

BEh	2 ⁷	2 ⁶	2 ⁵	2 ⁴	2 ³	2 ²	2 ¹	2 ⁰
	BIT 7							BIT 0

Fast-comparison DAC threshold adjust for high LOS. The combination of HLOS and LLOS creates a hysteresis comparator. As RSSI falls below the LLOS threshold, the LOS LO alarm bit is set to 1. The LOS alarm remains set until the RSSI input is found above the HLOS threshold setting, which clears the LOS LO alarm bit and sets the LOS HI alarm bit. At power-on, both LOS LO and LOS HI alarm bits are 0 and the hysteresis comparator uses the LLOS threshold setting.

Table 02h, Register BFh: LLOS

FACTORY DEFAULT	00h
READ ACCESS	PW2 or (PW1 and RWTBL246) or (PW1 and RTBL246)
WRITE ACCESS	PW2 or (PW1 and RWTBL246)
MEMORY TYPE	Nonvolatile (SEE)

BFh	2 ⁷	2 ⁶	2 ⁵	2 ⁴	2 ³	2 ²	2 ¹	2 ⁰
	BIT 7							BIT 0

Fast-comparison DAC threshold adjust for low LOS. See HLOS (Table 02h, Register BEh) for functional description.

SFP+ Controller with Digital LDD Interface

Table 02h, Register C0h: PW_ENA

FACTORY DEFAULT	10h
READ ACCESS	PW2 or (PW1 and RWTBL246) or (PW1 and RTBL246)
WRITE ACCESS	PW2 or (PW1 and RWTBL246)
MEMORY TYPE	Nonvolatile (SEE)

C0h	RWTBL78	RWTBL1C	RWTBL2	RWTBL1A	RWTBL1B	WLOWER	WAUXA	WAUXB
	BIT 7						BIT 0	

BIT 7	RWTBL78: Tables 07h–08h 0 = (Default) Read and write access for PW2 only. 1 = Read and write access for both PW1 and PW2.
BIT 6	RWTBL1C: Table 01h or 05h bytes F8h–FFh. Table address is dependent on MASK bit (Table 02h, Register 89h). 0 = (Default) Read and write access for PW2 only. 1 = Read and write access for both PW1 and PW2.
BIT 5	RWTBL2: Tables 02h, except for PW1 value locations (Table 02h, Registers B0h–B3h). 0 = (Default) Read and write access for PW2 only. 1 = Read and write access for both PW1 and PW2.
BIT 4	RWTBL1A: Read and Write Table 01h, Registers 80h–BFh 0 = Read and write access for PW2 only. 1 = (Default) Read and write access for both PW1 and PW2.
BIT 3	RWTBL1B: Read and Write Table 01h, Registers C0h–F7h 0 = (Default) Read and write access for PW2 only. 1 = Read and write access for both PW1 and PW2.
BIT 2	WLOWER: Write Lower Memory Bytes 00h–5Fh in main memory. All users can read this area. 0 = (Default) Write access for PW2 only. 1 = Write access for both PW1 and PW2.
BIT 1	WAUXA: Write Auxiliary Memory, Registers 00h–7Fh. All users can read this area. Also see Table 02h, Register C1h, PW_ENB. 0 = (Default) Write access for PW2 only. 1 = Write access for both PW1 and PW2.
BIT 0	WAUXB: Write Auxiliary Memory, Registers 80h–FFh. All users can read this area. Also see Table 02h, Register C1h, PW_ENB. 0 = (Default) Write access for PW2 only. 1 = Write access for both PW1 and PW2.

SFP+ Controller with Digital LDD Interface

Table 02h, Register C1h: PW_ENB

FACTORY DEFAULT	03h
READ ACCESS	PW2 or (PW1 and RWTBL246) or (PW1 and RTBL246)
WRITE ACCESS	PW2 or (PW1 and RWTBL246)
MEMORY TYPE	Nonvolatile (SEE)

C1h	RWTBL46	RTBL1C	RTBL2	RTBL1A	RTBL1B	WPW1	WAUXAU	WAUXBU
	BIT 7						BIT 0	

BIT 7	RWTBL46: Read and Write Tables 04h, 06h 0 = (Default) Read and write access for PW2 only. 1 = Read and write access for both PW1 and PW2.
BIT 6	RTBL1C: Read Table 01h or Table 05h, Registers F8h–FFh. Table address is dependent on MASK bit (Table 02h, Register 89h). 0 = (Default) Read access for PW2 only. 1 = Read access for PW1 and PW2.
BIT 5	RTBL2: Read Table 02h except for PW1 value locations (Table 02h, Registers B0h–B3h) 0 = (Default) Read access for PW2 only. 1 = Read access for PW1 and PW2.
BIT 4	RTBL1A: Read Table 01h, Registers 80h–BFh 0 = (Default) Read access for PW2 only. 1 = Read access for PW1 and PW2.
BIT 3	RTBL1B: Read Table 01h, Registers C0h–F7h 0 = (Default) Read access for PW2 only. 1 = Read access for PW1 and PW2.
BIT 2	WPW1: Write Register PW1 (Table 02h, Registers B0h–B3h). For security purposes these registers are not readable. 0 = (Default) Write access for PW2 only. 1 = Write access for PW1 and PW2.
BIT 1	WAUXAU: Write Auxiliary Memory, Registers 00h–7Fh. All users can read this area. Also see Table 02h, Register C0h, PW_ENA. 0 = Write access for PW2 only. 1 = (Default) Write access for user, PW1 and PW2.
BIT 0	WAUXBU: Write Auxiliary Memory, Registers 80h–FFh. All users can read this area. Also see Table 02h, Register C0h, PW_ENA. 0 = Read and write access for PW2 only. 1 = (Default) Read and write access for user, PW1 and PW2.

SFP+ Controller with Digital LDD Interface

Table 02h, Register C2h: MODTI

FACTORY DEFAULT	00h
READ ACCESS	PW2 or (PW1 and RWTBL246) or (PW1 and RTBL246)
WRITE ACCESS	PW2 or (PW1 and RWTBL246)
MEMORY TYPE	Nonvolatile (SEE)

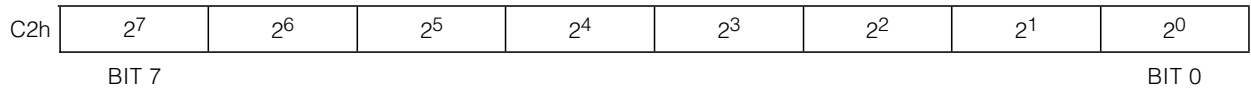

The modulation temperature index defines the TempCo boundary for the MODULATION LUT. The MODTC bit (Table 02h, Register C6h) defines the polarity of the TempCo.

$$\text{MODTI} = \frac{\text{Temp_Value} + 40^{\circ}\text{C}}{2^{\circ}\text{C}} + 80\text{h}$$

Table 02h, Register C3h: DAC1TI

FACTORY DEFAULT	00h
READ ACCESS	PW2 or (PW1 and RWTBL246) or (PW1 and RTBL246)
WRITE ACCESS	PW2 or (PW1 and RWTBL246)
MEMORY TYPE	Nonvolatile (SEE)

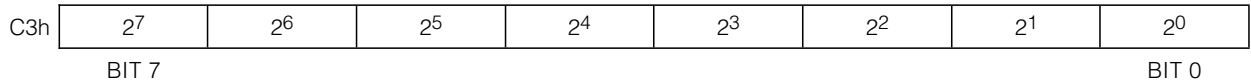

DAC1 temperature index (DAC1TI) defines the TempCo boundary for the DAC1 LUT. The DAC1TC bit (Table 02h, Register C6h) defines the polarity of the TempCo. This value is compared with the adjusted memory address used during the LUT recall, not the value in the TINDEX register (Table 02h, Register 81h).

$$\text{DAC1TI} = \frac{\text{Temp_Value} + 40^{\circ}\text{C}}{4^{\circ}\text{C}} + 80\text{h}$$

SFP+ Controller with Digital LDD Interface

Table 02h, Register C4h: DAC2TI

FACTORY DEFAULT	00h
READ ACCESS	PW2 or (PW1 and RWTBL246) or (PW1 and RTBL246)
WRITE ACCESS	PW2 or (PW1 and RWTBL246)
MEMORY TYPE	Nonvolatile (SEE)

C4h	2 ⁷	2 ⁶	2 ⁵	2 ⁴	2 ³	2 ²	2 ¹	2 ⁰
	BIT 7							BIT 0

DAC2 temperature index defines the TempCo boundary for the DAC2 LUT. The DAC2TC bit (Table 02h, Register C6h) defines the polarity of the TempCo. This value is compared with the adjusted memory address used during the LUT recall, not the value in the TINDEXT register (Table 02h, Register 81h).

$$\text{DAC2TI} = \frac{\text{Temp_Value} + 40^{\circ}\text{C}}{4^{\circ}\text{C}} + 80\text{h}$$

Table 02h, Register C5h: ISTEPTI

FACTORY DEFAULT	00h
READ ACCESS	PW2 or (PW1 and RWTBL246) or (PW1 and RTBL246)
WRITE ACCESS	PW2 or (PW1 and RWTBL246)
MEMORY TYPE	Nonvolatile (SEE)

Determines which value between ISTEPH and ISTEPL is used as the ISTEP. TINDEXT > ISTEPTI, ISTEPH is used. TINDEXT < ISTEPTI, ISTEPL is used.

SFP+ Controller with Digital LDD Interface

Table 02h, Register C6h: LUTTC

FACTORY DEFAULT	00h
READ ACCESS	PW2 or (PW1 and RWTBL246) or (PW1 and RTBL246)
WRITE ACCESS	PW2 or (PW1 and RWTBL246)
MEMORY TYPE	Nonvolatile (SEE)

C6h	MODTC	DAC1TC	DAC2TC	RESERVED	RESERVED	RESERVED	RESERVED	RESERVED
	BIT 7							BIT 0

BIT 7	<p>MODTC: Modulation TempCo 0 = Positive TempCo. For a TINDEX (Table 02h, Register 81h) below the MODTI value (Table 02h, Register C2h), the 8-bit recalled value from the MODULATION LUT is stored in the lower 8 bits of the MODULATION register. For a TINDEX greater than or equal to MODTI, the recalled value is stored in the upper 8 bits of the MODULATION register. 1 = Negative TempCo. For a TINDEX below the MODTI value, the 8-bit recalled value from the MODULATION LUT is stored in the upper 8 bits of the MODULATION register. For a TINDEX greater than or equal to MODTI, the recalled value is stored in the lower 8 bits of the MODULATION register.</p>
BIT 6	<p>DAC1TC: DAC1 TempCo 0 = Positive TempCo. For a TINDEX (Table 02h, Register 81h) below the DAC1TI value (Table 02h, Register C3h), the 8-bit recalled value from the DAC1 LUT is stored in the lower 8 bits of the DAC1 DAC's register. For a TINDEX greater than or equal to DAC1TI, the recalled value is stored in the upper 8 bits of the DAC1 DAC's register. 1 = Negative TempCo. For a TINDEX below the DAC1TI value, the 8-bit recalled value from the DAC1 LUT is stored in the upper 8 bits of the DAC1 DAC's register. For a TINDEX greater than or equal to DAC1TI, the recalled value is stored in the lower 8 bits of the DAC1 DAC's register.</p>
BIT 5	<p>DAC2TC: DAC2 TempCo 0 = Positive TempCo. For a TINDEX (Table 02h, Register 81h) below the DAC2TI value (Table 02h, Register C4h), the 8-bit recalled value from the DAC2 LUT is stored in the lower 8 bits of the DAC2 DAC's register. For a TINDEX greater than or equal to DAC2TI, the recalled value is stored in the upper 8 bits of the DAC2 DAC's register. 1 = Negative TempCo. For a TINDEX below the DAC2TI value, the 8-bit recalled value from the DAC2 LUT is stored in the upper 8 bits of the DAC2 DAC's register. For a TINDEX greater than or equal to DAC2TI, the recalled value is stored in the lower 8 bits of the DAC2 DAC's register.</p>
BITS 4:0	RESERVED

SFP+ Controller with Digital LDD Interface

Table 02h, Register C7h: TBLSELPON

FACTORY DEFAULT	00h
READ ACCESS	PW2 or (PW1 and RWTBL246) or (PW1 and RTBL246)
WRITE ACCESS	PW2 or (PW1 and RWTBL246)
MEMORY TYPE	Nonvolatile (SEE)

C7h	2 ⁷	2 ⁶	2 ⁵	2 ⁴	2 ³	2 ²	2 ¹	2 ⁰
	BIT 7							BIT 0

Chooses the initial value for the table-select byte (Lower Memory, Register 7Fh) at power-on.

Table 02h, Register C8h–C9h: MAN BIAS

FACTORY DEFAULT	0000h
READ ACCESS	PW2 or (PW1 and RWTBL246) or (PW1 and RTBL246)
WRITE ACCESS	(PW2 and BIAS EN = 0) or (PW1 and RWTBL246 and BIAS EN = 0)
MEMORY TYPE	Volatile

C8h	0	0	0	0	0	0	0	2 ⁸
C9h	2 ⁷	2 ⁶	2 ⁵	2 ⁴	2 ³	2 ²	2 ¹	2 ⁰
	BIT 7							BIT 0

When BIAS EN (Table 02h, Register 80h) is written to 0, writes to these bytes control the BIAS register, which then updates a Maxim laser driver SET_IBIAS register.

Table 02h, Register CAh: MAN_CNTL

FACTORY DEFAULT	00h
READ ACCESS	PW2 or (PW1 and RWTBL246) or (PW1 and RTBL246)
WRITE ACCESS	(PW2 and BIAS EN = 0) or (PW1 and RWTBL246 and BIAS EN = 0)
MEMORY TYPE	Volatile

CAh	RESERVED	RESERVED	RESERVED	RESERVED	RESERVED	RESERVED	RESERVED	MAN_CLK
	BIT 7							BIT 0

When BIAS EN (Table 02h, Register 80h) is written to 0, MAN_CLK controls the updates of the MAN BIAS value to the BIAS register. This new value is sent through the 3-wire interface. The values of MAN BIAS must be written with a separate write command. Setting MAN_CLK to a 1 clocks the MAN BIAS value to the BIAS register, which then updates a Maxim laser driver SET_IBIAS register.

- 1) Write the MAN BIAS value with a write command.
- 2) Set the MAN_CLK bit to a 1 with a separate write command.
- 3) Clear the MAN_CLK bit to a 0 with a separate write command.

SFP+ Controller with Digital LDD Interface

Table 02h, Register CBh–CCh: BIAS REGISTER

FACTORY DEFAULT	0000h
READ ACCESS	PW2 or (PW1 and RWTBL246) or (PW1 and RTBL246)
WRITE ACCESS	N/A
MEMORY TYPE	Volatile

CBh	RESERVED	RESERVED	RESERVED	RESERVED	RESERVED	RESERVED	RESERVED	2 ⁸
CCh	2 ⁷	2 ⁶	2 ⁵	2 ⁴	2 ³	2 ²	2 ¹	2 ⁰
	BIT 7							BIT 0

The digital value used for BIAS and resolved from the APC. This register is updated after each decision of the APC loop.

Table 02h, Register CDh: APC DAC

FACTORY DEFAULT	00h
READ ACCESS	PW2 or (PW1 and RWTBL246) or (PW1 and RTBL246)
WRITE ACCESS	(PW2 and APC EN = 0) or (PW1 and RWTBL246 and APC EN = 0)
MEMORY TYPE	Volatile

CDh	2 ⁷	2 ⁶	2 ⁵	2 ⁴	2 ³	2 ²	2 ¹	2 ⁰
	BIT 7							BIT 0

The digital value used for APC reference and recalled from Table 06h at the adjusted memory address found in TINDEX. This register is updated at the end of the temperature conversion.

Table 02h, Register CEh: DEVICE ID

FACTORY DEFAULT	78h
READ ACCESS	PW2 or (PW1 and RWTBL246) or (PW1 and RTBL246)
WRITE ACCESS	N/A
MEMORY TYPE	ROM

CEh	0	1	1	1	1	0	0	0
	BIT 7							BIT 0

Hardwired connections to show the device ID.

SFP+ Controller with Digital LDD Interface

Table 02h, Register CFh: DEVICE VER

FACTORY DEFAULT	DEVICE VERSION
READ ACCESS	PW2 or (PW1 and RWTBL246) or (PW1 and RTBL246)
WRITE ACCESS	N/A
MEMORY TYPE	ROM



Hardwired connections to show the device version.

Table 02h, Register D0h–D7h: HBATH

FACTORY DEFAULT	00h
READ ACCESS	PW2 or (PW1 and RWTBL246) or (PW1 and RTBL246)
WRITE ACCESS	PW2 or (PW1 and RWTBL246)
MEMORY TYPE	Nonvolatile (SEE)

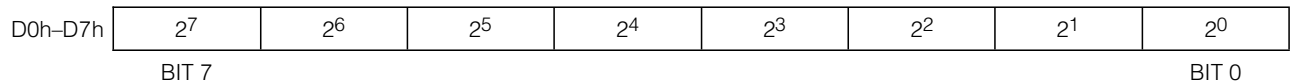

High-Bias Alarm Threshold (HBATH) is a digital clamp used to ensure that the DAC setting for BIAS currents does not exceed a set value. The table below shows the range of temperature for each byte's location. The table shows a rising temperature; for a falling temperature there is 1°C of hysteresis.

D0h	Less than or equal to -8°C
D1h	Greater than -8°C up to +8°C
D2h	Greater than +8°C up to +24°C
D3h	Greater than +24°C up to +40°C
D4h	Greater than +40°C up to +56°C
D5h	Greater than +56°C up to +72°C
D6h	Greater than +72°C up to +88°C
D7h	Greater than +88°C

SFP+ Controller with Digital LDD Interface

Table 02h, Register D8h–E7h: EMPTY

FACTORY DEFAULT	00h
READ ACCESS	N/A
WRITE ACCESS	N/A
MEMORY TYPE	None

These registers do not exist.

Table 02h, Register E8h: RXCTRL1

FACTORY DEFAULT	00h
READ ACCESS	PW2 or (PW1 and RWTBL246) or (PW1 and RTBL246)
WRITE ACCESS	PW2 or (PW1 and RWTBL246)
MEMORY TYPE	Nonvolatile (SEE)

E8h	2 ⁷	2 ⁶	2 ⁵	2 ⁴	2 ³	2 ²	2 ¹	2 ⁰
	BIT 7							BIT 0

A 3-wire slave register. After either V_{CC} exceeds POA (after a POR event), the Maxim laser driver TX_POR bit is set high (visible in 3W TXSTAT1, Bit 7), or on a rising edge of TXD, this value is written to a Maxim laser driver through the 3-wire interface.

Table 02h, Register E9h: RXCTRL2

FACTORY DEFAULT	00h
READ ACCESS	PW2 or (PW1 and RWTBL246) or (PW1 and RTBL246)
WRITE ACCESS	PW2 or (PW1 and RWTBL246)
MEMORY TYPE	Nonvolatile (SEE)

E9h	2 ⁷	2 ⁶	2 ⁵	2 ⁴	2 ³	2 ²	2 ¹	2 ⁰
	BIT 7							BIT 0

A 3-wire slave register. After either V_{CC} exceeds POA (after a POR event), the Maxim laser driver TX_POR bit is set high (visible in 3W TXSTAT1, Bit 7), or on a rising edge of TXD, this value is written to a Maxim laser driver through the 3-wire interface.

SFP+ Controller with Digital LDD Interface

Table 02h, Register EAh: SETCML

FACTORY DEFAULT	00h
READ ACCESS	PW2 or (PW1 and RWTBL246) or (PW1 and RTBL246)
WRITE ACCESS	PW2 or (PW1 and RWTBL246)
MEMORY TYPE	Nonvolatile (SEE)

EAh	2 ⁷	2 ⁶	2 ⁵	2 ⁴	2 ³	2 ²	2 ¹	2 ⁰
	BIT 7							BIT 0

A 3-wire slave register. After either V_{CC} exceeds POA (after a POR event), the Maxim laser driver TX_POR bit is set high (visible in 3W TXSTAT1, Bit 7), or on a rising edge of TXD, this value is written to a Maxim laser driver through the 3-wire interface.

Table 02h, Register EBh: SETLOSH

FACTORY DEFAULT	00h
READ ACCESS	PW2 or (PW1 and RWTBL246) or (PW1 and RTBL246)
WRITE ACCESS	PW2 or (PW1 and RWTBL246)
MEMORY TYPE	Nonvolatile (SEE)

EBh	2 ⁷	2 ⁶	2 ⁵	2 ⁴	2 ³	2 ²	2 ¹	2 ⁰
	BIT 7							BIT 0

A 3-wire slave register. Only written if SETLOSCTL is 1. If SETLOSCTL is 0, the SETLOSL register is used. After either V_{CC} exceeds POA (after a POR event), the Maxim laser driver TX_POR bit is set high (visible in 3W TXSTAT1, Bit 7), or on a rising edge of TXD, this value is written to a Maxim laser driver through the 3-wire interface.

Table 02h, Register ECh: TXCTRL

FACTORY DEFAULT	00h
READ ACCESS	PW2 or (PW1 and RWTBL246) or (PW1 and RTBL246)
WRITE ACCESS	PW2 or (PW1 and RWTBL246)
MEMORY TYPE	Nonvolatile (SEE)

ECh	2 ⁷	2 ⁶	2 ⁵	2 ⁴	2 ³	2 ²	2 ¹	2 ⁰
	BIT 7							BIT 0

A 3-wire slave register. After either V_{CC} exceeds POA (after a POR event), the Maxim laser driver TX_POR bit is set high (visible in 3W TXSTAT1, Bit 7), or on a rising edge of TXD, this value is written to a Maxim laser driver through the 3-wire interface.

SFP+ Controller with Digital LDD Interface

Table 02h, Register EDh: IMODMAX

FACTORY DEFAULT	00h
READ ACCESS	PW2 or (PW1 and RWTBL246) or (PW1 and RTBL246)
WRITE ACCESS	PW2 or (PW1 and RWTBL246)
MEMORY TYPE	Nonvolatile (SEE)

EDh	2 ⁷	2 ⁶	2 ⁵	2 ⁴	2 ³	2 ²	2 ¹	2 ⁰
	BIT 7							BIT 0

A 3-wire slave register. After either V_{CC} exceeds POA (after a POR event), the Maxim laser driver TX_POR bit is set high (visible in 3W TXSTAT1, Bit 7), or on a rising edge of TXD, this value is written to a Maxim laser driver through the 3-wire interface.

Table 02h, Register EEh: IBIASMAX

FACTORY DEFAULT	00h
READ ACCESS	PW2 or (PW1 and RWTBL246) or (PW1 and RTBL246)
WRITE ACCESS	PW2 or (PW1 and RWTBL246)
MEMORY TYPE	Nonvolatile (SEE)

EEh	2 ⁷	2 ⁶	2 ⁵	2 ⁴	2 ³	2 ²	2 ¹	2 ⁰
	BIT 7							BIT 0

A 3-wire slave register. After either V_{CC} exceeds POA (after a POR event), the Maxim laser driver TX_POR bit is set high (visible in 3W TXSTAT1, Bit 7) or on a rising edge of TXD, this value is written to a Maxim laser driver through the 3-wire interface. In addition, this value defines the maximum DAC value allowed for the upper 8 bits of BIAS output during APC closed-loop operations. During the initial step and binary search, this value does not cause an alarm but still clamps the BIAS register value. After the startup sequence (or normal APC operations), if the APC loop tries to create a BIAS value greater than this setting, it is clamped and creates a MAX BIAS alarm.

SFP+ Controller with Digital LDD Interface

Table 02h, Register EFh: SETPWCTRL

FACTORY DEFAULT	00h
READ ACCESS	PW2 or (PW1 and RWTBL246) or (PW1 and RTBL246)
WRITE ACCESS	PW2 or (PW1 and RWTBL246)
MEMORY TYPE	Nonvolatile (SEE)

EFh	2 ⁷	2 ⁶	2 ⁵	2 ⁴	2 ³	2 ²	2 ¹	2 ⁰
	BIT 7							BIT 0

A 3-wire slave register. After either V_{CC} exceeds POA (after a POR event), the Maxim laser driver TX_POR bit is set high (visible in 3W TXSTAT1, Bit 7), or on a rising edge of TXD, this value is written to a Maxim laser driver through the 3-wire interface.

Table 02h, Register F0h: SETTXDE

FACTORY DEFAULT	00h
READ ACCESS	PW2 or (PW1 and RWTBL246) or (PW1 and RTBL246)
WRITE ACCESS	PW2 or (PW1 and RWTBL246)
MEMORY TYPE	Nonvolatile (SEE)

F0h	2 ⁷	2 ⁶	2 ⁵	2 ⁴	2 ³	2 ²	2 ¹	2 ⁰
	BIT 7							BIT 0

A 3-wire slave register. After either V_{CC} exceeds POA (after a POR event), the Maxim laser driver TX_POR bit is set high (visible in 3W TXSTAT1, Bit 7), or on a rising edge of TXD, this value is written to a Maxim laser driver through the 3-wire interface.

SFP+ Controller with Digital LDD Interface

Table 02h, Register F1h: SETTXEQ

FACTORY DEFAULT	00h
READ ACCESS	PW2 or (PW1 and RWTBL246) or (PW1 and RTBL246)
WRITE ACCESS	PW2 or (PW1 and RWTBL246)
MEMORY TYPE	Nonvolatile (SEE)

F1h	2 ⁷	2 ⁶	2 ⁵	2 ⁴	2 ³	2 ²	2 ¹	2 ⁰
	BIT 7							BIT 0

A 3-wire slave register. The writing of this register is enabled using EXCTRL[1:0]. After either V_{CC} exceeds POA (after a POR event), the Maxim laser driver TX_POR bit is set high (visible in 3W TXSTAT1, Bit 7), or on a rising edge of TXD, this value is written to a Maxim laser driver through the 3-wire interface.

Table 02h, Register F2h: SETLOSTIMER

FACTORY DEFAULT	00h
READ ACCESS	PW2 or (PW1 and RWTBL246) or (PW1 and RTBL246)
WRITE ACCESS	PW2 or (PW1 and RWTBL246)
MEMORY TYPE	Nonvolatile (SEE)

F2h	2 ⁷	2 ⁶	2 ⁵	2 ⁴	2 ³	2 ²	2 ¹	2 ⁰
	BIT 7							BIT 0

A 3-wire slave register. The writing of this register is enabled using EXCTRL[1:0]. After either V_{CC} exceeds POA (after a POR event), the Maxim laser driver TX_POR bit is set high (visible in 3W TXSTAT1, Bit 7), or on a rising edge of TXD, this value is written to a Maxim laser driver through the 3-wire interface.

SFP+ Controller with Digital LDD Interface

Table 02h, Register F3h: SETLOSL

FACTORY DEFAULT	00h
READ ACCESS	PW2 or (PW1 and RWTBL246) or (PW1 and RTBL246)
WRITE ACCESS	PW2 or (PW1 and RWTBL246)
MEMORY TYPE	Nonvolatile (SEE)

F3h	2 ⁷	2 ⁶	2 ⁵	2 ⁴	2 ³	2 ²	2 ¹	2 ⁰
	BIT 7							BIT 0

A 3-wire slave register. Only written if SETLOSCTL is 0. If SETLOSCTL is 1, then SETLOSH register is used. After either V_{CC} exceeds POA (after a POR event), the Maxim laser driver TX_POR bit is set high (visible in 3W TXSTAT1, Bit 7), or on a rising edge of TXD, this value is written to a Maxim laser driver through the 3-wire interface.

Table 02h, Register F4h: RXCTRL3

FACTORY DEFAULT	00h
READ ACCESS	PW2 or (PW1 and RWTBL246) or (PW1 and RTBL246)
WRITE ACCESS	PW2 or (PW1 and RWTBL246)
MEMORY TYPE	Nonvolatile (SEE)

F4h	2 ⁷	2 ⁶	2 ⁵	2 ⁴	2 ³	2 ²	2 ¹	2 ⁰
	BIT 7							BIT 0

A 3-wire slave register. The writing of this register is enabled using EXCTRL[1:0]. After either V_{CC} exceeds POA (after a POR event), the Maxim laser driver TX_POR bit is set high (visible in 3W TXSTAT1, Bit 7), or on a rising edge of TXD, this value is written to a Maxim laser driver through the 3-wire interface.

SFP+ Controller with Digital LDD Interface

Table 02h, Register F5h: TXCTRL2

FACTORY DEFAULT	00h
READ ACCESS	PW2 or (PW1 and RWTBL246) or (PW1 and RTBL246)
WRITE ACCESS	PW2 or (PW1 and RWTBL246)
MEMORY TYPE	Nonvolatile (SEE)

F5h	2 ⁷	2 ⁶	2 ⁵	2 ⁴	2 ³	2 ²	2 ¹	2 ⁰
	BIT 7							BIT 0

A 3-wire slave register. The writing of this register is enabled using EXCTRL[1:0]. After either V_{CC} exceeds POA (after a POR event), the Maxim laser driver TX_POR bit is set high (visible in 3W TXSTAT1, Bit 7), or on a rising edge of TXD, this value is written to a Maxim laser driver through the 3-wire interface.

Table 02h, Register F6h: TXCTRL3

FACTORY DEFAULT	00h
READ ACCESS	PW2 or (PW1 and RWTBL246) or (PW1 and RTBL246)
WRITE ACCESS	PW2 or (PW1 and RWTBL246)
MEMORY TYPE	Nonvolatile (SEE)

F6h	2 ⁷	2 ⁶	2 ⁵	2 ⁴	2 ³	2 ²	2 ¹	2 ⁰
	BIT 7							BIT 0

A 3-wire slave register. The writing of this register is enabled using EXCTRL[1:0]. After either V_{CC} exceeds POA (after a POR event), the Maxim laser driver TX_POR bit is set high (visible in 3W TXSTAT1, Bit 7), or on a rising edge of TXD, this value is written to a Maxim laser driver through the 3-wire interface.

SFP+ Controller with Digital LDD Interface

Table 02h, Register F7h: 3WSET

FACTORY DEFAULT	00h
READ ACCESS	PW2 or (PW1 and RWTBL246) or (PW1 and RTBL246)
WRITE ACCESS	PW2 or (PW1 and RWTBL246)
MEMORY TYPE	Nonvolatile (SEE)

F7h	RESERVED	RESERVED	RESERVED	RESERVED	RESERVED	TXPORDIS	EXCTRL1	EXCTRL2
	BIT 7						BIT 0	

BITS 7:3	RESERVED
BIT 2	TXPORDIS: Transmit POR Disable. 0 = The 3-wire interface monitors the TXPOR bit in the laser driver's TXSTAT1 register. 1 = The 3-wire interface ignores the TXPOR bit in the laser driver's TXSTAT1 register.
BITS 1:0	EXCTRL[1:0]: Extra 3-Wire Control Register Selection. Used to enable/disable the 3-wire registers. 00 = SETTSEQ and SETLOSTIMER are enabled. 01 = Device mode. SETTSEQ, SETLOSTIMER, RXCTRL3, TXCTRL2, and TXCTRL3 are disabled. 10 = SETTSEQ, SETLOSTIMER, and RXCTRL3 are enabled. 11 = SETTSEQ, SETLOSTIMER, RXCTRL3, TXCTRL2, and TXCTRL3 are enabled.

Table 02h, Register F8h: 3WCTRL

FACTORY DEFAULT	00h
READ ACCESS	PW2 or (PW1 and RWTBL246) or (PW1 and RTBL246)
WRITE ACCESS	PW2 or (PW1 and RWTBL246)
MEMORY TYPE	Volatile

F8h	RESERVED	RESERVED	RESERVED	RESERVED	RESERVED	RESERVED	3WRW	3WDIS
	BIT 7						BIT 0	

BITS 7:2	RESERVED
BIT 1	3WRW: Initiates a 3-wire write or read operation. The write command uses the memory address found in the 3-wire ADDRESS register (Table 02h, Register F9h) and the data from the 3-wire WRITE register (Table 02h, Register FAh). This bit clears itself at the completion of the write operation. The read command uses the memory address found in the 3-wire ADDRESS register (Table 02h, Register F9h). The address determines whether a read or write operation is to be performed. This bit clears itself at the completion of the read operation. 0 = (Default) Reads back as 0 when the write or read operation is completed. 1 = Initiates a 3-wire write or read operation.
BIT 0	3WDIS: Disables all automatic communication across the 3-wire interface. This includes all updates from the LUTs, APC loop, and status registers. The only 3-wire communication is with the manual mode of operation. 0 = (Default) Automatic communication is enabled. 1 = Disables automatic communication.

SFP+ Controller with Digital LDD Interface

Table 02h, Register F9h: ADDRESS

FACTORY DEFAULT	00h
READ ACCESS	PW2 or (PW1 and RWTBL246) or (PW1 and RTBL246)
WRITE ACCESS	PW2 or (PW1 and RWTBL246)
MEMORY TYPE	Nonvolatile (SEE)

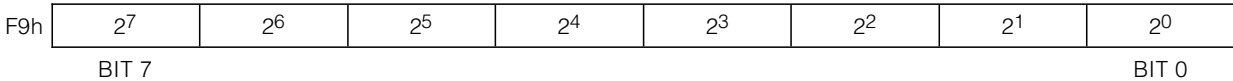

This byte is used during manual 3-wire communication. When a manual read or write is initiated, this register contains the address for the operation.

Table 02h, Register FAh: WRITE

FACTORY DEFAULT	00h
READ ACCESS	PW2 or (PW1 and RWTBL246) or (PW1 and RTBL246)
WRITE ACCESS	PW2 or (PW1 and RWTBL246)
MEMORY TYPE	Nonvolatile (SEE)

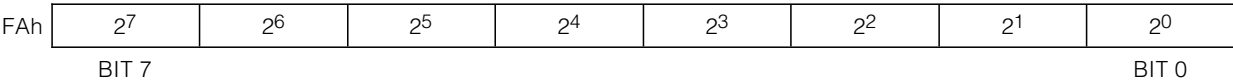

This byte is used during manual 3-wire communication. When a manual write is initiated, this register contains the data for the operation.

SFP+ Controller with Digital LDD Interface

Table 02h, Register FBh: READ

FACTORY DEFAULT	00h
READ ACCESS	PW2 or (PW1 and RWTBL246) or (PW1 and RTBL246)
WRITE ACCESS	N/A
MEMORY TYPE	Volatile

FBh	2 ⁷	2 ⁶	2 ⁵	2 ⁴	2 ³	2 ²	2 ¹	2 ⁰
	BIT 7							BIT 0

This byte is used during manual 3-wire communication. When a manual read is initiated, the return data is stored in this register.

Table 02h, Register FCh: TXSTAT1

FACTORY DEFAULT	00h
READ ACCESS	PW2 or (PW1 and RWTBL246) or (PW1 and RTBL246)
WRITE ACCESS	N/A
MEMORY TYPE	Nonvolatile (SEE)

FCh	2 ⁷	2 ⁶	2 ⁵	2 ⁴	2 ³	2 ²	2 ¹	2 ⁰
	BIT 7							BIT 0

A 3-wire slave register. This value is read from the Maxim laser driver with the 3-wire interface every t_{RR} (see the Maxim laser driver's electrical characteristics).

Table 02h, Register FDh: TXSTAT2

FACTORY DEFAULT	00h
READ ACCESS	PW2 or (PW1 and RWTBL246) or (PW1 and RTBL246)
WRITE ACCESS	N/A
MEMORY TYPE	Nonvolatile (SEE)

FDh	2 ⁷	2 ⁶	2 ⁵	2 ⁴	2 ³	2 ²	2 ¹	2 ⁰
	BIT 7							BIT 0

A 3-wire slave register. This value is read from the Maxim laser driver with the 3-wire interface every t_{RR} (see the Maxim laser driver's electrical characteristics).

SFP+ Controller with Digital LDD Interface

Table 02h, Register FEh–FFh: RESERVED

FACTORY DEFAULT	00h
READ ACCESS	N/A
WRITE ACCESS	N/A
MEMORY TYPE	Nonvolatile (SEE)

These registers are reserved.

Table 04h Register Description

Table 04h, Register 80h–C7h: MODULATION LUT

FACTORY DEFAULT	00h
READ ACCESS	PW2 or (PW1 and RWTBL246) or (PW1 and RTBL246)
WRITE ACCESS	PW2 or (PW1 and RWTBL246)
MEMORY TYPE	Nonvolatile (EE)

80h–C7h	2 ⁷	2 ⁶	2 ⁵	2 ⁴	2 ³	2 ²	2 ¹	2 ⁰
	BIT 7							BIT 0

The digital value for the modulation DAC output. The MODULATION LUT is a set of registers assigned to hold the temperature profile for the MODULATION register. The temperature measurement is used to index the LUT (TINDEX, Table 02h, Register 81h) in 2°C increments from -40°C to +102°C, starting at 80h. Register 80h defines the -40°C to -38°C MOD output, Register 81h defines the -38°C to -36°C MOD output, and so on. Values recalled from this EEPROM memory table are written into the MODULATION register (Table 02h, Register 82h–83h) location that holds the value until the next temperature conversion. The device can be placed into a manual mode (MOD EN bit, Table 02h, Register 80h), where the MODULATION register is directly controlled for calibration. If the temperature compensation functionality is not required, then program the entire Table 04h to the desired modulation setting. The MODTC bit determines whether the 8-bit LUT values are loaded into the upper 8 bits or lower 8 bits of the 9-bit MOD DAC. See the *BIAS and MODULATION Control During Power-Up* section for more information.

SFP+ Controller with Digital LDD Interface

Table 06h Register Descriptions

Table 06h, Register 80h–A3h: APC LUT

FACTORY DEFAULT	00h
READ ACCESS	PW2 or (PW1 and RWTBL246) or (PW1 and RTBL246)
WRITE ACCESS	PW2 or (PW1 and RWTBL246)
MEMORY TYPE	Nonvolatile (EE)

80h–A3h	2 ⁷	2 ⁶	2 ⁵	2 ⁴	2 ³	2 ²	2 ¹	2 ⁰
	BIT 7							BIT 0

The APC LUT is a set of registers assigned to hold the temperature profile for the APC reference DAC. The values in this table combined with the APC bits in the COMP RANGING register (Table 02h, Register B9h) determine the set point for the APC loop. The temperature measurement is used to index the LUT (TINDEX, Table 02h, Register 81h) in 4°C increments from -40°C to +100°C, starting at Register 80h. Register 80h defines the -40°C to -36°C APC reference value, Register 81h defines the -36°C to -32°C APC reference value, and so on. Values recalled from this EEPROM memory table are written into the APC DAC (Table 02h, Register CDh) location that holds the value until the next temperature conversion. The device can be placed into a manual mode (APC EN bit, Table 02h, Register 80h), where the APC DAC can be directly controlled for calibration. If TE temperature compensation is not required by the application, program the entire LUT to the desired APC set point.

Table 06h, Register A4h–A7h: RESERVED

FACTORY DEFAULT	00h
READ ACCESS	N/A
WRITE ACCESS	N/A
MEMORY TYPE	Nonvolatile (EE)

These registers are reserved.

SFP+ Controller with Digital LDD Interface

Table 07h Register Descriptions

Table 07h, Register 80h–A3h: DAC1 LUT

FACTORY DEFAULT	00h
READ ACCESS	PW2 or (PW1 and RWTBL78) and (PW1 and RTBL78)
WRITE ACCESS	PW2 or (PW1 and RWTBL78)
MEMORY TYPE	Nonvolatile (EE)

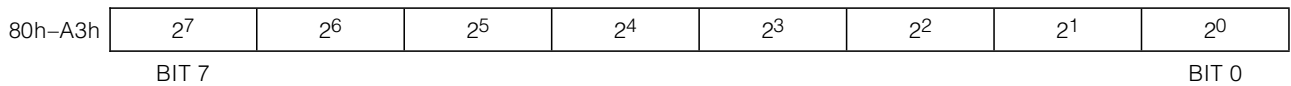

The DAC1 LUT is a set of registers assigned to hold the PWM profile for DAC1. The values in this table determine the set point for DAC1. The temperature measurement is used to index the LUT (TINDEX, Table 02h, Register 81h) in 4°C increments from -40°C to +100°C, starting at Register 80h. Register 80h defines the -40°C to -36°C DAC1 value, Register 81h defines -36°C to -32°C DAC1 value, and so on. Values recalled from this EEPROM memory table are written into the DAC1 VALUE (Table 02h, Registers 84h–85h) location, which holds the value until the next temperature conversion. The part can be placed into a manual mode (DAC1 EN bit, Table 02h, Register 80h), where DAC1 can be directly controlled for calibration. If temperature compensation is not required by the application, program the entire LUT to the desired DAC1 set point. The DAC1TC bit determines whether the 8-bit LUT values are loaded into the upper 8 bits or lower 8 bits of the 9-bit DAC1. See the *Delta-Sigma Outputs (DAC1 and DAC2)* section for more information.

Table 07h, Register A4h–A7h: RESERVED

FACTORY DEFAULT	00h
READ ACCESS	PW2 or (PW1 and RWTBL78) or (PW1 and RTBL78)
WRITE ACCESS	PW2 or (PW1 and RWTBL78)
MEMORY TYPE	Nonvolatile (EE)

These registers are reserved.

SFP+ Controller with Digital LDD Interface

Table 08h Register Descriptions

Table 08h, Register 80h–A3h: DAC2 LUT

FACTORY DEFAULT	00h
READ ACCESS	PW2 or (PW1 and RWTBL78) or (PW1 and RTBL78)
WRITE ACCESS	PW2 or (PW1 and RWTBL78)
MEMORY TYPE	Nonvolatile (EE)

80h–A3h	2^7	2^6	2^5	2^4	2^3	2^2	2^1	2^0
	BIT 7				BIT 0			

The DAC2 LUT is set of registers assigned to hold the PWM profile for DAC2. The values in this table determine the set point for DAC2. The temperature measurement is used to index the LUT (TINDEX, Table 02h, Register 81h) in 4°C increments from -40°C to +100°C, starting at Register 80h. Register 80h defines the -40°C to -36°C DAC2 value, Register 81h defines -36°C to -32°C DAC2 value, and so on. Values recalled from this EEPROM memory table are written into the DAC2 VALUE (Table 02h, Registers 86h–87h) location that holds the value until the next temperature conversion. The device can be placed into a manual mode (DAC2 EN bit, Table 02h, Register 80h), where DAC2 can be directly controlled for calibration. If temperature compensation is not required by the application, program the entire LUT to the desired DAC2 set point. The DAC2TC bit determines whether the 8-bit LUT values are loaded into the upper 8 bits or lower 8 bits of the 9-bit DAC2. See the *Delta-Sigma Outputs (DAC1 and DAC2)* section for more information.

Table 08h, Register A4h–A7h: RESERVED

FACTORY DEFAULT	00h
READ ACCESS	N/A
WRITE ACCESS	N/A
MEMORY TYPE	Nonvolatile (EE)

These registers are reserved.

SFP+ Controller with Digital LDD Interface

DS1878

Auxiliary Memory A0h Register Description

Auxiliary Memory A0h, Register 00h–FFh: EEPROM

FACTORY DEFAULT	00h
READ ACCESS	PW2 or (PW1 and WAUXA) or (PW1 and WAUXAU)
WRITE ACCESS	PW2 or (PW1 and WAUXA)
MEMORY TYPE	Nonvolatile (EE)

00h–FFh	2 ⁷	2 ⁶	2 ⁵	2 ⁴	2 ³	2 ²	2 ¹	2 ⁰
	BIT 7							BIT 0

Accessible with the slave address A0h.

Applications Information

Power-Supply Decoupling

To achieve best results, it is recommended that the power supply is decoupled with a 0.01 μ F or a 0.1 μ F capacitor. Use high-quality, ceramic, surface-mount capacitors, and mount the capacitors as close as possible to the V_{CC} and GND pins to minimize lead inductance.

SDA and SCL Pullup Resistors

SDA is an open-collector output on the device that requires a pullup resistor to realize high logic levels. A master using either an open-collector output with a pullup resistor or a push-pull output driver can be utilized for SCL. Pullup resistor values should be chosen to ensure that the rise and fall times listed in the *I²C AC Electrical Characteristics* table are within specification.

Package Information

For the latest package outline information and land patterns, go to www.maxim-ic.com/packages. Note that a "+", "#", or "-" in the package code indicates RoHS status only. Package drawings may show a different suffix character, but the drawing pertains to the package regardless of RoHS status.

PACKAGE TYPE	PACKAGE CODE	OUTLINE NO.	LAND PATTERN NO.
28 TQFN-EP	T2855+6	21-0140	90-0026

SFP+ Controller with Digital LDD Interface

Revision History

REVISION NUMBER	REVISION DATE	DESCRIPTION	PAGES CHANGED
0	9/10	Initial release	—

Maxim cannot assume responsibility for use of any circuitry other than circuitry entirely embodied in a Maxim product. No circuit patent licenses are implied. Maxim reserves the right to change the circuitry and specifications without notice at any time.

98 _____ **Maxim Integrated Products, 120 San Gabriel Drive, Sunnyvale, CA 94086 408-737-7600**

© 2010 Maxim Integrated Products

Maxim is a registered trademark of Maxim Integrated Products, Inc.