

# SGM8061 SGM8062 SGM8063

## 500MHz, Rail-to-Rail Output CMOS Operational Amplifier

### PRODUCT DESCRIPTION

The SGM8061, SGM8062, SGM8063 are rail-to-rail output voltage feedback amplifiers offering ease of use and low cost. They have bandwidth and slew rate typically found in current feedback amplifiers. All have a wide input common-mode voltage range and output voltage swing, making them easy to use on single supplies as low as 2.5 V.

Despite being low cost, the SGM8061 series provide excellent overall performance. they offer wide bandwidth to 500 MHz ( $G=+1$ ) along with 0.1 dB flatness out to 130 MHz ( $G=+1$ ) and offer a typical low power of 8.2 mA/amplifier.

The SGM8061 series is low distortion and fast settling make it ideal for buffering high speed A/D or D/A converters. The SGM8063 has a power-down disable feature that reduces the supply current to 75 $\mu$ A. These features make the SGM8063 ideal for portable and battery-powered applications where size and power are critical. All are specified over the extended  $-40^{\circ}\text{C}$  to  $+125^{\circ}\text{C}$  temperature range.

### FEATURES

- Low Cost
- Rail-to-Rail Output  
2mV Typical  $V_{OS}$
- High Speed  
500 MHz,  $-3$  dB Bandwidth ( $G=+1$ )  
420 V/ $\mu$ s, Slew Rate  
16 ns Settling Time to 0.1% with 2V Step
- Operates on 2.5 V to 5.5V Supplies
- Input Voltage Range =  $-0.2$  V to  $+3.8$  V with  $V_s = 5$  V
- Excellent Video Specs ( $R_L = 150\Omega$ ,  $G = +2$ )  
Gain Flatness 0.1dB to 80 MHz  
Diff Gain: 0.015 %, Diff Phase: 0.05 degree
- Low Power  
8.2 mA/Amplifier Typical Supply Current  
SGM8063 75 $\mu$ A when Disabled
- Small Packaging  
SGM8061 Available in SO-8 and SOT23-5  
SGM8062 Available in SO-8  
SGM8063 Available in SO-8 and SOT23-6

### PIN CONFIGURATIONS (Top View)

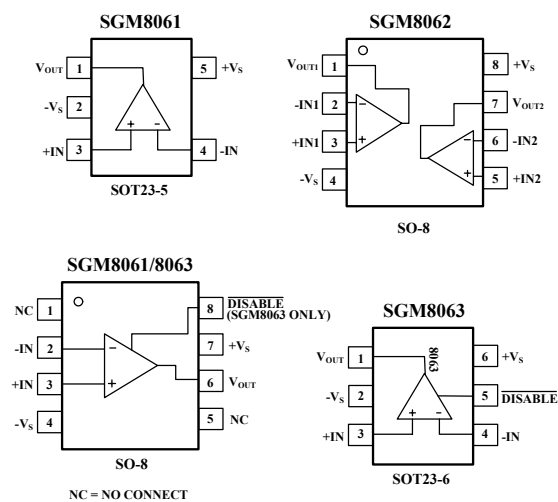

### APPLICATIONS

- Imaging
- Photodiode Preamp
- Professional Video and Cameras
- Hand Sets
- DVD/CD
- Base Stations
- Filters
- A-to-D Driver

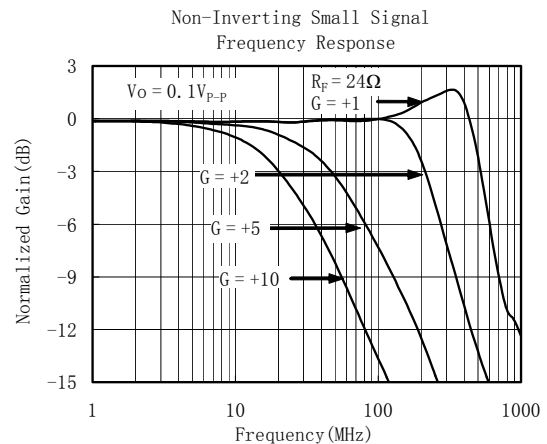

SG Micro Limited  
www.sg-micro.com

REV. A

# ELECTRICAL CHARACTERISTICS : $V_S = +5V$

( $G=+2$ ,  $R_F = 402\Omega$ ,  $R_L = 150\Omega$ , unless otherwise noted)

PARAMETER	CONDITION	SGM8061/2/3							
		TYP	MIN/MAX OVER TEMPERATURE					UNITS	MIN/ MAX
			+25°C	+25°C	0°C to 70°C	-40°C to 85°C	-40°C to 125°C		
<b>DYNAMIC PERFORMANCE</b>									
-3dB Small Signal Bandwidth	$G = +1$ , $V_o = 0.1 V$ p-p, $R_F = 24\Omega$	500						MHz	TYP
	$G = +1$ , $V_o = 0.1 V$ p-p, $R_F = 24\Omega$ , $R_L = 1K\Omega$	550						MHz	TYP
	$G = +2$ , $V_o = 0.1 V$ p-p, $R_L = 50\Omega$	130						MHz	TYP
	$G = +2$ , $V_o = 0.1 V$ p-p, $R_L = 150\Omega$	210						MHz	TYP
	$G = +2$ , $V_o = 0.1 V$ p-p, $R_L = 1k\Omega$	250						MHz	TYP
	$G = +2$ , $V_o = 0.1 V$ p-p, $R_L = 10k\Omega$	420						MHz	TYP
Gain-Bandwidth Product	$G = +10$ , $R_L = 150\Omega$	200						MHz	TYP
	$G = +10$ , $R_L = 1K\Omega$	230						MHz	TYP
Bandwidth for 0.1dB Flatness	$G = +1$ , $V_o = 0.1 V$ p-p, $R_F = 24\Omega$	130						MHz	TYP
	$G = +2$ , $V_o = 0.1 V$ p-p, $R_F = 330\Omega$	80						MHz	TYP
Slew Rate	$G = +1$ , 2V Output Step	320/-370						V/ $\mu$ S	TYP
	$G = +2$ , 2V Output Step	350/-320						V/ $\mu$ S	TYP
	$G = +2$ , 4V Output Step	420/-390						V/ $\mu$ S	TYP
Rise-and-Fall Time	$G = +2$ , $V_o = 0.2 V$ p-p, 10% to 90%	4						ns	TYP
	$G = +2$ , $V_o = 2 V$ p-p, 10% to 90%	4.5						ns	TYP
Settling Time to 0.1%	$G = +2$ , 2 V Output Step	16						ns	TYP
Overload Recovery Time	$V_{IN} \cdot G = +V_S$	6.2						ns	TYP
<b>NOISE/DISTORTION PERFORMANCE</b>									
Harmonic Distortion									
2nd-Harmonic	$G = +2$ , $f = 1MHz$ , $V_o = 2V$ p-p, $R_L = 150\Omega$							dBc	TYP
3rd-Harmonic	$G = +2$ , $f = 1MHz$ , $V_o = 2V$ p-p, $R_L = 150\Omega$							dBc	TYP
Input Voltage Noise	$f = 1MHz$	5.6						$nV/\sqrt{Hz}$	TYP
Input Current Noise	$f = 1MHz$							$fA/\sqrt{Hz}$	TYP
Differential Gain Error (NTSC)	$G = +2$ , $R_L = 150\Omega$	0.015						%	TYP
Differential Phase Error (NTSC)	$G = +2$ , $R_L = 150\Omega$	0.05						degree	TYP
<b>DC PERFORMANCE</b>									
Input Offset Voltage ( $V_{OS}$ )		$\pm 2$	$\pm 8$	$\pm 8.5$	$\pm 9$	$\pm 9.3$		mV	MAX
Input Offset Voltage Drift		3						$\mu V/^\circ C$	TYP
Input Bias Current ( $I_B$ )		6						pA	TYP
Input offset Current ( $I_{OS}$ )		2						pA	TYP
Open-Loop Gain ( $A_{OL}$ )	$V_o = 0.3 V$ to $4.7 V$ , $R_L = 150\Omega$	80	75	75	74	70		dB	MIN
	$V_o = 0.2 V$ to $4.8 V$ , $R_L = 1K\Omega$	104	90	90	89	80		dB	MIN
<b>INPUT CHARACTERISTICS</b>									
Input Common-Mode Voltage Range ( $V_{CM}$ )		-0.2 to +3.8						V	TYP
Common-Mode Rejection Ratio(CMRR)	$V_{CM} = -0.1 V$ to $+3.5 V$	80	66	65	64	62		dB	MIN
<b>OUTPUT CHARACTERISTICS</b>									
Output Voltage Swing from Rail	$R_L = 150\Omega$	0.12						V	TYP
	$R_L = 1K\Omega$	0.03						V	TYP
Output Current		120	100	98	93	87		mA	MIN
Closed-Loop Output Impedance	$f < 100kHz$	0.015						$\Omega$	TYP
<b>POWER-DOWN DISABLE</b>									
Turn-On Time		50						ns	TYP
Turn-Off Time		44						ns	TYP
<i>DISABLE</i> Voltage-Off			0.8					V	MAX
<i>DISABLE</i> Voltage-On			2					V	MIN
<b>POWER SUPPLY</b>									
Operating Voltage Range			2.5	2.7	2.7	2.7		V	MIN
			5.5	5.5	5.5	5.5		V	MAX
Quiescent Current (per amplifier)		8.2	10	10.3	10.5	11		mA	MAX
Supply Current when Disabled (SGM8063 only)		75	120	127	130	139		$\mu A$	MAX
Power Supply Rejection Ratio (PSRR)	$\Delta V_S = +2.7V$ to $+5.5V$ , $V_{CM} = (-V_S) + 0.5$	80	66	66	65	63		dB	MIN

Specifications subject to change without notice.

## PACKAGE/ORDERING INFORMATION

MODEL	ORDER NUMBER	PACKAGE DESCRIPTION	PACKAGE OPTION	MARKING INFORMATION
SGM8061	SGM8061XN5/TR	SOT23-5	Tape and Reel, 3000	8061
	SGM8061XS/TR	SO-8	Tape and Reel, 2500	SGM8061XS
SGM8062	SGM8062XS/TR	SO-8	Tape and Reel, 2500	SGM8062XS
SGM8063	SGM8063XN6/TR	SOT23-6	Tape and Reel, 3000	8063
	SGM8063XS/TR	SO-8	Tape and Reel, 2500	SGM8063XS

### ABSOLUTE MAXIMUM RATINGS

Supply Voltage, V+ to V- ..... 7.5 V  
 Common-Mode Input Voltage  
 ..... (-Vs) - 0.5 V to (+Vs) +0.5V  
 Storage Temperature Range ..... -65°C to +150°C  
 Junction Temperature ..... 160°C  
 Operating Temperature Range ..... -55°C to +150°C  
 Package Thermal Resistance @ T<sub>A</sub> = 25°C  
 SOT23-5, θ<sub>JA</sub>..... 190°C/W  
 SOT23-6, θ<sub>JA</sub>..... 190°C/W  
 SO-8, θ<sub>JA</sub>..... 125°C/W  
 Lead Temperature Range (Soldering 10 sec)  
 ..... 260°C  
 ESD Susceptibility  
 HBM.....1000V  
 MM.....400V

### NOTES

1. Stresses above those listed under Absolute Maximum Ratings may cause permanent damage to the device. This is a stress rating only; functional operation of the device at these or any other conditions above those indicated in the operational section of this specification is not implied. Exposure to absolute maximum rating conditions for extended periods may affect device reliability.

### CAUTION

This integrated circuit can be damaged by ESD. SGMICRO recommends that all integrated circuits be handled with appropriate precautions. Failure to observe proper handling and installation procedures can cause damage.  
 ESD damage can range from subtle performance degradation to complete device failure. Precision integrated circuits may be more susceptible to damage because very small parametric changes could cause the device not to meet its published specifications.

# TYPICAL PERFORMANCE CHARACTERISTICS

At  $T_A = +25^\circ\text{C}$ ,  $V_S = +5\text{V}$ ,  $G = +2$ ,  $R_F = 402\Omega$ ,  $R_G = 402\Omega$ , and  $R_L = 150\Omega$  connected to  $V_S/2$ , unless otherwise noted.

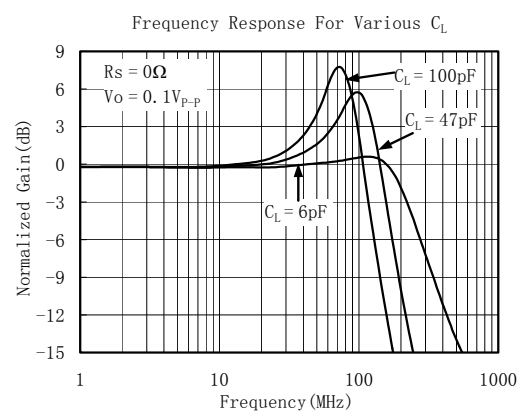
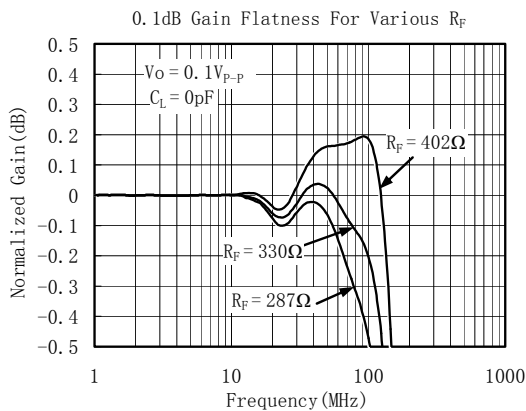
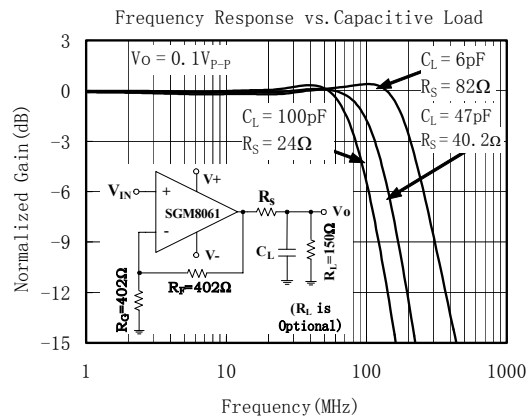
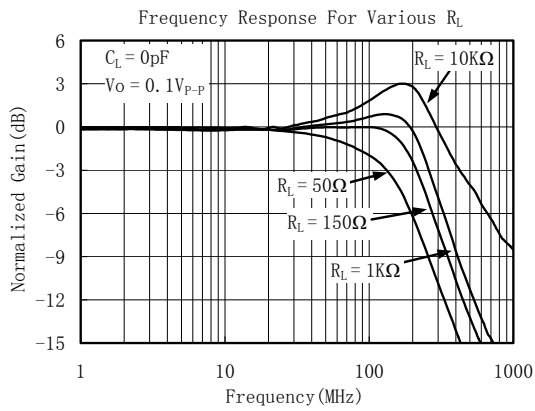
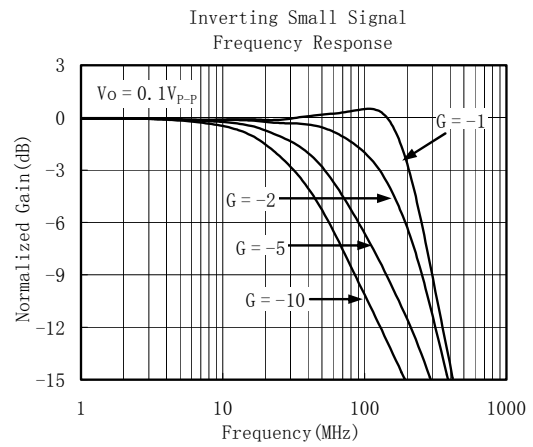
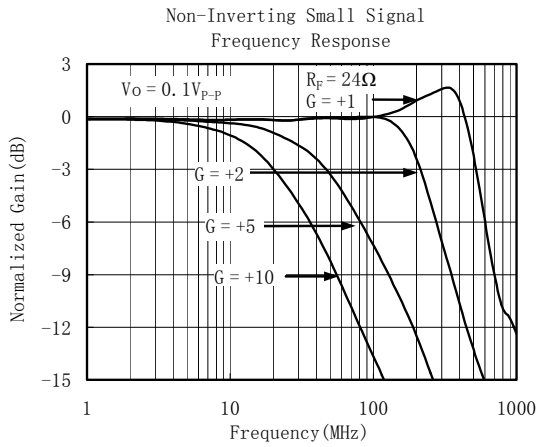

# TYPICAL PERFORMANCE CHARACTERISTICS

At  $T_A = +25^\circ\text{C}$ ,  $V_S = +5\text{V}$ ,  $G = +2$ ,  $R_F = 402\Omega$ ,  $R_G = 402\Omega$ , and  $R_L = 150\Omega$  connected to  $V_S/2$ , unless otherwise noted.

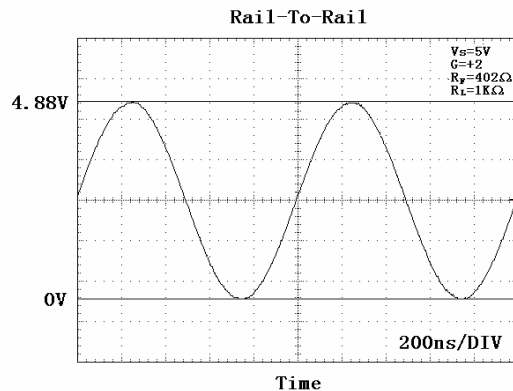
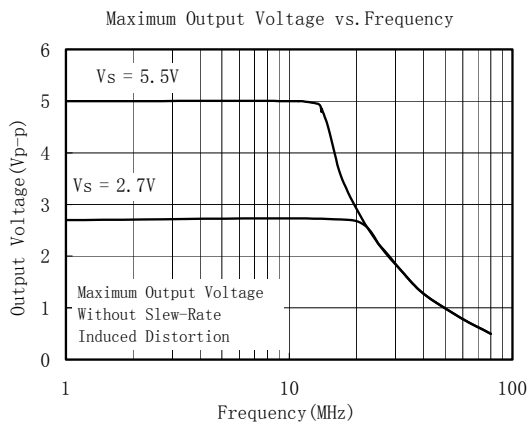
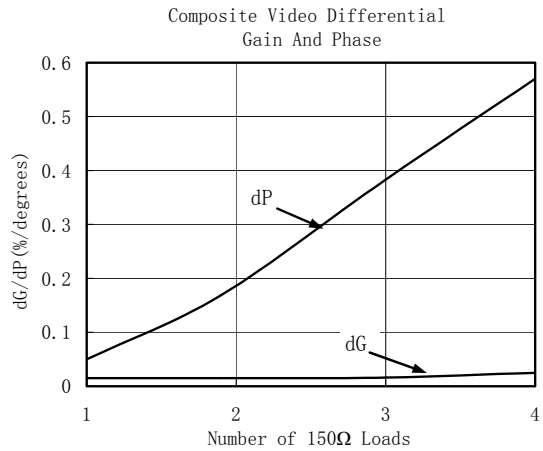
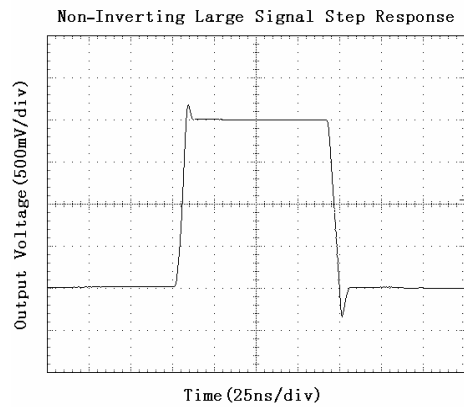
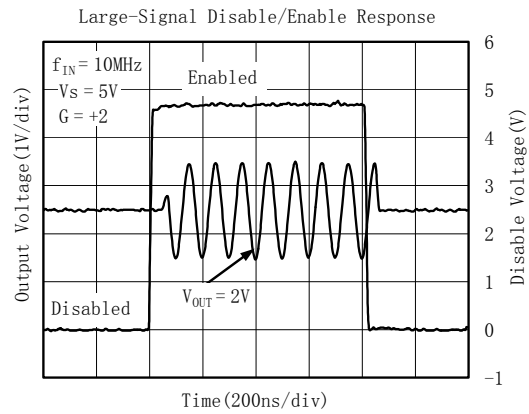
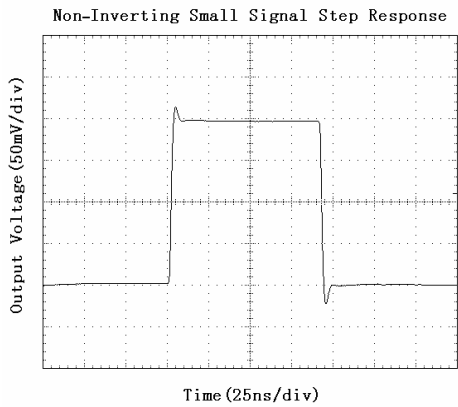

# TYPICAL PERFORMANCE CHARACTERISTICS

At  $T_A = +25^\circ\text{C}$ ,  $V_S = +5\text{V}$ ,  $G = +2$ ,  $R_F = 402\Omega$ ,  $R_G = 402\Omega$ , and  $R_L = 150\Omega$  connected to  $V_S/2$ , unless otherwise noted.

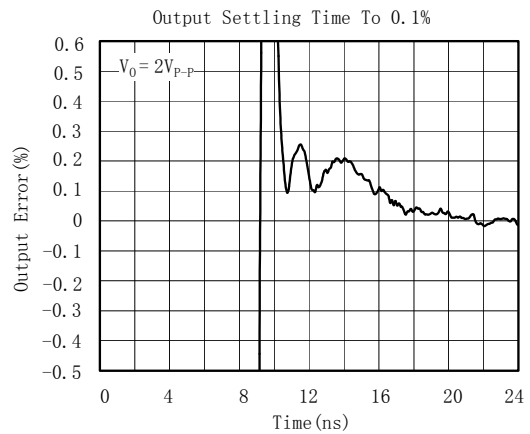
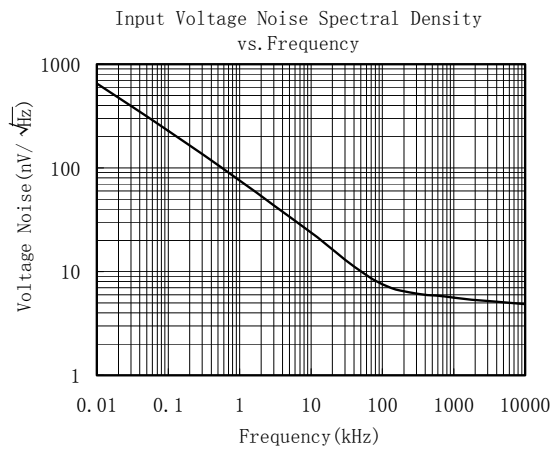
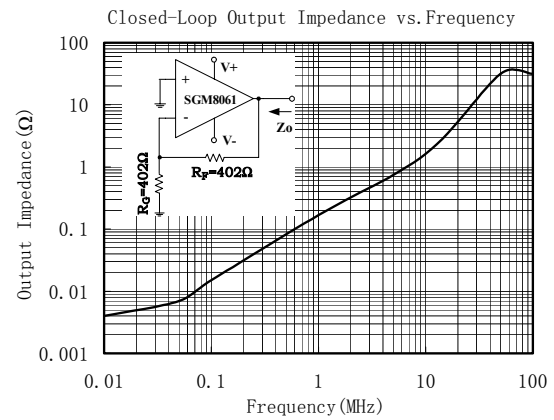
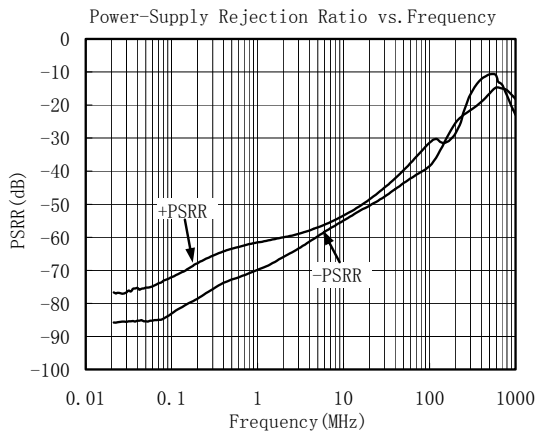
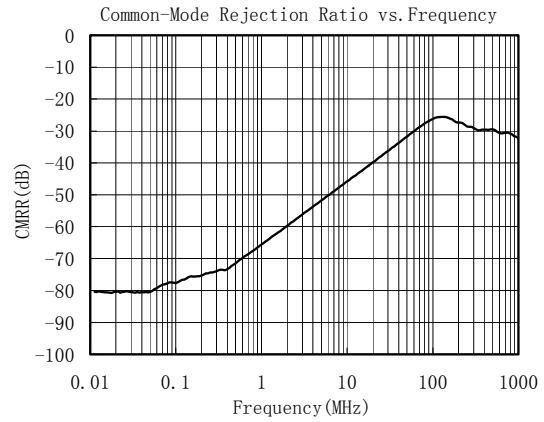
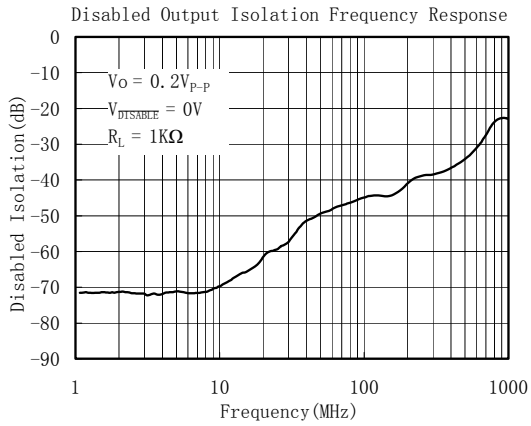

# TYPICAL PERFORMANCE CHARACTERISTICS

At  $T_A = +25^\circ\text{C}$ ,  $V_S = +5\text{V}$ ,  $G = +2$ ,  $R_F = 402\Omega$ ,  $R_G = 402\Omega$ , and  $R_L = 150\Omega$  connected to  $V_S/2$ , unless otherwise noted.

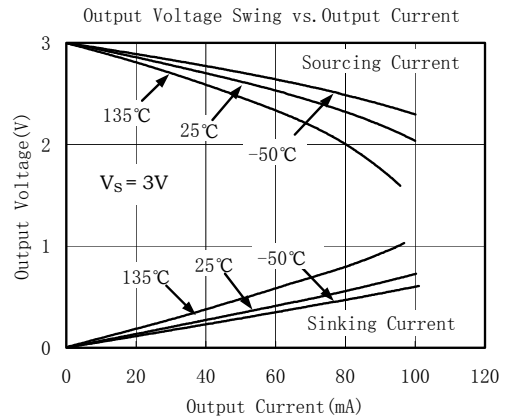
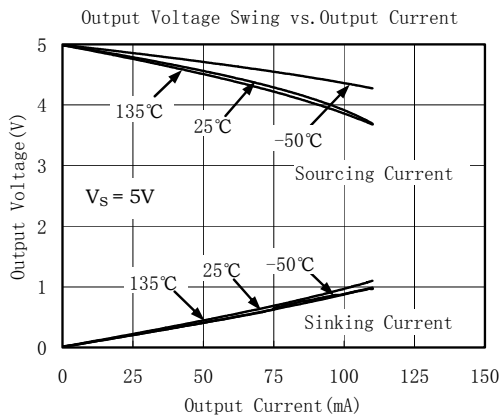
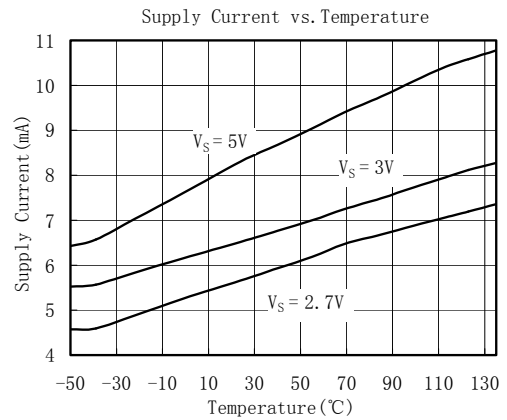
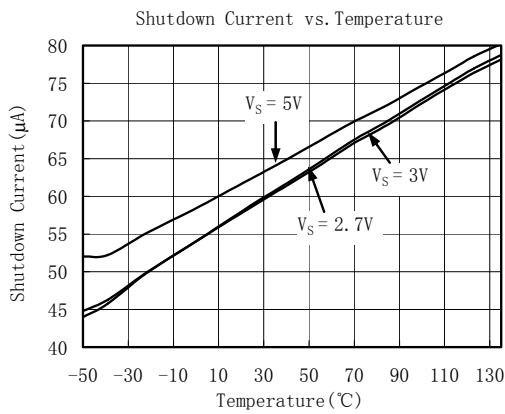
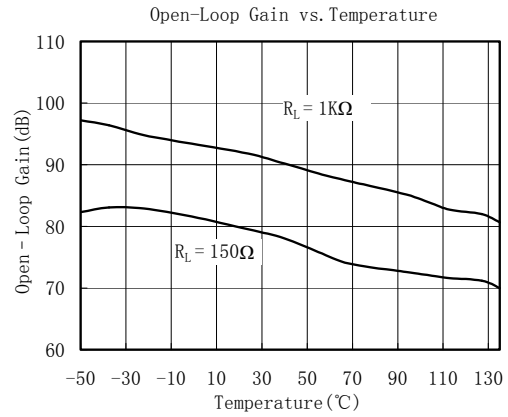
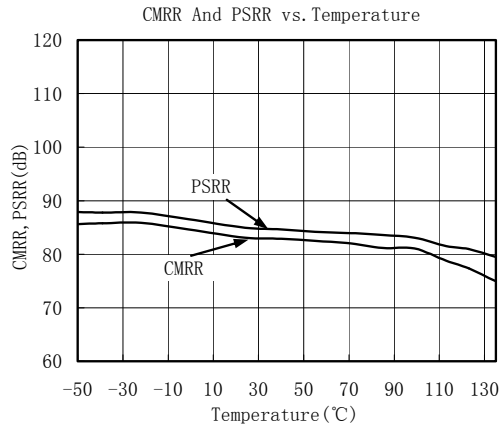

# TYPICAL PERFORMANCE CHARACTERISTICS

At  $T_A = +25^\circ\text{C}$ ,  $V_S = +5\text{V}$ ,  $G = +2$ ,  $R_F = 402\Omega$ ,  $R_G = 402\Omega$ , and  $R_L = 150\Omega$  connected to  $V_S/2$ , unless otherwise noted.

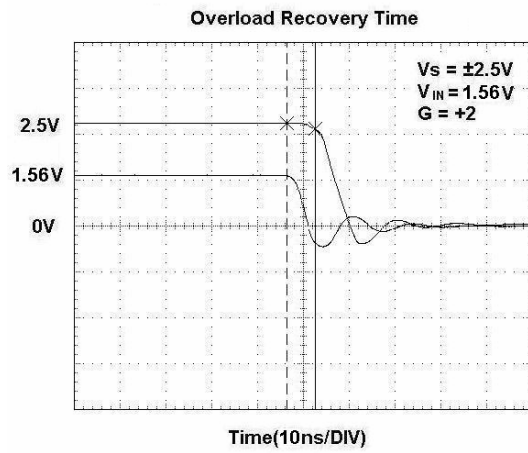



# APPLICATION NOTES

## Driving Capacitive Loads

The SGM806x family is optimized for bandwidth and speed, not for driving capacitive loads. Output capacitance will create a pole in the amplifier's feedback path, leading to excessive peaking and potential oscillation. If dealing with load capacitance is a requirement of the application, the two strategies to consider are (1) using a small resistor in series with the amplifier's output and the load capacitance and (2) reducing the bandwidth of the amplifier's feedback loop by increasing the overall noise gain.

Figure 1 shows a unity gain follower using the series resistor strategy. The resistor isolates the output from the capacitance and, more importantly, creates a zero in the feedback path that compensates for the pole created by the output capacitance.

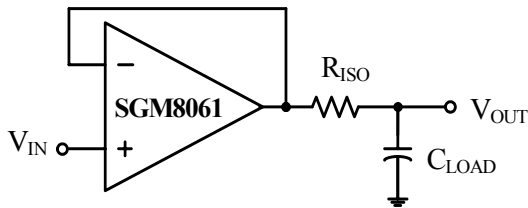

Figure 1. Series Resistor Isolating Capacitive Load

## Power-Supply Bypassing and Layout

The SGM806x family operates from either a single +2.7V to +5.5V supply or dual  $\pm 1.35V$  to  $\pm 2.75V$  supplies. For single-supply operation, bypass the power supply  $V_{DD}$  with a  $0.1\mu F$  ceramic capacitor which should be placed close to the  $V_{DD}$  pin. For dual-supply operation, both the  $V_{DD}$  and the  $V_{SS}$  supplies should be bypassed to ground with separate  $0.1\mu F$  ceramic capacitors.  $2.2\mu F$  tantalum capacitor can be added for better performance.

Good PC board layout techniques optimize performance by decreasing the amount of stray capacitance at the op amp's inputs and output. To decrease stray capacitance, minimize trace lengths and widths by placing external components as close to the device as possible. Use surface-mount components whenever possible.

For the high speed operational amplifier, soldering the part to the board directly is strongly recommended. Try to keep the high frequency big current loop area small to minimize the EMI (electromagnetic interfacing).

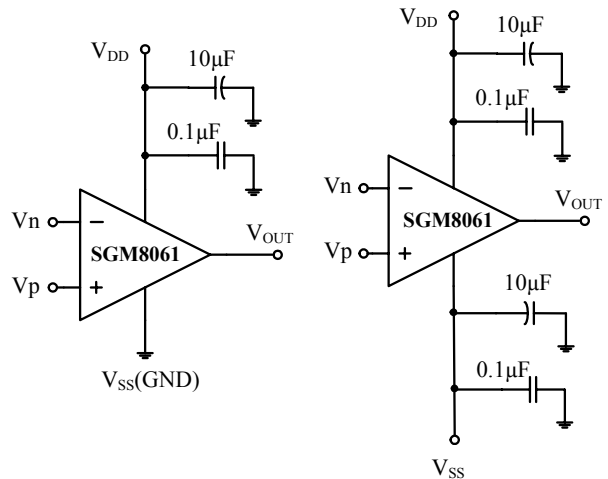

Figure 2. Amplifier with Bypass Capacitors

## Grounding

A ground plane layer is important for high speed circuit design. The length of the current path speed currents in an inductive ground return will create an unwanted voltage noise. Broad ground plane areas will reduce the parasitic inductance.

## Input-to-Output Coupling

To minimize capacitive coupling, the input and output signal traces should not be parallel. This helps reduce unwanted positive feedback.

# Typical Application Circuits

## Differential Amplifier

The circuit shown in Figure 3 performs the difference function. If the resistors ratios are equal ( $R_4 / R_3 = R_2 / R_1$ ), then  $V_{OUT} = (V_p - V_n) \times R_2 / R_1 + V_{ref}$ .

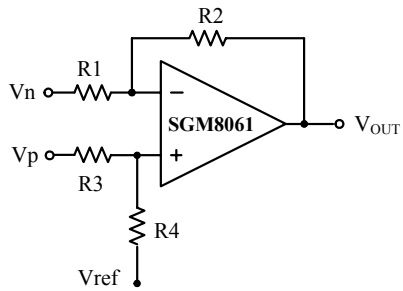

Figure 3. Differential Amplifier

## Low Pass Active Filter

The low pass filter shown in Figure 4 has a DC gain of  $(-R_2 / R_1)$  and the  $-3\text{dB}$  corner frequency is  $1/2\pi R_2 C$ . Make sure the filter is within the bandwidth of the amplifier. The Large values of feedback resistors can couple with parasitic capacitance and cause undesired effects such as ringing or oscillation in high-speed amplifiers. Keep resistors value as low as possible and consistent with output loading consideration.

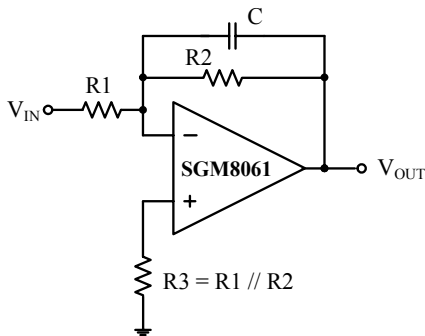
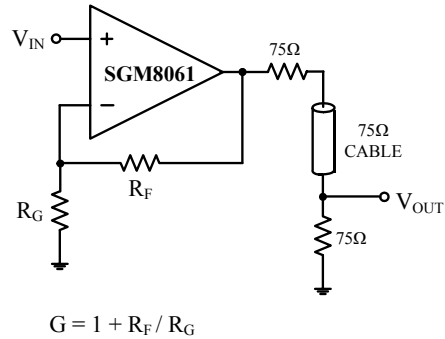

Figure 4. Low Pass Active Filter

## Driving Video

The SGM806x can be used in video applications like in Figure 5.



$$G = 1 + R_F / R_G$$

Figure 5. Typical Video Driving

# PACKAGE OUTLINE DIMENSIONS

## SOT23-5

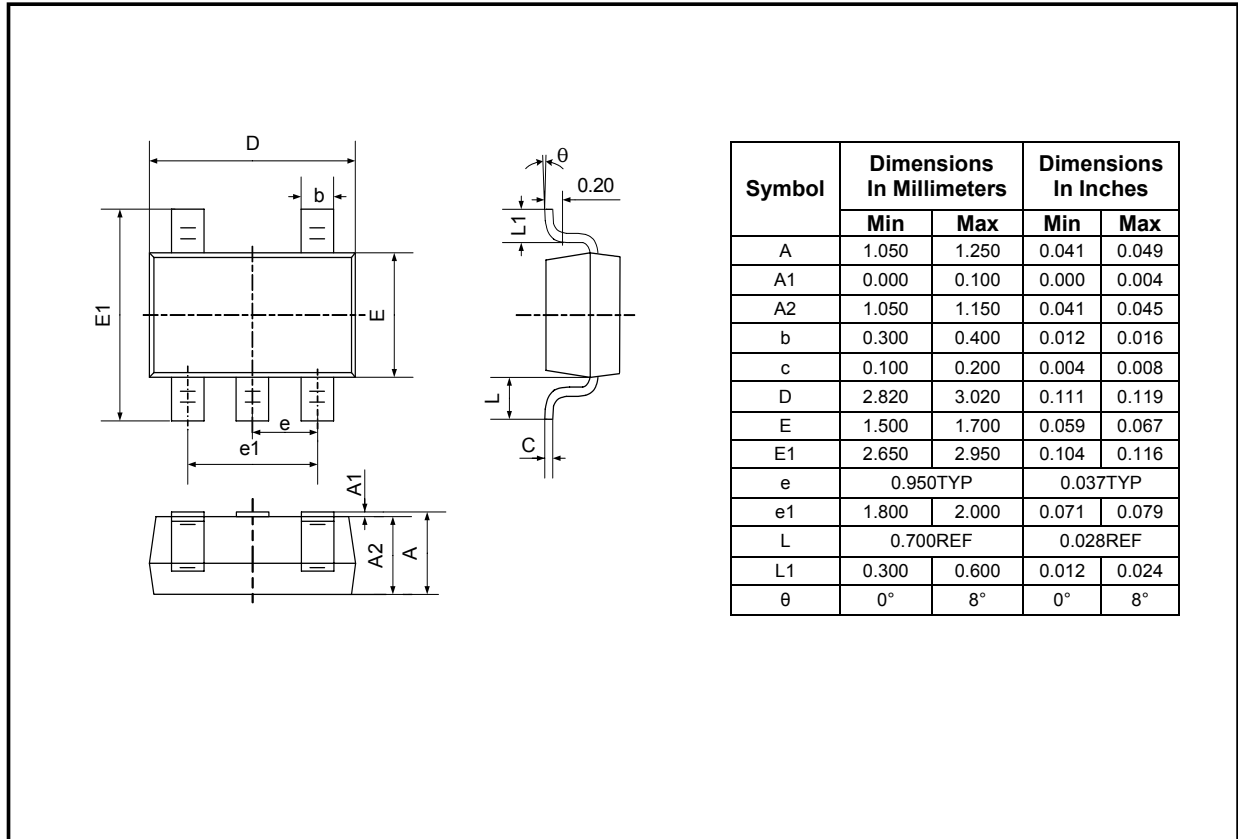

Symbol	Dimensions In Millimeters		Dimensions In Inches	
	Min	Max	Min	Max
A	1.050	1.250	0.041	0.049
A1	0.000	0.100	0.000	0.004
A2	1.050	1.150	0.041	0.045
b	0.300	0.400	0.012	0.016
c	0.100	0.200	0.004	0.008
D	2.820	3.020	0.111	0.119
E	1.500	1.700	0.059	0.067
E1	2.650	2.950	0.104	0.116
e	0.950TYP		0.037TYP	
e1	1.800	2.000	0.071	0.079
L	0.700REF		0.028REF	
L1	0.300	0.600	0.012	0.024
theta	0°	8°	0°	8°

# PACKAGE OUTLINE DIMENSIONS

## SOT23-6

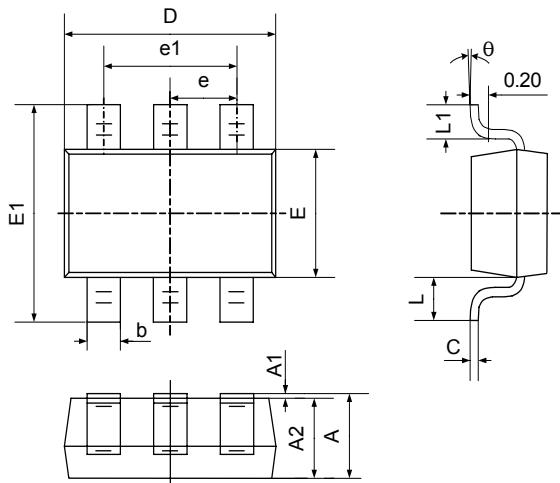

Symbol	Dimensions In Millimeters		Dimensions In Inches	
	Min	Max	Min	Max
A	1.050	1.250	0.041	0.049
A1	0.000	0.100	0.000	0.004
A2	1.050	1.150	0.041	0.045
b	0.300	0.400	0.012	0.016
c	0.100	0.200	0.004	0.008
D	2.820	3.020	0.111	0.119
E	1.500	1.700	0.059	0.067
E1	2.650	2.950	0.104	0.116
e	0.950TYP		0.037TYP	
e1	1.800	2.000	0.071	0.079
L	0.700REF		0.028REF	
L1	0.300	0.600	0.012	0.024
$\theta$	0°	8°	0°	8°

# PACKAGE OUTLINE DIMENSIONS

## SO-8

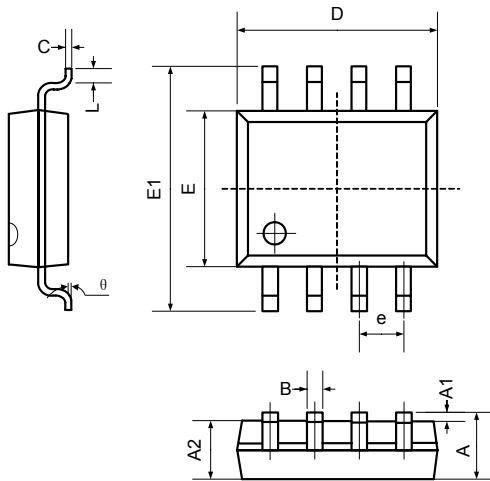

Symbol	Dimensions In Millimeters		Dimensions In Inches	
	Min	Max	Min	Max
A	1.350	1.750	0.053	0.069
A1	0.100	0.250	0.004	0.010
A2	1.350	1.550	0.053	0.061
B	0.330	0.510	0.013	0.020
C	0.190	0.250	0.007	0.010
D	4.780	5.000	0.188	0.197
E	3.800	4.000	0.150	0.157
E1	5.800	6.300	0.228	0.248
e	1.270TYP		0.050TYP	
L	0.400	1.270	0.016	0.050
$\theta$	0°	8°	0°	8°

# REVISION HISTORY

Location	Page
11/06— Data Sheet changed from Preliminary to REV. A	
Changes to ABSOLUTE MAXIMUM RATINGS .....	3

## **SGMICRO**

---

SGMICRO is dedicated to provide high quality and high performance analog IC products to customers. All SGMICRO products meet the highest industry standards with strict and comprehensive test and quality control systems to achieve world-class consistency and reliability.

For information regarding SGMICRO Corporation and its products, see [www.sg-micro.com](http://www.sg-micro.com)