

SGM8541 SGM8542 SGM8544

1.1MHz, 42µA, Rail-to-Rail I/O CMOS Operational Amplifier

PRODUCT DESCRIPTION

The SGM8541 (single) , SGM8542 (dual) and SGM8544 (quad) are rail-to-rail input and output voltage feedback amplifiers offering low cost. They have a wide input common-mode voltage range and output voltage swing, and take the minimum operating supply voltage down to 2.1V and the maximum recommended supply voltage is 5.5 V. All are specified over the extended -40°C to $+125^{\circ}\text{C}$ temperature range.

The SGM8541/8542/8544 provide 1.1MHz bandwidth at a low current consumption of 42µA per amplifier. Very low input bias currents of 0.5pA, enable SGM8541/8542 /8544 to be used for integrators, photodiode amplifiers, and piezoelectric sensors. Rail-to-rail inputs and outputs are useful to designers buffering ASIC in single-supply systems.

Applications for this amplifiers include safety monitoring, portable equipment, battery and power supply control, and signal conditioning and interfacing for transducers in very low power systems.

The SGM8541 is available in the tiny SOT23-5, SC70-5 and SO-8 packages. The SGM8542 comes in the miniature SO-8 and MSOP-8 packages. The SGM8544 is offered in TSSOP-16 and SO-16 packages.

APPLICATIONS

ASIC Input or Output Amplifier
Sensor Interface
Piezo Electric Transducer Amplifier
Medical Instrumentation
Mobile Communication
Audio Output
Portable Systems
Smoke Detectors
Mobile Telephone
Notebook PC
PCMCIA cards
Battery -Powered equipment

FEATURES

- Low Cost
- Rail-to-Rail Input and Output
0.8mV Typical V_{os}
- Unity Gain Stable
- Gain Bandwidth Product : 1.1MHz
- Very low input bias currents : 0.5pA
- Operates on 2.1 V to 5.5 V Supplies
- Input Voltage Range = - 0.1 V to +5.6 V with $V_s = 5.5$ V
- Low Supply Current: 42µA/Amplifier
- Small Packaging
SGM8541 Available in SO-8, SC70-5 and SOT23-5
SGM8542 Available in SO-8 and MSOP-8
SGM8544 Available in SO-16 and TSSOP-16

PIN CONFIGURATIONS (Top View)

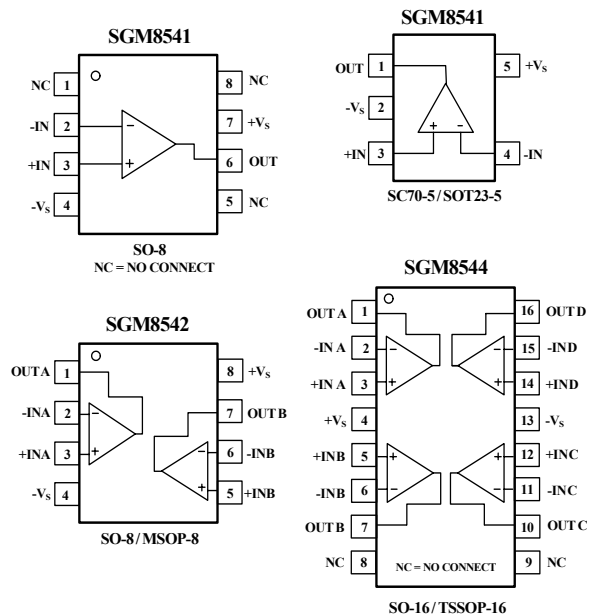

ELECTRICAL CHARACTERISTICS : $V_S = +5V$

(At $R_L = 100k\Omega$ connected to $V_S/2$, and $V_{OUT} = V_S/2$, unless otherwise noted)

| PARAMETER | CONDITION | SGM8541/8542/8544 | | | | | | | |
|---|--|-------------------|--------------------------|-------------|---------------|----------------|------------------|-------|---------|
| | | TYP | MIN/MAX OVER TEMPERATURE | | | | | UNITS | MIN/MAX |
| | | +25°C | +25°C | 0°C to 70°C | -40°C to 85°C | -40°C to 125°C | | | |
| INPUT CHARACTERISTICS | | | | | | | | | |
| Input Offset Voltage (V_{OS}) | | ±0.8 | ±3.5 | ±3.7 | ±4.1 | ±5.4 | mV | MAX | |
| Input Bias Current (I_B) | | 0.5 | | | | | pA | TYP | |
| Input Offset Current (I_{OS}) | | 0.5 | | | | | pA | TYP | |
| Common-Mode Voltage Range (V_{CM}) | $V_S = 5.5V$ | -0.1 to +5.6 | | | | | V | TYP | |
| Common-Mode Rejection Ratio (CMRR) | $V_S = 5.5V, V_{CM} = -0.1V$ to 4 V | 88 | 72 | 72 | 72 | 72 | dB | MIN | |
| | $V_S = 5.5V, V_{CM} = -0.1V$ to 5.6 V | 78 | 60 | 59 | 59 | 57 | dB | MIN | |
| Open-Loop Voltage Gain (A_{OL}) | $R_L = 5K\Omega, V_o = 0.1V$ to 4.9V | 90 | 80 | 80 | 80 | 78 | dB | MIN | |
| | $R_L = 100K\Omega, V_o = 0.035V$ to 4.965V | 94 | 85 | 85 | 85 | 82 | dB | MIN | |
| Input Offset Voltage Drift ($\Delta V_{OS}/\Delta T$) | | 2.7 | | | | | $\mu V/^\circ C$ | TYP | |
| OUTPUT CHARACTERISTICS | | | | | | | | | |
| Output Voltage Swing from Rail | $R_L = 100K\Omega$ | 0.008 | | | | | V | TYP | |
| Output Current (I_{OUT}) | | 23 | 20 | 19.1 | 18.8 | 18 | mA | MIN | |
| POWER SUPPLY | | | | | | | | | |
| Operating Voltage Range | | | 2.1 | 2.5 | 2.5 | 2.5 | V | MIN | |
| | | | 5.5 | 5.5 | 5.5 | 5.5 | V | MAX | |
| Power Supply Rejection Ratio (PSRR) | $V_S = +2.5 V$ to + 5.5 V | | | | | | | | |
| | $V_{CM} = (-V_S) + 0.5$ | 92 | 76 | 74 | 71 | 70 | dB | MIN | |
| Quiescent Current / Amplifier (I_Q) | $I_{OUT} = 0$ | 42 | 54 | 59 | 60 | 64 | μA | MAX | |
| DYNAMIC PERFORMANCE | | | | | | | | | |
| Gain-Bandwidth Product (GBP) | $C_L = 100pF$ | 1.1 | | | | | MHz | TYP | |
| Slew Rate (SR) | $G = +1, 2V$ Output Step | 0.52 | | | | | V/ μs | TYP | |
| Settling Time to 0.1% (t_S) | $G = +1, 2 V$ Output Step | 5.3 | | | | | μs | TYP | |
| Overload Recovery Time | $V_{IN} \cdot Gain = V_S$ | 2.6 | | | | | μs | TYP | |
| NOISE PERFORMANCE | | | | | | | | | |
| Voltage Noise Density (e_n) | $f = 1kHz$ | 27 | | | | | nV/\sqrt{Hz} | TYP | |
| | $f = 10kHz$ | 20 | | | | | nV/\sqrt{Hz} | TYP | |

Specifications subject to change without notice.

PACKAGE/ORDERING INFORMATION

| MODEL | ORDER NUMBER | PACKAGE DESCRIPTION | PACKAGE OPTION | MARKING INFORMATION |
|---------|---------------|---------------------|---------------------|---------------------|
| SGM8541 | SGM8541XC5/TR | SC70-5 | Tape and Reel, 3000 | 8541 |
| | SGM8541XN5/TR | SOT23-5 | Tape and Reel, 3000 | 8541 |
| | SGM8541XS/TR | SO-8 | Tape and Reel, 2500 | SGM8541XS |
| SGM8542 | SGM8542XS/TR | SO-8 | Tape and Reel, 2500 | SGM8542XS |
| | SGM8542XMS/TR | MSOP-8 | Tape and Reel, 3000 | SGM8542XMS |
| SGM8544 | SGM8544XS/TR | SO-16 | Tape and Reel, 2500 | SGM8544XS |
| | SGM8544XTS/TR | TSSOP-16 | Tape and Reel, 3000 | SGM8544XTS |

Note: SC70-5 package is same as SOT-353 package.

ABSOLUTE MAXIMUM RATINGS

| | |
|---|-----------------|
| Supply Voltage, V+ to V- | 7.5 V |
| Common-Mode Input Voltage | |
|(-V _S) - 0.5 V to (+V _S) +0.5V | |
| Storage Temperature Range | -65°C to +150°C |
| Junction Temperature | 150°C |
| Operating Temperature Range | -55°C to +150°C |
| Package Thermal Resistance @ T _A = 25°C | |
| SC70-5, θ _{JA} | 333°C/W |
| SOT23-5, θ _{JA} | 190°C/W |
| SO-8, θ _{JA} | 125°C/W |
| MSOP-8, θ _{JA} | 216°C/W |
| SO-16, θ _{JA} | 82°C/W |
| TSSOP-16, θ _{JA} | 105°C/W |
| Lead Temperature Range (Soldering 10 sec) | |
| | 260°C |
| ESD Susceptibility | |
| HBM | 4000V |
| MM | 400V |

NOTES

1. Stresses above those listed under Absolute Maximum Ratings may cause permanent damage to the device. This is a stress rating only; functional operation of the device at these or any other conditions above those indicated in the operational section of this specification is not implied. Exposure to absolute maximum rating conditions for extended periods may affect device reliability.

CAUTION

This integrated circuit can be damaged by ESD. SGMICRO recommends that all integrated circuits be handled with appropriate precautions. Failure to observe proper handling and installation procedures can cause damage.

ESD damage can range from subtle performance degradation to complete device failure. Precision integrated circuits may be more susceptible to damage because very small parametric changes could cause the device not to meet its published specifications.

TYPICAL PERFORMANCE CHARACTERISTICS

At $T_A = +25^\circ\text{C}$, $V_S = +5\text{V}$, and $R_L = 100\text{k}\Omega$ connected to $V_S/2$, unless otherwise noted.

Small-Signal Step Response

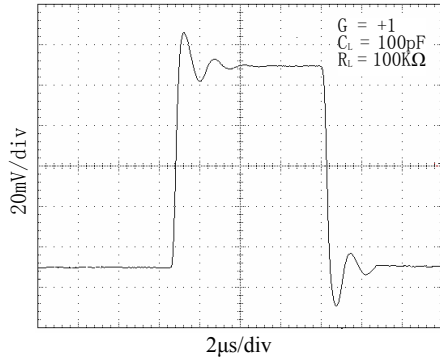

Large-Signal Step Response

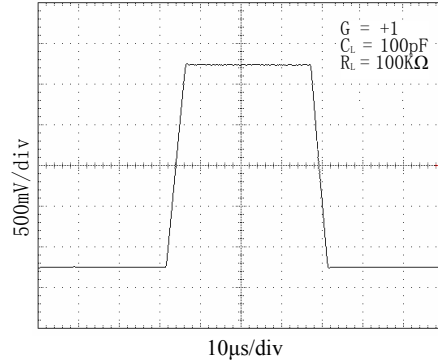

Small-Signal Overshoot vs. Load Capacitance

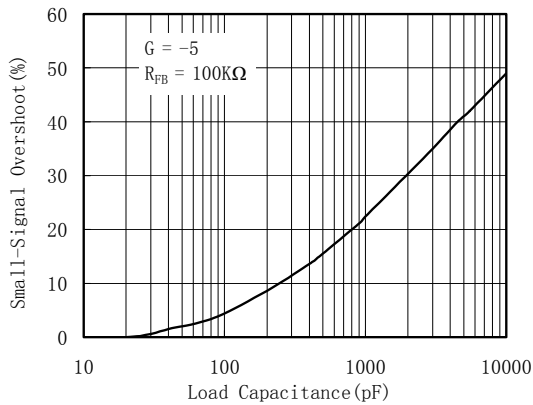

Small-Signal Overshoot vs. Load Capacitance

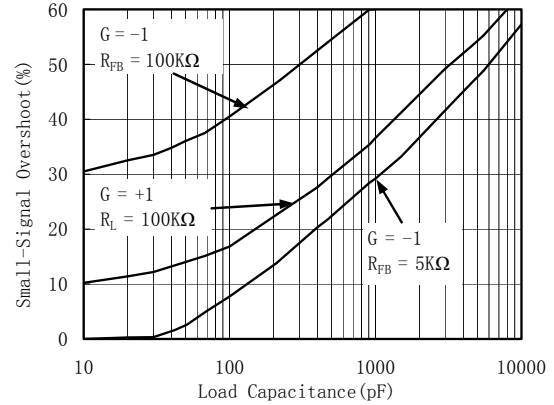

Maximum Output Voltage vs. Frequency

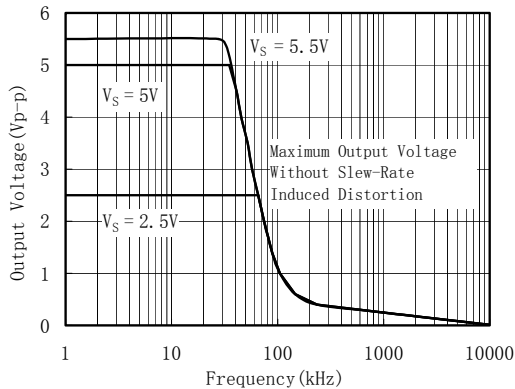

Quiescent And Short-Circuit Current vs. Supply Voltage

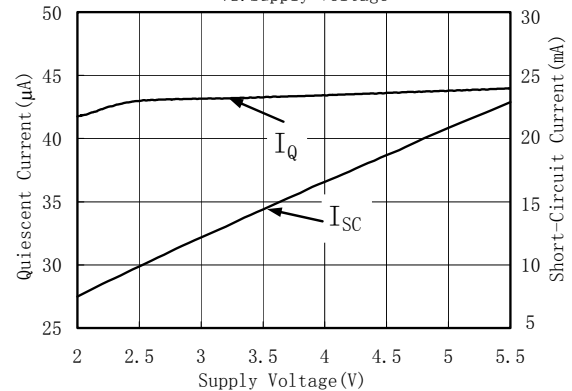

TYPICAL PERFORMANCE CHARACTERISTICS

At $T_A = +25^\circ\text{C}$, $V_S = +5\text{V}$, and $R_L = 100\text{k}\Omega$ connected to $V_S/2$, unless otherwise noted.

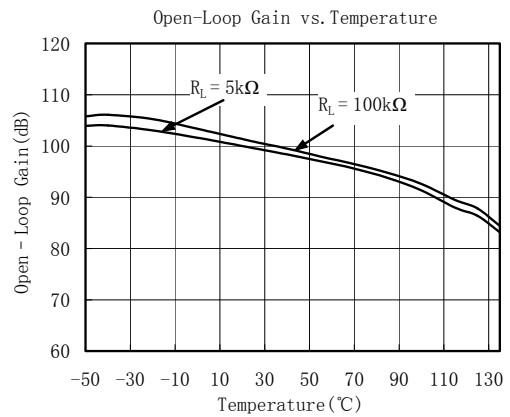
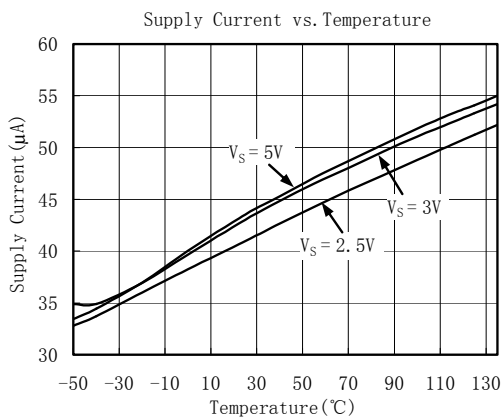
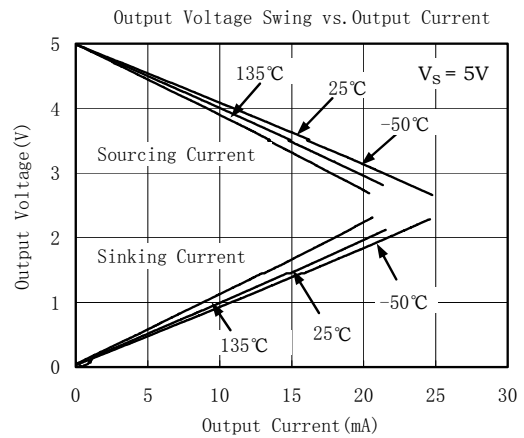
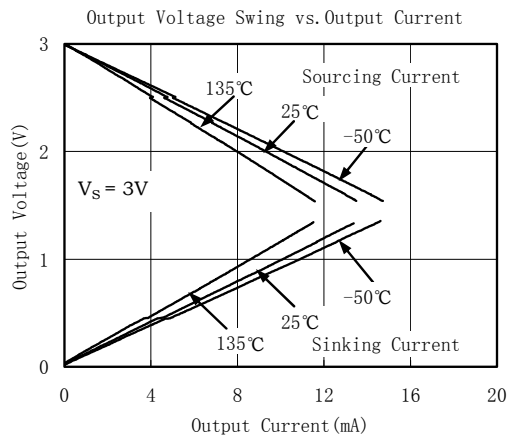
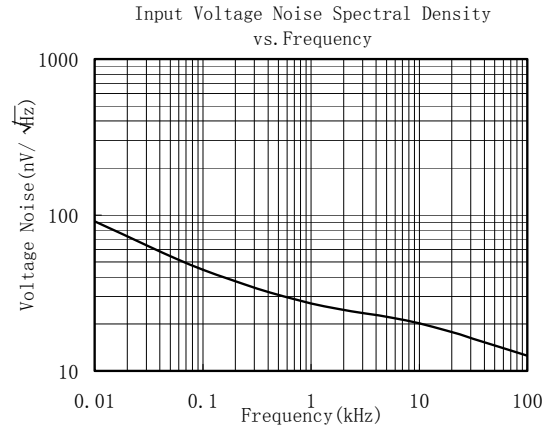
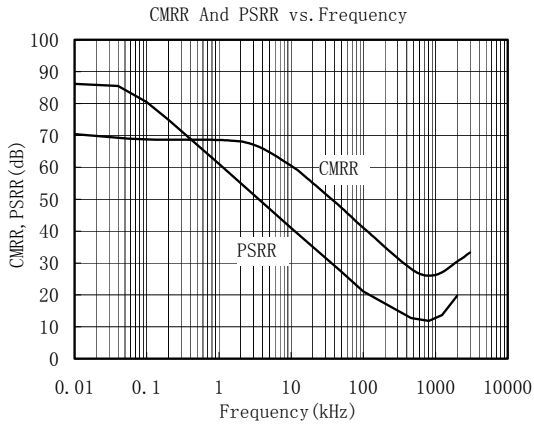

TYPICAL PERFORMANCE CHARACTERISTICS

At $T_A = +25^\circ\text{C}$, $V_S = +5\text{V}$, and $R_L = 100\text{k}\Omega$ connected to $V_S/2$, unless otherwise noted.

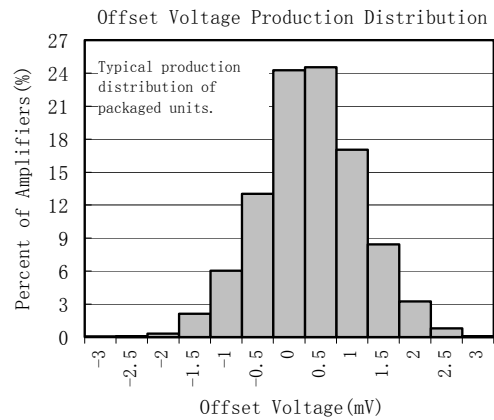
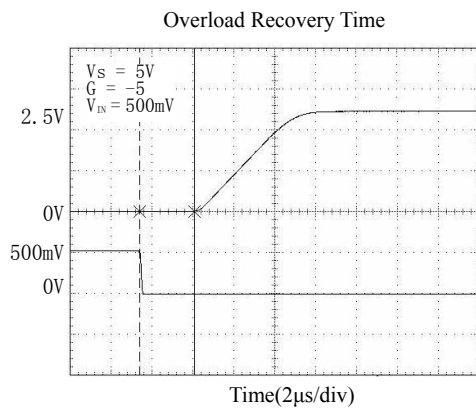
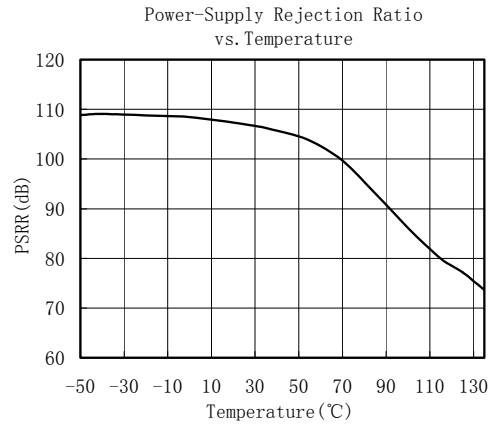
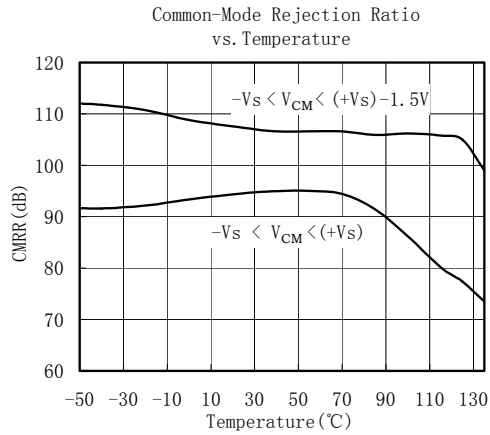

APPLICATION NOTES

Driving Capacitive Loads

The SGM854X can directly drive 250pF in unity-gain without oscillation. The unity-gain follower (buffer) is the most sensitive configuration to capacitive loading. Direct capacitive loading reduces the phase margin of amplifiers and this results in ringing or even oscillation. Applications that require greater capacitive drive capability should use an isolation resistor between the output and the capacitive load like the circuit in Figure 1. The isolation resistor R_{ISO} and the load capacitor C_L form a zero to increase stability. The bigger the R_{ISO} resistor value, the more stable V_{OUT} will be. Note that this method results in a loss of gain accuracy because R_{ISO} forms a voltage divider with the R_{LOAD} .

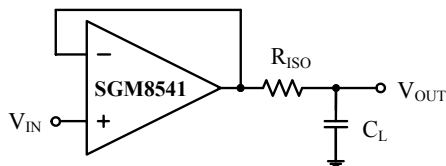

Figure 1. Indirectly Driving Heavy Capacitive Load

An improvement circuit is shown in Figure 2. It provides DC accuracy as well as AC stability. R_F provides the DC accuracy by connecting the inverting signal with the output, C_F and R_{ISO} serve to counteract the loss of phase margin by feeding the high frequency component of the output signal back to the amplifier's inverting input, thereby preserving phase margin in the overall feedback loop.

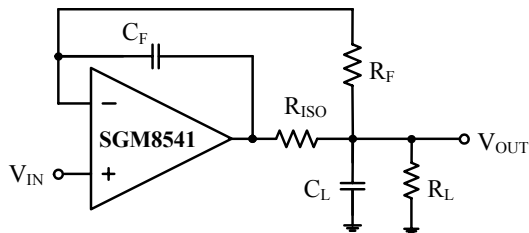

Figure 2. Indirectly Driving Heavy Capacitive Load with DC Accuracy

For no-buffer configuration, there are two others ways to increase the phase margin: (a) by increasing the amplifier's gain or (b) by placing a capacitor in parallel with the feedback resistor to counteract the parasitic capacitance associated with inverting node.

Power-Supply Bypassing and Layout

The SGM854X family operates from either a single +2.5V to +5.5V supply or dual $\pm 1.25V$ to $\pm 2.75V$ supplies. For single-supply operation, bypass the power supply V_{DD} with a $0.1\mu F$ ceramic capacitor which should be placed close to the V_{DD} pin. For dual-supply operation, both the V_{DD} and the V_{SS} supplies should be bypassed to ground with separate $0.1\mu F$ ceramic capacitors. $2.2\mu F$ tantalum capacitor can be added for better performance.

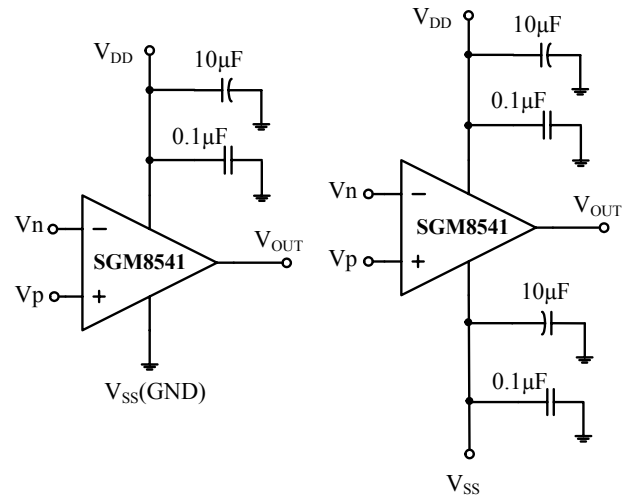

Figure 3. Amplifier with Bypass Capacitors

Typical Application Circuits

Differential Amplifier

The circuit shown in Figure 4 performs the difference function. If the resistors ratios are equal ($R4 / R3 = R2 / R1$), then $V_{OUT} = (Vp - Vn) \times R2 / R1 + Vref$.

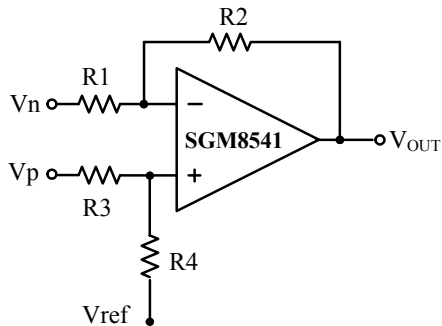

Figure 4. Differential Amplifier

Instrumentation Amplifier

The circuit in Figure 5 performs the same function as that in Figure 4 but with the high input impedance.

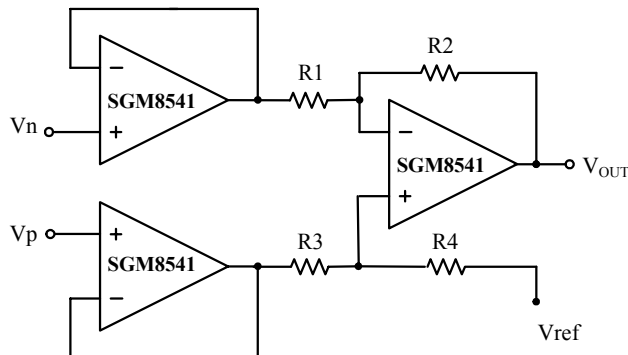

Figure 5. Instrumentation Amplifier

Low Pass Active Filter

The low pass filter shown in Figure 6 has a DC gain of $(-R2 / R1)$ and the $-3dB$ corner frequency is $1/2\pi R2C$. Make sure the filter is within the bandwidth of the amplifier. The Large values of feedback resistors can couple with parasitic capacitance and cause undesired effects such as ringing or oscillation in high-speed amplifiers. Keep resistors value as low as possible and consistent with output loading consideration.

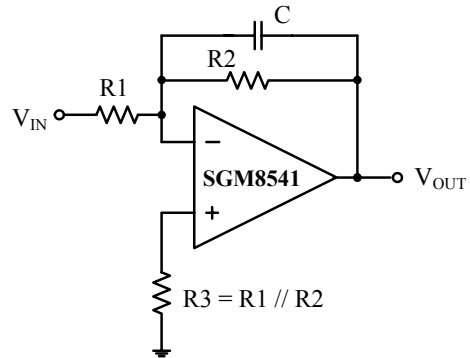
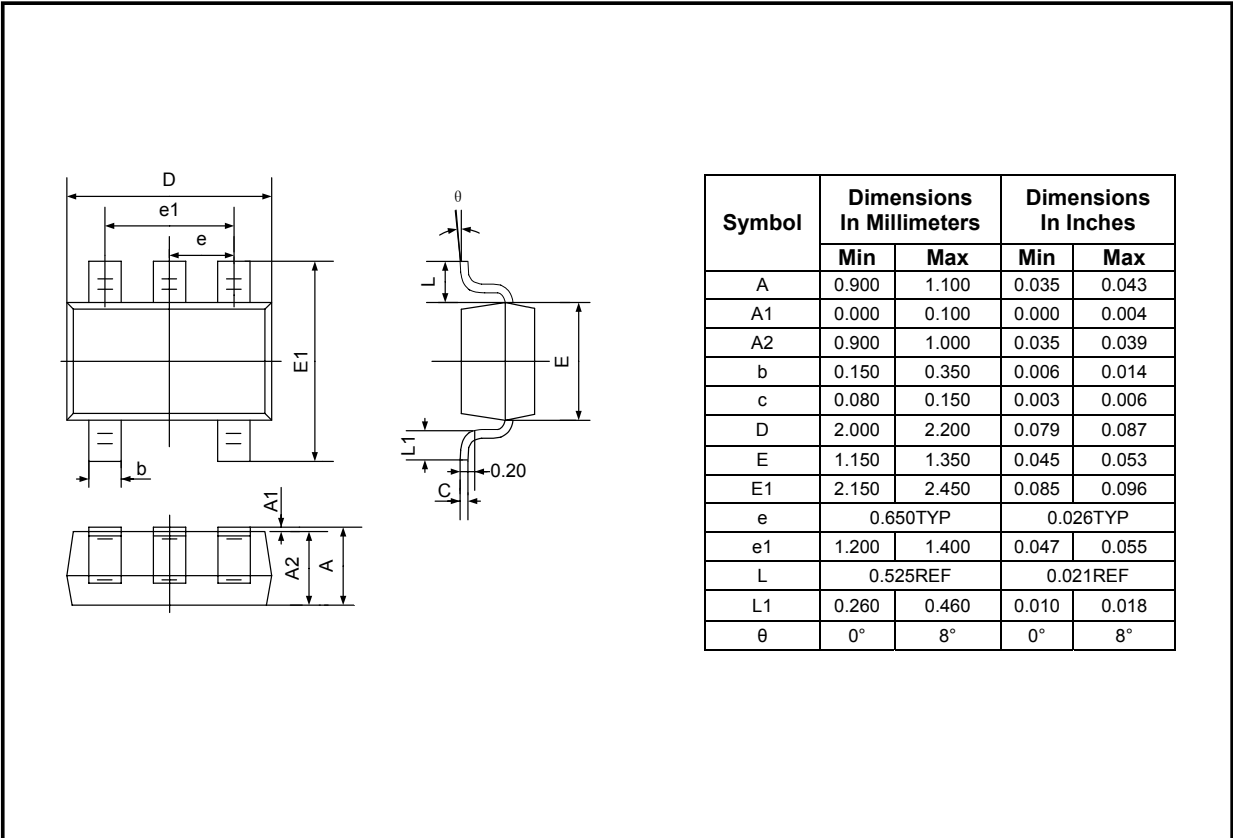

Figure 6. Low Pass Active Filter

PACKAGE OUTLINE DIMENSIONS

SC70-5 / SOT-353



PACKAGE OUTLINE DIMENSIONS

SOT23-5

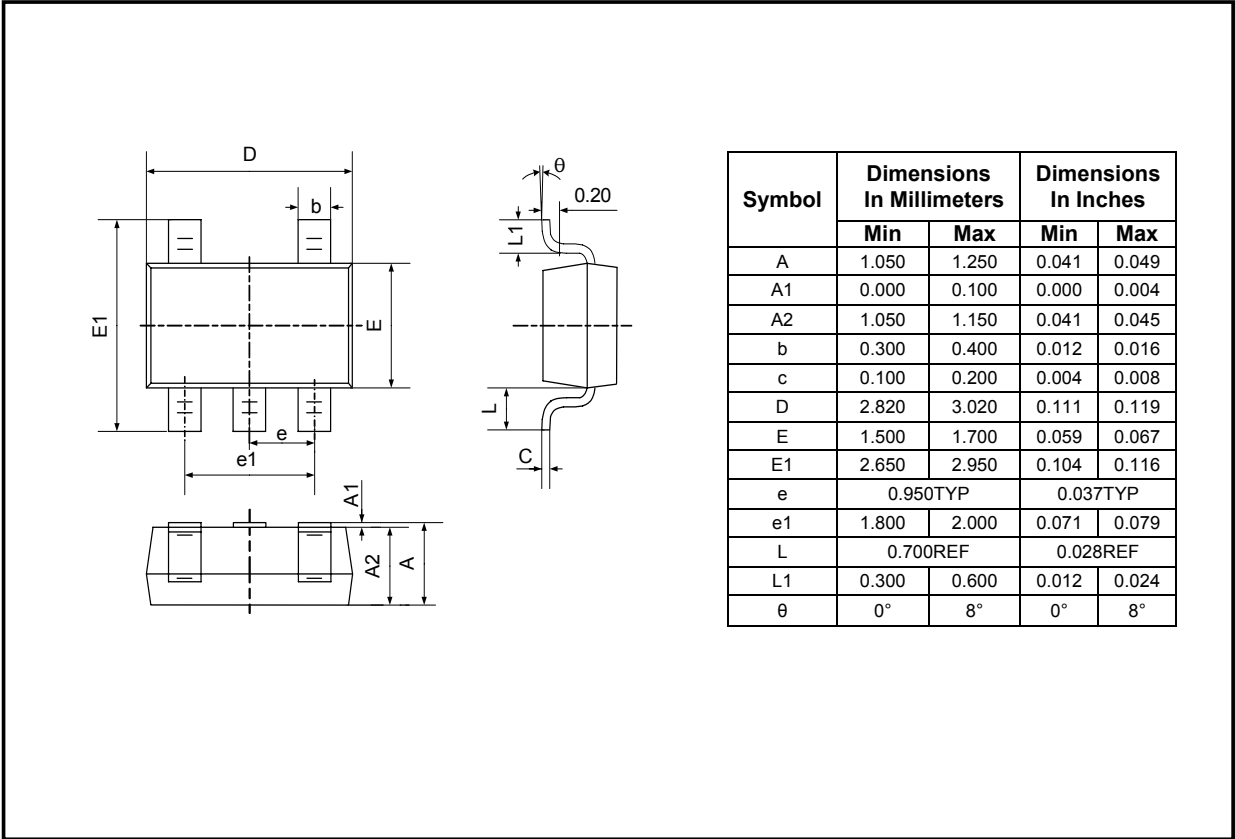

PACKAGE OUTLINE DIMENSIONS

SO-8

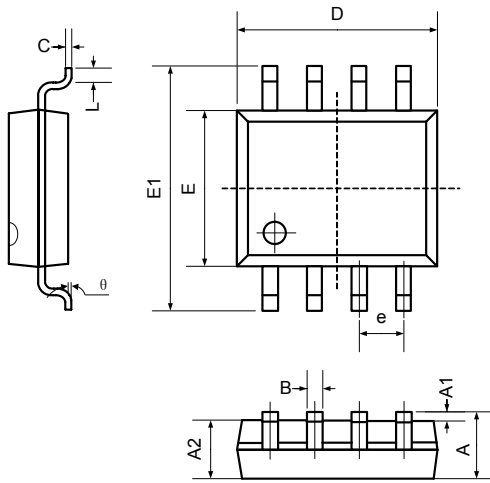

| Symbol | Dimensions In Millimeters | | Dimensions In Inches | |
|--------|---------------------------|-------|----------------------|-------|
| | Min | Max | Min | Max |
| A | 1.350 | 1.750 | 0.053 | 0.069 |
| A1 | 0.100 | 0.250 | 0.004 | 0.010 |
| A2 | 1.350 | 1.550 | 0.053 | 0.061 |
| B | 0.330 | 0.510 | 0.013 | 0.020 |
| C | 0.190 | 0.250 | 0.007 | 0.010 |
| D | 4.780 | 5.000 | 0.188 | 0.197 |
| E | 3.800 | 4.000 | 0.150 | 0.157 |
| E1 | 5.800 | 6.300 | 0.228 | 0.248 |
| e | 1.270TYP | | 0.050TYP | |
| L | 0.400 | 1.270 | 0.016 | 0.050 |
| θ | 0° | 8° | 0° | 8° |

PACKAGE OUTLINE DIMENSIONS

MSOP-8

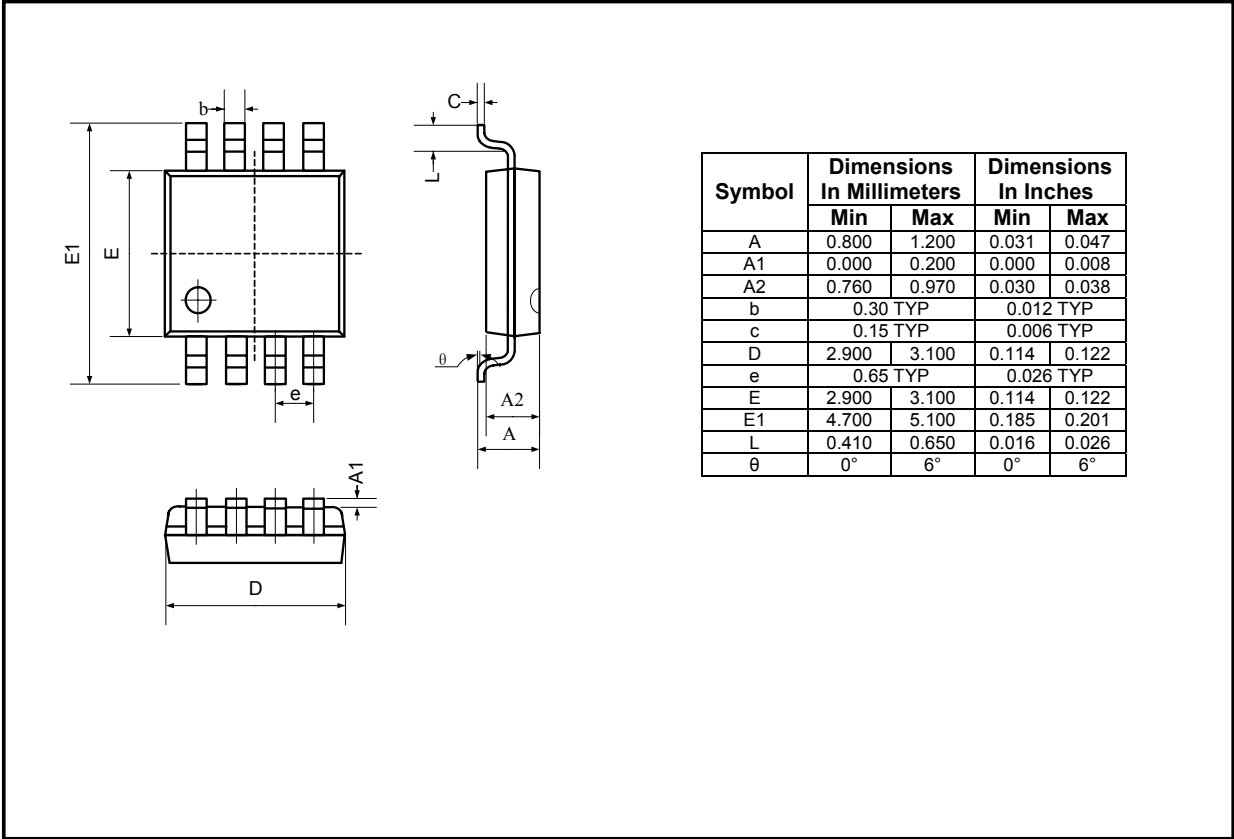

PACKAGE OUTLINE DIMENSIONS

SO-16

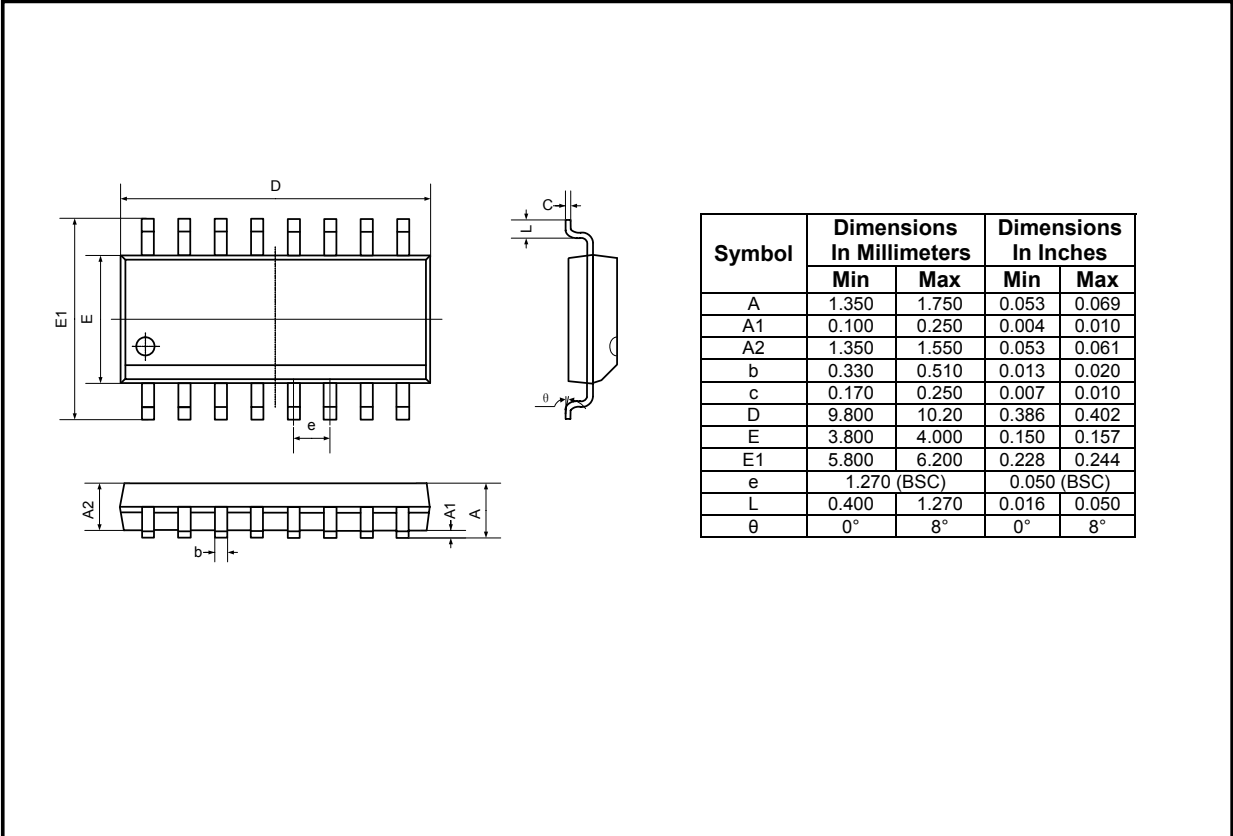

PACKAGE OUTLINE DIMENSIONS

TSSOP-16

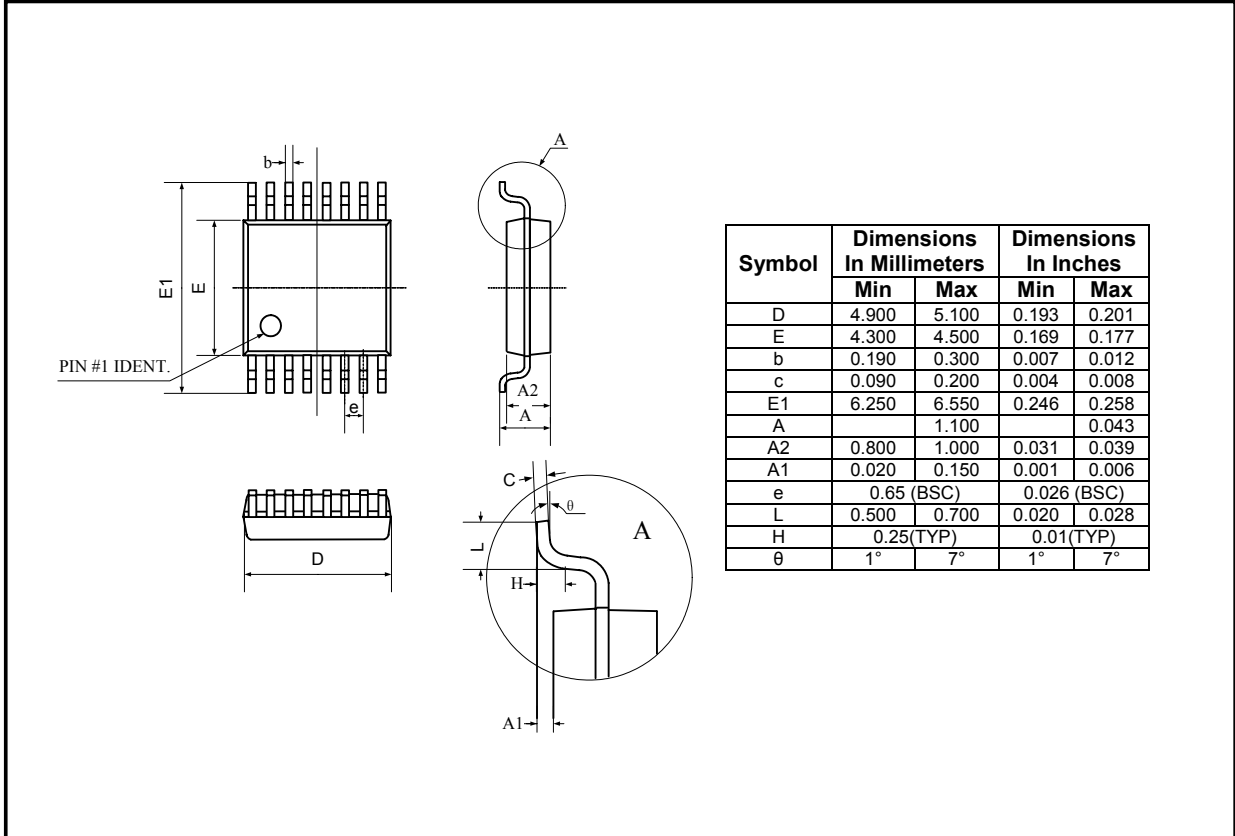

REVISION HISTORY

| Location | Page |
|--|------|
| 11/06 – Data Sheet changed from REV. A to REV. B | |
| Changes to ABSOLUTE MAXIMUM RATINGS | 3 |
| 06/08 – Data Sheet changed from REV. B to REV. B. 1 | |
| Added SGM8541XC5 | 1, 3 |

SGMICRO

SGMICRO is dedicated to provide high quality and high performance analog IC products to customers. All SGMICRO products meet the highest industry standards with strict and comprehensive test and quality control systems to achieve world-class consistency and reliability.

For information regarding SGMICRO Corporation and its products, see www.sg-micro.com