



# SGM8922

## 12.7MHz, Dual Rail-to-Rail Output Operational Amplifier

### PRODUCT DESCRIPTION

The SGM8922 is a dual, rail-to-rail output operational amplifier that is optimized and fully specified for 5V operation. High output current allows low load impedances to be driven.

The SGM8922 has a wide input common-mode voltage range and output voltage swing, running at single supply voltage from 3V to 5.5V.

The SGM8922 provides excellent overall performance. It exhibits low noise and distortion, low offset and high output current capability, making this device an excellent choice for high quality, low voltage or battery operated audio systems.

The SGM8922 is offered in (Pb)-free MSOP-8 and SO-8 packages and ESD (HBM) reaches 8KV. It is specified over the extended  $-40^{\circ}\text{C}$  to  $+85^{\circ}\text{C}$  temperature range.

### FEATURES

- Rail-to-Rail Output
- Low Noise:  $6\text{nV}/\sqrt{\text{Hz}}$
- Low Distortion
- High Output Voltage Swing: 4.73V (with 100mA Output Current)
- Low Output Voltage Swing: 0.24V (with 100mA Output Current)
- Supply Voltage Range: 3V to 5.5V
- Low Input Offset Voltage: 0.9mV MAX (SGM8922A)
- Gain Bandwidth Product: 12.7MHz
- Slew Rate: 6.8V/ $\mu\text{s}$
- Low Power 3mA/Amplifier Typical Supply Current
- Small Packaging: Available in Lead (Pb)-Free MSOP-8 and SO-8

### APPLICATIONS

Data Acquisition  
Process Control  
Active Filters  
Test Equipment  
Mobile Phone  
Audio Processing  
Video Processing  
Headphone Amplifier  
Portable Equipment  
Broadband Communications  
A-to-D Driver  
D-to-A Driver



SG Micro Limited  
[www.sg-micro.com](http://www.sg-micro.com)

REV. A. 1

PACKAGE/ORDERING INFORMATION

MODEL	PIN-PACKAGE	SPECIFIED TEMPERATURE RANGE	ORDERING NUMBER	PACKAGE MARKING	PACKAGE OPTION
SGM8922	MSOP-8	-40°C to +85°C	SGM8922YMS8/TR	SGM8922YMS8	Tape and Reel, 3000
	SO-8	-40°C to +85°C	SGM8922YS8/TR	SGM8922YS8	Tape and Reel, 2500
SGM8922A	MSOP-8	-40°C to +85°C	SGM8922AYMS8/TR	SGM8922YMS8	Tape and Reel, 3000
	SO-8	-40°C to +85°C	SGM8922AYS8/TR	SGM8922YS8	Tape and Reel, 2500

ABSOLUTE MAXIMUM RATINGS

Supply Voltage, +V<sub>S</sub> to -V<sub>S</sub> .....6V  
 Common-Mode Input Voltage..... -0.1V to 3.8V  
 Storage Temperature Range.....-65°C to 150°C  
 Junction Temperature .....160°C  
 Operating Temperature Range..... -40°C to 85°C  
 Package Thermal Resistance @ T<sub>A</sub> = 25°C  
 SO-8, θ<sub>JA</sub>.....82°C/W  
 MSOP-8, θ<sub>JA</sub>..... 105°C/W  
 Lead Temperature Range (Soldering 10 sec)  
 .....260°C  
 ESD Susceptibility  
 HBM.....8000V  
 MM.....400V

NOTES

1. Stresses above those listed under Absolute Maximum Ratings may cause permanent damage to the device. This is a stress rating only; functional operation of the device at these or any other conditions above those indicated in the operational section of this specification is not implied. Exposure to absolute maximum rating conditions for extended periods may affect device reliability.

CAUTION

This integrated circuit can be damaged by ESD if you don't pay attention to ESD protection. SGMICRO recommends that all integrated circuits be handled with appropriate precautions. Failure to observe proper handling and installation procedures can cause damage. ESD damage can range from subtle performance degradation to complete device failure. Precision integrated circuits may be more susceptible to damage because very small parametric changes could cause the device not to meet its published specifications.

PIN CONFIGURATIONS (Top View)

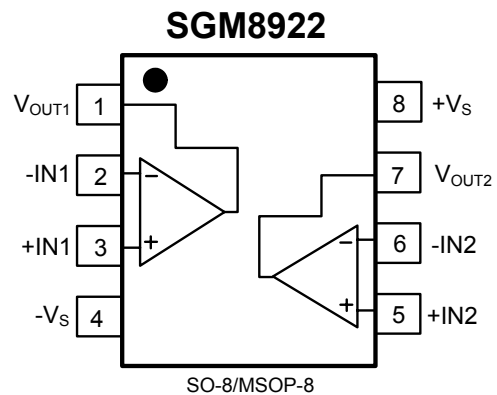

**ELECTRICAL CHARACTERISTICS:  $V_S = +5V$** (At  $T_A = +25^\circ\text{C}$ ,  $R_L = 600\Omega$  connected to  $V_S/2$ , unless otherwise noted)

PARAMETER	CONDITIONS	SGM8922				
		TYP	MIN/MAX OVER TEMPERATURE			
		+25°C	+25°C	-40°C $T_o$ +85°C	UNITS	MIN /MAX
<b>DYNAMIC PERFORMANCE</b>						
Gain-Bandwidth Product (GBP)	$R_L = 600\Omega$	12.7			MHz	TYP
Slew Rate	2Vpp Step, $A_V = 1$	6.8			V/ $\mu\text{s}$	TYP
Crosstalk	$f = 1\text{kHz}$	-120			dB	TYP
<b>NOISE/DISTORTION PERFORMANCE</b>						
Total Harmonic Distortion + Noise (THD)	$V_{OUT} = 2V_{pp}$ , $f = 1\text{kHz}$ , $A_V = 1$ , $R_L = 600\Omega$	0.003			%	TYP
Input Voltage Noise ( $e_n$ )	$f = 1\text{kHz}$	6			nV/ $\sqrt{\text{Hz}}$	TYP
Gain Margin	$R_L = 600\Omega$ , $C_L = 100\text{pF}$	18.5			dB	TYP
Phase Margin	$R_L = 600\Omega$ , $C_L = 100\text{pF}$	60			degree	TYP
<b>DC PERFORMANCE</b>						
Input Offset Voltage ( $V_{OS}$ )						
SGM8922			3	4.2	mV	MAX
SGM8922A			0.9	1.8	mV	MAX
Input Offset Voltage Drift		1.6			$\mu\text{V}/^\circ\text{C}$	TYP
Open-Loop Gain ( $A_{OL}$ )	$R_L = 600\Omega$ , $V_{OUT} = 0.15V$ to $4.85V$	109	91	85	dB	MIN
	$R_L = 10\text{k}\Omega$ , $V_{OUT} = 0.05V$ to $4.95V$	104	89	80	dB	MIN
<b>INPUT CHARACTERISTICS</b>						
Input Common Mode Voltage Range ( $V_{CM}$ )	$V_S = 5V$	-0.1 to 3.8			V	TYP
Common Mode Rejection Ratio (CMRR)	$V_S = 5.5V$ , $V_{CM} = -0.1V$ to $3.8V$	108	60	56	dB	MIN
<b>OUTPUT CHARACTERISTICS</b>						
Output Voltage Swing from Rails						
High Output Voltage Swing ( $V_{OH}$ )	$I_{OUT} = 100\text{mA}$	4.73	4.20	4.10	V	MIN
Low Output Voltage Swing ( $V_{OL}$ )	$I_{OUT} = -100\text{mA}$	0.24	0.45	0.56	V	MAX
Output Short Circuit Current			300		mA	MAX
<b>POWER SUPPLY</b>						
Operating Voltage Range			3	3	V	MIN
			5.5	5.5	V	MAX
Quiescent Current (per Amplifier)	$I_{OUT} = 0\text{mA}$	3	3.9		mA	MAX
Power Supply Rejection Ratio (PSRR)	$V_S = +2.5V$ to $+5.5V$ , $V_{CM} = (-V_S)+0.5V$	80	60	56	dB	MIN

Specifications subject to changes without notice.



TYPICAL PERFORMANCE CHARACTERISTICS

At  $T_A = +25^\circ\text{C}$ ,  $A_V = +1$ ,  $C_L = 100\text{pF}$  and  $R_L = 600\Omega$ , unless otherwise noted.

Small Signal Step Response

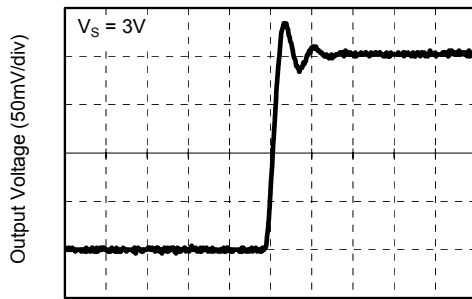

Time (100ns/div)

Small Signal Step Response

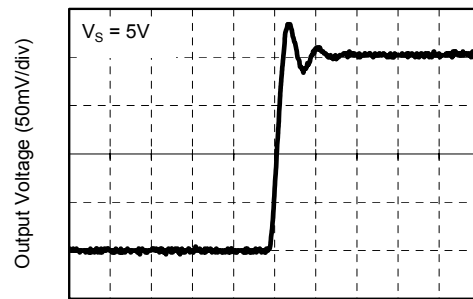

Time (100ns/div)

Large Signal Step Response

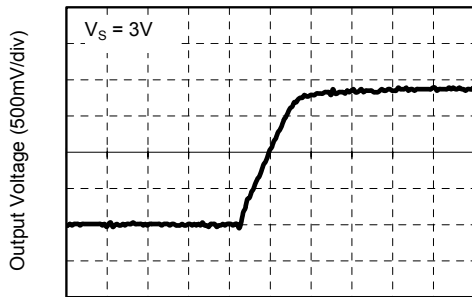

Time (500ns/div)

Large Signal Step Response

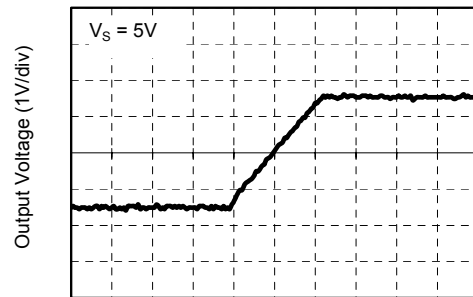

Time (500ns/div)

THD+N vs. Frequency

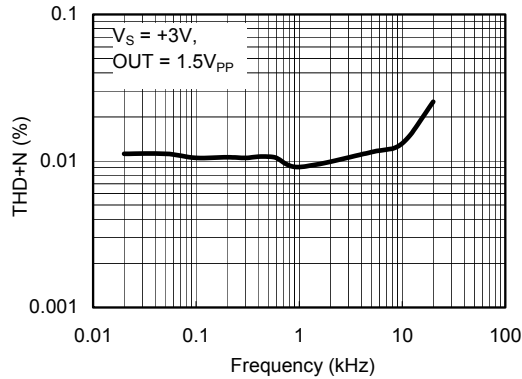

THD+N vs. Frequency

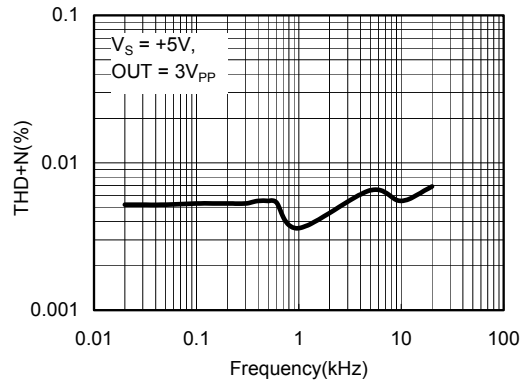

**TYPICAL PERFORMANCE CHARACTERISTICS**

At  $T_A = +25^\circ\text{C}$ ,  $A_V = +1$ ,  $C_L = 100\text{pF}$  and  $R_L = 600\Omega$ , unless otherwise noted.

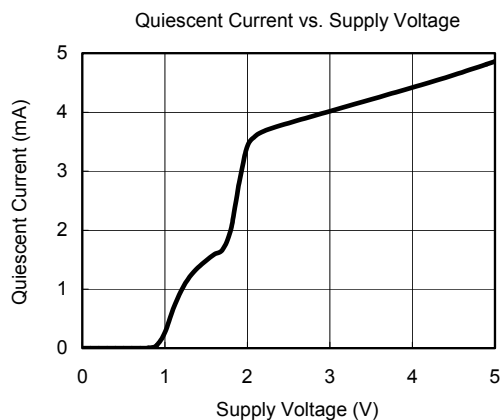
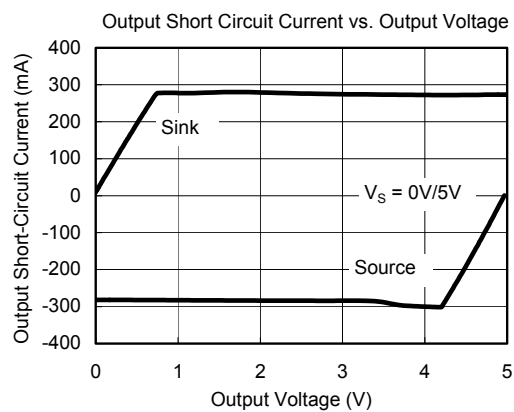

PACKAGE OUTLINE DIMENSIONS

SO-8

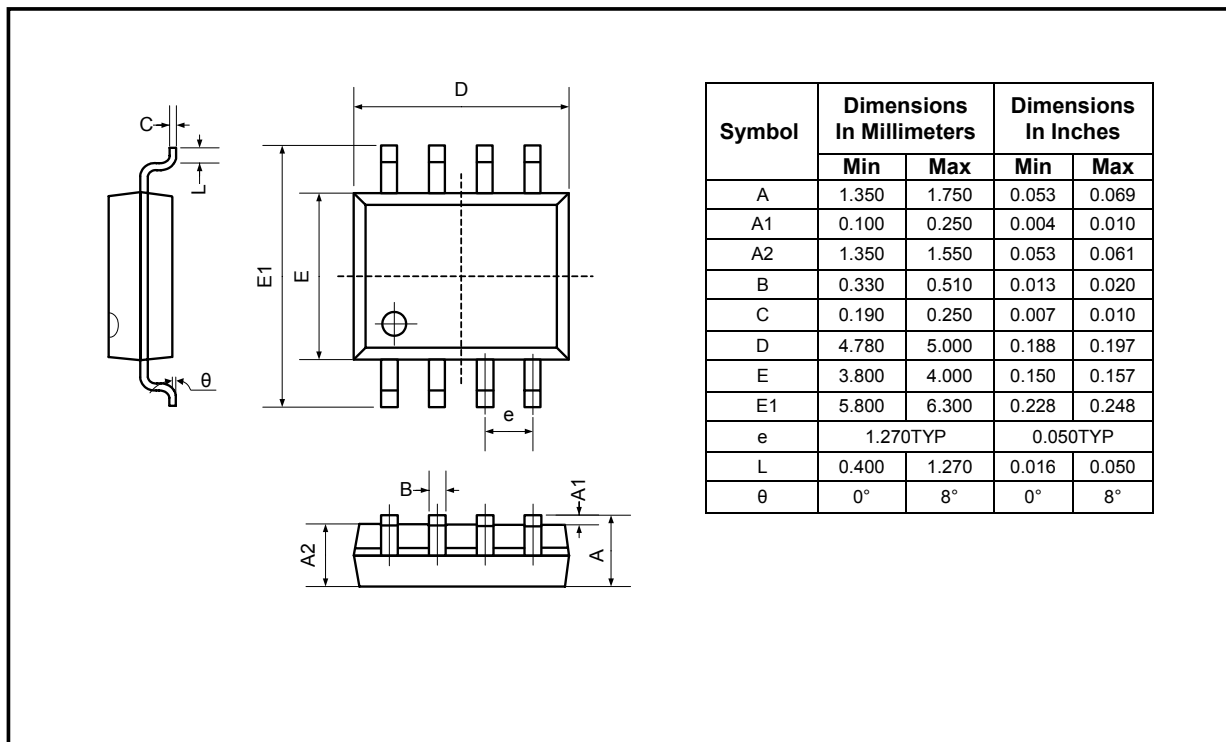

PACKAGE OUTLINE DIMENSIONS

MSOP-8

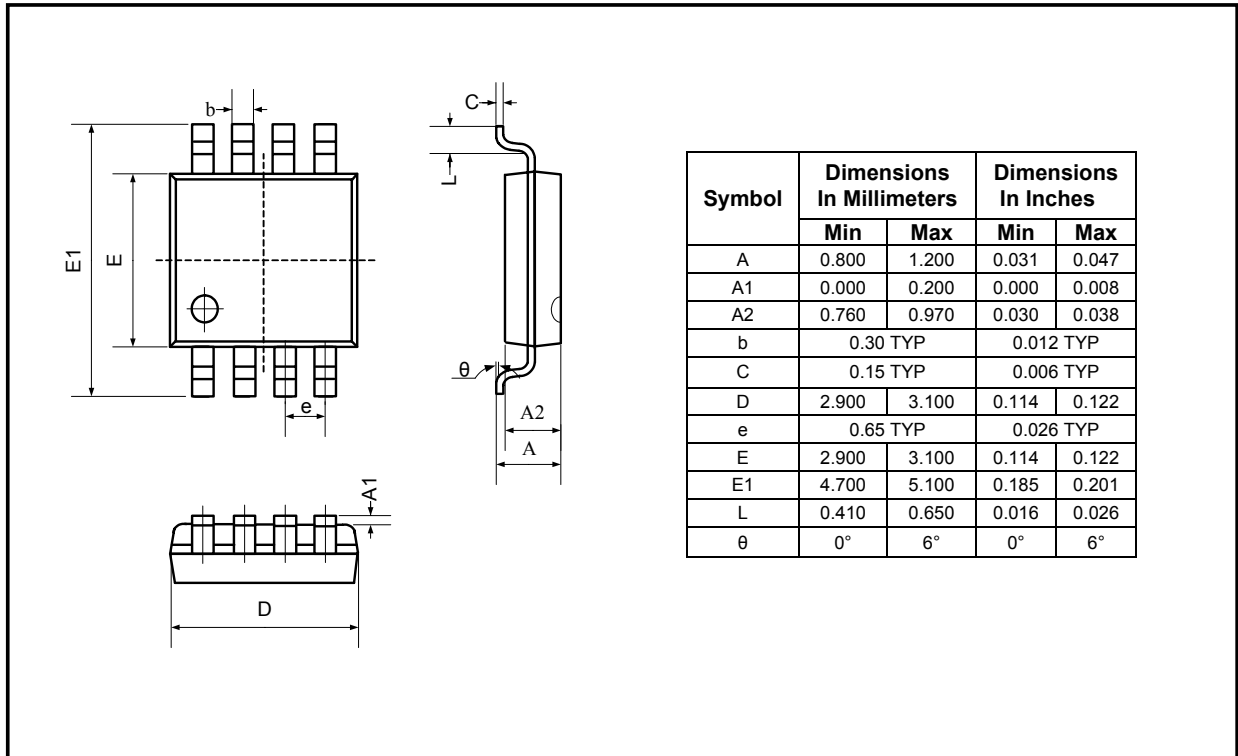

12/2008 REV. A. 1

SGMICRO is dedicated to provide high quality and high performance analog IC products to customers. All SGMICRO products meet the highest industry standards with strict and comprehensive test and quality control systems to achieve world-class consistency and reliability.

For information regarding SGMICRO Corporation and its products, see [www.sg-micro.com](http://www.sg-micro.com)



SG Micro Limited  
www.sg-micro.com