



273-MHz 6-Output Buffer for DDR400 DIMMS

Features

- Dual 1- to 3-output buffer/driver
- Supports up to 2 DDR DIMMs
- Outputs are individually enabled/disabled
- Low-skew outputs (< 100 ps)
- Supports 266-MHz, 333-MHz and 400-MHz DDR SDRAM
- SMBus Read and Write support
- Space-saving 28-pin SSOP package

Functional Description

The CY28359 is a 2.5V buffer designed to distribute high-speed clocks in PC applications. The part has 6 differential outputs. Designers can configure these outputs to support up to two DDR DIMMs. The CY28359 can be used in conjunction with the CY28326 or similar clock synthesizer for the VIA P4X600 chipset.

The CY28359 also includes an SMBus interface which can enable or disable each output clock. On power-up, all output clocks are enabled.

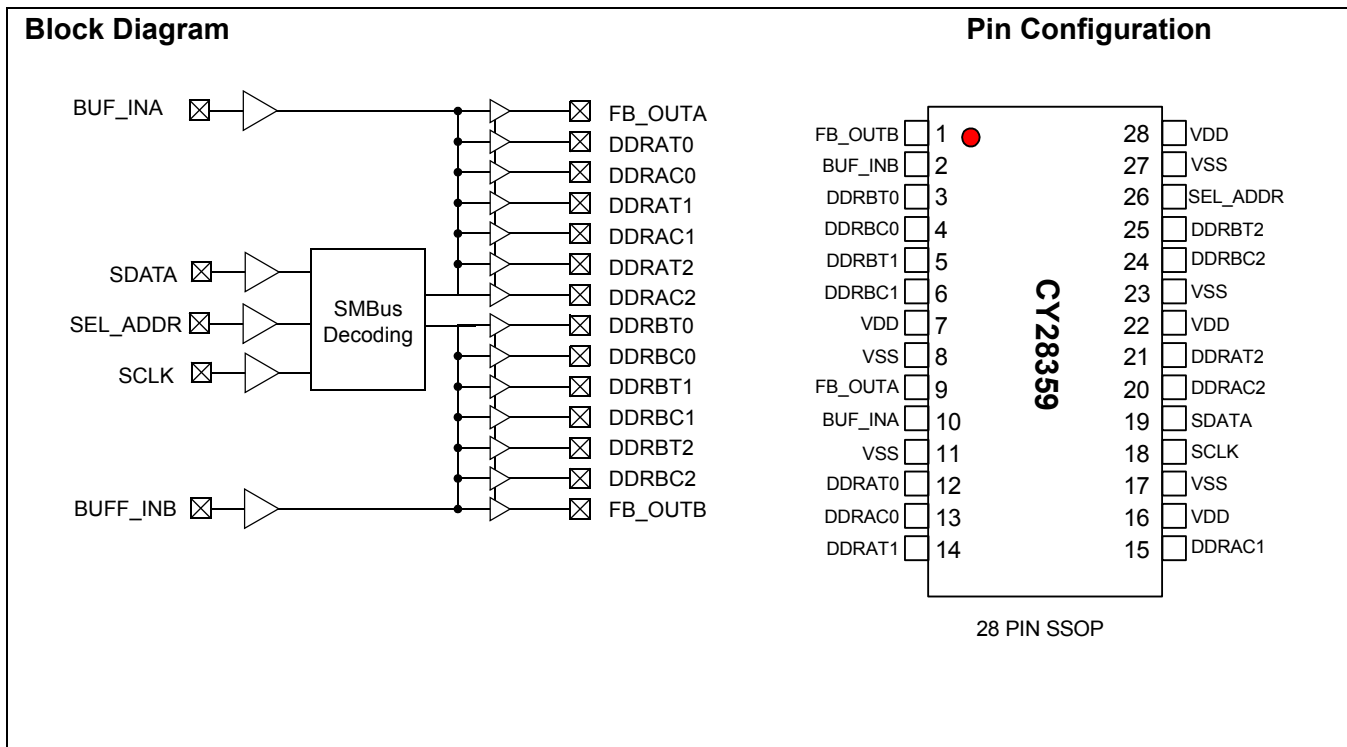

Pin Description

Pin	Name	PWR	I/O	Description
10 2	BUF_INA, BUF_INB	VDD2.5	I	Reference input from chipset. 2.5V input.
13,15,20 4,6,24	DDRA[0:2]C DDRB[0:2]C	VDD2.5	O	Clock outputs. These outputs provide complementary copies of BUF_INA & BUF_INB, respectively.
12,14,21 3,5,25	DDRA[0:2]T DDRB[0:2]T	VDD2.5	O	Clock outputs. These outputs provide copies of BUF_INA & BUF_INB, respectively.
9 1	FB_OUTA FB_OUTB	VDD2.5	O	Feedback clock for chipset
18	SCLK	VDD2.5	I	SMBus clock input. Has pull-up resistor
19	SDATA	VDD2.5	I/O	SMBus data input. Has pull-up resistor
26	SEL_ADDR		I	Address Select Pin. Has pull-down resistor
7,16,22,28	VDD2.5			2.5V voltage supply
8,11,17,23,27	VSS			Ground

Serial Data Interface

To enhance the flexibility and function of the clock synthesizer, a two-signal serial interface is provided. Through the Serial Data Interface, various device functions, such as individual clock output buffers, can be individually enabled or disabled. The registers associated with the Serial Data Interface initialize to their default setting upon power-up, and therefore use of this interface is optional. The interface can also be accessed during power down operation.

Data Protocol

The clock driver serial protocol accepts Byte Write, Byte Read, Block Write and Block Read operation from any external I²C

controller. For Block Write/Read operation, the bytes must be accessed in sequential order from lowest to highest byte (most significant bit first) with the ability to stop after any complete byte has been transferred. For Byte Write and Byte Read operations, the system controller can access individual indexed bytes. The offset of the indexed byte is encoded in the command code, as described in *Table 1*.

The Block Write and Block Read protocol is outlined in *Table 2* while *Table 3* outlines the corresponding Byte Write and Byte Read protocol. The slave receiver address is 11010010 (D2h) or 11011100 (DCh) depending on state of ADDRSEL.

Table 1. Command Code Definition

Bit	Description
7	0 = Block Read or Block Write operation 1 = Byte Read or Byte Write operation
(6:5)	01
(4:0)	Byte offset for Byte Read or Byte Write operation. For Block Read or Block Write operations, these bits should be '00000'

Table 2. Block Read and Block Write Protocol

Block Write Protocol		Block Read Protocol	
Bit	Description	Bit	Description
1	Start	1	Start
2:8	Slave address – 7 bits	2:8	Slave address – 7 bits
9	Write = 0	9	Write = 0
10	Acknowledge from slave	10	Acknowledge from slave
11:18	Command Code – 8 bits '00000000' stands for block operation	11:18	Command Code – 8 bits '00000000' stands for block operation
19	Acknowledge from slave	19	Acknowledge from slave
20:27	Byte Count – 8 bits	20	Repeat start
28	Acknowledge from slave	21:27	Slave address – 7 bits
29:36	Data byte 1 – 8 bits	28	Read = 1
37	Acknowledge from slave	29	Acknowledge from slave
38:45	Data byte 2 – 8 bits	30:37	Byte count from slave – 8 bits
46	Acknowledge from slave	38	Acknowledge from master
....	39:46	Data byte from slave – 8 bits
....	Data Byte (N-1) – 8 bits	47	Acknowledge from master
....	Acknowledge from slave	48:55	Data byte from slave – 8 bits
....	Data Byte N – 8 bits	56	Acknowledge from master
....	Acknowledge from slave	Data byte N from slave – 8 bits
....	Stop	Acknowledge from master
		Stop

Table 3. Byte Read and Byte Write Protocol

Byte Write Protocol		Byte Read Protocol	
Bit	Description	Bit	Description
1	Start	1	Start
2:8	Slave address – 7 bits	2:8	Slave address – 7 bits
9	Write = 0	9	Write = 0
10	Acknowledge from slave	10	Acknowledge from slave
11:18	Command Code – 8 bits '1XXxxxx' stands for byte operation, bit[6:5] for Device selection bits for multiple device selection, bits[4:0] of the command code represents the offset of the byte to be accessed	11:18	Command Code – 8 bits '1XXxxxx' stands for byte operation, bit[6:5] for Device selection bits for multiple device selection, bits[4:0] of the command code represents the offset of the byte to be accessed
19	Acknowledge from slave	19	Acknowledge from slave
20:27	Data byte from master – 8 bits	20	Repeat start
28	Acknowledge from slave	21:27	Slave address – 7 bits
29	Stop	28	Read = 1
		29	Acknowledge from slave
		30:37	Data byte from slave – 8 bits
		38	Acknowledge from master
		40	Stop

Serial Configuration Map

- The Serial bits will be read by the clock driver in the following order:
 - Byte 0 - Bits 7, 6, 5, 4, 3, 2, 1, 0
 - Byte 1 - Bits 7, 6, 5, 4, 3, 2, 1, 0
 - ...
 - Byte N - Bits 7, 6, 5, 4, 3, 2, 1, 0
- Reserved and unused bits should be programmed to "0".

SMBus Address for the CY28359 when SEL_ADDR=1:

A6	A5	A4	A3	A2	A1	A0	R/W
1	1	0	1	0	0	1	----

SMBus Address for the CY28359 when SEL_ADDR=0:

A6	A5	A4	A3	A2	A1	A0	R/W
1	1	0	1	1	1	0	----

Byte 22: Outputs Active/Inactive Register (1 = Active, 0 = Three-state), Default = Active

Bit	Pin #	Description	Default
Bit 7	--	Input Threshold Control00: Normal (1.25V) 01: 1.20V 10: 1.15V 11: 1.35V	0
Bit 6	--		0
Bit 5	9	FBOUTA 0 = Enable, 1 = Disable	0
Bit 4	1	FBOUTB 0 = Enable, 1 = Disable	0
Bit 3		Reserved, drive to 0	1
Bit 2	--	Reserved, drive to 0	1
Bit 1	24, 25	DDRBT2, DDRBC2	1
Bit 0	--	Reserved, drive to 0	1

Byte 23: Outputs Active/Inactive Register(1 = Active, 0 = Three-state), Default = Active

Bit	Pin #	Description	Default
Bit 7	5,6	DDRBT1, DDRBC1	1
Bit 6	3,4	DDRBT0, DDRBC0	1
Bit 5	21,20	DDRAT2, DDRAC2	1
Bit 4	--	Reserved, drive to 0	1
Bit 3	14,15	DDRAT1, DDRAC1	1
Bit 2	12,13	DDRAT0, DDRAC0	1
Bit 1	--	Reserved, drive to 0	1
Bit 0	--	Reserved, drive to 0	1

Absolute Maximum Conditions

Supply Voltage to Ground Potential -0.5 to +4.0V Static Discharge Voltage..... >2000V
 DC Input Voltage (except BUF_IN) -0.5V to $V_{DD}+0.5$ (per MIL-STD-883, Method 3015)
 Storage Temperature -65°C to +150°C

Operating Conditions

Parameter	Description	Min.	Typ.	Max.	Unit
$V_{DD2.5}$	Supply Voltage	2.375	–	2.625	V
T_A	Operating Temperature (Ambient Temperature)	–40	–	85	°C
C_{OUT}	Output Capacitance	–	6	–	pF
C_{IN}	Input Capacitance	–	5	–	pF

Electrical Characteristics Over the Operating Range

Parameter	Description	Test Conditions	Min.	Typ.	Max.	Unit
V_{IL}	Input LOW Voltage	For all pins except SMBus	–	–	0.8	V
V_{IH}	Input HIGH Voltage		2.0	–	–	V
I_{IL}	Input LOW Current	$V_{IN} = 0V$	–	–	5	μA
I_{IH}	Input HIGH Current	$V_{IN} = V_{DD}$	–	–	5	μA
I_{OH}	Output HIGH Current	$V_{DD} = 2.375V$ $V_{OUT} = 1V$	–18	–32	–	mA
I_{OL}	Output LOW Current	$V_{DD} = 2.375V$ $V_{OUT} = 1.2V$	26	35	–	mA
V_{OL}	Output LOW Voltage	$I_{OL} = 12\text{ mA}$, $V_{DD} = 2.375V$	–	–	0.6	V
V_{OH}	Output HIGH Voltage	$I_{OH} = -12\text{ mA}$, $V_{DD} = 2.375V$	1.7	–	–	V
I_{DD}	Supply Current	Unloaded outputs, 273 MHz	–	–	250	mA
I_{DD}	Supply Current	Loaded outputs, 273 MHz	–	–	300	mA
V_{OUT}	Output Voltage Swing	See Test Circuitry (Refer to Figure 1)	0.7	–	$V_{DD} + 0.6$	V
V_{OC}	Output Crossing Voltage		$(V_{DD}/2) - 0.2$	$V_{DD}/2$	$(V_{DD}/2) + 0.2$	V
IN_{DC}	Input Clock Duty Cycle		48		52	%

Switching Characteristics^[1]

Parameter	Name	Test Conditions	Min.	Typ.	Max.	Unit
F_O	Operating Frequency		66	–	273	MHz
T_{DC}	Duty Cycle = $t_2 \div t_1$	Measured at $V_{DD}/2$ for 2.5V outputs.	$IN_{DC} - 2\%$	–	$IN_{DC} + 2\%$	%
t_3	DDR Rising/Falling Edge Rate ^[2]	Measured between 20% to 80% of output (Refer to Figure 1)	1	–	3	V/ns
t_4	Output to Output Skew ^[2]	All outputs equally loaded	–	–	100	ps

Notes:

1. Parameter is guaranteed by design and characterization. Not 100% tested in production
2. All parameters specified with loaded outputs.

Switching Waveforms

Duty Cycle Timing

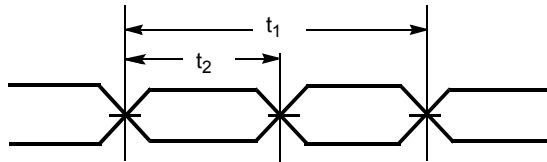

Output-Output Skew

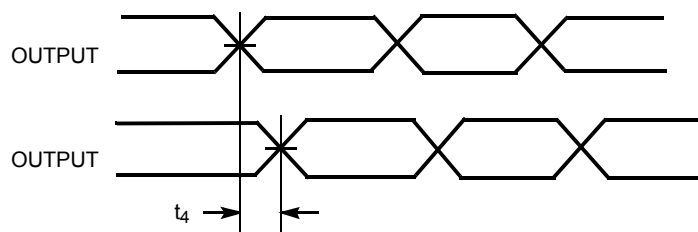

Figure 1 shows the differential clock directly terminated by a 120Ω resistor.

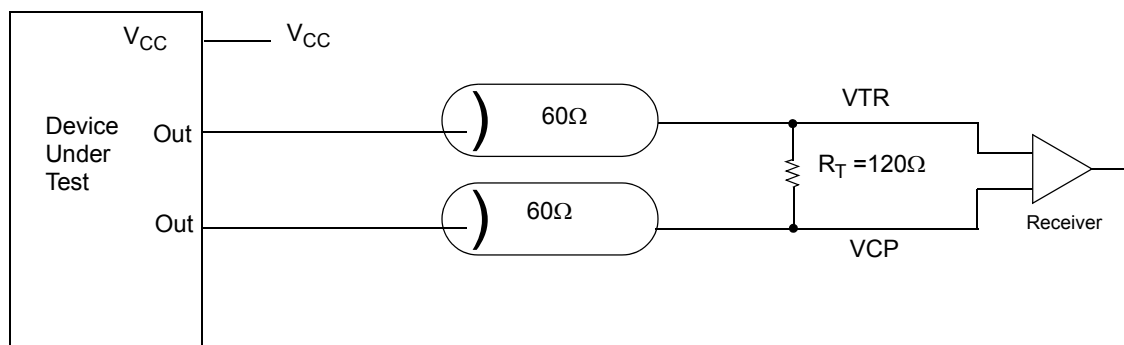

Figure 1. Differential Signal Using Direct Termination Resistor

Ordering Information

Ordering Code	Package Type	Operating Range
CY28359OC	28-pin SSOP	Commercial, 0°C to 70°C
CY28359OCT	28-pin SSOP (Tape & Reel)	Commercial, 0°C to 70°C
CY28359OI	28-pin SSOP	Industrial, -40°C to 85°C
CY28359OIT	28-pin SSOP (Tape & Reel)	Industrial, -40°C to 85°C

Document History Page

Document Title: CY28359 273-MHz 6-Output Buffer for DDR400 DIMMS
Document Number: 38-07636

Rev.	ECN No.	Issue Date	Orig. of Change	Description of Change
**	204380	See ECN	RGL	New Data Sheet