



2.5V or 3.3V 200-MHz 10-Output Zero Delay Buffer

Features

- Output frequency range: 50 MHz to 200 MHz
- Input frequency range: 50 MHz to 200 MHz
- 2.5V or 3.3V operation
- Ten clock outputs: drive up to 20 clock lines
- One Feedback output
- LVPECL reference clock input
- 150-ps max output-output skew
- Phase-locked loop (PLL) bypass mode
- Spread Aware™
- Output enable/disable
- Pin-compatible with MPC9658 and MPC958
- Industrial temperature range: -40°C to +85°C
- 32-Pin 1.0mm TQFP package

Description

The CY29658 is a low-voltage high-performance 200-MHz PLL-based zero delay buffer designed for high-speed clock distribution applications. The CY29658 features an LVPECL reference clock input and provides ten outputs plus one feedback output. VCO output divides by two or four per VCO_SEL setting (see *Function Table*). Each LVCMOS-compatible output can drive 50Ω series- or parallel-terminated transmission lines. For series-terminated transmission lines, each output can drive one or two traces giving the device an effective fanout of 1:20.

The PLL is ensured stable given that the VCO is configured to run between 200 MHz to 500 MHz. This allows a wide range of output frequencies from 50 MHz to 200 MHz. For normal operation, the external feedback input, FB_IN, is connected to the feedback output, FB_OUT. The internal VCO is running at multiples of the input reference clock set by the feedback divider (see *Frequency Table*).

When PLL_EN is LOW, PLL is bypassed and the reference clock directly feeds the output dividers. This mode is fully static and the minimum input clock frequency specification does not apply. When BYPASS# is set LOW, PLL and output dividers are bypassed resulting in a 1:11 LVPECL to LVCMOS high performance fanout buffer. For normal PLL operation, both PLL_EN and BYPASS# are set HIGH.

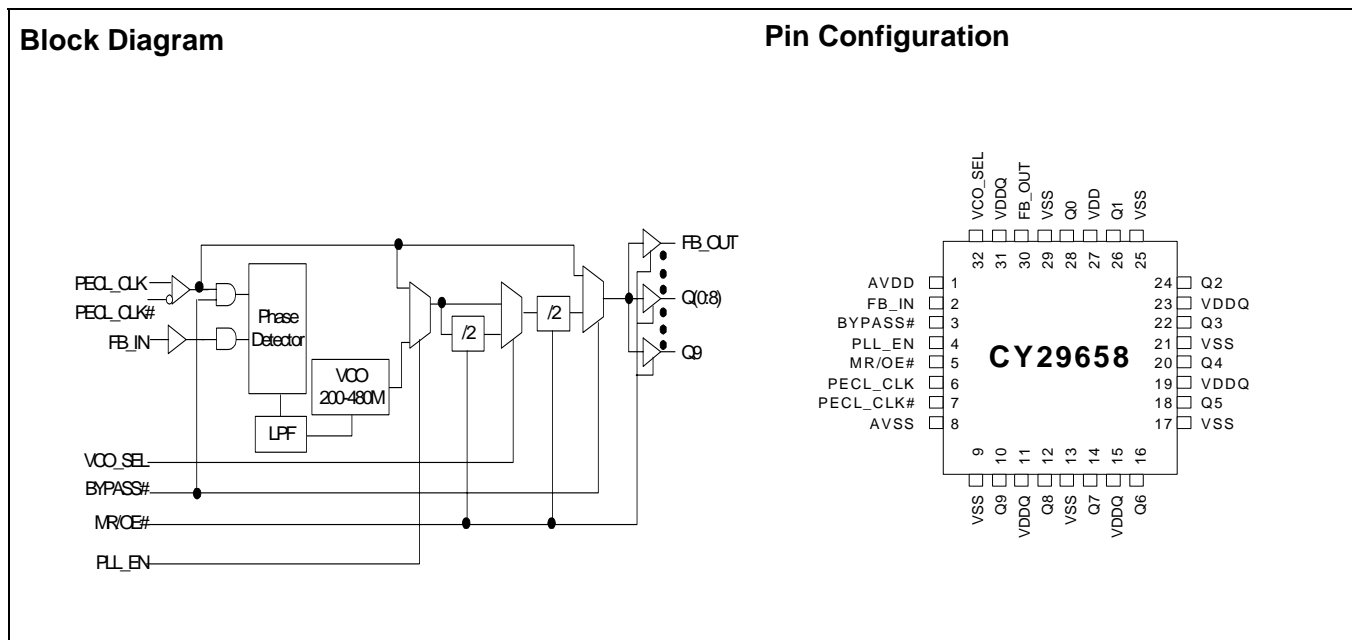

Downloaded from Elcodis.com electronic components distributor

Pin Description^[1]

Pin	Name	I/O	Type	Description
6	PECL_CLK	I, PU	LVPECL	LVPECL reference clock input.
7	PECL_CLK#	I, PU	LVPECL	LVPECL reference clock input. Pull-up to VDD/2.
10, 12, 14, 16, 18, 20, 22, 24, 26, 28	Q(9:0)	O	LVC MOS	Clock output.
30	FB_OUT	O	LVC MOS	Feedback clock output. Connect to FB_IN for normal operation.
2	FB_IN	I, PU	LVC MOS	Feedback clock input. Connect to FB_OUT for normal operation. This input should be at the same voltage rail as input reference clock. See <i>Table 1</i> .
5	MR/OE#	I, PD	LVC MOS	Output enable/disable input. See <i>Table 2</i> .
4	PLL_EN	I, PU	LVC MOS	PLL enable/disable input. See <i>Table 2</i> .
3	BYPASS#	I, PU	LVC MOS	PLL and output divider bypass select input. See <i>Table 2</i> .
32	VCO_SEL	I, PU	LVC MOS	VCO divider select input. See <i>Table 2</i> .
11, 15, 19, 23, 31	VDDQ	Supply	VDD	2.5V or 3.3V power supply for output clocks. ^[2,3]
1	AVDD	Supply	VDD	2.5V or 3.3V power supply for PLL. ^[2,3]
27	VDD	Supply	VDD	2.5V or 3.3V power supply for core and inputs. ^[2,3]
8	AVSS	Supply	Ground	Analog ground.
9, 13, 17, 21, 25, 29	VSS	Supply	Ground	Common ground.

Table 1. Frequency Table

Feedback Output Divider	VCO	Input Frequency Range (AVDD = 3.3V)	Input Frequency Range (AVDD = 2.5V)
÷2	Input Clock * 2	100 MHz to 200 MHz	100 MHz to 200 MHz
÷4	Input Clock * 4	50 MHz to 125 MHz	50 MHz to 100 MHz

Table 2. Function Table

Control	Default	0	1
VCO_SEL	1	VCO ÷ 1	VCO ÷ 2
PLL_EN	1	Bypass mode, PLL disabled. The input clock connects to the output dividers	PLL enabled. The VCO output connects to the output dividers
BYPASS#	1	Bypass mode with PLL and output dividers bypassed. The input clock connects to the outputs.	Selects the output dividers
MR/OE#	0	Outputs enabled	Outputs disabled (three-state), VCO running at its minimum frequency

Notes:

1. PU = Internal pull-up, PD = Internal pull-down.
2. A 0.1-μF bypass capacitor should be placed as close as possible to each positive power pin (<0.2"). If these bypass capacitors are not close to the pins their high-frequency filtering characteristics will be cancelled by the lead inductance of the traces.
3. AVDD and VDD pins must be connected to a power supply level that is at least equal or higher than that of VDDQ power supply pin.

Absolute Maximum Conditions

Parameter	Description	Condition	Min.	Max.	Unit
V _{DD}	DC Supply Voltage		-0.3	5.5	V
V _{DD}	DC Operating Voltage	Functional	2.375	3.465	V
V _{IN}	DC Input Voltage	Relative to V _{SS}	-0.3	V _{DD} + 0.3	V
V _{OUT}	DC Output Voltage	Relative to V _{SS}	-0.3	V _{DD} + 0.3	V
V _{TT}	Output termination Voltage			V _{DD} ÷ 2	V
LU	Latch Up Immunity	Functional	200		mA
R _{PS}	Power Supply Ripple	Ripple frequency < 100 kHz		150	mVp-p
T _S	Temperature, Storage	Non-functional	-65	+150	°C
T _A	Temperature, Operating Ambient	Functional	-40	+85	°C
T _J	Temperature, Junction	Functional		150	°C
∅ _{JC}	Dissipation, Junction to Case	Functional		42	°C/W
∅ _{JA}	Dissipation, Junction to Ambient	Functional		105	°C/W
ESD _H	ESD Protection (Human Body Model)		2000		V
FIT	Failure in Time	Manufacturing test		10	ppm

DC Electrical Specifications (V_{DD} = 2.5V ± 5%, T_A = -40°C to +85°C)

Parameter	Description	Condition	Min.	Typ.	Max.	Unit
V _{IL}	Input Voltage, Low	LVC MOS	-	-	0.7	V
V _{IH}	Input Voltage, High	LVC MOS	1.7	-	V _{DD} + 0.3	V
V _{PP}	Peak-Peak Input Voltage	LVPECL	250	-	1000	mV
V _{CMR}	Common Mode Range ^[4]	LVPECL	1.0	-	V _{DD} - 0.6	V
V _{OL}	Output Voltage, Low ^[5]	I _{OL} = 15 mA	-	-	0.6	V
V _{OH}	Output Voltage, High ^[5]	I _{OH} = -15 mA	1.8	-	-	V
I _{IL}	Input Current, Low ^[6]	V _{IL} = V _{SS}	-	-	-100	μA
I _{IH}	Input Current, High ^[6]	V _{IL} = V _{DD}	-	-	100	μA
I _{DDA}	PLL Supply Current	AVDD only	-	-	7	mA
I _{DDQ}	Quiescent Supply Current	All VDD pins except AVDD	-	-	4	mA
I _{DD}	Dynamic Supply Current	Outputs loaded @ 100 MHz	-	245	-	mA
C _{IN}	Input Pin Capacitance		-	4	-	pF
Z _{OUT}	Output Impedance		14	18	22	Ω

DC Electrical Specifications (V_{DD} = 3.3V ± 5%, T_A = -40°C to +85°C)

Parameter	Description	Condition	Min.	Typ.	Max.	Unit
V _{IL}	Input Voltage, Low	LVC MOS	-	-	0.8	V
V _{IH}	Input Voltage, High	LVC MOS	2.0	-	V _{DD} + 0.3	V
V _{PP}	Peak-Peak Input Voltage	LVPECL	250	-	1000	mV
V _{CMR}	Common Mode Range ^[4]	LVPECL	1.0	-	V _{DD} - 0.6	V
V _{OL}	Output Voltage, Low ^[5]	I _{OL} = 24 mA	-	-	0.55	V
		I _{OL} = 12 mA	-	-	0.30	
V _{OH}	Output Voltage, High ^[5]	I _{OH} = -24 mA	2.4	-	-	V

Notes:

- V_{CMR} (DC) is the crossing point of the differential input signal. Normal operation is obtained when the crossing point is within the V_{CMR} range and the input swing is within the V_{PP} (DC) specification.
- Driving one 50Ω parallel terminated transmission line to a termination voltage of V_{TT}. Alternatively, each output drives up to two 50 Ω series terminated transmission lines.
- Inputs have pull-up or pull-down resistors that affect the input current.

DC Electrical Specifications ($V_{DD} = 3.3V \pm 5\%$, $T_A = -40^\circ C$ to $+85^\circ C$) (continued)

Parameter	Description	Condition	Min.	Typ.	Max.	Unit
I_{IL}	Input Current, Low ^[6]	$V_{IL} = V_{SS}$	–	–	–100	μA
I_{IH}	Input Current, High ^[6]	$V_{IL} = V_{DD}$	–	–	100	μA
I_{DDA}	PLL Supply Current	AVDD only	–	–	7	mA
I_{DDQ}	Quiescent Supply Current	All VDD pins except AVDD	–	–	4	mA
I_{DD}	Dynamic Supply Current	Outputs loaded @ 100 MHz	–	330	–	mA
C_{IN}	Input Pin Capacitance		–	4	–	pF
Z_{OUT}	Output Impedance		12	15	18	Ω

AC Electrical Specifications ($V_{DD} = 2.5V \pm 5\%$, $T_A = -40^\circ C$ to $+85^\circ C$) ^[7]

Parameter	Description	Condition	Min.	Typ.	Max.	Unit
f_{VCO}	VCO Frequency		200	–	400	MHz
f_{in}	Input Frequency	± 2 Feedback	100	–	200	MHz
		± 4 Feedback	50	–	100	
		Bypass mode (BYPASS# = 0)	0	–	200	
f_{refDC}	Input Duty Cycle		40	–	60	%
V_{PP}	Peak-Peak Input Voltage	LVPECL	500	–	1000	mV
V_{CMR}	Common Mode Range ^[8]	LVPECL	1.2	–	$V_{DD} - 0.6$	V
f_{MAX}	Maximum Output Frequency	± 2 Output	100	–	200	MHz
		± 4 Output	50	–	100	
DC	Output Duty Cycle		45	–	55	%
t_r, t_f	Output Rise/Fall times	0.6V to 1.8V	0.1	–	1.0	ns
$t_{(\phi)}$	Propagation Delay (static phase offset)	PCLK to FB_IN, same VDD	–200	–	225	ps
t_{PD}	Propagation Delay (PLL and divider bypass)	PCLK to Q0 – Q9 BYPASS# = 0	4.1	5.5	6.9	ns
$t_{sk(O)}$	Output-to-Output Skew		–	–	150	ps
$t_{PLZ, HZ}$	Output Disable Time		–	–	6	ns
$t_{PZL, ZH}$	Output Enable Time		–	–	6	ns
BW	PLL Closed Loop Bandwidth (–3dB)	± 2 Feedback	–	1.9 – 2.2	–	MHz
		± 4 Feedback	–	1.8 – 2.1	–	
$t_{JIT(CC)}$	Cycle-to-Cycle Jitter		–	–	100	ps
$t_{JIT(PER)}$	Period Jitter		–	–	75	ps
$t_{JIT(\phi)}$	I/O Phase Jitter	I/O same VDD	–	–	150	ps
t_{LOCK}	Maximum PLL Lock Time		–	–	1	ms

AC Electrical Specifications ($V_{DD} = 3.3V \pm 5\%$, $T_A = -40^\circ C$ to $+85^\circ C$) ^[7]

Parameter	Description	Condition	Min.	Typ.	Max.	Unit
f_{VCO}	VCO Frequency		200	–	500	MHz
f_{in}	Input Frequency	± 2 Feedback	100	–	200	MHz
		± 4 Feedback	50	–	125	
		Bypass mode (BYPASS# = 0)	0	–	200	

Notes:

- AC characteristics apply for parallel output termination of 50Ω to V_{TT} . Parameters are guaranteed by characterization and are not 100% tested.
- V_{CMR} (AC) is the crosspoint of the differential input signal. Normal AC operation is obtained when the crosspoint is within the V_{CMR} range and the input swing lies within the V_{PP} (AC) specification. Violation of V_{CMR} or V_{PP} impacts static phase offset $t_{(\phi)}$.

AC Electrical Specifications ($V_{DD} = 3.3V \pm 5\%$, $T_A = -40^{\circ}C$ to $+85^{\circ}C$) (continued)^[7]

Parameter	Description	Condition	Min.	Typ.	Max.	Unit
f_{refDC}	Input Duty Cycle		40	–	60	%
V_{PP}	Peak-Peak Input Voltage	LVPECL	500	–	1000	mV
V_{CMR}	Common Mode Range ^[8]	LVPECL	1.2	–	$V_{DD} - 0.9$	V
f_{MAX}	Maximum Output Frequency	+2 Output	100	–	200	MHz
		+4 Output	50	–	125	
DC	Output Duty Cycle		45	–	55	%
t_r, t_f	Output Rise/Fall times	0.55V to 2.4V	0.1	–	1.0	ns
$t_{(\phi)}$	Propagation Delay (static phase offset)	PCLK to FB_IN, same VDD	–200	–	225	ps
t_{PD}	Propagation Delay (PLL and divider bypass)	PCLK to Q0 – Q9 BYPASS# = 0	3.6	4.8	6.0	ns
$t_{sk(O)}$	Output-to-Output Skew		–	–	150	ps
$t_{PLZ, HZ}$	Output Disable Time		–	–	6	ns
$t_{PZL, ZH}$	Output Enable Time		–	–	6	ns
BW	PLL Closed Loop Bandwidth (–3dB)	+2 Feedback	–	1.9 – 2.2	–	MHz
		+4 Feedback	–	1.8 – 2.1	–	
$t_{JIT(CC)}$	Cycle-to-Cycle Jitter		–	–	100	ps
$t_{JIT(PER)}$	Period Jitter		–	–	75	ps
$t_{JIT(\phi)}$	I/O Phase Jitter	I/O same VDD	–	–	150	ps
t_{LOCK}	Maximum PLL Lock Time		–	–	1	ms

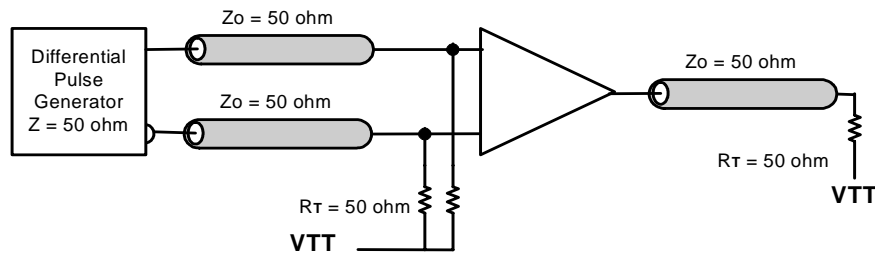
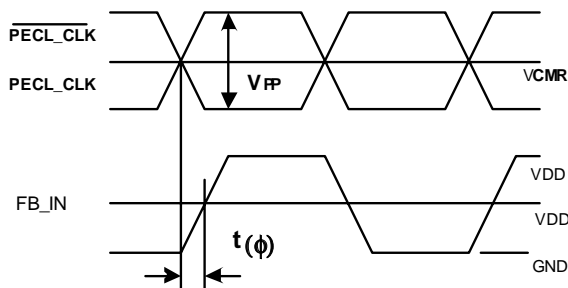
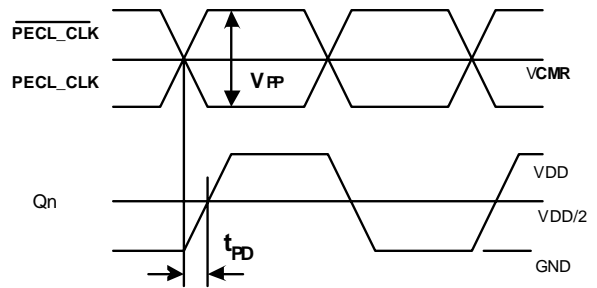
Figure 1. AC Test Reference for $V_{DD} = 3.3V / 2.5V$

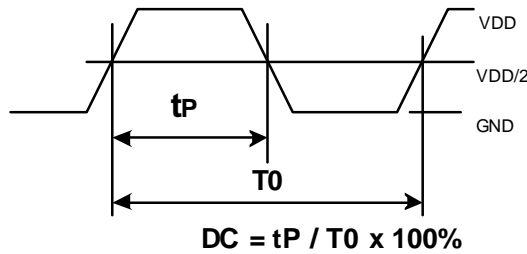
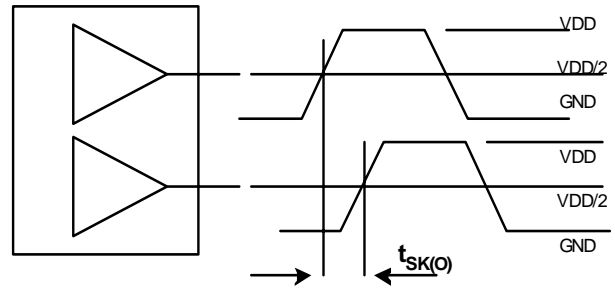
Figure 2. Propagation Delay $t_{(\phi)}$, Static Phase Offset

Figure 3. Propagation Delay t_{PD} , PLL Bypass

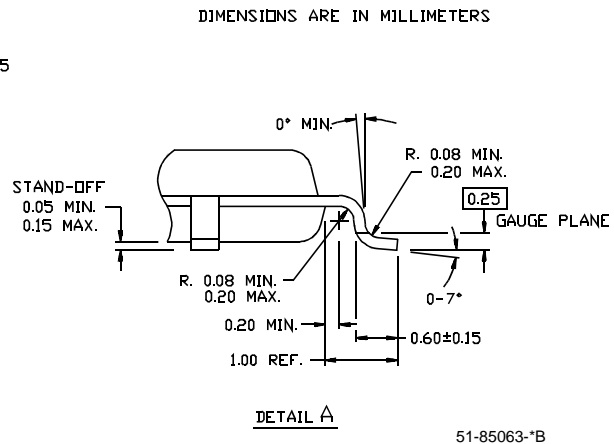
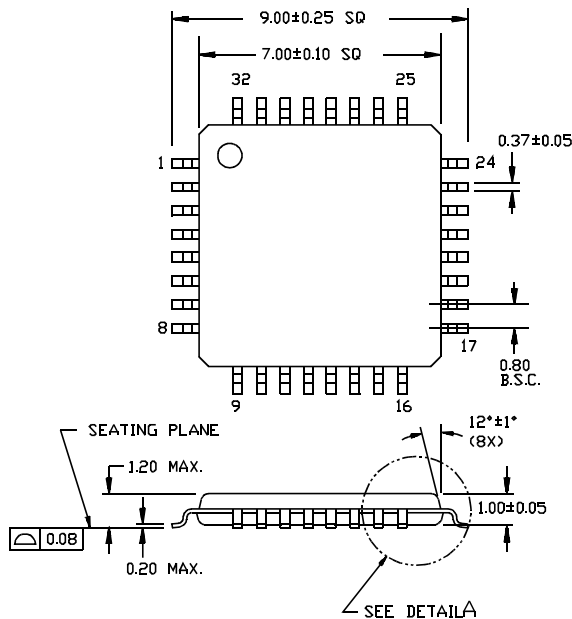
Figure 4. Output Duty Cycle (DC)

Figure 5. Output-to-Output Skew $t_{sk(O)}$
Ordering Information

Part Number	Package Type	Product Flow
CY29658AI	32-pin TQFP	Industrial, -40°C to +85°C
CY29658AIT	32-pin TQFP – Tape and Reel	Industrial, -40°C to 85°C

Package Drawing and Dimension
32-lead Thin Plastic Quad Flatpack 7 x 7 x 1.0mm A32

Spread Aware is a trademark of Cypress Semiconductor Corporation. All product and company names mentioned in this document are the trademarks of their respective holders.

Document History Page

Document Title:CY29658 2.5V or 3.3V 200-MHz 10-Output Zero Delay Buffer Document Number: 38-07478				
Rev.	ECN No.	Issue Date	Orig. of Change	Description of Change
**	126716	05/19/03	RGL	New Data Sheet